



M999888A

ITEM NUMBER: 999888

SERIAL NUMBER: _____

OWNER'S MANUAL

Instructions for Assembly, Testing, Operation, Servicing, and Storage

Utility Sprayer: For outdoor use with agricultural pesticides and other liquids**

⚠WARNING

READ and UNDERSTAND the Owner's Manual completely before using this sprayer. Assemble, test, and use only in accordance with the Owner's Manual instructions.

READ and FOLLOW chemical label instructions. Pesticides are hazardous chemicals.

KNOW emergency procedures BEFORE handling chemicals. Sprayer leaks, bodily chemical contact, poisoning, and spills require immediate response.

AVOID inhaling, ingesting, or coming into contact with any chemicals.

WEAR personal protective gear when filling, using, cleaning, and servicing the sprayer.

KEEP sprayer and spray materials away from children and pets

EXERCISE CAUTION when moving a filled sprayer to avoid loss of control or sprayer overturning.

DO NOT TURN ON POWER to sprayer until ready to spray in order to avoid unintentional spray release.

ALWAYS keep a fire extinguisher rated "ABC" nearby.

Improper use of the sprayer or handling of chemicals could result in serious injury or illness to the operator or nearby persons/animals or could cause damage to the environment.

**This sprayer is recommended for use in spraying non-flammable liquids such as pesticides and water for plants/trees. The sprayer will be damaged and warranty voided if used to apply bleach, chlorine, ice control chemicals, or any petroleum based product (gasoline, diesel, kerosene, oil). The sprayer should not be used to transfer any product intended for human consumption. WE RECOMMEND THAT THE SPRAYER NOT BE USED FOR OTHER PURPOSES ONCE IT HAS BEEN USED FOR SPRAYING PESTICIDES. Any chemical will leave some residual in the tank liner or sprayer components, even after the sprayer has been properly cleaned. These residual chemicals can have unexpected effects on future uses. For example, spraying water or other liquids that are contaminated with residual pesticide may result in unforeseen hazards to plant or animal life. This sprayer should not be used by people with reduced physical, sensory or mental capabilities or lack of experience and knowledge.

Any Questions, Comments, Problems, or Parts Orders

Call NorthStar Product Support 1-800-270-0810

Hazard Signal Word Definitions





	<p>This is the safety alert symbol. It is used to alert you to potential personal injury hazards. Obey all safety messages that follow this symbol to avoid possible injury or death.</p>
	<p>DANGER (red) indicates an imminently hazardous situation which, if not avoided, will result in death or serious injury.</p>
	<p>WARNING (orange) indicates a potentially hazardous situation which, if not avoided, could result in death or serious injury.</p>
	<p>CAUTION (yellow) indicates a potentially hazardous situation which, if not avoided, may result in minor or moderate injury.</p>
	<p>CAUTION (yellow) used without the safety alert symbol indicates a potentially hazardous situation which, if not avoided, may result in property damage.</p>

fig01453

Table of Contents

Intended Use	4
Summary of Important Safety Information.....	5
Warning Label Location	7
Unpacking	8
Unpacking the Manual Bag	9
Assembly	10
Machine Components	14
Operation – Important Safety Information.....	15
Operation – Preparing the Sprayer for Each Use	19
Operation – Using the Sprayer.....	20
Storage	27
Troubleshooting	28
Specifications	29
Exploded View & Parts List – Rev A	30
Pump Exploded View	32
Limited Warranty	33

Intended Use

The sprayer is intended for use in spraying agricultural pesticides.

SPRAYING PESTICIDES:

Pesticides are hazardous chemicals that must be handled with caution as directed throughout this manual and on the pesticide label. Pesticides are regulated by the United States Environmental Protection Agency (EPA) and defined as:

Any substance or mixture of substances intended for preventing, destroying, repelling, or mitigating any pest. Though often misunderstood to refer only to insecticides, the term pesticide is a comprehensive term that applies to insecticides, herbicides, fungicides, and various other substances used to control pests.

SPRAYING OTHER LIQUIDS:

In addition to spraying pesticides, this sprayer may be used for watering plants and trees. **WE RECOMMEND THAT THE SPRAYER NOT BE USED FOR OTHER PURPOSES ONCE IT HAS ALREADY BEEN USED FOR SPRAYING PESTICIDES.** Any chemical will leave some residual in the tank liner or sprayer components, even after the sprayer has been properly cleaned. These residual chemicals can have unexpected effects on future uses. For example, spraying water or other liquids that are contaminated with residual pesticide may result in unforeseen hazards to plant or animal life.

NOTE: The sprayer will be damaged and warranty voided if used to apply bleach, chlorine, ice control chemicals, or any petroleum based product (gasoline, diesel, kerosene, oil).

Contact NorthStar Product Support at 1-800-270-0810 for any questions about the appropriate use of the sprayer and/or optional accessories.

Summary of Important Safety Information

LISTED BELOW is a summary of safety information of particular importance. See individual sections of this owner's manual for more details.

WARNING

Read and understand **this owner's manual** completely before using the sprayer. Read each **chemical label's instructions** before handling the chemical.

Improper use of the sprayer or handling of chemicals could result in serious injury or illness for the operator or nearby persons/animals, or cause damage to the environment.

----- DURING ASSEMBLY -----

- **EXERCISE CAUTION when attaching switch to battery terminals.** Follow the steps listed in the Assembly section of this manual *in exact sequence* when connecting the sprayer's switch to the battery terminals. *Caution must be exercised to avoid contact with battery acid and to prevent sparking.*
- **CHECK and TEST completed assembly** as directed in this manual. Serious injury could result from chemical leaks if sprayer is improperly assembled.
- **DO NOT MODIFY sprayer design.**

----- DURING OPERATION -----

General Chemical Safety

- **READ and FOLLOW** each chemical label's instructions and warnings.
- **AVOID inhaling, ingesting, or coming into contact with any chemicals.**
- **KNOW applicable licensing and regulatory requirements** for the chemical you plan to use.
- **KNOW emergency procedures before handling chemicals.** Carefully review "Chemical Accident Procedures" listed below and later in this manual. Also see First Aid instructions on the chemical label.
- **WEAR protective clothing, eye protection, and chemical resistant gloves** when filling, using and cleaning the sprayer. Wear additional protective gear, such as facemask or apron, as recommended on the chemical label.
- **EXERCISE EXTRA CAUTION around children and pets.** Always keep sprayer and spray materials away from them.
- **DO NOT MIX OR POUR chemicals in an enclosed, unventilated area**
- **DO NOT USE flammable chemicals** in the sprayer.
- **STORE chemicals in a correctly labeled container and in a secure location.**
- **MONITOR the health of operators frequently exposed to chemicals**, as recommended by the chemical label or local/federal regulations.

Chemical Application Safety

Before Spraying

- **INSPECT and PREPARE sprayer before each use** as directed in this manual.
- **DO NOT TURN ON POWER to sprayer until ready to spray** in order to avoid unintentional spray release.
- **DO NOT SPRAY when wind speed exceeds 4 MPH** in order to minimize spray drift.
- **CLEAR work area of people/ pets and POST warning notices** to restrict access for the period recommended on chemical label.
- **KEEP sprayer and spray away from children/pets.**
- **DO NOT ALLOW anyone younger than 16 to operate sprayer.**

During Spraying

- **DO NOT OVERAPPLY chemical.** Apply at rate recommended by chemical manufacturer. Excess chemical can be dangerous to humans/animals, damage desirable plants, and contaminate soil and water sources.
- **DO NOT EAT, DRINK, SMOKE, RUB YOUR EYES, or TOUCH YOUR BARE SKIN while handling chemicals and spraying.**
- **NEVER POINT THE SPRAY GUN at people or animals.**

Summary of Important Safety Information (continued)

- **EXERCISE EXTRA CAUTION** when spraying near areas accessible to children and pets.
- **CLEAN up spills immediately** per instructions on the chemical label.
- **TURN OFF power to sprayer, and RELIEVE system pressure** before leaving sprayer unattended.
- **SEE Troubleshooting section of this manual before attempting any repairs.** Wear personal protective equipment and follow safety instructions.

After Spraying

- **CLEAN sprayer immediately after use** according to the directions provided in this manual.
- **DECONTAMINATE yourself after you are done spraying** and have cleaned the sprayer. Wash all exposed areas of the body with soap and water and remove and launder clothing.
- **DISPOSE OF or STORE remaining chemicals in secure storage with correctly marked container.**

Chemical accident procedures

Immediate response is necessary in the event of sprayer leaks, bodily chemical contact, poisoning, or spills.

Sprayer leak	If the sprayer develops a leak, <i>immediately stop spraying.</i> Turn off power to the sprayer and follow directions below, as applicable.
Bodily chemical contact	<p>Personal contamination can occur when chemicals splash, spill, or spray directly onto a person.</p> <ol style="list-style-type: none"> 1. Immediately follow First Aid instructions on <u>chemical label</u>. <u>General procedures can include:</u> <ol style="list-style-type: none"> a) Eyes – immediately flush with water. b) Skin – wash all contaminated skin surfaces with soap and water. c) Clothing – remove contaminated clothing. Dispose of heavily contaminated clothing per chemical label instructions. 2. Seek medical advice if instructed on the label or the victim experiences symptoms of harmful effects. Bring the chemical label for reference.
Poisoning by ingestion or inhalation	<p>In case of poisoning from ingestion or inhalation: <i>If the victim has collapsed or is not breathing, call 911.</i> Otherwise:</p> <ol style="list-style-type: none"> 1. If you are the victim, immediately seek assistance from nearby personnel because you may become incapacitated. 2. Immediately follow first aid instructions on <u>chemical label</u>. 3. Call a poison control center for further advice. In the U.S., call 1-800-222-1222. Have the chemical label available for reference.
Chemical spills	<p>Chemical spills must be quickly contained and properly cleaned up. Refer to the chemical label for any specific clean-up instructions. <u>General procedures include:</u></p> <ol style="list-style-type: none"> 1. Controlling the spill by stopping the source of the spill. 2. Containing the spill so that it does not spread and get into water sources. 3. Cleaning up the spill immediately. 4. Seeking additional advice from: <ul style="list-style-type: none"> - <u>Chemical manufacturer.</u> See chemical label for contact information.

Warning Label Location

⚠ WARNING

READ and UNDERSTAND the Owner's Manual completely before using this sprayer. Assemble, test, and use only in accordance with the Owner's Manual instructions.

READ and FOLLOW chemical label instructions. Pesticides are hazardous chemicals which must be handled carefully.

KNOW emergency procedures BEFORE handling chemicals. Sprayer leaks, bodily chemical contact, poisoning, and spills are all situations which require immediate response.

AVOID Inhaling, Ingesting, or coming into contact with any chemicals.

EXERCISE CAUTION in vehicle handling. Vehicle will be less stable and handle very differently with filled sprayer attached.

DO NOT TURN ON power to sprayer until ready to spray in order to avoid inadvertent spray release. DO NOT LIFT sprayer unless tank is empty.

Improper use of the sprayer or handling of chemicals could result in serious injury or illness to the operator or nearby persons/animals, or could cause damage to the environment.

Replace this label if damaged or destroyed. Consult Owner's Manual for ordering instructions.

PN 777499

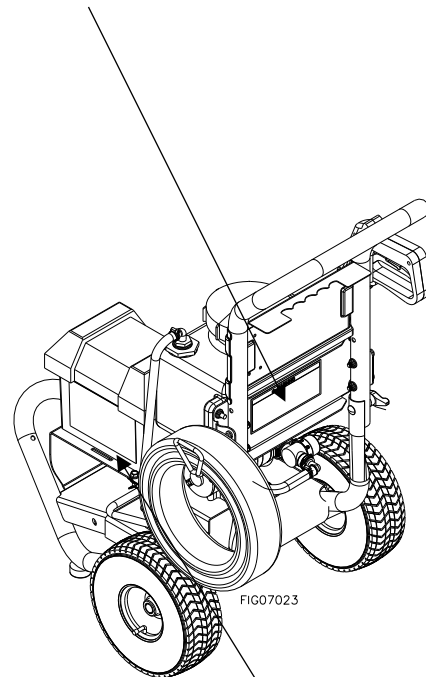
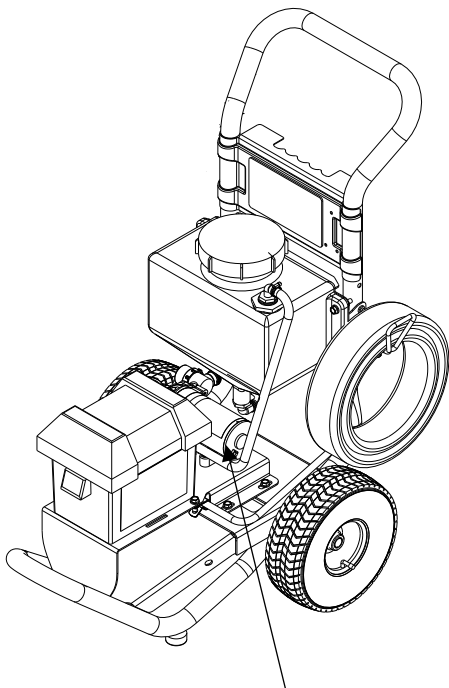

⚠ WARNING

DO NOT PUMP FLAMMABLE FLUIDS. DO NOT USE PUMP IN AN EXPLOSIVE ENVIRONMENT. READ AND UNDERSTAND THE OWNER'S MANUAL COMPLETELY BEFORE USING. RELIEVE SYSTEM PRESSURE BEFORE PERFORMING MAINTENANCE.

⚠ WARNING

BATTERY HAZARDS

BATTERIES: 1) contain caustic acid, 2) emit explosive gases, 3) can cause electric shock

- ALWAYS use eye protection. Caustic acid and explosive gases can cause blindness or severe burns.
- NO smoking, sparks, or flames.
- NEVER touch both battery terminals at the same time with your hand or any non insulated tools.
- FLUSH immediately with water if battery acid contacts eyes, skin or clothing.
- CONNECT cables in correct sequence: FIRST RED to POSITIVE terminal, then BLACK to NEGATIVE terminal. When disconnecting, DISCONNECT BLACK cable first, then RED.
- NEVER charge a visibly damaged or frozen battery. ALWAYS read and follow charger instructions.

782397

Part#	Description
802397	Decal, chemical warning
797405	Decal, pump
782397	Decal, Battery warning

Always make sure safety labels are in place and in good condition. If a safety label is missing or not legible, order new labels or unsafe operation could result.

To order replacement safety labels, call NorthStar Product Support at 1-800-270-0810.

Unpacking

Closely inspect all contents in the shipping carton.

- If you have missing or damaged components, please contact NorthStar Product Support at 1-800-270-0810.

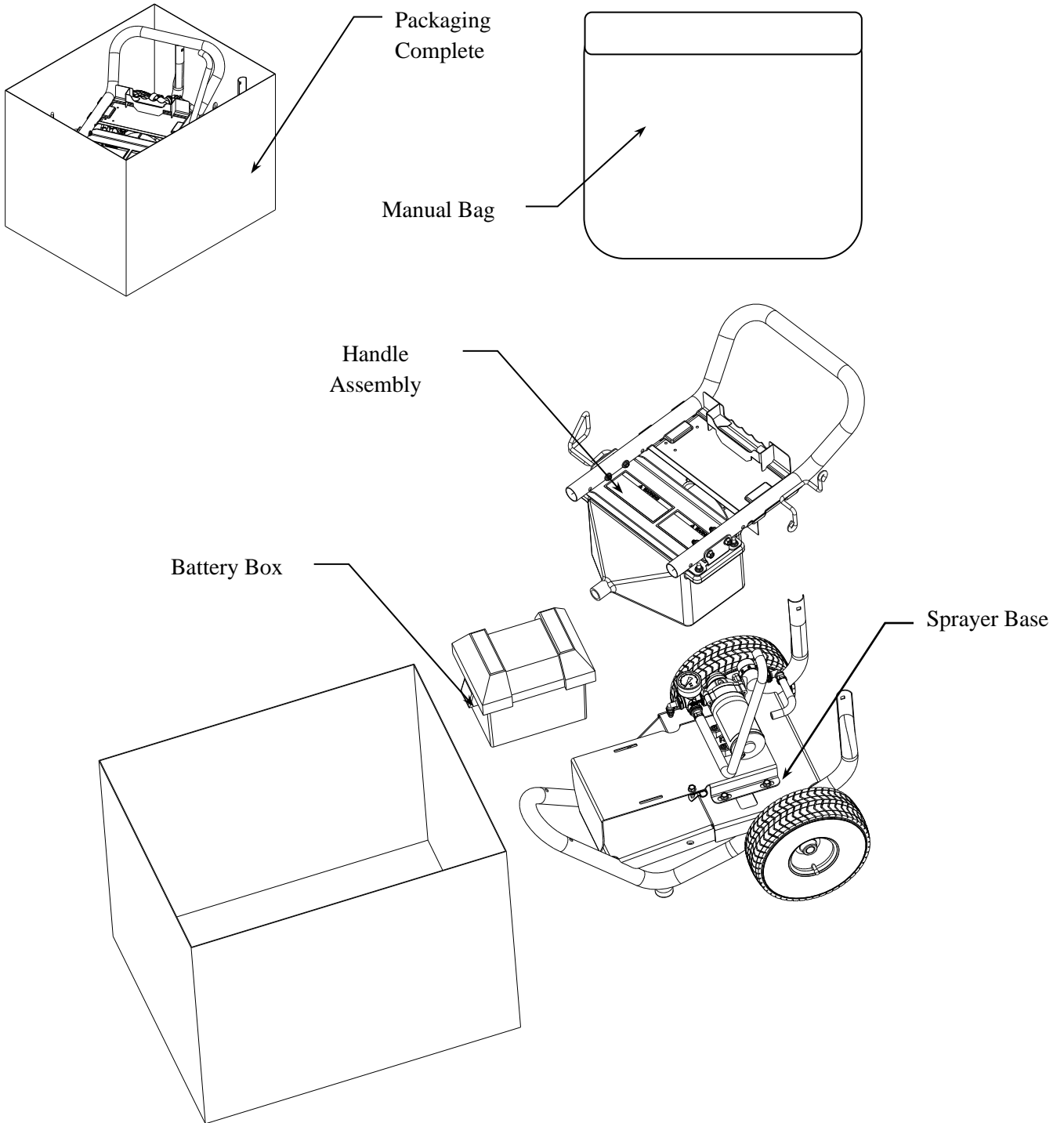

Unpacking the Manual Bag

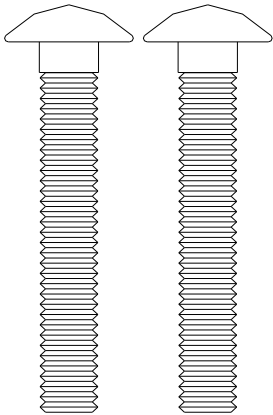

PART #82233
5/16-18 X 2" CARRIAGE BOLT
QTY: 2

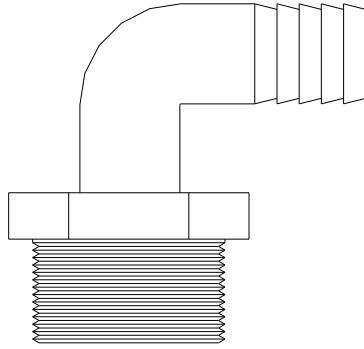

PART #779269
3/4" NPT X 1/2" HB
ELBOW
QTY: 1

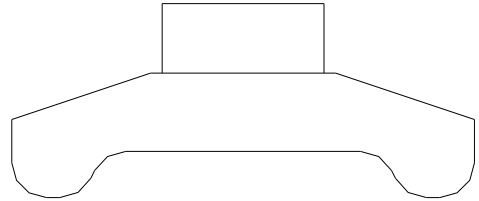

PART #38578
T-HANDLE
KNOB
QTY: 2

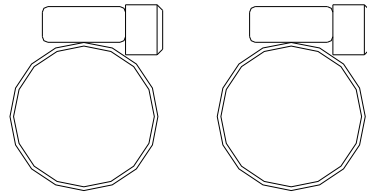
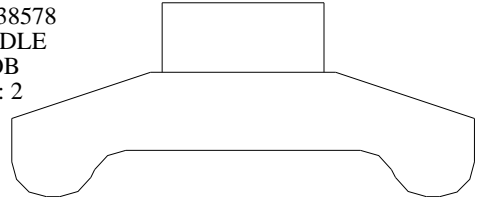

PART #777119 - 1/2" HOSE CLAMP - QTY: 2

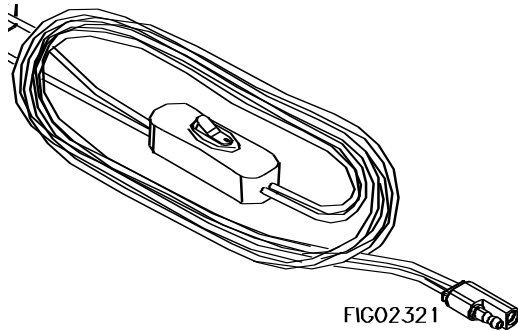
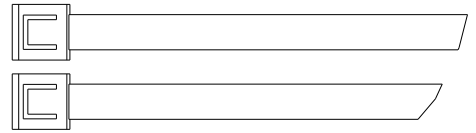
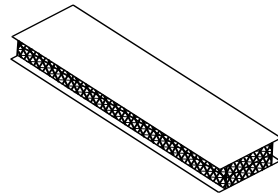

FIG02321

Switch Wire harness
Qty: 1
Part #802378



PART #82155 - ZIP TIES - QTY: 2



Hook and Loop Tape
Qty: 1
Part #35363

Assembly

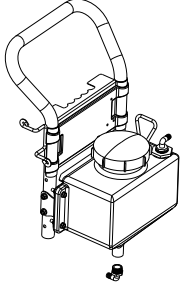
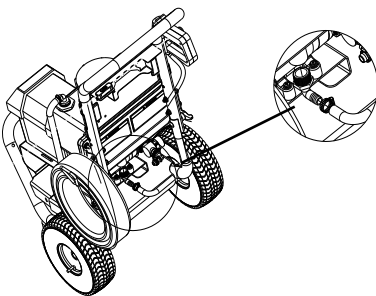
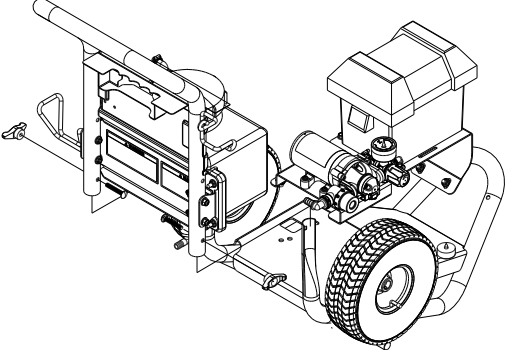
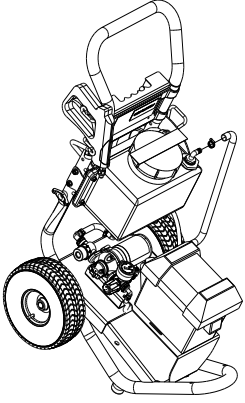
1. Preparatory safety	<p>Preparatory safety steps:</p> <ul style="list-style-type: none"> • ALWAYS use eye protection • NEVER smoke or work near sparks or other sources of ignition. • NEVER touch both battery terminals at the same time or with any non-insulated tools. • If battery acid contacts skin or clothing, flush immediately with water and neutralize with baking soda.
2. Install fitting to tank	<p>Remove shipping plug from bottom of tank and install elbow fitting 779269. Orient so the hose barb will be facing away from the pump.</p> <div style="text-align: right; margin-top: 10px;">  </div>
3. Install handle and connect inlet hose	<p>Install Handle Assembly to Sprayer base using (2) Carriage bolts 5/16-18 X 2" and (2) T-Knobs which are supplied in the manual bag. Connect hose from the pump inlet. Secure with (1) hose clamp (777119) which is supplied in the manual bag.</p> <div style="display: flex; justify-content: space-around; align-items: center;"> <div style="text-align: center;">  </div> <div style="text-align: center;">  </div> </div>
4. Connect bypass hose	<p>Connect hose to hose barb on the top of the tank and secure with (1) hose clamp (777119) which is supplied in the manual bag.</p> <div style="text-align: right; margin-top: 10px;">  </div>

Assembly

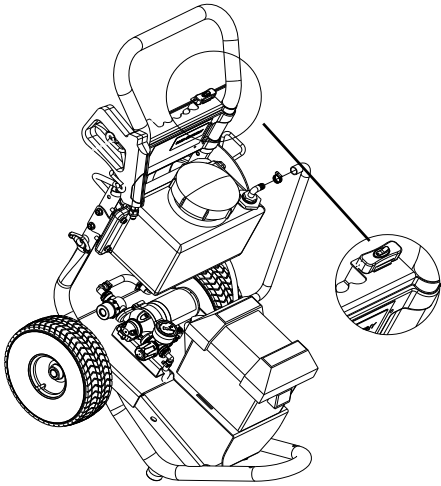
<p>5. Attach switch to sprayer</p>	<p>Place hook and loop tape to billboard of sprayer. Press switch onto the hook and loop tape and secure. Route the wire harness to connect to the battery. Use zip ties to secure wire to the handle.</p> <p><u>DO NOT connect to battery at this time.</u></p>	 <p>The diagram shows a side view of a sprayer with a tank, pump, and handle. A callout circle highlights the area where the switch is attached to the handle. The switch is connected to a wire harness that runs towards the battery compartment.</p>
<p>6. Connect switch to pump power cord</p>	<p>Connect the switch cord to the pump power cord:</p> <p>Note: Make sure the power switch is in the OFF position on the remote switch.</p>	
<p>7. Install battery</p>	<p>Install battery into box and attach battery box to frame with supplied strap.</p> <p>Leave lid off until wiring connections are made.</p> <ul style="list-style-type: none"> - Note: Battery box holds a 35AH U1 size lawn and garden battery and will operate the sprayer for up to four hours. Smaller batteries can be used but run-times will be shorter. Available from Northern Tool and Equipment #48737 (35AH) and #42533 (18AH) 	
<p>8. Connect the switch to battery</p>	<p>Connect the sprayer's <u>switch</u> to the battery using the following procedure:</p> <ol style="list-style-type: none"> a) Connect the <u>switch</u> cord red ring terminal to the positive (+) terminal of the battery. b) Connect the <u>switch</u> cord black ring terminal to the negative (-) terminal of the battery. <p>WARNING: Always connect in this sequence to avoid possible shock.</p>	

Assembly

WARNING

Batteries are hazardous because they contain caustic acid, can emit explosive gases, and can cause electric shock.

Caution must be exercised when making connections to a battery to avoid shock and contact with the acid, and to prevent any sparking that could lead to an explosion.

ALWAYS follow the safety instructions and steps listed below in *exact sequence* when connecting the sprayer's switch to the battery terminals.

10. Verify connection	Verify a complete connection has been made by checking with a DC voltmeter, or by <i>briefly</i> turning the <u>switch</u> to the ON position and listening for pump activation.
11. Disconnect after use	AFTER EACH USE, disconnect power to the sprayer by disconnecting the <u>pump cord</u> from the <u>switch cord</u> – <i>the switch cord may remain connected to the battery.</i> <i>NOTE: It is important to disconnect power to the sprayer when not in use for safety reasons. ALWAYS verify that the power has been disconnected or the switch is in the OFF position before adding chemicals or servicing.</i>
12. To disconnect permanently	When it is necessary to disconnect the sprayer's <u>switch</u> from the battery, use the following procedure: <ol style="list-style-type: none"> 1. Disconnect <u>sprayer's pump cord</u> from the <u>switch cord</u>. 2. Disconnect the <u>switch</u> from the battery as follows: <ol style="list-style-type: none"> a) Disconnect the <u>switch cord's black</u> battery ring terminal from the <i>negative (-)</i> terminal of the battery. b) Disconnect the <u>switch cord's red</u> battery ring terminal from the <i>positive (+)</i> terminal of the battery. <p>WARNING: Always disconnect in this sequence to avoid possible shock.</p>

Assembly

Check and test completed assembly.

WARNING

Check and test completed assembly

Serious injury could result from chemical leaks if sprayer is improperly assembled or the design of the sprayer is modified. Follow the steps below to ensure the sprayer is properly assembled. Never modify the sprayer design.

1. Check assembly	Check assembly to assure the sprayer is properly assembled and in safe working condition: <ul style="list-style-type: none">a) Check that the gun hose clamps are secure, and bolts/nuts are properly fastened.b) While it is unlikely that factory assembled components become loose, they should also be checked to make sure they are tight.
2. Test with water	Test the system for leaks with water: <ul style="list-style-type: none">a) Put a small amount of water in the tank.b) Connect the switch to the pump power cord and turn the remote switch ON. The pump is an "on demand" pump. When turned on, the pump will prime itself, and then turn off. When the gun trigger is squeezed, the pump will automatically start.c) Operate the spray gun by squeezing the gun trigger.d) Check for leaks throughout the system. If a leak is detected, fix the leak and re-test the system with water until no leaks are detected.

Machine Components

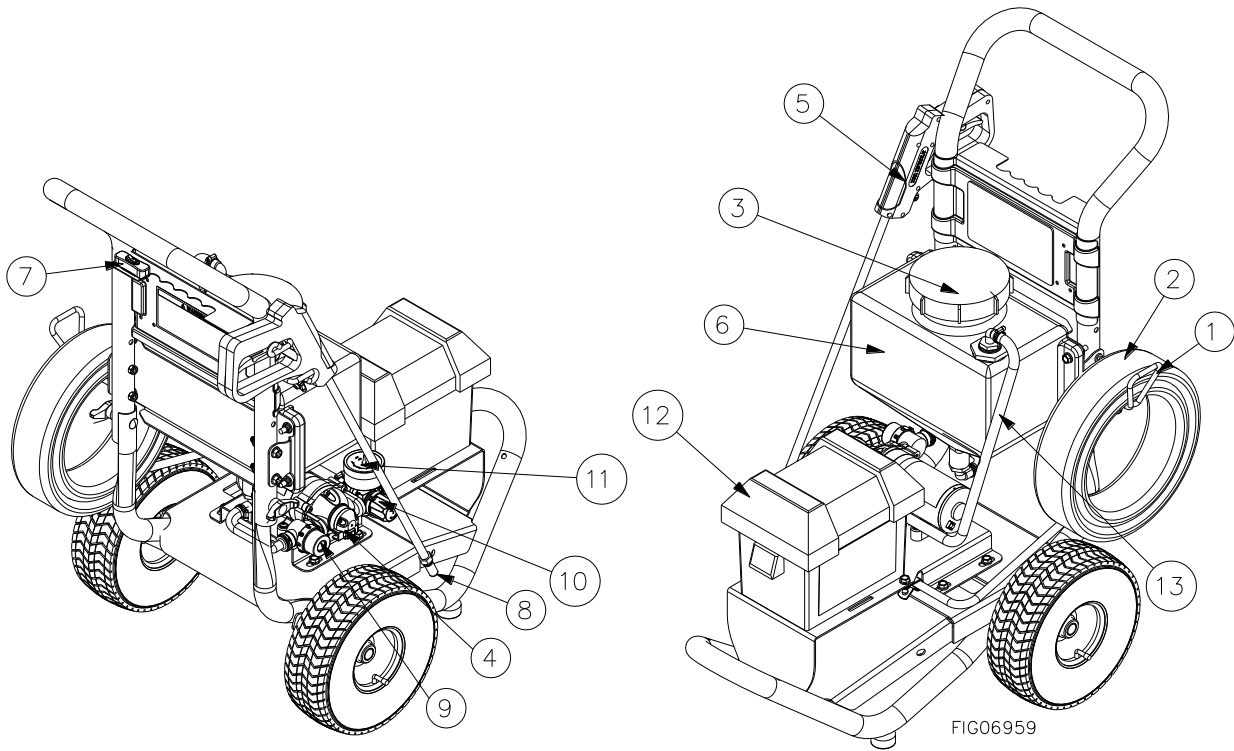

1. **Hose hook.** The hose hook provides a storage location for the gun hose on the cart.
2. **Gun Hose.** The 15-foot gun hose transfers chemical from the pump to the spray gun.
3. **Fill Cap.** The fill cap has a vent to allow air to enter the tank as the chemical is dispensed.
4. **Sprayer Pump.** The sprayer pump makes the chemical flow to the spray gun and out of the nozzle.
5. **Spray Gun.** Use the spray gun to apply chemical to specific areas. When the remote switch is in the ON position, the spray gun trigger is the pump ON/OFF control. Squeeze the trigger and the pump turns on, let go and the pump turns off.
6. **Sprayer Tank.** The 2.5-gallon sprayer tank holds the chemical.
7. **Power Switch.** The switch cord connects the battery to the pump and allows the operator to turn the pump on and off. The switch cord may be left connected to the battery when the sprayer is not in use.
8. **Spray Nozzle.** Spraying pattern adjusts from stream to cone by twisting the spray nozzle.
9. **Suction Strainer.** Suction strainer has clear removable bowl for easy cleaning. The strainer bowl also serves as the tank drain.
10. **Regulator.** This controls system pressure. Turn the red knob clockwise to increase pressure and counterclockwise to reduce pressure.
11. **Pressure gauge.** Use to monitor pressure in the system. The maximum pressure of the pump is 150psi.
12. **Battery box.** Marine grade battery box holds up to a 35Ah U1 group size lawn and garden battery.
13. **Bypass hose.** To maintain pressure at the nozzle, some fluid is returned to the tank through the regulator.

Operation – Important Safety Information

Now that you have completed and tested your assembly, there is some important safety and health information you need to know with regard to handling and spraying chemicals, as well as vehicle handling with the sprayer attached.

WARNING

Carefully read and make sure you understand the following safety information before using the sprayer.

General Chemical Safety:

WARNING

Heed the warnings below and follow all instructions carefully.
Improper handling of chemicals can result in serious injury or illness, or cause damage to the environment.

- **Chemical label.** ALWAYS READ and FOLLOW all chemical label instructions.
- **Licensing/regulation.** Refer to any applicable licensing restrictions or state/federal regulations with regard to the application of the particular chemical you plan to use.
- **Emergency procedures.** Before handling chemicals, carefully review the "Chemical Accident Procedures" listed later in this section, as well as the "Statement of Practical Treatment" on the chemical label.
- **Inhalation/contact.** ALWAYS take precautions to avoid inhaling or coming into contact with the chemical.
- **Personal protective equipment.** ALWAYS wear protective clothing, eye protection, and chemical-resistant gloves when filling, using and cleaning the sprayer. Wear additional protective gear (such as facemask or apron) as recommended on the chemical label.
- **Children/pets.** ALWAYS exercise extra caution around children. Keep sprayer and all spray materials away from children and animals.
- **Ventilation.** ALWAYS ensure there is adequate ventilation when mixing, pouring, or spraying.
- **Flammables.** NEVER use any flammable chemicals in the sprayer.
- **Chemical interaction.** ALWAYS flush the sprayer before switching chemicals. Different chemicals may interact dangerously with each other.
- **Chemical storage.** ALWAYS store chemicals in a properly labeled container and in a secure location per the manufacturer's recommendations.
- **Health monitoring.** Monitor the health of operators who are frequently exposed to chemicals, as recommended by the chemical label or local/federal regulations.

Operation – Important Safety Information

Chemical Application Safety:

WARNING

Caution must be used when spraying chemicals to avoid unsafe exposure to humans and the environment.

Heed the warnings below and follow all instructions carefully.

Before Spraying

- **Sprayer prep.** ALWAYS inspect and prepare the sprayer before use according to the directions provided in this manual.
- **Keep sprayer off.** Do not turn on power to the sprayer until ready to spray in order to avoid unintentional spray release.
- **Wind speed.** NEVER spray when wind speed exceeds 4 MPH in order to minimize spray drift.
- **Clear area/post.** ALWAYS keep the work area clear of people and pets. POST warning notices to restrict access by the public for the period recommended on chemical label.
- **Operator age.** You must be 16 years of age or older to operate this sprayer.

During Spraying

- **Over application.** DO NOT over apply chemical. Apply at a rate recommended by chemical manufacturer. Excess can be dangerous to humans, damage desirable plants, and contaminate soil and water sources.
- **Never point gun.** NEVER point the spray gun at people or animals.
- **Children/pets.** ALWAYS exercise extra caution when spraying near areas accessible to children and pets.
- **Eating/smoking.** DO NOT eat, drink, smoke, rub your eyes, or touch any part of your bare skin while handling chemicals and spraying.
- **Heat/flames.** DO NOT spray near open flames or sources of heat.
- **Spills.** ALWAYS clean up spills immediately per instructions on the chemical label.
- **Unattended.** ALWAYS turn off power to sprayer, and relieve system pressure before leaving sprayer unattended.
- **Troubleshooting.** ALWAYS refer to the safety instructions in the Troubleshooting Section before attempting any repairs.

After Spraying

- **Clean sprayer.** ALWAYS clean the sprayer immediately after use according to the directions provided in this manual.
- **Decontaminate.** ALWAYS decontaminate yourself immediately after you are finished spraying and handling chemicals. Wash all exposed areas of the body with soap and water and remove and launder clothing.
- **Chemical disposal/storage.** ALWAYS dispose of or store remaining chemicals properly as recommended on the chemical label.

Operation – Important Safety Information

Chemical accident procedures:

WARNING

Before you fill the sprayer, review the following information with regard to handling accidents.

Chemical spills, sprayer leaks, personal contamination, and poisoning are accident situations which you may encounter. **All require an immediate response – See instructions below.**

Sprayer leak	<p>In the event that the sprayer develops a leak while spraying chemicals, you must <i>immediately stop spraying.</i></p> <p style="padding-left: 40px;">Turn off power to the sprayer and follow the directions below, as applicable.</p>
Bodily chemical contact	<p>Personal contamination can occur when chemicals splash, spill, or spray directly onto a person.</p> <p>1. Follow the emergency first aid instructions on the chemical label listed in the "First Aid" or "Statements of Practical Treatment" section.</p> <p><u>General procedures include:</u></p> <p style="padding-left: 20px;">a) Eyes – immediately flush with water or follow other directions as specified on the chemical label.</p> <p style="padding-left: 20px;">b) Skin – immediately wash all contaminated skin surfaces with soap and water, or follow directions as specified on the chemical label.</p> <p style="padding-left: 20px;">c) Clothing – remove contaminated clothing immediately. Dispose of heavily contaminated clothing per the instructions on the chemical label for safe chemical/container disposal.</p> <p>2. Seek medical advice if instructed on the label, or if the victim experiences symptoms of harmful effects such as burning, swelling, nausea, chest pain, difficulty breathing, dizziness or confusion. When seeking medical advice, be sure to bring the chemical product label.</p>
Poisoning by ingestion or inhalation	<p>In case of poisoning from ingestion or inhalation:</p> <p>IF THE VICTIM HAS COLLAPSED OR IS NOT BREATHING, <u>CALL 911.</u></p> <p>Otherwise:</p> <p>1. If you are the victim, immediately seek assistance from nearby personnel because you may become incapacitated.</p> <p>2. Follow the emergency first aid instructions on the chemical label in the "First Aid" or "Statement of Practical Treatment" section.</p> <p>3. Call a poison control center for further advice. In the U.S., call 1-800-222-1222 to be automatically linked to the nearest certified poison control center. Have the chemical label available for reference.</p>

Operation – Important Safety Information

Chemical spills

Chemical spills must be quickly contained and properly cleaned up.

Refer to the chemical label for any specific clean-up instructions with regard to the chemical spilled.

General procedures include:

1. **Control** the spill by stopping the source of the spill. If the source of the spill is a container leak, place the leaking container in a larger, watertight container. Keep unprotected people away from the spill site.
2. **Contain** the spill so that it does not spread and get into water sources. Use a shovel or other tool to make a dike around the spill with soil, sod, or absorbent material.
3. **Clean up** the spill immediately -- Absorbent materials like ground corncobs or pet litter should be spread on the spill area to soak up the chemical. The contaminated material should then be shoveled into a leak proof container. Do not flush the spill area with water until you receive advice as directed below.
4. **Seek additional advice** from the chemical manufacturer and your state's regulatory agency regarding decontamination of the spill site:
 - *Chemical manufacturer.* The chemical label provides contact information for the chemical manufacturer.

Operation – Preparing the Sprayer for Each Use

If the sprayer has been used previously, it must be prepared BEFORE EACH SUBSEQUENT USE.

WARNING

Read instructions below carefully for inspecting and preparing the sprayer.
 Damaged or clogged equipment could result in leaks or uncontrolled spray.
 Leaks could result in injury to the operator or bystanders from chemical exposure, or cause damage to the environment.

Important safety rules:

- **Power off.** Make sure all power is OFF before cleaning, inspecting, or servicing the sprayer.
- **Guards / shields.** Make sure all guards and shields are replaced after servicing the sprayer.
- **Replacement parts.** If a part needs replacement, only use parts that meet the manufacturer's specifications. Replacement parts that do not meet specifications may result in a safety hazard or poor operation of the sprayer.

1. Ensure sprayer attached	Ensure the sprayer is securely attached to the vehicle.
2. Ensure tank empty	Ensure the sprayer has been thoroughly flushed and drained of all residual chemical from prior uses.
3. Clean suction strainer	<p>Clean the suction strainer of any chemical residue.</p> <p>It is important to clean the suction strainer before and after each use to ensure it is not clogged and to prevent residual chemicals from contaminating sprayer contents.</p> <ul style="list-style-type: none"> a) USING RUBBER GLOVES, remove strainer bowl. b) Run the suction strainer under fresh water to remove debris. c) Replace the suction strainer bowl.
4. Inspect & repair	<p>Inspect and test the sprayer thoroughly:</p> <ol style="list-style-type: none"> 1. Inspect hoses for exposed mesh and holes. Replace all worn or damaged hoses. 2. Inspect tank and fittings for cracks and leaks. Replace all damaged fittings with original NorthStar parts. 3. Check to be sure all other nuts, bolts, and screws are tight. 4. Check wheels and tires. Make sure wheel retainers are tight and tires are inflated. 5. <i>Partially fill tank with plain water and spray to test for leaks.</i> Repair as needed. <p><i>IMPORTANT: After any repair work has been done, ALWAYS test for leaks with water one final time before using.</i></p>

Operation – Using the Sprayer

Step One: Assess wind conditions and clear work area.

Before you decide to spray, you must determine whether wind conditions are suitable. You must also restrict access to the work area to ensure the safety of bystanders.

⚠ WARNING

If spraying outdoors, do not spray if wind speeds are greater than 4 MPH or if there are bystanders in the intended spray area.

1. Assess wind speed	Assess weather conditions to ensure that it is not too windy to spray. DO NOT SPRAY if wind speeds are greater than 4 MPH. <i>Visible indication of wind speed:</i> If leaves are in constant motion or there is any branch movement, DO NOT spray because the wind is too strong.
2. Clear work area	Clear the work area of all bystanders and pets. Restrict access by the public for the period recommended on chemical label.

Operation – Using the Sprayer

Step Two: Fill the sprayer.

⚠ WARNING

ALWAYS wear personal protective equipment as directed on the chemical label when handling chemicals.

Long pants and sleeves, chemical resistant gloves, and eye protection are strongly recommended. Additional protective gear may be required.

The motor surface temperature can reach temperatures over 70° C. In order to avoid scalding, wear gloves during operation of the sprayer.

Fill the sprayer using the following steps:

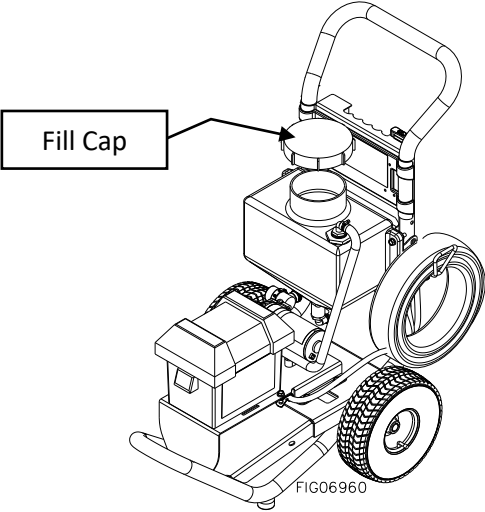
1. Review safety information	Review the "Operation – Important Safety Information" related to <u>General Chemical Safety</u> and <u>Chemical Accident Procedures</u> provided in this manual.
2. Choose safe mixing/loading area	Choose a safe chemical mixing and loading area. - Choose, well-ventilated area away from unprotected people, animals, food, and other items that might become contaminated.
3. Wear personal protective equipment	Wear personal protective equipment as directed on the chemical label. - Note that additional equipment may be specified for mixing and loading activities.
4. Turn off sprayer	Turn OFF power to the sprayer before filling.
5. Remove fill cap	Remove the fill cap located on top of the sprayer. <div style="text-align: right;">  <p style="text-align: right; font-size: small;">FIG06960</p> </div>
6. Ensure correct chemical to be sprayed	Ensure tank is flushed of all chemicals from prior uses. - Chemicals can interact dangerously when mixed, and residue chemicals are also a health hazard.

Operation – Using the Sprayer

6. Fill tank	Add chemical to tank through fill cap: <ul style="list-style-type: none">a) Confirm the chemical/water dilution ratios specified on the chemical label.b) Determine chemical and water volumes needed for the planned application, taking into consideration that maximum tank capacity is 2.5-gallons. <i>Note: Only purchase and mix as much chemical as you need for the planned application in order to minimize chemical over application and the need for storing unused chemicals.</i>c) Add chemical to the tank through the fill cap. <i>If the chemical is not pre-mixed, add water and chemical concentrate in the order prescribed on the label.</i>
7. Ensure chemical mixed	Ensure chemical is thoroughly mixed in tank. <ul style="list-style-type: none">- Stirring device should be made of metal or plastic, non-chemical absorbing material, and then properly cleaned and stored after use.
8. Replace fill cap	Replace fill cap and tighten securely.

Operation – Using the Sprayer

Step 3: Operate the sprayer.

⚠ WARNING

ALWAYS wear personal protective equipment as directed on the chemical label when spraying.

Long pants and sleeves, chemical-resistant gloves, and eye protection are strongly recommended. Additional protective gear may be required.

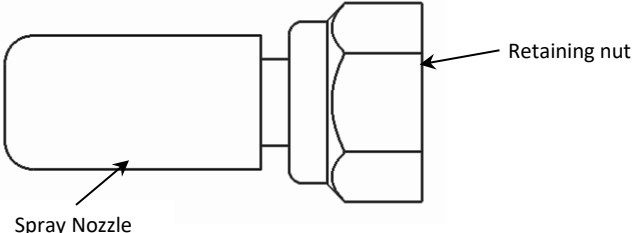
1. Review safety information	Review the "Operation – Important Safety Information" related to <u>Chemical Application Safety</u> provided in this manual.
2. Wear personal protective equipment	Wear personal protective equipment as directed on the chemical label.
3. Turn on power	<p>Turn on the power to the sprayer.</p> <ol style="list-style-type: none"> 1. Verify the switch cord is connected to the pump power cord. 2. Turn the switch to the "ON" position. <p><i>Note: The pump will start automatically when power is turned on.</i></p>
4. Squeeze trigger & adjust nozzle	<p>To spray, squeeze the gun trigger.</p> <p>- Twist the spray nozzle to adjust from a straight stream to hollow cone spray pattern, as recommended on the chemical label for proper delivery rate.</p> <p><i>Note: It is not unusual for the operator to be exposed to chemical drips while adjusting the nozzle – gloves should be chemical resistant.</i></p> <div style="text-align: center; margin-top: 20px;">  </div>

Operation – Using the Sprayer

5. Adjust pressure regulator

Turn pressure regulator knob to adjust outlet pressure

1. Turn knob clockwise to increase pressure.
2. Turn knob counterclockwise to decrease pressure

Note: If the pressure regulator knob is completely tightened, the pressure setting will be higher than the pressure switch on the pump (150 psi). This allows the pump to operate as a demand pump and turn on only when spraying.

Note: Regulator should be adjusted so pump does not cycle on and off during operation.

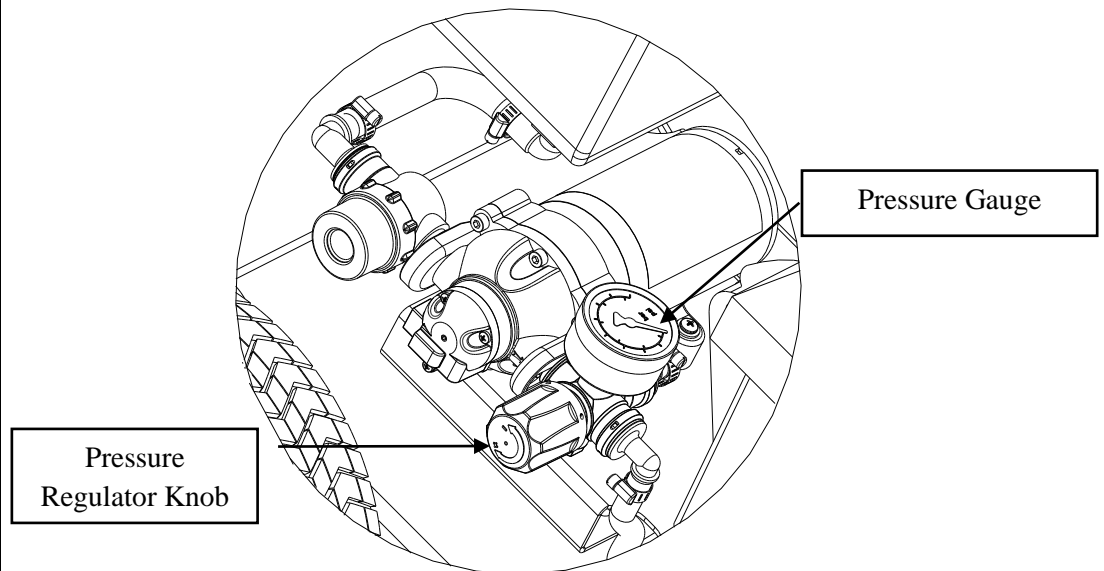

Figure 2 - FIG06961

6. Begin agitation if needed

Some formulations of liquid chemicals do not remain in solution and should be agitated to maintain a uniform mix.

The pressure regulator on this sprayer can be used as an agitator. If the pressure is set below the pump's pressure switch setting (150 psi), the pump will continue to run even when not spraying. Fluid will be diverted through the pressure regulator back to the tank. This bypass fluid will keep the contents of the tank well-mixed.

Operation – Using the Sprayer

6. Leaving unattended

If the sprayer must be left unattended at any time:

- a) Disconnect power to the sprayer.
- b) Relieve system pressure by depressing the gun trigger.

7. Discontinue use if clogged or inoperative

If the sprayer becomes clogged or inoperative during use, *discontinue use immediately.*

- DO NOT attempt to service while chemicals are in the sprayer and power is connected.
- Return to service area to review instructions for troubleshooting before attempting to service.

***Note:** A reserve, clean container capable of holding at least 2.5 OR 3 gallons should be kept for use when the sprayer tank needs to be emptied temporarily for repairs. It is advisable to purchase a reserve tank suitable for chemical storage from Northern Tool + Equipment for use in these circumstances. The container should be properly labeled as to its contents if it is used.*

Operation – Using the Sprayer

Step Four: Clean sprayer and decontaminate after use.

When done using the sprayer, it is important to clean the sprayer and decontaminate yourself. Do not store the sprayer with chemicals in the tank, as it is unsafe and could also result in damage to the equipment.

 WARNING

Clean-up and decontamination procedures must be followed after each use.

Improper equipment clean-up and disposal of chemicals can result in dangerous chemical exposure to humans and the environment, as well as equipment damage.

Personal decontamination is required after spraying to minimize unsafe exposure to chemicals and potential illness.

1. Drain tank	<p>If there is excess chemical left in the tank, drain the tank:</p> <ul style="list-style-type: none"> a) Disconnect power to the sprayer and relieve system pressure by depressing the gun trigger. b) Find a suitable container in which to drain the unused chemical. Place it under the strainer bowl. c) While wearing rubber gloves, eye protection, and all other required personal protective equipment, remove the strainer bowl and allow chemical to drain into container. d) When tank stops draining, replace cap. Tighten securely.
2. Unused chemical	<p>Properly store or dispose of unused chemical:</p> <ul style="list-style-type: none"> a) <u>If the unused chemical is to be stored for future use:</u> Store all unused chemical in its original, or a suitably marked, container in a secure location out of the reach of children & animals. b) <u>If remaining chemical is to be disposed:</u> Properly dispose of the remaining chemical and its container per the chemical manufacturer's recommendation and according to local hazardous waste disposal regulations.
3. Flush sprayer and nozzle components	<p>Flush the sprayer per the chemical manufacturer's recommendations. A general procedure is as follows:</p> <ul style="list-style-type: none"> a) Add fresh water to the tank. b) Reconnect power to the sprayer. c) Operate the spray gun and discharge all rinse water onto an area that can accept dilute chemical application. d) After flushing, disconnect power to the sprayer and be sure all system pressure is relieved by squeezing the gun trigger.
4. Decontaminate & launder	<p>Decontaminate yourself after you are finished handling chemicals:</p> <ul style="list-style-type: none"> a) Remove all clothing worn during spraying and chemical handling. b) Wash all exposed parts of the body with soap and water. c) Launder clothing separately from other wash.

Storage

When not in use, store the sprayer indoors. For long term or winter storage, prepare the sprayer by running **RV antifreeze** (DO NOT USE automotive antifreeze) through the system. This will keep internal parts lubricated, protect against corrosion, and keep the unit from freezing.

CAUTION

The sprayer will be damaged if it freezes.

Protect the sprayer from freezing during storage by following the instructions below.

Prepare for Storage:

1. Flush with water	Fill the tank with fresh water and run through the system. Operate the spray gun until the system is completely flushed. DO NOT add antifreeze before flushing the system.
2. Add antifreeze	Pour 1 gallon of RV antifreeze (DO NOT USE automotive antifreeze) into the tank. <i>Note: RV antifreeze is non-toxic and biodegradable and generally safer for the environment than automotive antifreeze.</i>
3. Spray briefly	Turn on the pump motor and squeeze the gun trigger briefly until fluid sprays.

Removing from storage:

1. Drain	Drain the antifreeze left in the tank through the strainer bowl into a suitable container
2. Flush with water	Fill the tank with fresh water and run through the system. Operate the spray gun until the system is completely flushed. Be sure to set up containers to capture the antifreeze flush water. DO NOT add chemical back into the sprayer before flushing the system.
3. Disposal	Dispose of the antifreeze and flush water properly.

Troubleshooting

⚠ WARNING

Before troubleshooting or attempting to service, read the following safety rules to avoid accidental exposure to chemical and also risk of electric shock.

Note: A reserve, clean container capable of holding at least 2.5 gallons should be kept for use when the sprayer tank needs to be emptied temporarily for repairs. It is advisable to purchase a reserve tank suitable for chemical storage from Northern Tool + Equipment for use in these circumstances. The container should be properly labeled as to its contents if it is used.

Before attempting to service the sprayer:

1. Personal protective equipment	Wear personal protective equipment as directed on the chemical label while servicing your sprayer.
2. Review troubleshooting table	Review the Troubleshooting Table below for the type of problem you are experiencing. However, DO NOT attempt to repair until the steps listed below are followed.
3. Empty and flush	If the cause listed for your problem is Clogged intake tube, Clogged suction strainer, or Worn spray gun nozzle: empty the tank and flush the sprayer with water as directed in the section, "Operation – Step Four". <i>- In order to avoid accidental exposure to chemicals, never attempt to unclog the intake tube or suction strainer, or service the spray gun nozzle, until the tank has been emptied and the sprayer flushed with water.</i>
4. Disconnect power/relieve pressure	Disconnect power to the sprayer and be sure all system pressure is relieved by squeezing the gun trigger.
5. Perform repairs	Follow the directions provided in the troubleshooting table to repair the sprayer. <i>NOTE: Never try to unclog the sprayer nozzle by blowing through it.</i>
6. Test after servicing	After servicing, ALWAYS test the sprayer for leaks with plain water before using.

PROBLEM	CAUSE	SOLUTION
Pump will not turn on	Bad electrical connection	Check battery connections
	Fuse blown	Replace fuse
	Short in wires	Check condition of wires
	Low voltage	Check voltage
Low flow/pressure	Clogged intake tube	Remove obstruction
	Clogged suction strainer	Clean suction strainer
	Low voltage	Check voltage
Poor spray distribution	Clogged nozzle	Remove obstruction
	Suction strainer clogged	Clean suction strainer
	Worn spray gun nozzle	Replace nozzle
Pump cycles while not spraying	Leak in the system	Tighten leaking hose clamps or fittings, replace spray gun

Specifications

Electrical System Requirements

Electrical connection	12 VDC
Amp draw from pump	10.5 Amps

Sprayer Specifications

Maximum GPM	1.5 GPM (5.7 Liters/min.)
Maximum Pressure	150 PSI (10.3 Bar)

Tank Maximum Capacity 2.5-gallons (9.5 Liters)

Overall Dimensions 28" x 22" x 38"
(71.1cm x 55.9cm x 96.5cm)

Dry Weight / Weight full of water 58 lb. / 78 lb. (26.3 kg. /35.4kg)

Battery Box Size (Internal) 8-1/4" x 5-1/2" x 7-7/8"
(210mm x 140mm x 200mm)

*Before using any chemical, check to ensure the chemical is compatible with all materials in the system.

The noise emissions from this product do not exceed 70 dB(A).

Note: Pumping any petroleum-based fluid (gasoline, diesel, kerosene, oil) will severely damage the pump.

The manufacturer reserves the right to make improvements in design and/or changes in specifications at any time without incurring any obligation to install them on units previously sold.

Any Questions, Comments, Problems or Parts Orders

Call NorthStar Product Support 1-800-270-0810

Exploded View & Parts List – Rev A

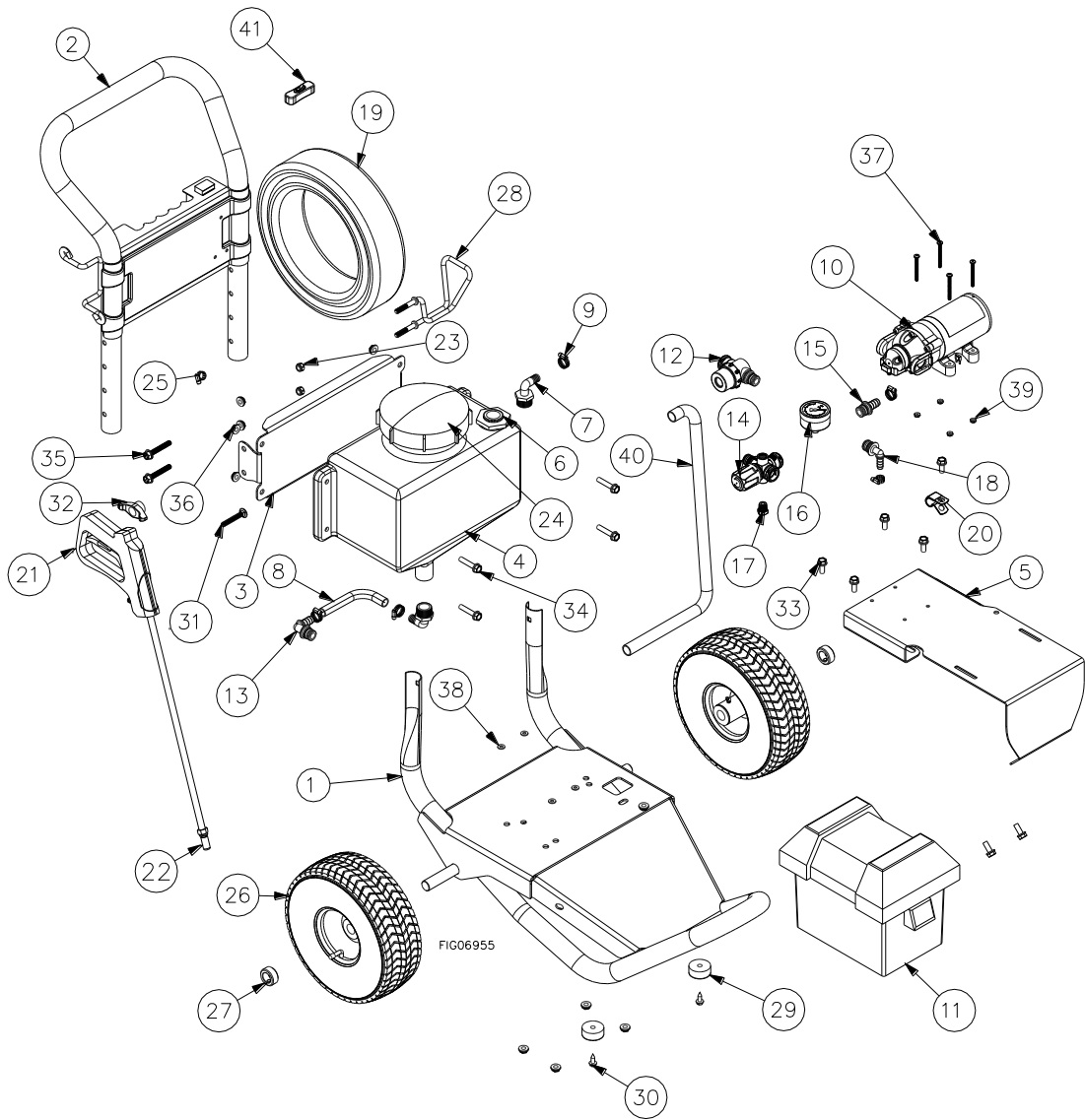

Exploded View & Parts List – Rev A

Ref#	Part#	Description	Qty
1	788537	Base Weldment	1
2	802875	Handle Weldment	1
3	802362	Tank Mounting Bracket	1
4	802361	Tank, 2.5gal w/ Cap	1
5	802363	Mounting Bracket	1
6	5370	¾" Bulkhead	1
7	779269	Fitting, ¾" NPT x ½" HB Elbow	2
8	802369	Hose, ½" Preform	1
9	777119	1/2" Hose Clamp	4
10	26815152	NorthStar 1.5gpm pump	1
11	777352	Battery Box	1
12	798855	Inlet Filter	1
13	787197	Fitting, QC x ½" Elbow	1
14	792943	Regulator Assembly	1
15	787193	Fitting, QC x ½" HB	1
16	792832	Pressure Gauge	1
17	779859	Plug, ¼" NPT	1
18	787196	Fitting, QC x 3/8" HB Elbow	1
19	802854	Hose, 3/8" x 16' yellow AG	1
20	777110	Strain Relief	1
21	798573	Spray Gun	1
22	799022	Nozzle tip	1
23	777495	Nut, Nyloc M8-1.25 Zinc	2
24	802379	Tank Cap	1
25	30746	Hose Clamp, 3/8"	2
26	788813	Wheel, 10"	2
27	305200	Wheel Retainer	2
28	779761	Hose Hook	1
29	2215	Bumper	2
30	82232	Screw, ½" x ¾" self-tapping	2
31	82233	Bolt, Carriage 5/16"-18 x 2"	2
32	38578	T-Handle Knob	2
33	82015	Bolt, 5/16"-18 x ¾"	7
34	82017	Bolt, 5/16"-18 x 1-1/2"	4
35	82018	Bolt, 5/16"-18 x 2"	2
36	82019	Nut, 5/16"-18 serrated flange	13
37	82307	Screw, #10-24 x 1.25"	4
38	82068	Washer, #10 Flat	4
39	82065	Nut, #10 Nyloc	4
40	30160	Hose, ½" Bypass	24"
41	802378	Wire Harness	1

Pump Exploded View

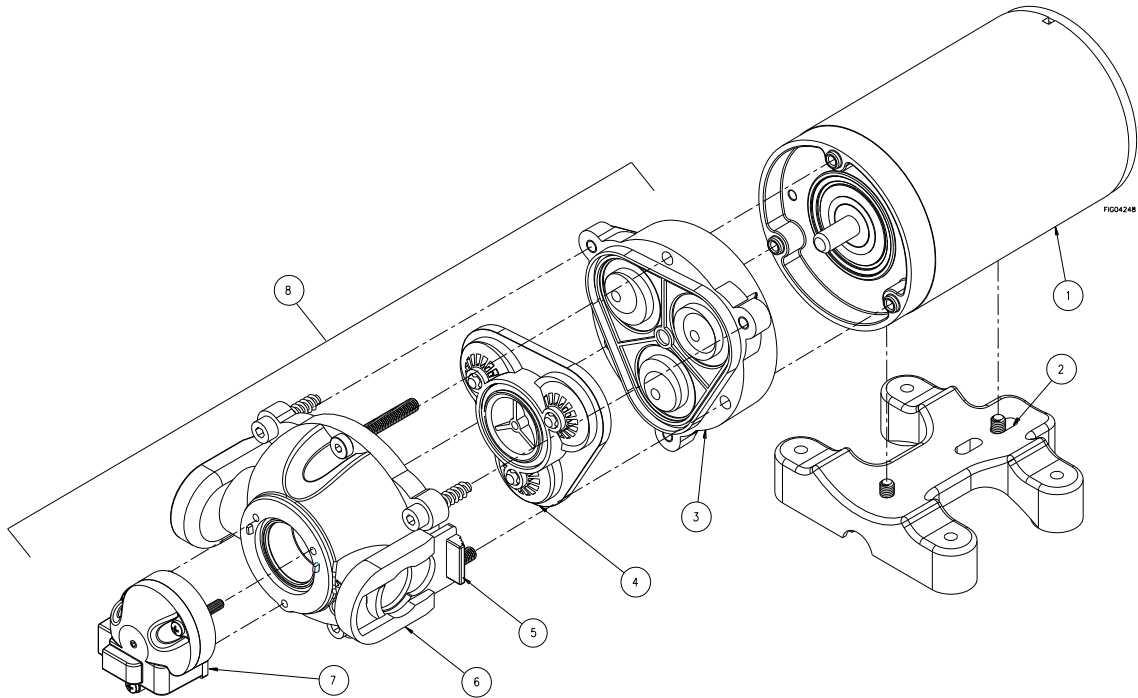

Ref#	Part#	Description	Qty
1	800136	Motor assembly	1
2	800428	Base plate assembly	1
3	797013	Diaphragm assembly	1
4	798397	Valve plate assembly	1
5	787015	Quick connect clip	2
6	797105	Upper housing assembly	1
7	797407	Pressure switch assembly	1
8	A26815152	Complete pump head assembly	1
N/A	787381	Replacement fuse	1

Any Questions, Comments, Problems or Parts Orders
Call NorthStar Product Support 1-800-270-0810

Limited Warranty

Dear Valued Customer:

Use this product properly and enjoy the benefits from its high performance. By purchasing a NorthStar product, you show a desire for quality and durability. Like all mechanical equipment this unit requires a due amount of care. Treat this unit like the high-quality piece of machinery it is. Neglect and improper handling may impair its performance. Please thoroughly read the instructions and understand the operation before using your product. Always contact NorthStar Product Support at 1-800-270-0810 prior to having any service or warranty work performed, as some services performed by parties other than NorthStar approved service centers may void this warranty. This warranty is in lieu of any other warranty expressed or implied and NorthStar assumes no other responsibility or liability outside that expressed within this warranty.

Limited Warranty

NorthStar shall warranty any piece of equipment manufactured, or parts of equipment manufactured, to be free from defects in material or workmanship for a period of:

Item #	Warranty Period
999888	2 years from date of purchase by user

“Consumer use” means personal residential household use by a consumer. “Commercial use” means all other uses, including use for commercial, income producing or rental purposes or when purchased by a business.

This warranty applies to the original purchaser of the equipment (verification of purchase, in the form of a receipt, is the responsibility of the buyer), is non-transferable, and covers some parts and no labor. Parts will be replaced or repaired at no charge, except when the equipment has failed due to lack of proper maintenance. If a part is no longer available, the part may be replaced with a similar part of equal function. Any misuse, abuse, alteration or improper installation or operations will void warranty. Determining whether a part is to be replaced or repaired is the sole decision of NorthStar. NorthStar will not provide for replacement of complete products due to defective parts. Any costs incurred due to replacement or repair of items outside of a NorthStar approved facility is the responsibility of the buyer and not covered under warranty. Transportation costs to and from service center is the responsibility of the customer.

In addition to the normal warranty, NorthStar shall warrant any normal wear item from defects in material or workmanship for a period of 90 days from the date of purchase by user. Normal wear items include, but are not limited to, pump, hoses, couplers/fittings, tank drain cap, gun, nozzle, on/off switch, decals, wiring, strainer, barbs, tees, fittings, hardware.

This warranty specifically excludes the following: failure of parts due to damage caused by accident, fire, flood, windstorm, acts of God, applications not approved by NorthStar in writing, corrosion caused by chemicals, use of replacement parts which do not conform to manufacturer’s specifications, damage related to rodent and/or insect infestation and damage caused by vandalism. Additional exclusions: loss of running time, inconvenience, loss of income, or loss of use, including any implied warranty of merchantability of fitness for a specific use. Also, outdoor equipment needs periodic parts and service to perform well, and this warranty does not cover instances when normal use has exhausted the life of a component.

This warranty does not cover any personal injury or damage to surrounding property caused by failure of any part. Repair or replacement of parts does not extend the warranty period.

Please fill in the following information and have it on hand when you call in on a warranty claim.

Customer Number: _____

Date of Purchase: _____

NorthStar Serial Number: _____

Item Number: _____

⚠ WARNING: This product can expose you to Naphthalene, which is known to the State of California to cause cancer.

For more information go to www.P65Warnings.ca.gov.



Assembled by
Northern Tool + Equipment Co., Inc.
Burnsville, MN 55306
NorthernTool.com