



M999884A.1

ITEM NUMBER: 999884

SERIAL NUMBER: _____

Owner's Manual

Instructions for Assembly, Testing, Operation, Servicing, and Storage
**Disinfecting Skid Sprayer: For use with disinfecting bleach solutions
up to 1800ppm****

⚠ WARNING

READ and UNDERSTAND the Owner's Manual completely before using this sprayer. Assemble, test, and use only in accordance with the Owner's Manual instructions.

DO NOT mix bleach with any other chemicals. Not for use with any other chemicals. System designed for use with disinfecting bleach concentrations only.

READ and FOLLOW chemical label instructions. Bleach is a hazardous chemical.

KNOW emergency procedures BEFORE handling chemicals. Sprayer leaks, bodily chemical contact, poisoning, and spills require immediate response.

AVOID inhaling, ingesting, or coming into contact with any chemicals.

WEAR personal protective gear when filling, using, cleaning, and servicing the sprayer.

KEEP sprayer and spray materials away from children and pets.

DO NOT START sprayer until ready to spray in order to avoid unintentional spray release.

EXERCISE CAUTION in vehicle handling when driving with filled sprayer to avoid loss of control or rollover.

ALWAYS keep a fire extinguisher rated "ABC" nearby

Improper use of the sprayer or handling of chemicals could result in serious injury or illness to the operator or nearby persons/animals or could cause damage to the environment.

Equipment Protection Quick Facts

Inspect Upon Delivery: FIRST! Inspect for missing or damaged components. See "*Unpacking*" section for where to report missing or damaged parts.

Add Engine Oil: Engine is shipped **without oil**. See engine manual for instructions on capacity and viscosity recommendations.

Check Pump Oil Level: Pump is shipped **with** oil. Check pump oil level before starting. See pump manual for instructions on capacity and viscosity recommendations.

Chemical Spraying: Use only chemicals compatible with all materials in the spraying system. See "Specifications" section for a list of materials.

Storage: Do not allow water to freeze in the pump, hose, or spray gun(s). See "Storage" for more information.

Maintenance Schedule: Engine and pump require periodic inspection and servicing to keep sprayer functioning efficiently. See engine manual and pump manual for frequency of servicing.

This sprayer is recommended for use in spraying bleach. The sprayer will be damaged, and warranty voided if used to apply any petroleum-based product (gasoline, diesel, kerosene, or oil). The sprayer should not be used to transfer any product intended for human consumption. **THE SPRAYER MUST NOT BE USED FOR OTHER PURPOSES ONCE IT HAS BEEN USED FOR SPRAYING BLEACH. Any chemical will leave some residual in the tank liner or sprayer components, even after the sprayer has been properly cleaned. These residual chemicals can have unexpected effects on future uses. This sprayer should not be used by people with reduced physical, sensory or mental capabilities or lack of experience and knowledge.

Any Questions, Comments, Problems, or Parts Orders

Call NorthStar Product Support 1-800-270-0810

Hazard Signal Word Definitions





	<p>This is the safety alert symbol. It is used to alert you to potential personal injury hazards. Obey all safety messages that follow this symbol to avoid possible injury or death.</p>
	<p>DANGER (red) indicates an imminently hazardous situation which, if not avoided, will result in death or serious injury.</p>
	<p>WARNING (orange) indicates a potentially hazardous situation which, if not avoided, could result in death or serious injury.</p>
	<p>CAUTION (yellow) indicates a potentially hazardous situation which, if not avoided, may result in minor or moderate injury.</p>
	<p>CAUTION (yellow) used without the safety alert symbol indicates a potentially hazardous situation which, if not avoided, may result in property damage.</p>

fig01453

Table of Contents

Intended Use	4
Summary of Important Safety Information	5
During Assembly	
During Operation	
• General Chemical Safety	
• Chemical Application Safety	
• Transporting Safety	
• Chemical Accident Procedures	
During Storage / Troubleshooting	
Warning Label Locations	8
Unpacking	9
Unpacking	9
Assembly	
Step One: Attach hose reel handle to the hose reel	10
Step Two: Install lance clips	10
Step Three: Attach lance extension and/or nozzle to spray gun	11
Step Four: Attach spray gun to hose	12
Step Five: Attach the sprayer to the vehicle	12
Step Six: Check and test completed assembly	13
Machine Components	14
Operation	
Operation - Important Safety Information	15
• General Chemical Safety	
• Chemical Application Safety	
• Transportation Safety	
• Chemical Accident Procedures	
Operation - Preparing the Sprayer for Each Use	
Step One: Inspect/Repair	19
Step Two: Fueling	21
Operation - Using the Sprayer	
Step One: Assess wind conditions and clear work area	22
Step Two: Check and set accumulator pressure	22
Step Three: Fill the sprayer	23
Step Four: Operate the sprayer	25
Step Five: Clean sprayer and decontaminate after use	29
Storage	31
Preparing for storage	
Removing from storage	
Troubleshooting	32
Specifications	33
Sprayer Exploded Views	34
Pump Exploded View	36
Limited Warranty	39
California Proposition 65 Information	40

Intended Use

The sprayer is intended for use in spraying disinfecting bleach solutions of 1800ppm or less.

SPRAYING CHEMICALS:

Hazardous chemicals must be handled with caution as directed throughout this manual and on the chemical label.

A bleach concentration higher than 1800ppm will reduce the life of the product.

The sprayer is intended for use in spraying chemicals in liquid form only. The sprayer is NOT intended for use in spraying chemicals in dry or aerosolized form, or for use with fumigants.

Always flush the sprayer after each use to clean the chemical out of the pump, hoses, and spray gun. The life of the sprayer will be shortened if it is not flushed after each use.

THE SPRAYER MUST NOT BE USED FOR OTHER PURPOSES ONCE IT HAS BEEN USED FOR BLEACH. Any chemical will leave some residual in the tank liner or sprayer components, even after the sprayer has been properly cleaned. These residual chemicals can have unexpected effects on future uses.

NOTE: The sprayer will be damaged, and warranty voided, if used to apply any petroleum-based product (gasoline, diesel, kerosene, or oil).

Contact NorthStar Product Support at 1-800-270-0810 for any questions about the appropriate use of the sprayer and/or optional accessories.

Summary of Important Safety Information

⚠ WARNING

Read and understand **this owner's manual** completely before using the sprayer.
Read each **chemical label's instructions** before handling the chemical.

Improper use of the sprayer or handling of chemicals could result in serious injury or illness for the operator or nearby persons/animals, or cause damage to the environment.

LISTED BELOW is a summary of safety information of particular importance. See individual sections of this owner's manual for more details.

----- DURING ASSEMBLY -----

- **CHECK and TEST completed assembly** as directed in this manual. Serious injury could result from chemical leaks if sprayer is improperly assembled.
- **DO NOT MODIFY sprayer design.**

----- DURING OPERATION -----

General Chemical Safety

- **READ and FOLLOW each chemical label's instructions and warnings.**
- **DO NOT spray undiluted bleach.** Always dilute strictly in accordance with the directions.
- **CONSULT chemical label for correct ratios.** Never mix bleach solutions stronger than 1800ppm, incorrect ratios could release harmful gases.
- **DO NOT use for any other purposes once the sprayer has been used with bleach.**
- **DO NOT mix bleach with other chemicals.**
- **AVOID inhaling, ingesting, or coming into contact with any chemicals.**
- **KNOW applicable licensing and regulatory requirements** for the chemical you plan to use.
- **KNOW emergency procedures before handling chemicals.** Carefully review "Chemical Accident Procedures" listed below and later in this manual. Also see First Aid instructions on the chemical label.
- **WEAR protective clothing, eye protection, and chemical resistant gloves** when filling, using and cleaning the sprayer. Wear additional protective gear, such as facemask or apron, as recommended on the chemical label.
- **EXERCISE EXTRA CAUTION around children and pets.** Keep sprayer and spray materials away from them at all times.
- **DO NOT MIX OR POUR chemicals in an enclosed, unventilated area**
- **DO NOT USE flammable** in the sprayer.
- **STORE chemicals in a correctly labeled container and in a secure location.**
- **MONITOR the health of operators frequently exposed to chemicals,** as recommended by the chemical label or local/federal regulations.

Chemical Application Safety

Before Spraying

- **INSPECT and PREPARE sprayer before each use** as directed in this manual.
- **FOLLOW INSTRUCTIONS for SAFELY FUELING the engine.** Gasoline is flammable and can explode. Always use caution when handling gasoline.
- **DO NOT START sprayer until ready to spray** in order to avoid unintentional spray release.
- **WEAR ADDITIONAL PERSONAL PROTECTIVE EQUIPMENT if you will be spraying overhead.** You will be exposed to much more chemical fallout in these applications. Wear chemical resistant head and neck protection, full face mask or half face mask with sealed goggles and consider using a respirator.
- **DO NOT SPRAY when wind speed exceeds 4 MPH** in order to minimize spray drift.
- **KEEP sprayer and spray materials away from children/pets.**
- **DO NOT ALLOW anyone younger than 16 to operate sprayer.**

Summary of Important Safety Information

During Spraying

- **DO NOT OVERAPPLY chemical.** Apply at rate recommended by chemical manufacturer. Excess can be dangerous to humans/animals, damage desirable plants, and contaminate soil and water sources.
- **DO NOT EAT, DRINK, SMOKE, RUB YOUR EYES, or TOUCH YOUR BARE SKIN while handling chemicals and spraying.**
- **NEVER POINT THE SPRAY GUN at people or animals.**
- **DO NOT SPRAY near open flames or sources of heat.**
- **ALWAYS HOLD THE SPRAY GUN FIRMLY when using it to spray at higher pressures** in order to prevent gun from whipping. Keep good footing and balance at all times.
- **EXERCISE EXTRA CAUTION when spraying near areas accessible to children and pets.**
- **CLEAN up spills immediately** per instructions on the chemical label.
- **TURN OFF vehicle and set brake or block wheels, TURN OFF sprayer, and RELIEVE system pressure** before leaving sprayer unattended.
- **SEE Troubleshooting section of this manual before attempting any repairs.** Wear personal protective equipment and follow safety instructions.

After Spraying

- **CLEAN sprayer immediately after use** according to the directions provided in this manual.
- **DECONTAMINATE yourself after you are done spraying** and have cleaned the sprayer. Wash all exposed areas of the body with soap and water and remove and launder clothing.
- **DISPOSE OF or STORE remaining chemicals in secure storage with correctly marked container.**

Transporting Safety

- **READ safety instructions** in your vehicle manual with regard to carrying heavy cargo loads.
- **DO NOT ALLOW drivers younger than 16** to drive the vehicle with the filled sprayer attached.
- **MAKE SURE SPRAYER IS SECURELY ATTACHED to vehicle.**
- **EXERCISE CAUTION in vehicle handling when driving with filled sprayer** to avoid loss of control or rollover.
 - **Keep speed to a minimum** so you can maintain control. Reduce speed prior to turns.
 - **Allow for more distance to stop.**
 - **Avoid any sudden steering maneuvers, starts, or stops** that could create liquid sloshing in the sprayer and instability.
- **SLOW DOWN and EXERCISE EXTRA CAUTION on sloped or uneven terrain.** Pick the most level route possible across fields--drive up and down slopes when necessary, rather than across. Use a vehicle equipped with a roll over protection system (ROPS) if you will be working on non-level terrain.
- **BE AWARE that visibility may be reduced** when making turns or backing up.
- **DO NOT RIDE or TRANSPORT cargo on the sprayer.**
- **TURN OFF both sprayer and vehicle, and SET BRAKES** before leaving unattended.

Summary of Important Safety Information

Chemical accident procedures

Immediate response is necessary in the event of sprayer leaks, bodily chemical contact, poisoning, or spills. See instructions below:

Sprayer leak	If the sprayer develops a leak, <i>immediately stop spraying</i>. Turn off power to the sprayer and follow directions below, as applicable.
Bodily chemical contact	<p>Personal contamination can occur when chemicals splash, spill, or spray directly onto a person.</p> <ol style="list-style-type: none"> 1. Immediately follow First Aid instructions on <u>chemical label</u>. <u>General procedures can include:</u> <ol style="list-style-type: none"> a) Eyes – immediately flush with water. b) Skin – wash all contaminated skin surfaces with soap and water. c) Clothing – remove contaminated clothing. Dispose of heavily contaminated clothing per chemical label instructions. 2. Seek medical advice if instructed on the label or the victim experiences symptoms of harmful effects. Bring the chemical label for reference.
Poisoning by ingestion or inhalation	<p>In case of poisoning from ingestion or inhalation: <i>If the victim has collapsed or is not breathing, <u>call 911</u>.</i> Otherwise:</p> <ol style="list-style-type: none"> 1. If you are the victim, immediately seek assistance from nearby personnel because you may become incapacitated. 2. Immediately follow first aid instructions on <u>chemical label</u>. 3. Call a poison control center for further advice. In the U.S., call 1-800-222-1222. Have the chemical label available for reference.
Chemical spills	<p>Chemical spills must be quickly contained and properly cleaned up.</p> <p>Refer to the chemical label for any specific clean-up instructions.</p> <p><u>General procedures include:</u></p> <ol style="list-style-type: none"> 1. Controlling the spill by stopping the source of the spill. 2. Containing the spill so that it does not spread and get into water sources. 3. Cleaning up the spill immediately. 4. Seeking additional advice from: - <u>Chemical manufacturer</u>. See chemical label for contact information.

----- DURING STORAGE / TROUBLESHOOTING -----

- **PREPARE THE SPRAYER FOR STORAGE** according to the instructions in this manual.
- **SELECT** a well-ventilated **STORAGE AREA** away from sources of heat, flame, or sparks. Gasoline vapors can ignite and cause a fire.
- **READ and FOLLOW** the safety rules for troubleshooting / servicing the sprayer to avoid accidental exposure to chemical and risk of electric shock.

Warning Label Location

⚠ WARNING ⚠

THIS SPRAYING SYSTEM CONTAINS SOME RV ANTIFREEZE FOR PROTECTION DURING SHIPPING AND STORAGE. RV ANTIFREEZE IS 100% SAFE, NON-TOXIC, AND BIODEGRADABLE.

- CHECK TO MAKE SURE ALL FITTING AND HOSE CONNECTIONS ARE TIGHT BEFORE USE.
- PERFORM A FULL PRESSURE RUN TEST WITH WATER ONLY, AS INSTRUCTED BY THE MANUAL.
- CHECK FOR LEAKS, AND COMPLETELY FLUSH THE SYSTEM BEFORE USING ANY CHEMICALS.

32362

CAUTION

Rinse/Flush Unit
Sprayer life will be shortened if these rules are not followed:

- Flush the unit with clean water after each use to clean the chemicals out of the pump, hoses, and spray gun.
- Rinse sprayer off after each use. Corrosive chemicals will shorten the life of the unit if it is not rinsed off.

Irons NORTH STAR TOOL & EQUIPMENT CO. 1-800-270-2610 Part No. 779260

⚠ WARNING

DO NOT spray undiluted bleach. Always dilute strictly in accordance with the directions. **CONSULT** chemical label for correct ratios. Never mix bleach solutions stronger than 1800ppm. Incorrect ratios could release harmful gases.

DO NOT use for any other purpose once the sprayer has been used with bleach. **DO NOT** mix bleach with other chemicals.

KEEP bleach out of reach children. Bleach is a skin and eye irritant.

KNOW emergency procedures **BEFORE** handling chemicals. Sprayer leaks, bodily chemical contact, poisoning, and spills are all situations which require immediate response.

Improper use of the sprayer or handling of chemicals could result in serious injury or illness to the operator or nearby persons/animals, or could cause damage to the environment.

Replace this label if damaged or destroyed. Consult Owner's Manual for ordering instructions.

PN 802168

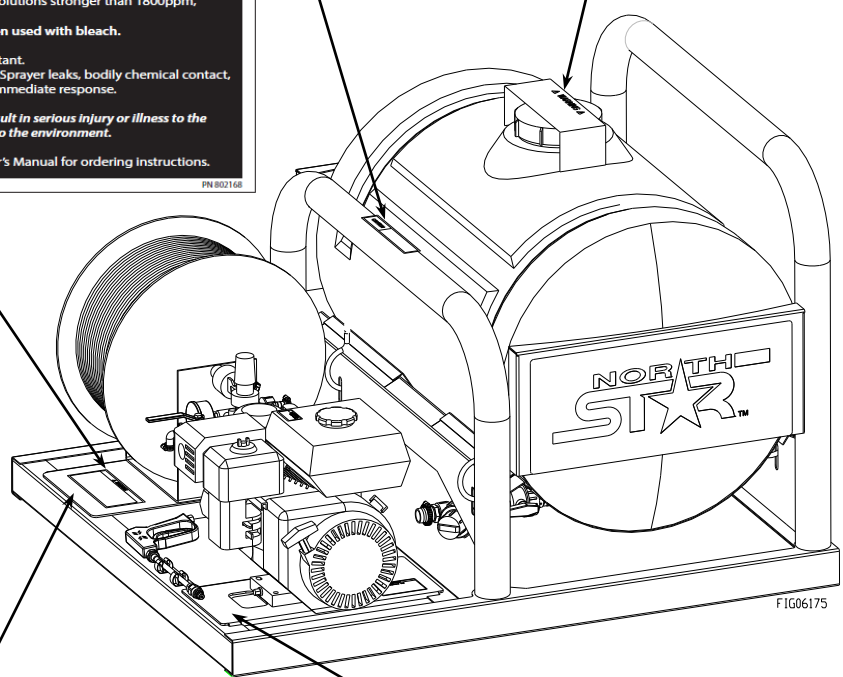

⚠ WARNING

READ and **UNDERSTAND** the Owner's Manual completely before using this sprayer. Assemble, test, and use only in accordance with the Owner's Manual instructions.

READ and **FOLLOW** chemical label instructions. Bleach is a hazardous chemical which must be handled carefully.

ALWAYS wear personal protective equipment as directed by the chemical manufacturer's label.

AVOID inhaling, ingesting, or coming into direct contact with any chemicals

EXERCISE CAUTION in vehicle handling. Vehicle will be less stable and handle very differently with filled sprayer attached.

DO NOT TURN ON power to sprayer until ready to spray in order to avoid inadvertent spray release.

Replace this label if damaged or destroyed. Consult Owner's Manual for ordering instructions.

PN 802169

⚠ WARNING

POISONOUS GAS

This product's use gives off carbon monoxide, an odorless gas that can kill you.

- **ONLY** use outdoors and away from air intakes.
- **NEVER** use inside homes, garages or sheds. **EVEN IF** you run a fan or open doors and windows.

See product manual for more details.

PN 39259

Part#	Description
32362	Decal, Antifreeze
779260	Decal, Rinse/Flush
802168	Decal, Bleach Warning
802169	Decal, Sprayer Warning
39259	Decal, Carbon Monoxide

Always make sure safety labels are in place and in good condition. If a safety label is missing or not legible, order new labels or unsafe operation could result.

To order replacement safety labels, call Irontron Product Support at 1-877-234-6869.

Unpacking

Closely inspect all contents in the shipping carton.

Note that some parts are shipped inside the tank.

- If you have missing or damaged components, please contact NorthStar Product Support at 1-800-270-0810.

The following items are found in the manual bag.

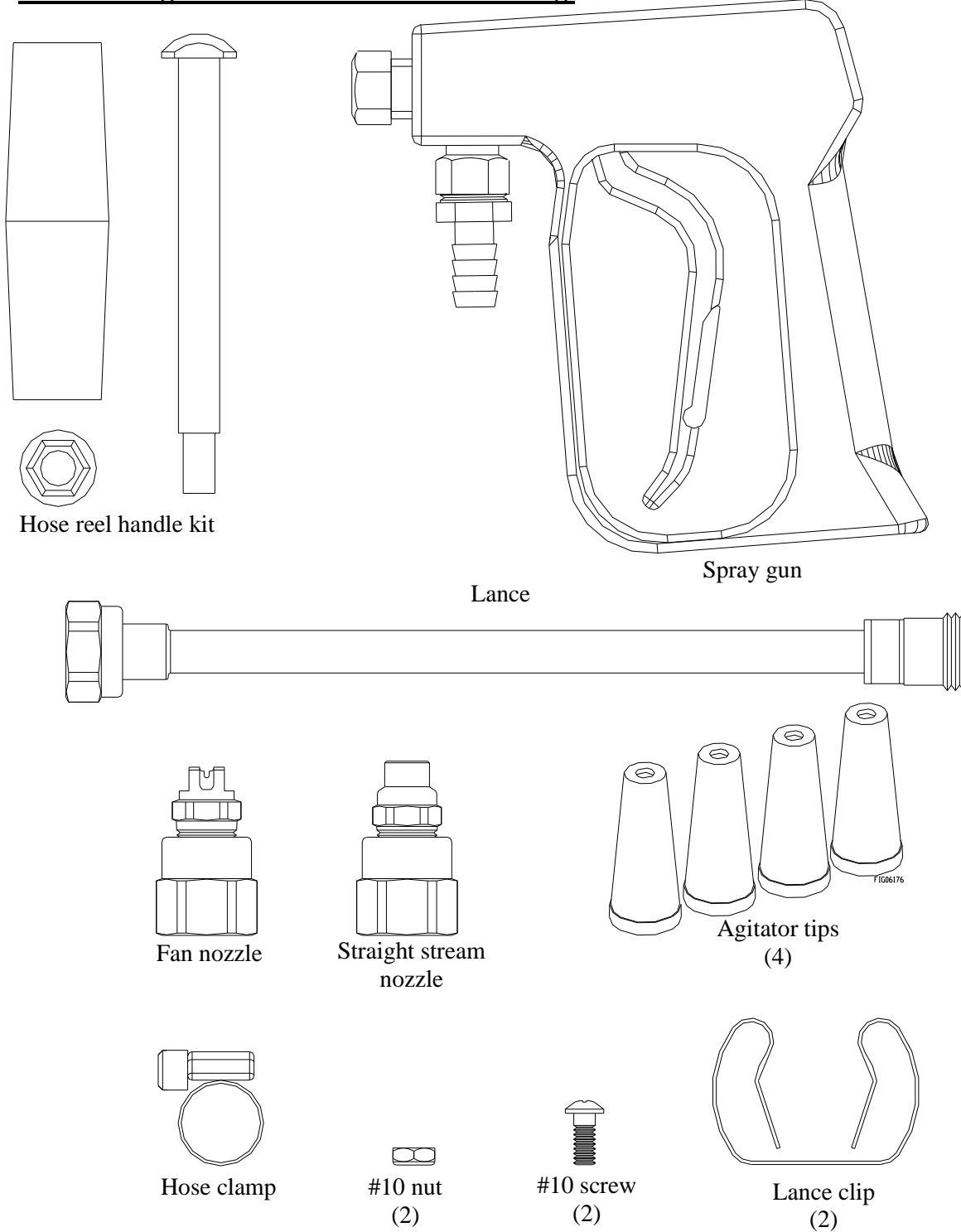

Assembly

Step One: Attach hose reel handle to the hose reel.

Attach the hose reel handle to the hose reel with the handle bolt and handle nut.

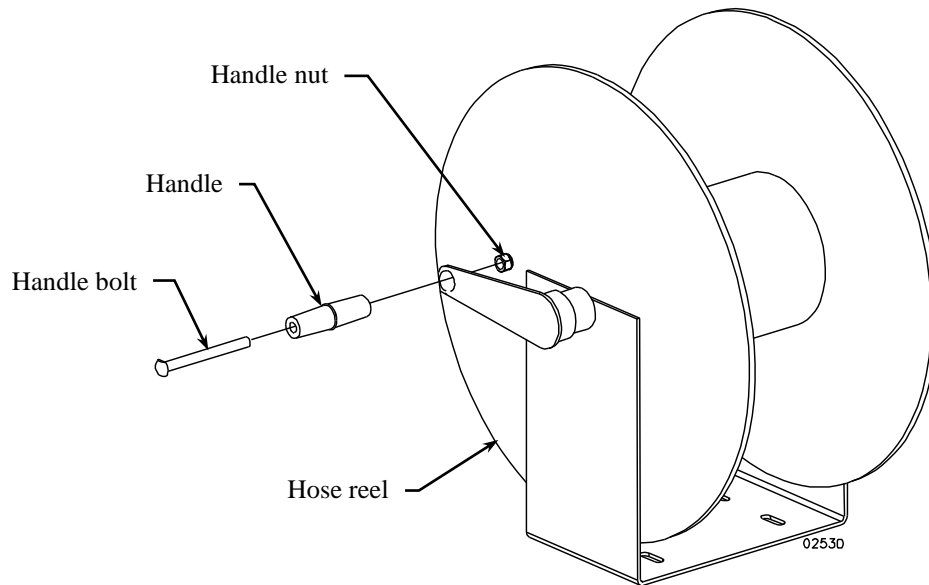

Step Two: Install lance clips.

Use (2) #10 screws and (2) #10 nuts to fasten the lance clips to the frame.

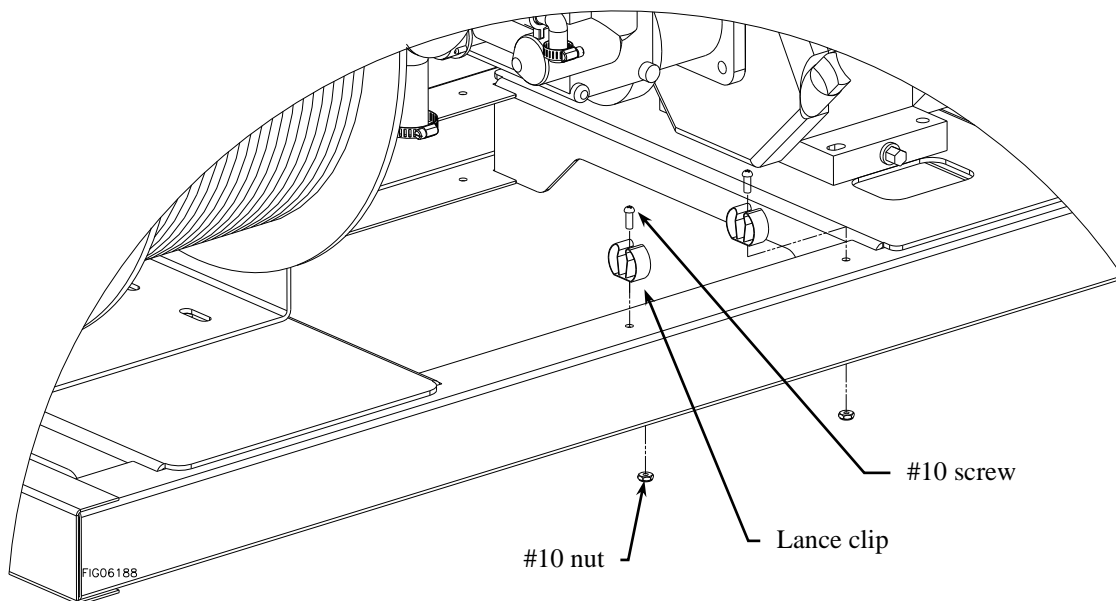

Assembly

Step Three: Attach lance extension and/or nozzle to spray gun.

Note: The spray gun can be operated with or without the lance.

To operate without the lance:

1. Remove the thread protecting nut that is shipped on the outlet of the spray gun.
2. Thread nozzle onto spray gun outlet.

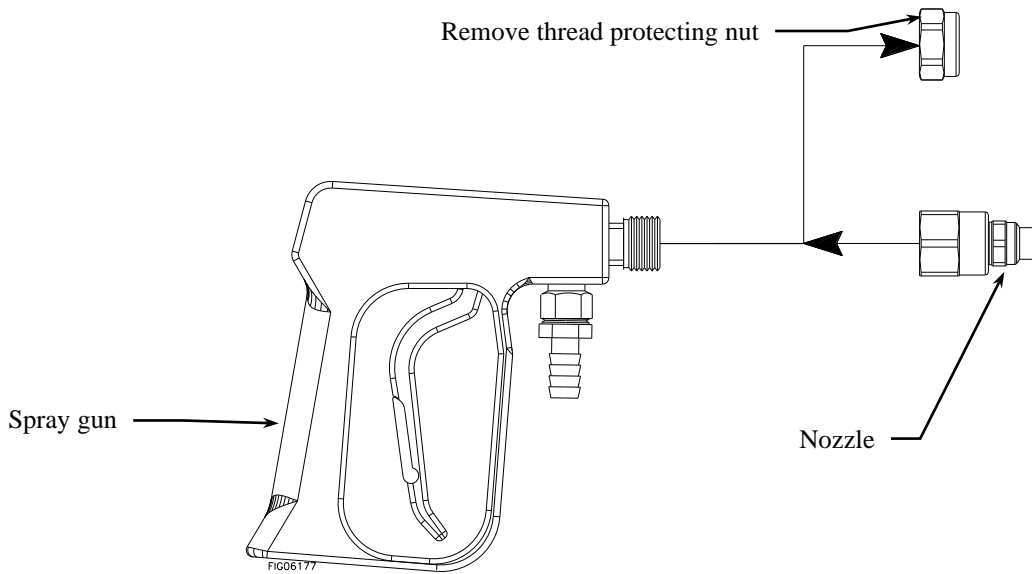

To operate with the lance:

1. Remove the thread protecting nut that is shipped on the outlet of the spray gun.
2. Thread lance onto spray gun outlet.
3. Thread nozzle onto end of lance

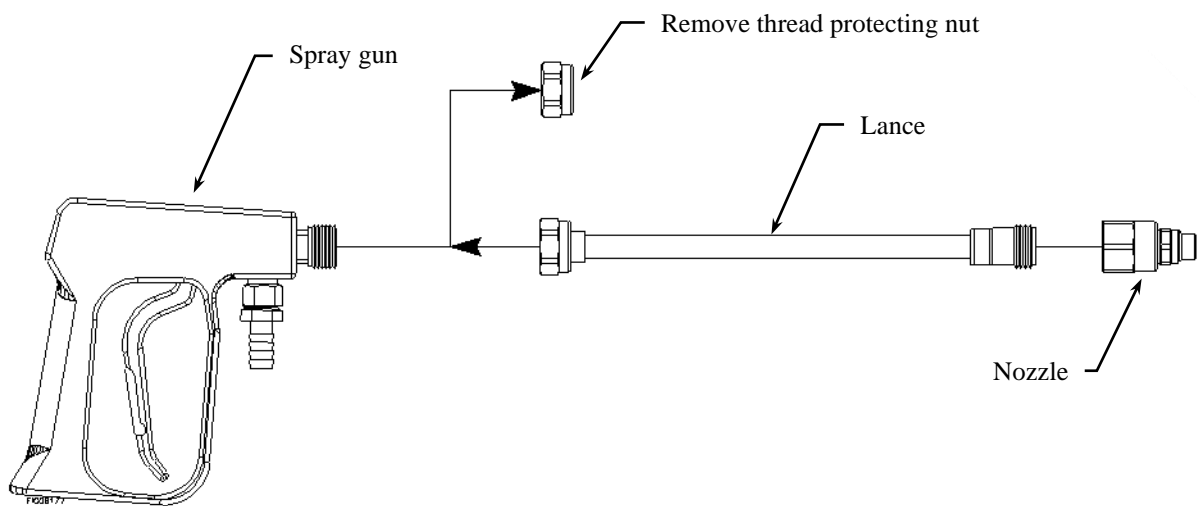

Assembly

Step Four: Attach spray gun to hose.

Connect the hose from the hose reel to the spray gun by following the hose clamp installation instructions.

Hose clamp installation instructions:

- i) Slide hose clamp over the end of the hose.
- ii) Push the hose onto the hose barb.
- iii) Slide the hose clamp over the hose barb.
- iv) Tighten the hose clamp

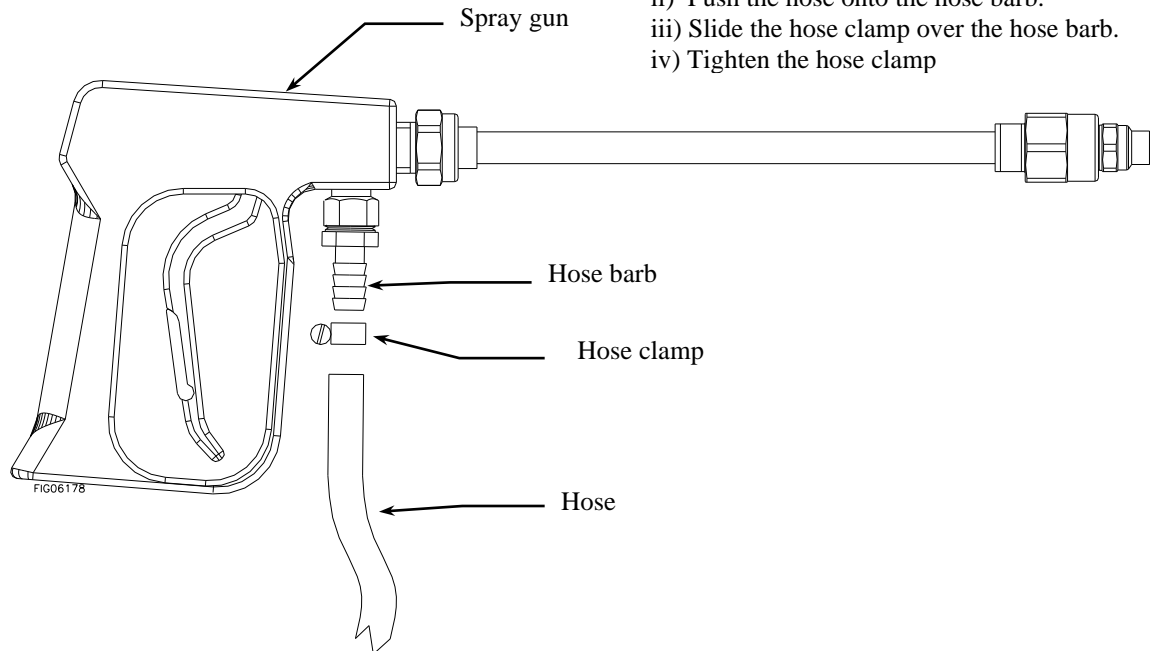

Step Five: Attach the sprayer to the vehicle

Secure the sprayer to the vehicle to prevent the sprayer from shifting during transport.

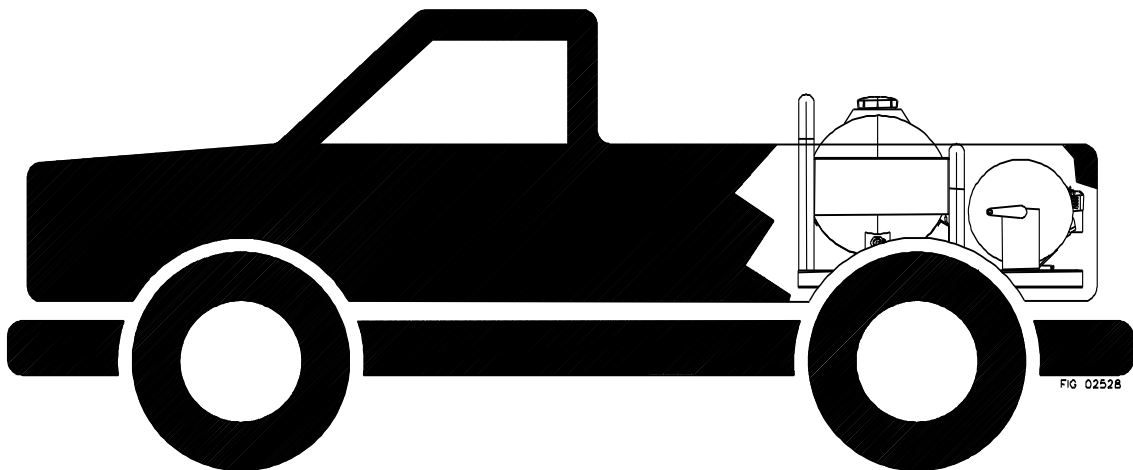

Assembly

Step Six: Check and test completed assembly

⚠ WARNING

Check and test completed assembly

Serious injury could result from chemical leaks if sprayer is improperly assembled or the design of the sprayer is modified.

Follow the steps below to ensure the sprayer is properly assembled. Never modify the sprayer's design.

1. Check assembly	Check assembly to make sure the sprayer is properly assembled and in safe working condition: a) Check that the gun clip screws are tight, hose clamps are secure, and tank straps are properly fastened. b) While it is unlikely that factory assembled components become loose, they should also be checked to make sure they are tight.
2. Fill tank with water	Test the system for leaks with water: a) First read the instructions in this Owner's Manual for Operation of the sprayer. b) Add fuel to the engine per the instructions in this manual. c) Fill the tank with water per the instructions in this manual. <u>Important:</u> The sprayer should NOT be running when you fill the tank. d) Check for leaks throughout the system by operating the sprayer per the instructions in this manual: i) Turn the sprayer ON. (See Operation Instructions) ii) With the agitation valve closed and the spray gun trigger released, adjust the pressure through its full range – to maximum and back. (See Operation Instructions) iii) Open the agitation valve to initiate agitation. (See Operation Instructions) iv) Operate the spray gun. (See Operation Instructions) e) If a leak is detected, <u>fix the leak and re-test the system with water.</u>

Machine Components

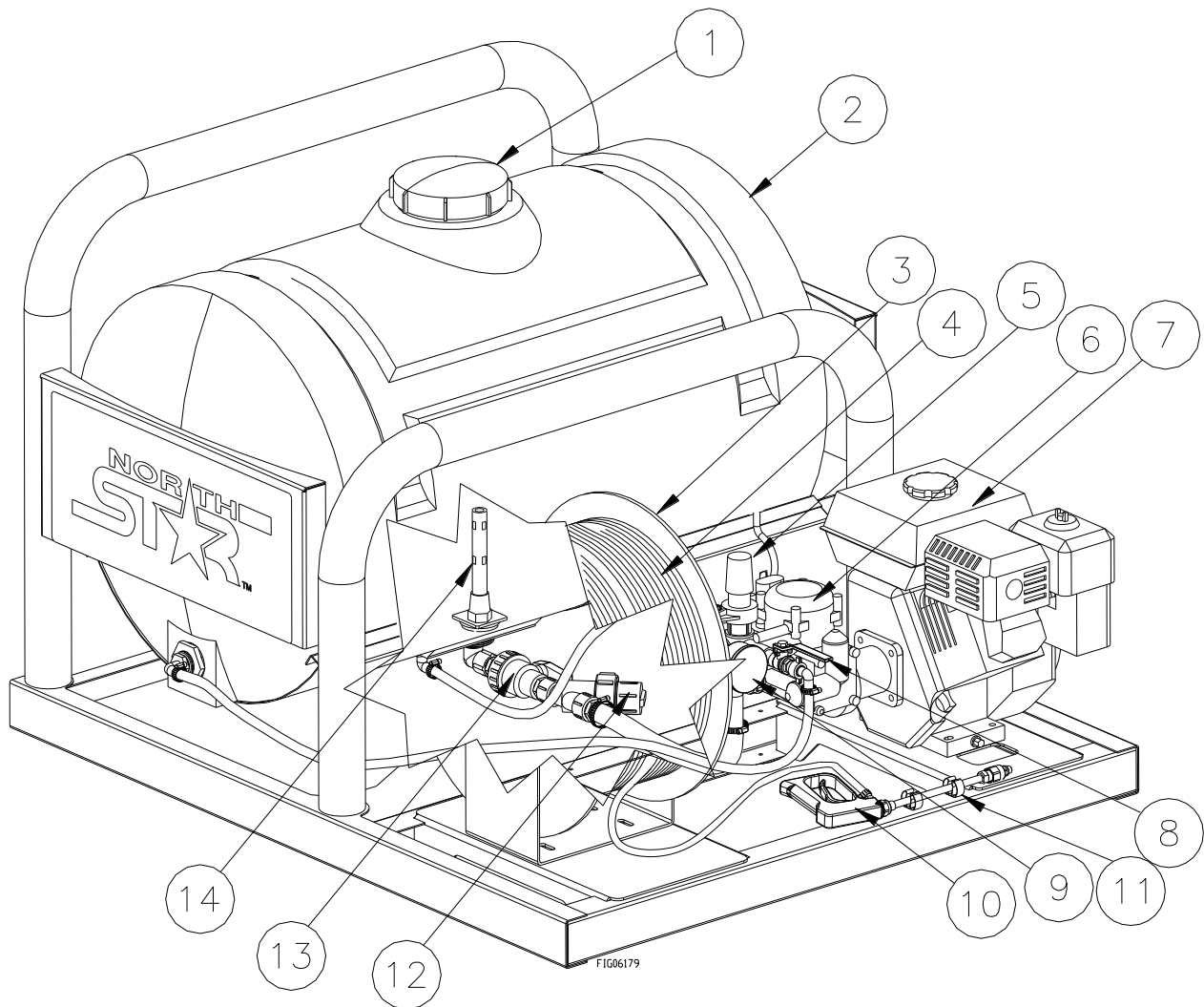

1. **Fill Cap:** The fill cap is vented to allow air to enter the tank as the chemical is used but doesn't allow chemical to escape the tank.
2. **Sprayer Tank:** The sprayer tank holds the chemical.
3. **Hose Reel:** The hose reel is the storage location for the gun hose.
4. **Gun Hose:** The gun hose transfers the chemical from the sprayer to the spray gun.
5. **Pressure Regulator:** Turn the pressure regulator until the sprayer is running at the desired pressure. Do not exceed 350PSI.
6. **Pump:** The pump produces the chemical flow.
7. **Engine:** The air-cooled engine powers the pump.
8. **Agitation Valve:** Open valve for agitation. Close valve to send all flow to the spray gun.
9. **Pressure Gauge:** The gauge is an indicator of the system pressure
10. **Spray Gun:** Use the spray gun to apply chemical to specific areas.
11. **Gun Clips:** Use the gun clips to store the spray gun.
12. **Suction Strainer:** The strainer prevents debris from entering the pump. It also serves as the tank drain.
13. **Ball Valve:** The ball valve allows strainer filter removal without draining the sprayer tank.
14. **Agitator:** The agitator creates a turbulent flow in the tank and keeps chemicals well mixed.

Operation – Important Safety Information

Now that you have completed and tested your assembly, there is some important safety and health information you need to know with regard to handling and spraying chemicals, as well as vehicle handling with the sprayer attached.

WARNING

Carefully read and make sure you understand the following safety information before using the sprayer.

General Chemical Safety:

WARNING

- Heed the warnings below and follow all instructions carefully.
- Improper handling of chemicals can result in serious injury or illness, or cause damage to the environment.

- **Chemical label.** ALWAYS READ and FOLLOW all chemical label instructions.
- **Licensing/regulation.** Refer to any applicable licensing restrictions or state/federal regulations with regard to the application of the particular chemical you plan to use.
- **Emergency procedures.** Before handling chemicals, carefully review the “Chemical Accident Procedures” listed later in this section, as well as the “Statement of Practical Treatment” on the chemical label.
- **Inhalation/contact.** ALWAYS take precautions to avoid inhaling or coming into contact with the chemical.
- **Personal protective equipment.** ALWAYS wear protective clothing, eye protection, and chemical-resistant gloves when filling, using and cleaning the sprayer. Wear additional protective gear (such as facemask or apron) as recommended on the chemical label.
- **Children/pets.** ALWAYS exercise extra caution around children. Keep sprayer and all spray materials away from children and animals.
- **Ventilation.** ALWAYS ensure there is adequate ventilation when mixing, pouring, or spraying.
- **Flammables.** NEVER use any flammable chemicals in the sprayer.
- **Chemical interaction.** DO NOT use the sprayer with other chemicals once it has been used with bleach. Different chemicals may interact dangerously with each other.
- **Chemical storage.** ALWAYS store chemicals in a properly labeled container and in a secure location per the manufacturer’s recommendations.
- **Health monitoring.** Monitor the health of operators who are frequently exposed to chemicals, as recommended by the chemical label or local/federal regulations.

Operation – Important Safety Information

Chemical Application Safety:

WARNING

- Caution must be used when spraying chemicals to avoid unsafe exposure to humans and the environment.
- Heed the warnings below and follow all instructions carefully.

Before Spraying

- **Sprayer prep.** ALWAYS inspect and prepare the sprayer before use according to the directions provided in this manual.
- **Fueling.** Follow instructions in this manual for safely fueling the engine. Gasoline is flammable and can explode. Always use caution when handling gasoline.
- **Keep sprayer off.** Do not turn on power to the sprayer until ready to spray in order to avoid unintentional spray release.
- **Wind speed.** NEVER spray when wind speed exceeds 4 MPH in order to minimize spray drift.
- **Clear area/post.** ALWAYS keep the work area clear of people and pets. POST warning notices to restrict access by the public for the period recommended on chemical label.
- **Operator age.** You must be 16 years of age or older to operate this sprayer.

During Spraying

- **Over application.** DO NOT over apply chemical. Apply at a rate recommended by chemical manufacturer. Excess can be dangerous to humans, damage desirable plants, and contaminate soil and water sources.
- **Never point gun.** NEVER point the spray gun at people or animals.
- **Use firm grip.** ALWAYS hold the spray gun with a firm grip when using it to spray at higher pressures in order to prevent gun from whipping. Keep good footing and balance at all times.
- **Children/pets.** ALWAYS exercise extra caution when spraying near areas accessible to children and pets.
- **Eating/smoking.** DO NOT eat, drink, smoke, rub your eyes, or touch any part of your bare skin while handling chemicals and spraying.
- **Heat/flames.** DO NOT spray near open flames or sources of heat.
- **Spills.** ALWAYS clean up spills immediately per instruction on the chemical label.
- **Unattended.** ALWAYS turn off vehicle and set brake or block wheels, turn off power to sprayer, and relieve system pressure before leaving sprayer unattended.
- **Troubleshooting.** ALWAYS refer to the safety instruction in the Troubleshooting Section before attempting any repairs.

After Spraying

- **Clean sprayer.** ALWAYS clean the sprayer immediately after use according to the directions provided in this manual.
- **Decontaminate.** ALWAYS decontaminate yourself immediately after you are finished spraying and handling chemicals. Wash all exposed areas of the body with soap and water and remove and launder clothing.
- **Chemical disposal/storage.** ALWAYS dispose of or store remaining chemicals properly as recommended on the chemical label.

Operation – Important Safety Information

Transporting Safety:

⚠ WARNING

Serious injury can occur if the vehicle on which the sprayer is mounted is driven unsafely.

- **Read vehicle instructions.** Review safety instructions in your vehicle manual with regard to carrying heavy cargo loads.
- **Driver age.** You must be 16 years of age or older to drive the vehicle with the filled sprayer attached.
- **Vehicle handling.** Be aware that vehicle handling will be affected when driving with the filled sprayer. Exercise caution to avoid loss of control or rollover:
 - **Keep speed to a minimum** so you can maintain control at all times. Reduce speed prior to turns.
 - **Allow for more distance to stop.**
 - **Avoid any sudden** steering maneuvers, starts, or stops that could create liquid sloshing in the sprayer and instability.
- **Rough or sloped terrain.** Slow down and exercise extra caution on rough or sloped terrain in order to reduce risk of rollover. Pick the most level route possible when transporting across fields. Drive up and down slopes that cannot be avoided, rather than across. Use a vehicle equipped with a Roll Over Protection System (ROPS) if you will be operating on non-level terrain.
- **Reduced visibility.** Be aware that visibility may be reduced with sprayer attached. Be extra cautious when backing up or turning.
- **Ride / transport.** Never ride or transport cargo on the sprayer.
- **Under the influence.** Never transport or operate this sprayer while under the influence of alcohol, drugs, or medication
- **Unattended.** Before leaving the sprayer unattended, turn off both the vehicle and sprayer, and set vehicle brakes.

Chemical accident procedures:

⚠ WARNING

Before you fill the sprayer, review the following information with regard to handling accidents. Chemical spills, sprayer leaks, personal contamination, and poisoning are accident situations which you may encounter. All require an immediate response – See instructions below.

Sprayer leak	<p>In the event that the sprayer develops a leak while spraying chemicals, you must <i>immediately stop spraying.</i></p> <p style="padding-left: 20px;">Turn off the sprayer and follow the directions below, as applicable.</p>
Bodily chemical contact	<p>Personal contamination can occur when chemicals splash, spill, or spray directly onto a person.</p> <p>1. Follow the emergency first aid instructions on the chemical label listed in the “First Aid” or “Statements of Practical Treatment” section.</p> <p><u>General procedures include:</u></p> <p>a) Eyes – immediately flush with water or follow other directions as specified on the chemical label.</p> <p>b) Skin – immediately wash all contaminated skin surfaces with soap and water, or follow directions as specified on the chemical label.</p> <p>c) Clothing – remove contaminated clothing immediately. Dispose of heavily contaminated clothing per the instructions on the chemical label for safe chemical/container disposal.</p>

Operation – Important Safety Information

	<ol style="list-style-type: none"> 2. Seek medical advice if instructed on the label, or if the victim experiences symptoms of harmful effects such as burning, swelling, nausea, chest pain, difficulty breathing, dizziness or confusion. When seeking medical advice, be sure to bring the chemical product label.
<p>Poisoning by ingestion or inhalation</p>	<p>In case of poisoning from ingestion or inhalation:</p> <p>IF THE VICTIM HAS COLLAPSED OR IS NOT BREATHING, <u>CALL 911</u>.</p> <p>Otherwise:</p> <ol style="list-style-type: none"> 1. If you are the victim, immediately seek assistance from nearby personnel because you may become incapacitated. 2. Follow the emergency first aid instructions on the chemical label in the “First Aid” or “Statement of Practical Treatment” section. 3. Call a poison control center for further advice. In the U.S., call 1-800-222-1222 to be automatically linked to the nearest certified poison control center. Have the chemical label available for reference.
<p>Chemical spills</p>	<p>Chemical spills must be quickly contained and properly cleaned up.</p> <p>Refer to the chemical label for any specific clean-up instructions with regard to the chemical spilled.</p> <p><u>General procedures include:</u></p> <ol style="list-style-type: none"> 1. Control the spill by stopping the source of the spill. If the source of the spill is a container leak, place the leaking container in a larger, watertight container. Keep unprotected people away from the spill site. 2. Contain the spill so that it does not spread and get into water sources. Use a shovel or other tool to make a dike around the spill with soil, sod, or absorbent material. 3. Clean up the spill immediately -- Absorbent materials like ground corncobs or pet litter should be spread on the spill area to soak up the chemical. The contaminated material should then be shoveled into a leak proof container. Do not flush the spill area with water until you receive advice as directed below. 4. Seek additional advice from the chemical manufacturer and your state’s regulatory agency regarding decontamination of the spill site: <ul style="list-style-type: none"> - <i>Chemical manufacturer.</i> The chemical label provides contact information for the chemical manufacturer.

Operation – Preparing the Sprayer for Each Use

Step One: Inspect/Repair

If the sprayer has been used previously, it must be prepared BEFORE EACH SUBSEQUENT USE.

⚠ WARNING

- Read instructions below carefully for inspecting and preparing the sprayer.
- Damaged or clogged equipment could result in leaks or uncontrolled spray.
- Leaks could result in injury to the operator or bystanders from chemical exposure, or cause damage to the environment.

Important safety rules:

- **Power off.** Make sure all power is OFF before cleaning, inspecting, or servicing the sprayer.
- **Guards / shields.** Make sure all guards and shields are replaced after servicing the sprayer.
- **Replacement parts.** If a part needs replacement, only use parts that meet the manufacturer’s specifications. Replacement parts that do not meet specifications may result in a safety hazard or poor operation of the sprayer.

1. Ensure sprayer attached	Ensure the sprayer is securely attached to vehicle.
2. Ensure tank empty	Ensure no other chemical other than bleach has been used in the sprayer.

3. Clean suction strainer

Clean the suction strainer of any chemical residue.
 It is important to clean the suction strainer before each use to ensure it is not clogged and to prevent residual chemical from contaminating sprayer contents

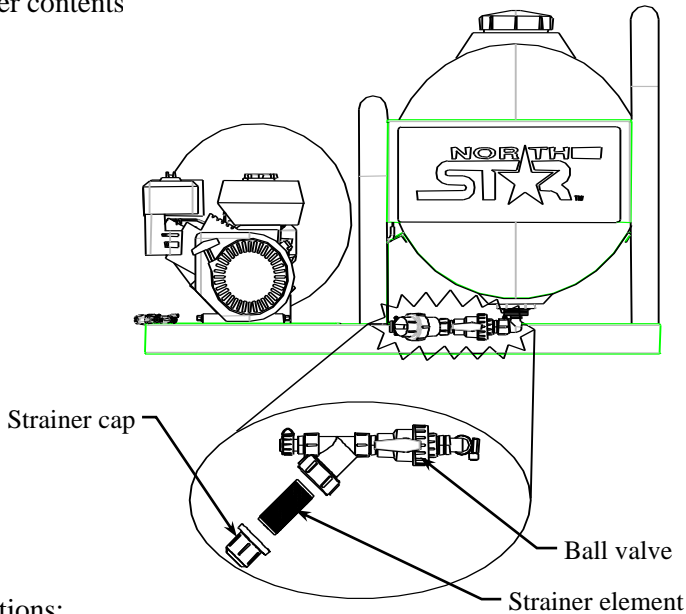

Directions:

- a) Close the ball valve.
- b) USING CHEMICAL RESISTANT GLOVES, unscrew the strainer cap and remove the strainer element.
- c) Run the strainer element under fresh water to remove debris.
- d) Replace the strainer element and reinstall the strainer cap.
- e) Open the ball valve.

NOTE: It is not unusual for the operator to be exposed to chemical residue while cleaning the strainer—wear chemical resistant gloves.

Operation – Preparing the Sprayer for Each Use

4. Inspect & repair

Inspect and test the sprayer thoroughly

- a. Inspect hoses for exposed mesh and holes. Replace all worn or damaged hoses.
- b. Inspect fittings for cracks and leaks. Replace all damaged fittings with original NorthStar parts.
- c. Inspect tank for cracks.
- d. Check to be sure all nuts, bolts, and screws are tight.
- e. Ensure tank straps are snug.
- f. Check oil levels in pump and gearbox. See pump owner's manual.
- g. Check oil level in engine. See engine owner's manual.
- h. Check for fuel leaks. Any fuel leak is a fire hazard. Fix any fuel leaks before starting engine.
- i. Partially fill tank with plain water and spray to test for leaks. Repair as needed.

IMPORTANT: After any repair work has been done, ALWAYS test for leaks with water one final time before using.

Operation – Preparing the Sprayer for Each Use

Step Two: Fueling

⚠ WARNING

Gasoline is highly flammable and explosive. You can be burned or seriously injured when handling fuel. Use extreme care when handling gasoline.

1. Engine off / cool	<p>The engine must be off and allowed to cool at least two minutes before adding fuel.</p> <p>WARNING: A running engine is hot enough to ignite fuel. Never add fuel or remove gas cap if engine is running or still hot.</p>
2. Outdoor location	<p>Fill fuel tank outdoors – never indoors.</p> <p>WARNING: Gasoline vapors can ignite if they collect inside an enclosure. Explosion can result.</p>
3. Remove gas cap	<p>Remove engine gas cap.</p>
4. Add gasoline	<p>Add gasoline through fill opening from a UL-approved container.</p> <p><u>Important Safety Instructions:</u></p> <ul style="list-style-type: none"> • Use approved container. NEVER pump fuel directly into engine at gas station. Static charge can build and ignite fuel. Use a UL approved fuel container to transfer gas to the engine. • Don't overfill. DO NOT overfill the gas tank. Allow at least 1/2" of empty space below the fill neck to allow for fuel expansion • Heat / flames / sparks. Stay away from sources of heat, flame, or sparks while adding fuel. <div style="text-align: right; margin-top: 10px;">  </div>
5. Spills / splashes	<p>Clean up fuel spills /splashes immediately.</p> <p>Move sprayer away from spilled fuel on the ground.</p> <ol style="list-style-type: none"> 1. Wipe fuel off engine and wait 5 minutes for excess fuel to evaporate before starting engine. 2. Gas soaked rags are flammable and should be disposed of properly. 3. If gasoline is spilled on your skin or clothes, change clothes and wash skin immediately. 4. If gasoline is spilled on your skin or clothes, change clothes and wash skin immediately.
6. Replace gas cap	<p>Replace gas cap securely before starting engine.</p>
7. Gasoline storage	<p>Store gasoline in a cool, dry place in a UL approved, tightly sealed container.</p>

Operation – Using the Sprayer

Step One: Assess wind conditions and clear work area.

Before you decide to spray, you must determine whether wind conditions are suitable. You must also restrict access to the work area to ensure the safety of bystanders.

⚠ WARNING

Do not spray if wind speeds are greater than 4 MPH or if there are bystanders in the intended spray area.

1. Assess wind speed	<p>Assess weather conditions to ensure that it is not too windy to spray.</p> <p>DO NOT SPRAY if wind speeds are greater than 4 MPH.</p> <p><i>Visible indication of wind speed:</i> If leaves are in constant motion or there is any branch movement, DO NOT spray because the wind is too strong.</p>
2. Clear work area	<p>Clear the work area of all bystanders and pets.</p> <p>Restrict access by the public for the period recommended on chemical label.</p>

Step Two: Check and set accumulator pressure.

Using an air pressure gauge, check the pressure in the accumulator. The accumulator dampens water pulsations created by the pump's diaphragms. This provides smoother water delivery to the nozzle. The accumulator's pressure must be adjusted according to the operating pressure. See table below.

Pump Operating Pressure	Accumulator Inflating Pressure
PSI	PSI
29-73	29
73-145	29-73
145-363	73-102

Locate the pressure valve on the accumulator, and:

1. Check the pressure in the accumulator with an air pressure gauge.
2. Add or remove air and recheck with air pressure gauge to achieve correct pressure.

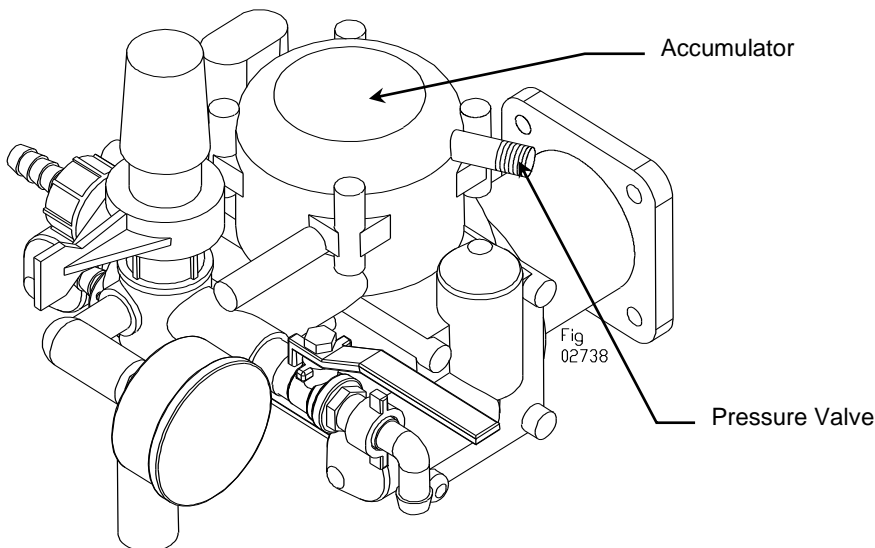

Operation – Using the Sprayer

Step Three: Fill the sprayer.

⚠ WARNING

- ALWAYS wear personal protective equipment as directed on the chemical label when handling chemicals.
- Long pants and sleeves, chemical resistant gloves, and eye protection are strongly recommended. Additional protective gear may be required.

Fill the sprayer using the following steps:

1. Review safety information	Review the “Operation – Important Safety Information” related to <u>General Chemical Safety</u> and <u>Chemical Accident Procedures</u> provided in this manual.
2. Choose safe mixing/loading area	Choose a safe chemical mixing and loading area. - Choose an outdoor, well-ventilated area away from unprotected people, animals, food, and other items that might become contaminated.
3. Wear personal protective equipment	Wear personal protective equipment as directed on the chemical label. - Note that additional equipment may be specified for mixing and loading activities.
4. Turn off sprayer and vehicle	Turn OFF the sprayer before filling. - The vehicle should also be off, with brake set or wheels blocked to prevent unintended movement.
5. Remove fill cap	Remove the fill cap located on top of the sprayer.
6. Ensure tank flushed	Ensure tank is flushed of all chemicals from prior uses. - Residue chemicals are a health hazard. - To flush the tank the strainer cap must be removed, and the suction line ball valve has to be opened.
7. Check strainer cap	Ensure strainer cap is securely fastened.

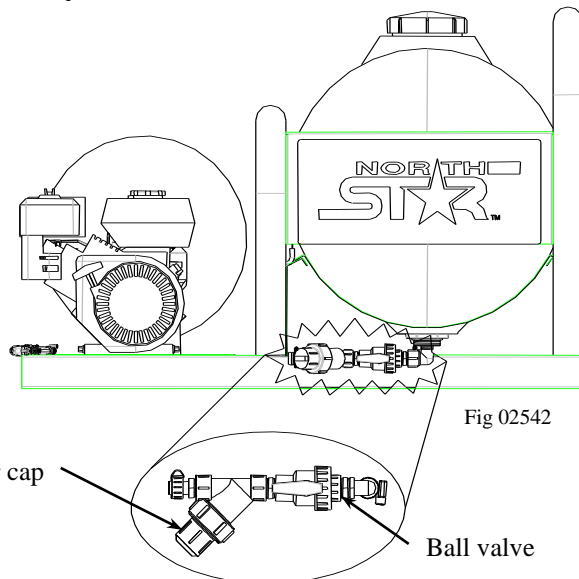

Fig 02542

Operation – Using the Sprayer

8. Fill tank

Add chemical to tank through fill cap:

- a) Confirm the chemical/water dilution ratios specified on the chemical label. The sprayer is rated for disinfecting bleach concentrations up to 1800ppm.
- b) Determine chemical and water volumes needed for the planned application, taking into consideration that maximum tank capacity is 55 gallons.

Note: Only purchase and mix as much chemical as you need for the planned application in order to minimize chemical over application and the need for storing unused chemicals.

- c) Add chemical to the tank through the fill cap.

If the chemical is not pre-mixed, add water and chemical concentrate in the order prescribed on the label.

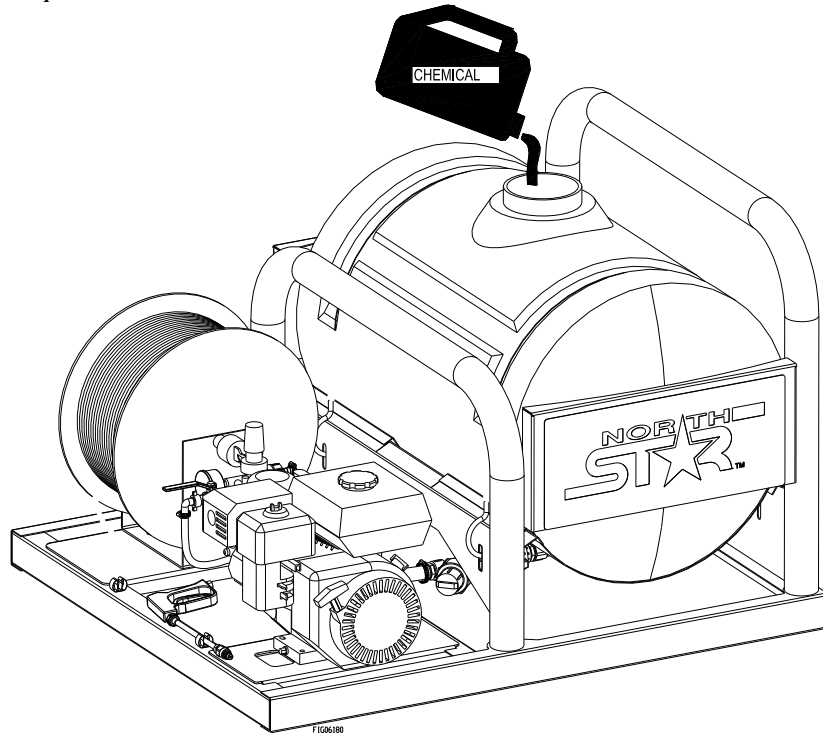

8. Ensure chemical mixed

Ensure chemical is thoroughly mixed in tank.

- Stirring device should be made of metal or plastic, non-chemical absorbing material, and then properly cleaned and stored after use.

9. Replace fill cap

Replace fill cap and tighten securely.

Operation – Using the Sprayer

Step Four: Operate the sprayer.

⚠ WARNING

- ALWAYS wear personal protective equipment as directed on the chemical label when spraying.
- Long pants and sleeves, chemical resistant gloves, and eye protection are strongly recommended. Additional protective gear may be required.

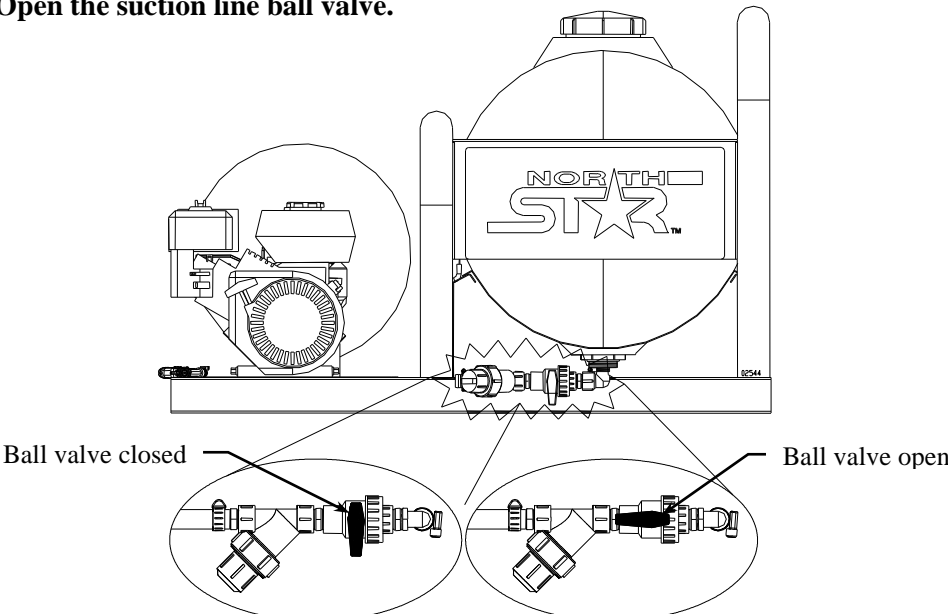
<p>1. Review safety information</p>	<p>Review the “Operation – Important Safety Information” related to <u>Chemical Application Safety</u> and <u>Transportation Safety</u> provided in this manual.</p>
<p>2. Wear personal protective equipment</p>	<p>Wear personal protective equipment as directed on the chemical label.</p>
<p>3. Engine operation precautions</p>	<p>Heed the following safety rules with regard to running the sprayer engine:</p> <ul style="list-style-type: none"> • Hot muffler. If you are starting a warm engine, stay clear of muffler. It may still be hot enough to burn you. • Hot exhaust. Hot exhaust fumes from engine can cause fire. Position muffler at least 7’ from combustible objects during operation. • Fire extinguisher. Have a Class B fire extinguisher available as a precautionary measure when operating the sprayer engine in dry areas. • Carbon monoxide. The running engine gives off carbon monoxide, a poisonous gas that can kill you. You CANNOT smell it, see it, or taste it. ONLY run the sprayer engine OUTDOORS and at least 20 feet from the home, away from windows, vents and air intakes, to allow proper ventilation. NEVER run sprayer engine inside homes, garages, sheds, or other semi-enclosed spaces. These spaces can trap poisonous gases, EVEN if you run a fan or open windows. If you start to feel sick, dizzy, or weak while using the sprayer, shut off the engine and get to fresh air RIGHT AWAY. See a doctor. You may have carbon monoxide poisoning.
<p>4. Open ball valve</p>	<p>Open the suction line ball valve.</p>  <p>The diagram shows a sprayer engine connected to a spherical tank labeled 'NORTH STAR'. A suction line connects the engine to the tank. Two callouts provide detailed views of the ball valve: 'Ball valve closed' shows the valve handle perpendicular to the line, and 'Ball valve open' shows the handle parallel to the line.</p>

Operation – Using the Sprayer

5. Rotate bypass lever to start

Rotate the bypass lever to the START position.

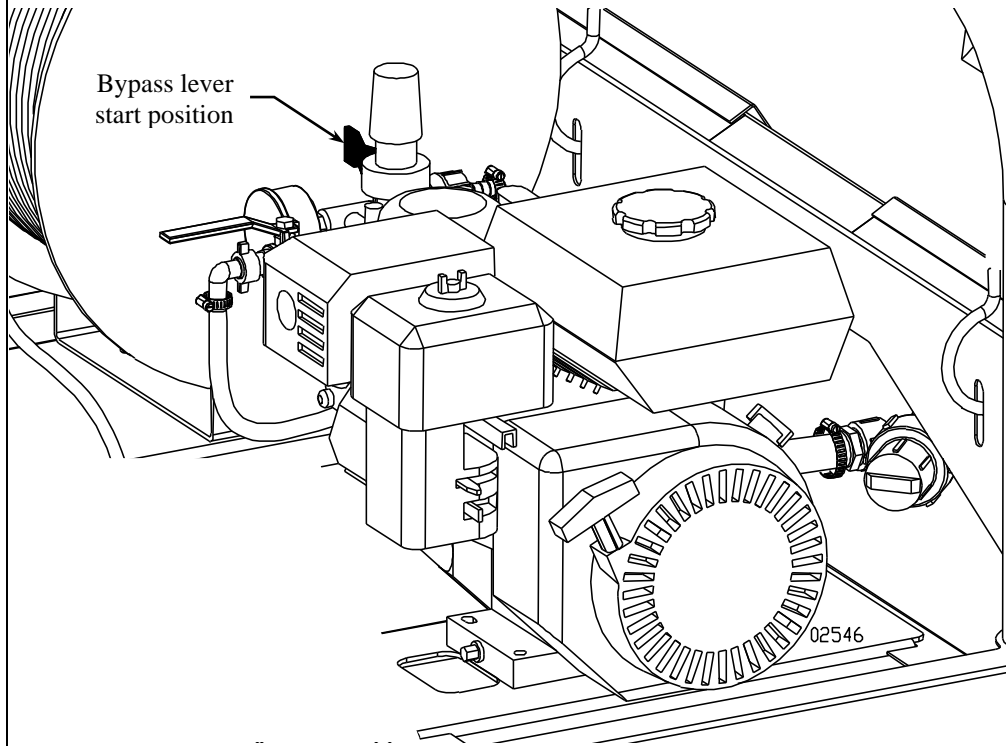

6. Start engine

Consult the engine Owner's Manual for starting the engine.

7. Rotate bypass lever to run

Rotate the bypass lever to the RUN position.

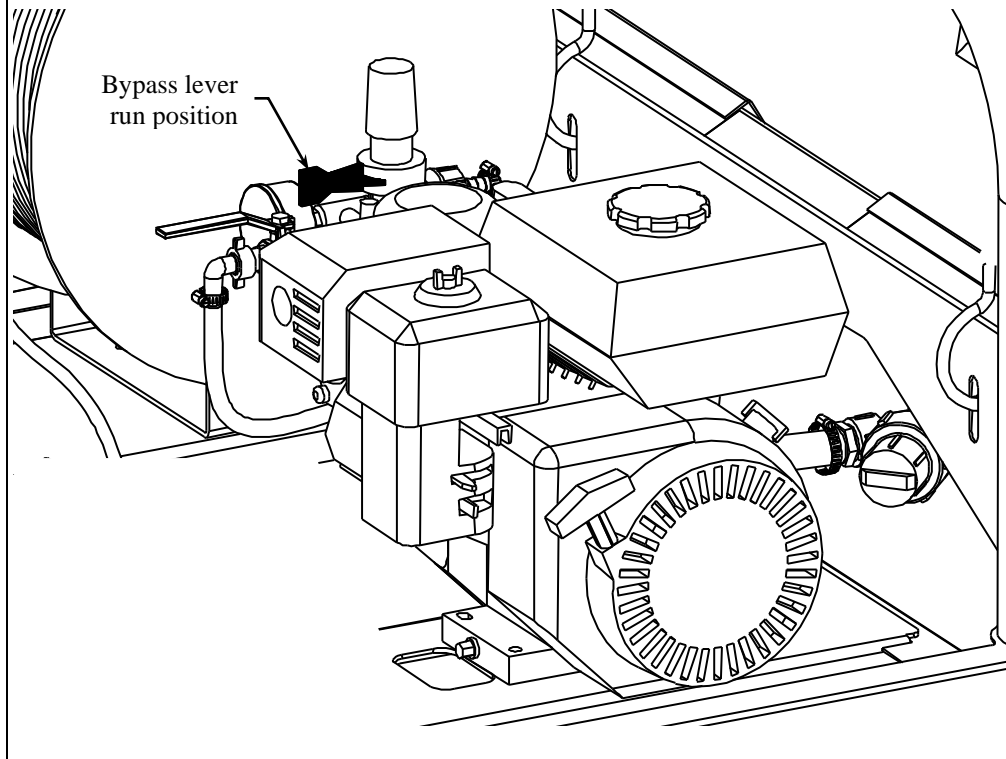

Operation – Using the Sprayer

8. Begin agitation if needed

1. Decide if agitation is required. Some formulations of liquid chemicals do not remain in solution and should be agitated to maintain a uniform mix.

This sprayer is equipped with an *agitator* that should be used when spraying chemicals classified as “flowable” (“F” or “L”), “wettable powder” (“WP” or “W”), “emulsion” (“EC” or “E”), “microencapsulated” (“M”), or water dispersible granules (“WDG” or “DF”). (See chemical label to determine its classification.)

2. Operation principle:

The nozzle design creates a venturi effect, speeding up the fluid flow as it exits the nozzle. This increase in velocity creates a low-pressure area (vacuum) which draws in additional fluid from the tank, multiplying the outlet flow for increased agitation.

3. Tuning the agitator

The four colored nozzles in the manual bag are used to tune your agitator. The following chart outlines the sizes of each tip. A higher inlet flow for a given tip will create a higher pressure in the agitator.

Orifice	Color
1/8”	Black
5/32”	Red
3/16”	Blue
1/4”	White

***Note:** With the 1/8 orifice tip you will have more pressure to the gun or broadcast nozzles and a less effective agitator. With the 1/4 orifice tip you will have less pressure to the gun or broadcast nozzles and a more effective agitator. Insert the tip that gives you the desired amount of pressure and agitation.

- a. Unscrew the agitator from the bulkhead fitting on the inside of the tank.
- b. Insert the desired nozzle as shown.
- c. Screw agitator back into the bulkhead fitting.

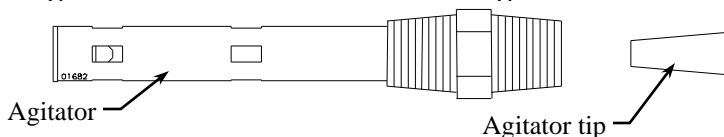

4. Operate the agitator

Begin agitation by opening the agitation valve.

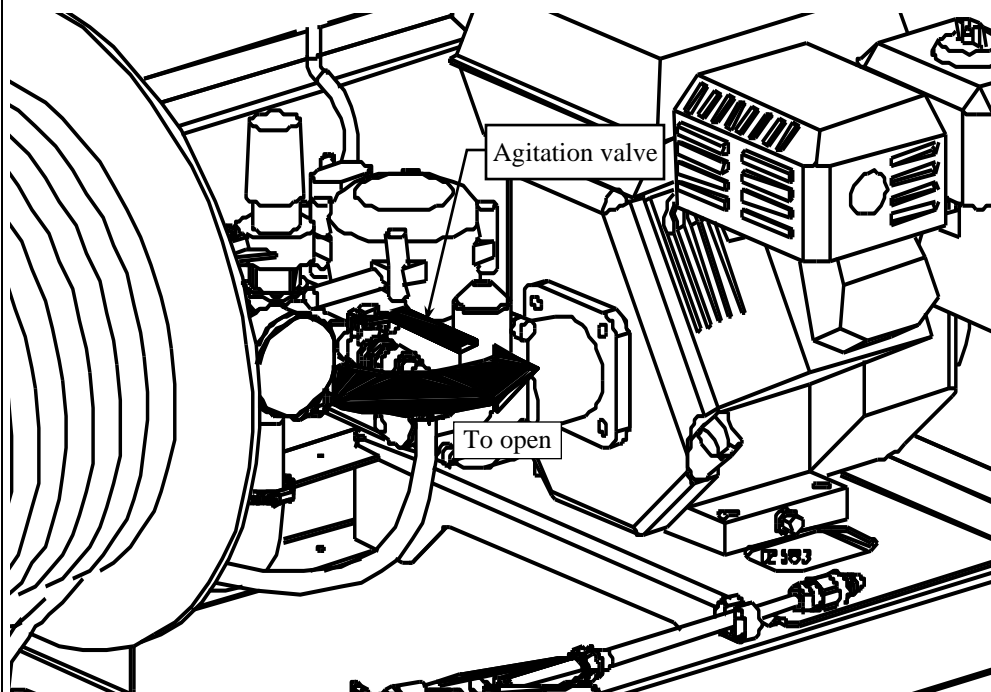

Operation – Using the Sprayer

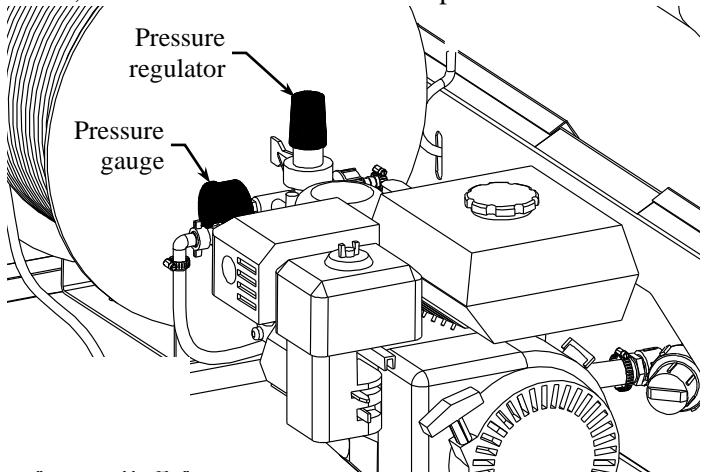
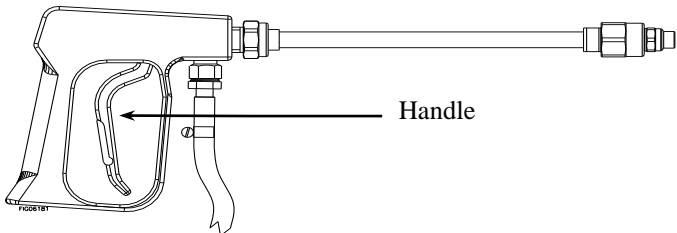
<p>9. Adjust pressure as needed</p>	<p>Turn the pressure regulator until desired pressure is achieved. Turn clockwise to increase pressure, counterclockwise to decrease pressure. Do not exceed 350psi.</p> <div style="text-align: center;">  </div>
<p>10. Operate spray gun (as needed for application)</p>	<p>Proper Operation of the Spray Gun.</p> <ol style="list-style-type: none"> 1. Squeeze the handle to begin spraying. 2. To change nozzles, use a 13/16 wrench to remove the nozzle and nozzle adapter from the spray gun or lance extension. 3. Install the desired nozzle and nozzle adapter to the spray gun or lance extension. <div style="text-align: center;">  </div> <p>IMPORTANT: ALWAYS hold the spray gun with a firm grip when spraying at higher pressures to prevent gun from whipping. Keep good footing and balance at all times.</p> <p>NOTE: It is not unusual for the operator to be exposed to chemical while operating the spray gun—gloves should be chemical resistant.</p>
<p>11. Leaving unattended</p>	<p>If the sprayer must be left unattended at any time:</p> <ol style="list-style-type: none"> a) Turn off power to the sprayer. b) Relieve system pressure by depressing the gun trigger. c) Turn off the vehicle. Set brake or block the wheels.
<p>12. Discontinue use if clogged or inoperative</p>	<p>If the sprayer becomes clogged or inoperative during use, <i>discontinue use immediately.</i></p> <ul style="list-style-type: none"> - DO NOT attempt to service while chemicals are in the sprayer and engine is running. - Return to service area to review instructions for troubleshooting before attempting to service.

Note: A reserve, clean container capable of holding at least 55 gallons should be kept for use when the sprayer tank needs to be emptied temporarily for repairs. It is advisable to purchase a reserve tank suitable for chemical storage from Northern Tool and Equipment for use in these circumstances. The container should be properly labeled as to its contents if it is used.

Operation – Using the Sprayer

Step Five: Clean sprayer and decontaminate after use.

When done using the sprayer, it is important to clean the sprayer and decontaminate yourself. Do not store the sprayer with chemicals in the tank, as it is unsafe and could also result in damage to the equipment.

⚠ WARNING

- Clean-up and decontamination procedures must be followed after each use.
- Improper equipment clean-up and disposal of chemicals can result in dangerous chemical exposure to humans and the environment, as well as equipment damage.
- Personal decontamination is required after spraying to minimize unsafe exposure to chemicals and potential illness.

1. Drain tank

If there is excess chemical left in tank, drain the tank.

- a) Turn off the engine and relieve system pressure by operating the spray gun.
- b) Find a suitable container in which to drain the unused chemical. Place it under the strainer cap.
- c) While wearing rubber gloves, eye protection, and all other required personal protective equipment, close the suction line ball valve and remove strainer cap and strainer element.
- d) Open suction line ball valve and drain tank into the suitable container.
- e) When tank stops draining, replace strainer element and tighten strainer cap securely.

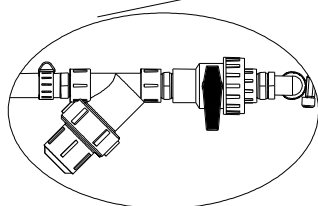
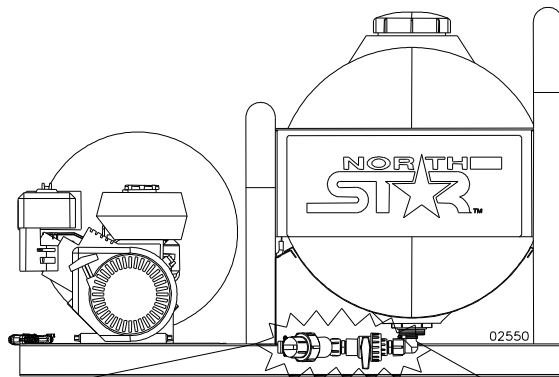

Close suction line ball valve

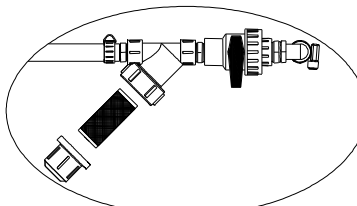

Remove strainer and remove debris

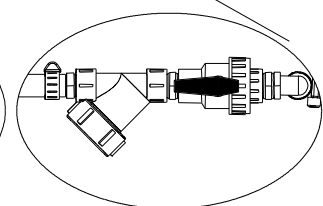

Open suction line ball valve to drain tank

Operation – Using the Sprayer

2. Unused chemical	<p>Properly store or dispose of unused chemical:</p> <p>a) <u>If the unused chemical is to be stored for future use:</u> Store all unused chemical in its original, or a suitably marked, container in a secure location out of the reach of children & animals.</p> <p>b) <u>If remaining chemical is to be disposed:</u> Properly dispose of the remaining chemical and its container per the chemical manufacturer’s recommendation and according to local hazardous waste disposal regulations.</p>
3. Flush sprayer	<p>Flush the sprayer per the chemical manufacturer’s recommendations. A general procedure is as follows:</p> <p>a) Add fresh water to the tank.</p> <p>b) Start the engine.</p> <p>c) Operate the spray gun and discharge all rinse water onto an area that can accept dilute chemical application.</p> <p>d) Add 5 gallons of the chemical manufacturer’s recommended cleaning solution. Operate the spray gun, collecting the discharged solution if recommended by the manufacturer.</p> <p>e) After flushing, turn off the engine and be sure all system pressure is relieved by operating the gun.</p> <p>f) Dispose of cleaning solution discharge as recommended by the manufacturer of the solution.</p>
4. Decontaminate & launder	<p>Decontaminate yourself after you are finished handling chemicals:</p> <p>a) Remove all clothing worn during spraying and chemical handling.</p> <p>b) Wash all exposed parts of the body with soap and water.</p> <p>c) Launder clothing separately from other wash.</p>

Storage

Prepare the sprayer for end-of-season storage by running **RV antifreeze** (DO NOT USE automotive antifreeze) through the system. This will keep internal parts lubricated, protect against corrosion, and keep the unit from freezing.

⚠ WARNING

Gasoline vapors can ignite and cause a fire. Select a well-ventilated storage area away from sources of heat, flame, or sparks.

CAUTION

- The pump will be damaged if it freezes.
- Protect the pump from freezing during storage by following the instructions below.

Preparing for storage:

1. Flush with water	<p>Fill the tank with fresh water and run through the system. Operate the spray gun until the system is completely flushed.</p> <p>DO NOT add antifreeze before flushing the system as bleach can react with antifreeze.</p>
2. Add antifreeze	<p>Pour 2 gallons of RV antifreeze (DO NOT USE automotive antifreeze) into the tank.</p> <p><i>NOTE: RV antifreeze is non-toxic and biodegradable and generally safer for the environment than automotive antifreeze.</i></p>
2. Spray briefly	<p>Start the sprayer and squeeze the gun trigger briefly until fluid sprays.</p>
3. Engine manual	<p>Refer to the engine manual for proper engine storage instructions.</p> <p>- Always disable the engine for storage by unplugging the spark plug wire.</p> <p>CAUTION: Gasoline will oxidize and deteriorate in storage. Old gasoline in the engine will cause hard starting and leave gum deposits that can clog the fuel system. Deterioration problems may occur within a few months, or even less if gasoline was not fresh when you filled the fuel tank.</p> <p>Short-Term Storage: Consider adding a fuel stabilizer to extend fuel storage life.</p> <p>Long Term Storage: (between infrequent uses and at end of season) Drain the fuel tank and carburetor as instructed in the engine owner's manual.</p> <p><u>Important Safety Instructions:</u></p> <ul style="list-style-type: none"> • Always drain fuel from tank in outdoor, well-ventilated area. • Stay away from sources of heat, flame, or sparks while handling fuel. • Clean up fuel spills/splashes immediately.
4. Sprayer storage location	<p>Store the sprayer in a location away from corrosive material, sources of heat, open flames, sparks or pilot lights.</p> <p>WARNING: Never store sprayer inside where there is a source of heat or an open flame, spark, or pilot light as on water heaters, space heaters, furnaces, clothes dryers, or other gas appliances EVEN IF the sprayer's gas tank is empty.</p>
5. Gasoline storage	<p>Store gasoline in a cool, dry place in a UL approved, tightly sealed container.</p> <p>WARNING: Gasoline vapors can ignite if they collect inside an enclosure and an explosion can result.</p>

Removing from storage:

1. Drain	<p>Drain the antifreeze left in tank. (See cleaning section of Operation Instructions.)</p>
2. Flush with water	<p>Fill the tank with fresh water and run through the system. Operate the spray gun until the system is completely flushed. Be sure to set up containers to capture the antifreeze flush water.</p> <p>DO NOT add bleach back into the sprayer before flushing the system as bleach can react with antifreeze</p>
3. Disposal	<p>Dispose of the antifreeze and flush water properly.</p>

Troubleshooting

⚠ WARNING

Before troubleshooting or attempting to service, read the following safety rules to avoid accidental exposure to chemical and risk of electric shock.

Note: A reserve, clean container capable of holding at least 55 gallons should be kept for use when the sprayer tank needs to be emptied temporarily for repairs. It is advisable to purchase a reserve tank suitable for chemical storage from Northern Tool and Equipment for use in these circumstances. The container should be properly labeled as to its contents if it is used.

Before attempting to service the sprayer:

1. Personal protective equipment	Wear personal protective equipment as directed on the chemical label while servicing your sprayer.
2. Review troubleshooting table	Review the Troubleshooting Table below for the type of problem you are experiencing. However, DO NOT attempt to repair until the steps listed below are followed.
3. Empty and flush	If the cause listed for your problem is Clogged intake tube, Clogged suction strainer, or Worn spray gun nozzle: empty the tank and flush the sprayer with water as directed in the section, “Operation – Step Four”. <i>- In order to avoid accidental exposure to chemicals, never attempt to unclog the intake tube or suction strainer, or service the spray gun nozzle, until the tank has been emptied and the sprayer flushed with water.</i>
4. Disconnect power/relieve pressure	Stop the engine and be sure all system pressure is relieved by operating the spray gun. Unplug spark plug wire.
5. Perform repairs	Follow the directions provided in the troubleshooting table to repair the sprayer. <i>NOTE: Never try to unclog the sprayer nozzle by blowing through it.</i>
6. Test after servicing	After servicing, ALWAYS test the sprayer for leaks with plain water before using.

PROBLEM	CAUSE	SOLUTION
Engine will not start	Engine will not start	See engine owner’s manual
Low pressure	Agitation not tuned properly	Tune agitator with desired agitator tip
	Pressure regulator not adjusted	Adjust pressure regulator
	Worn spray gun nozzle	Replace spray gun nozzle
	Leak in the system	Tighten leaking fitting/hose
Low flow	Agitation valve is open	Close agitation valve
	Agitation not tuned properly	Tune agitator with desired agitator tip
	Strainer clogged	Remove strainer and clean
	Clogged suction line	Remove obstruction
Poor spray distribution	Worn spray gun nozzle	Replace spray gun nozzle
Output drops and the pump is noisy	Pump failure	See pump owner’s manual

Specifications

Sprayer Specifications

Engine.....	5.5 HP Honda GX160
Pump.....	Comet MC25
Pump Oil.....	30 weight, Non-detergent
Tank Maximum Capacity.....	55 Gallons
Maximum GPM.....	5.0 GPM
Maximum Pressure.....	350 PSI
Spray gun hose length.....	150 ft.
Maximum hose reel capacity.....	250 ft. of 3/8" hose
Overall Dimensions.....	46.5" L x 40" W x 32" H
Dry Weight.....	220 lbs.
Weight full of liquid.....	Approx. 660 lbs.

Component Materials*

Tank.....	Polyethylene
Fittings.....	Polypropylene, Nylon
Suction line ball valve....	Polypropylene, EPDM, Teflon
Suction line strainer.....	Polypropylene, EPDM, Stainless steel
Hose.....	PVC
Pump.....	Aluminum, Desmopan, Stainless Steel
Hose reel.....	Steel, Brass, Teflon
Gun and Nozzle.....	Brass, Stainless Steel, Teflon

*Before using any chemical, check to ensure the chemical is compatible with all materials in the system.

The manufacturer reserves the right to make improvements in design and/or changes in specifications at any time without incurring any obligation to install them on units previously sold.

Any Questions, Comments, Problems or Parts Orders
Call NorthStar Product Support 1-800-270-0810

Exploded View – Rev A.1

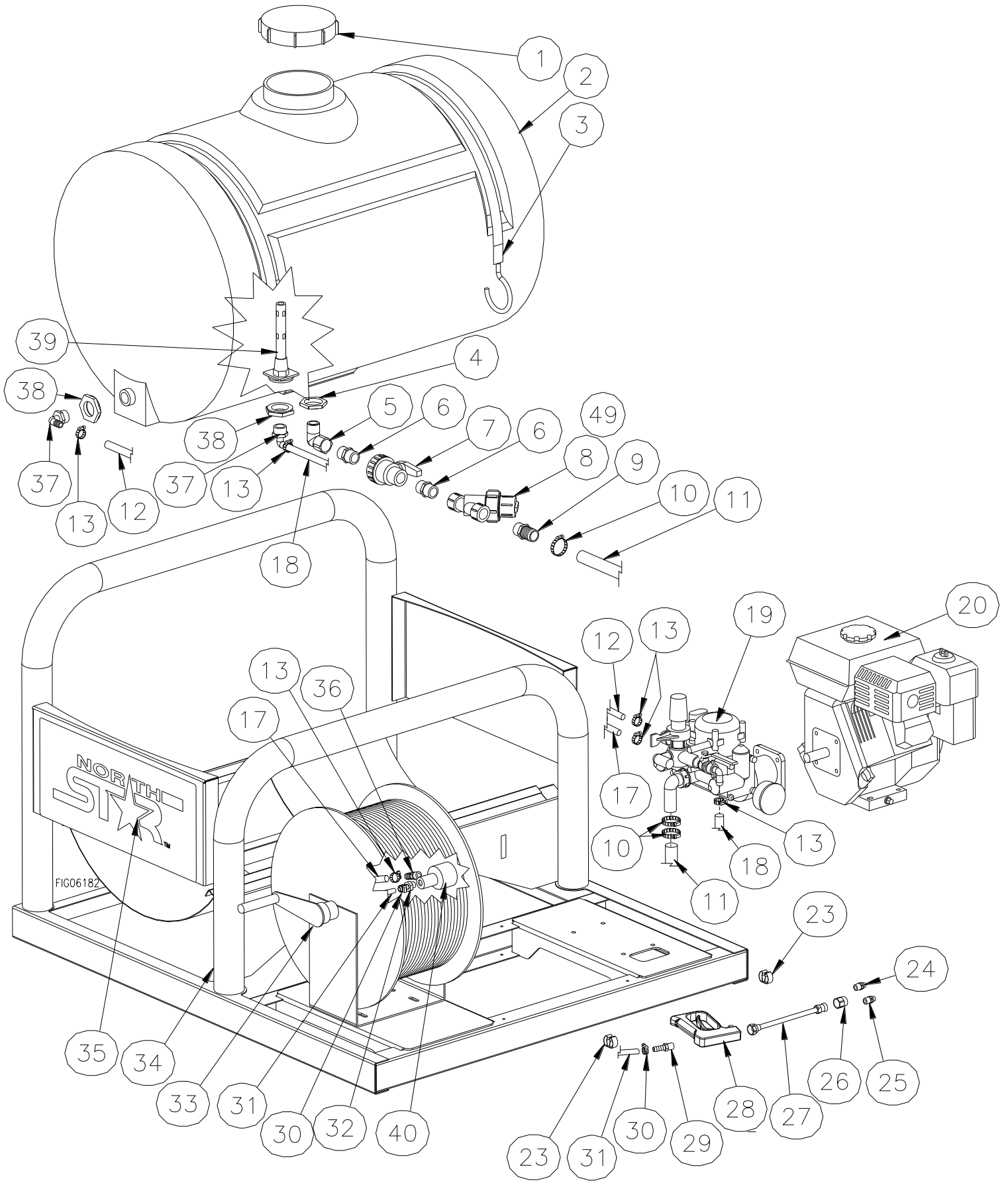

Exploded View – Rev A.1

Item	Part Number	Description	Qty.
1	SNY34300047	55 Gallon Tank Lid	1
2	796777	55 Gallon Sprayer Tank Assembly (includes items 38 and 39)	1
3	5262	Ratchet Tie Down	2
4	SNY34700002	Anti Vortex Fitting	1
5	779213	3/4" Male NPT x 3/4" Female NPT Elbow	1
6	779270	3/4" Hex Nipple	2
7	52101	3/4" x 3/4" Female NPT Ball Valve	1
8	797209	Strainer, 3/4" Y-Line	1
9	779214	3/4" Male NPT x 1" Hose Barb	1
10	17147	1" Hose Clamp	3
11	30917	1" Suction Hose	15"
12	30160	1/2" Reinforced PVC Hose	34"
13	777119	1/2" Hose Clamp	6
17	30192	1/2" 600# PVC Hose (High Pressure Line)	11"
18	30192	1/2" 600# PVC Hose (Agitation Line)	34"
19	779122	Comet MC25 Diaphragm Pump	1
20	6059	Honda GX160 5.5HP Engine	1
23	52034	Lance Clip	2
24	779210	Fan Nozzle	1
25	779211	Straight Stream Nozzle	1
26	779255	Nozzle Adapter	2
27	779212	8" Lance Extension	1
28	797844	Spray Gun	1
29	779216	3/8" Hose Barb x 1/4" Male NPT Brass	1
30	30746	3/8" Hose Clamp	2
31	779256	3/8" 350PSI Hose	150'
32	779219	3/8" Male NPT x 3/8" Hose Barb	1
33	779257	Hose Reel	1
34	779111	PCO Skid Frame	1
35	777725	NorthStar Decal	2
36	777839	3/8" Male NPT x 1/2" Hose Barb	1
37	779269	3/4" Male NPT x 1/2" Hose Barb Elbow	2
38	5370	3/4" Female NPT Bulkhead	2
39	777843	Tank Agitator	1
40	CX19351	Swivel fitting	1
49	49030187	Strainer mesh replacement for 797209	1

Pump Exploded View

• MC 25 •

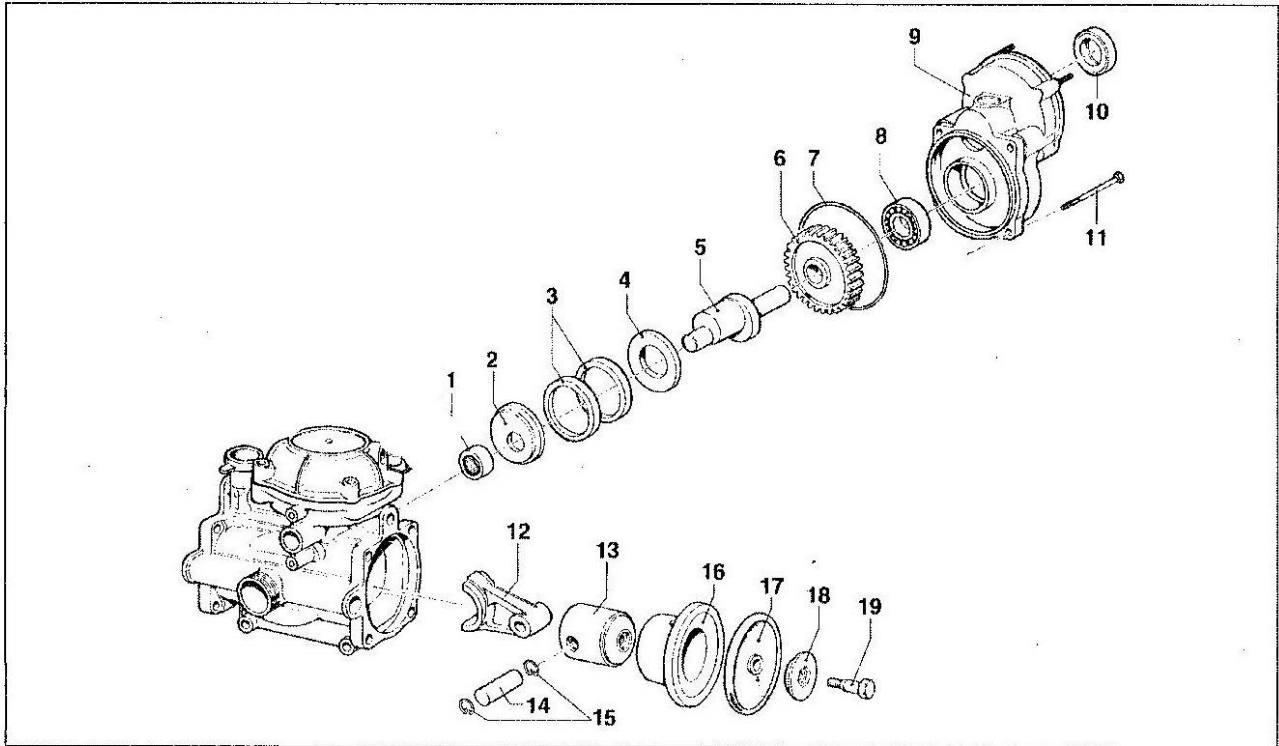

Regulator shown separately

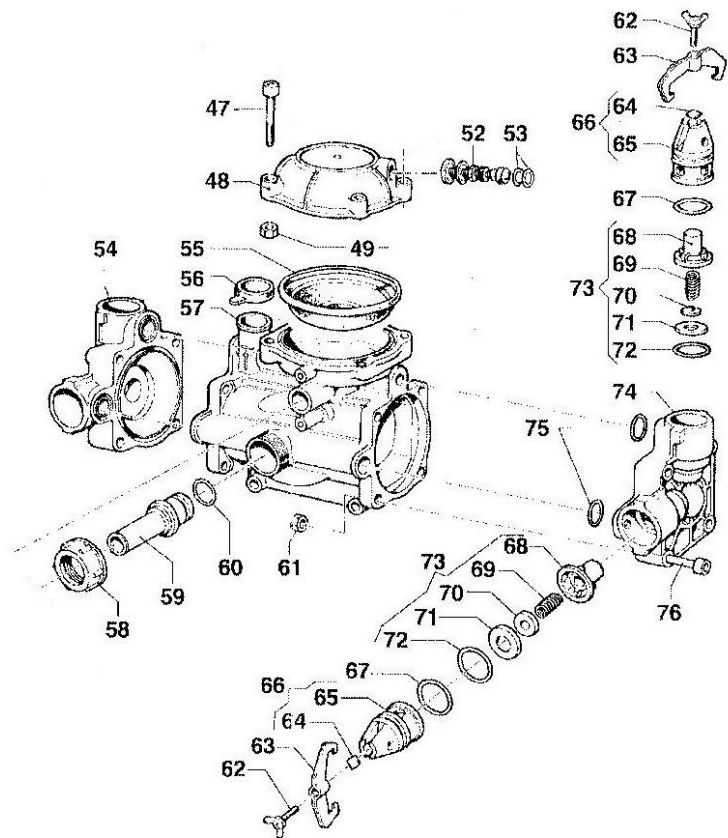

Pump Exploded View

Reference	Part Number	Description	Qty
1	0437001700	Bearing	1
2	0601023500	Spacer	1
3	0010001200	Conn rod ring	2
4	2813007300	Conn rod washer	1
5	0001029100	Shaft	1
6	0409001900	Gear	1
7	1210005300	O-ring	1
8	0438006500	Bearing	1
9	3002049100	Support	1
10	0019008600	Oil seal	1
11	3609017300	Screw	4
12	0205005900	Conn rod ass'y	1
13	2409002300	Piston	2
14	3011000600	Pin	2
15	3020002000	Retaining clip	4
16	0400006900	Piston sleeve	2
17	1800002000	Diaphragm	2
18	0602003300	Disc	2
19	3605002700	Screw	2

47	3609016500	Screw	2
48	0003001100	Press acc'r	1
49	0604006300	Nut	4
50	3609016200	Screw	2
51	2811001600	Washer	2
52	3610000300	Air valve	1

Reference	Part Number	Description	Qty
53	1209003300	Gasket	2
54	3218001500	Pump manifold	1
55	1800003300	Diaphragm	1
56	1800007900	Diaphragm	1
57	0403013400	Pump crankcase	1
58	1200000800	Wing nut	1
59	2801003100	Suction barb	1
60	1210004600	O-ring	1
61	0604006300	Nut	8
62	3605003200	Screw	4
63	0418001800	U clip	4
64	2403007500	Plate	4
65	3202002700	Plug	4
66	3202021400	Tap	1
67	1210005200	O-ring	4
68	1205000700	Valve cage	4
69	1802001500	Spring	4
70	3604000700	Valve	4
71	3009002300	Valve seat	4
72	1210002900	O-ring	4
73	1212000400	Valve kit	4
74	3218001600	Manifold	1
75	1210004600	O-ring	4
76	3609016200	Screw	8

Reference	Part Number	Description	Qty
Repair Kit #5026011600			
7	1210005300	O-ring	1
17	1800002000	Diaphragm	2
24	0015001300	Rod	1
26	1216000600	Gasket	1
30	1210005700	O-ring	1
31	3600008800	Regulator valve	1
33	1209003000	Gasket	1
42	1210002500	O-ring	1
55	1800003300	Acc'r diaphragm	1
56	1800007900	Oil cap	1
60	1210004600	O-ring	1
67	1210005200	O-ring	4
73	1212000400	Valve	4

Pump Exploded View

MC 25 Regulator CO1204067400

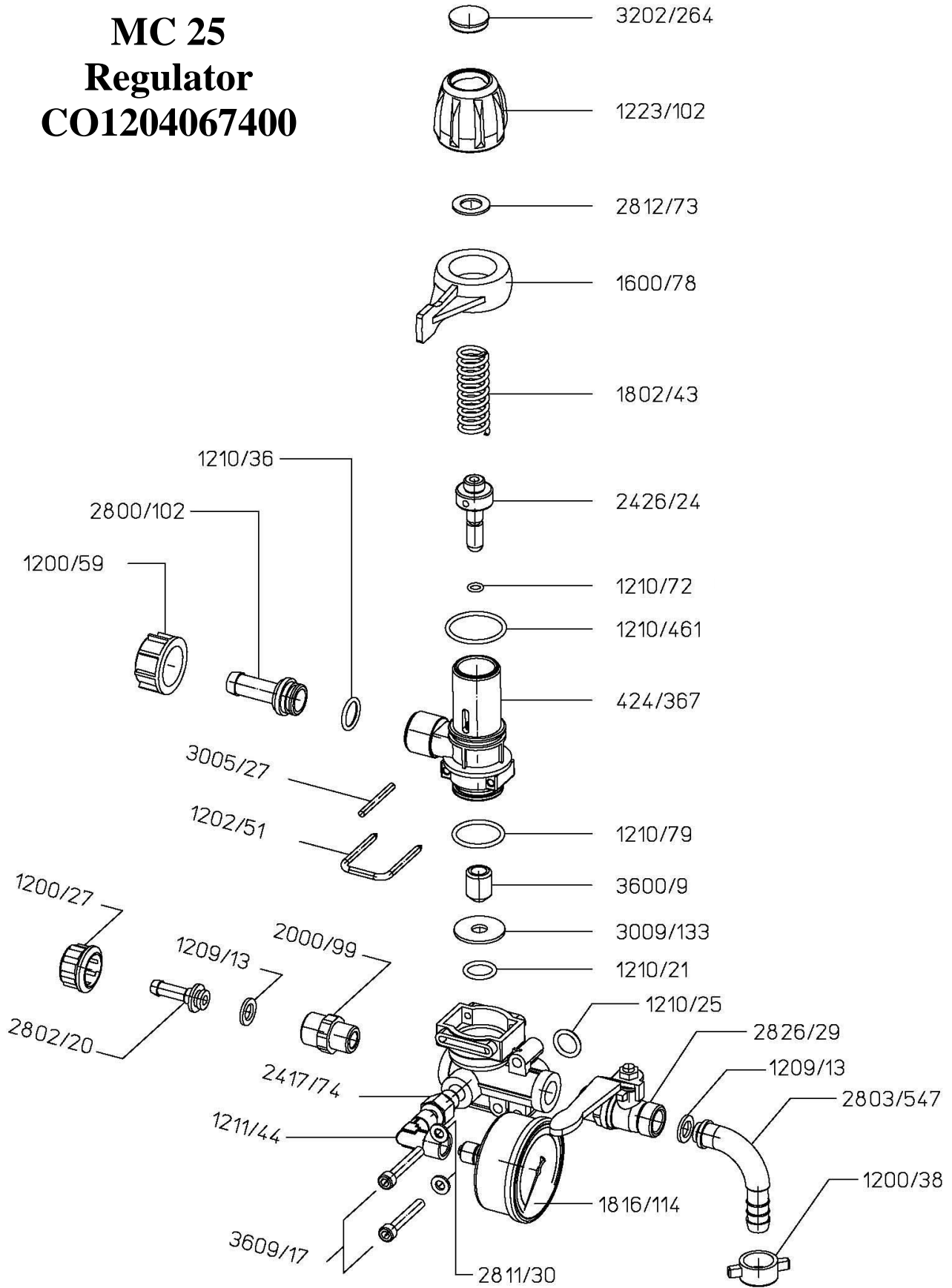

Limited Warranty

Dear Valued Customer:

The NorthStar Product you just purchased is built with the finest material and craftsmanship. Use this product properly and enjoy the benefits from its high performance. By purchasing a NorthStar product, you show a desire for quality and durability.

Like all mechanical equipment this unit requires a due amount of care. Treat this unit like the high-quality piece of machinery it is. Neglect and improper handling may impair its performance. Please thoroughly read the instructions and understand the operation before using your product.

Limited Warranty

NorthStar shall warranty any piece of equipment manufactured, or parts of equipment manufactured, to be free from defects in material or workmanship for a period of 90 days from the date of purchase by user. This warranty applies to the original purchaser of the equipment and is nontransferable. Verification of purchase is the responsibility of the buyer. Parts will be replaced or repaired at no charge, except when the equipment has failed due to lack of proper maintenance. Any misuse, abuse, alteration or improper installation or operations will void warranty. Determining whether a part is to be replaced or repaired is the sole decision of NorthStar.

NOTE: Some services performed by parties other than NorthStar may void warranty.

This warranty covers parts only. It will not provide for replacement of complete products due to defective parts. Components not manufactured by NorthStar such as engines are guaranteed by their manufacturer and can be serviced at factory-authorized locations near you. Any costs incurred due to replacement or repair of items outside of a NorthStar approved facility is the responsibility of the buyer and not covered under warranty. NorthStar can supply you with the service center location in your area.

This warranty specifically excludes the following; failure of parts due to damage caused by accident, fire, flood, windstorm, acts of God, applications not approved by NorthStar in writing, corrosion caused by chemicals, use of replacement parts which do not conform to manufacturer's specifications, and damage caused by vandalism. Additional exclusions: loss of running time, inconvenience, loss of income, or loss of use, including any implied warranty of merchantability of fitness for a specific use.

Warranty does not cover items subject to normal wear such as tires, receptacles or any part subject to direct physical contact by the public. This warranty does not cover any personal injury or damage to surrounding property caused by failure of any part.

This warranty is in lieu of any other warranty expressed or implied and NorthStar assumes no other responsibility or liability outside that expressed within this warranty.

Please fill in the following information and have it on hand when you call in a warranty claim.

Customer Number: _____

Date of Purchase: _____

NorthStar Serial Number: _____

Item Number: _____

▲ WARNING: This product can expose you to chemicals including gasoline engine exhaust, which is known to the State of California to cause cancer, and carbon monoxide, which is known to the State of California to cause birth defects or other reproductive harm.

For more information go to www.P65Warnings.ca.gov.



Manufactured by
Northern Tool + Equipment Co.,
2800 Southcross Drive West
P.O. Box 1499 Burnsville, MN 55337-0499