



# MINI CEMENT MIXER

## OWNER'S MANUAL



### **WARNING:**

Read carefully and understand all INSTRUCTIONS before operating. Failure to follow the safety rules and other basic safety precautions may result in serious personal injury.

**Item # 998250**

Thank you very much for choosing a NORTHERN TOOL + EQUIPMENT CO., INC. Product! For future reference, please complete the owner's record below:

Model: \_\_\_\_\_ Purchase Date: \_\_\_\_\_

Save the receipt, warranty and these instructions. It is important that you read the entire manual to become familiar with this product before you begin using it.

This machine is designed for certain applications only. Northern Tool + Equipment cannot be responsible for issues arising from modification. We strongly recommend this machine is not modified and/or used for any application other than that for which it was designed. If you have any questions relative to a particular application, DO NOT use the machine until you have first contacted Northern Tool + Equipment to determine if it can or should be performed on the product.

For technical questions please call **1-800-222-5381**.

## INTENDED USE

The Cement Mixer is designed for mixing cement and is small, efficient, easy to use and easy to assemble. Convenient to transport and store.

## TECHNICAL SPECIFICATIONS

Item	Description
Motor	120VAC, 60Hz, 180 Watts
Motor Speed	1200 RPM
Drum Opening	10" (255mm)
Drum Rotation Speed	30 RPM
Drum Capacity	1.77 cu. ft.

## GENERAL SAFETY RULES



**WARNING: Read and understand all instructions.** Failure to follow all instructions listed below may result in electric shock, fire and/or serious injury.



**WARNING: The warnings, cautions, and instructions discussed in this instruction manual cannot cover all possible conditions or situations that could occur.** It must be understood by the operator that common sense and caution are factors which cannot be built into this product, but must be supplied by the operator.

## SAVE THESE INSTRUCTIONS

## WORK AREA

- **Keep work area clean**, free of clutter and well lit. Cluttered and dark work areas can cause accidents.
- **Do not use your tool where there is a risk of causing a fire or an explosion;** e.g. in the presence of flammable liquids, gasses, or dust. Power tools create sparks, which may ignite the dust or fumes.
- **Keep children and bystanders** away while operating a power tool. Distractions can cause you to lose control, so visitors should remain at a safe distance from the work area.
- **Be aware of all power lines, electrical circuits,** water pipes and other mechanical hazards in your work area, particularly those hazards below the work surface hidden from the operator's view that may be unintentionally contacted and may cause personal harm or property damage.
- **Be alert of your surroundings.** Using power tools in confined work areas may put you dangerously close to cutting tools and rotating parts.

## ELECTRICAL SAFETY

-  **WARNING:** Always check to ensure the power supply corresponds to the voltage on the rating plate.
- **Do not abuse the cord.** Never carry a portable tool by its power cord, or yank tool or extension cords from the receptacle. Keep power and extension cords away from heat, oil, sharp edges or moving parts. Replace damaged cords immediately. Damaged cords may cause a fire and increase the risk of electric shock.
- **Grounded tools** must be plugged into an outlet properly installed and grounded in accordance with all codes and ordinances. Never remove the grounding prong or modify the plug in any way. Do not use any adapter plugs. Check with a qualified electrician if you are in doubt as to whether the outlet is properly grounded.
- **Double insulated tools** are equipped with a polarized plug (one blade is wider than the other). This plug will fit in a polarized outlet only one way. If the plug does not fit fully in the outlet, reverse the plug. If it still doesn't fit, contact a qualified electrician to install a polarized outlet. Do not change the plug in any way.
- **Avoid body contact** with grounded surfaces such as pipes, radiators, ranges, and refrigerators. There is an increase risk of electric shock if your body is grounded.
- **When operating a power tool outside,** use an outdoor extension cord marked "W-A" or "W." These cords are rated for outdoor use and reduce the risk of electric shock.
- **Extension Cord Use:**
  - A. Use only 'Listed' extension cords. If used outdoors, they must be marked "For Outdoor Use." Those cords having 3-prong grounding type plugs and mating receptacles are to be used with grounded tools.
  - B. Replace damaged or worn cords immediately.
  - C. Check the name plate rating of your tool. Use of improper size or gauge of extension cord may cause unsafe or inefficient operation of your tool. Be sure your extension cord is rated to allow sufficient current flow to the motor. For the proper wire gauge for your tool, see chart.

**CHART FOR MINIMUM WIRE SIZE OF EXTENSION CORD:**

Nameplate AMPS	CORD LENGTH			
	25'	50'	100'	150'
0-6	18 AWG	16 AWG	16 AWG	14 AWG
6-10	18 AWG	16 AWG	14 AWG	12 AWG
10-12	16 AWG	16 AWG	14 AWG	12 AWG
12-16	14 AWG	12 AWG	(NOT RECOMMENDED)	

If in doubt, use larger cord.

Be sure to check voltage requirements of the tool to your incoming power source.

- ☐ **Do not expose** power tools to rain or wet conditions. Water entering a power tool will increase the risk of electric shock.
- ☐ **Do not let your fingers** touch the terminals of plug when installing to or removing from the outlet.
- ☐ **Ground fault circuit interrupters.** If work area is not equipped with a permanently installed Ground Fault Circuit Interrupter outlet (GFCI), use a plug-in GFCI between power tool or extension cord and power receptacle.

## PERSONAL SAFETY

- ☐ **Stay alert,** watch what you are doing and use common sense when operating a power tool. Do not use a power tool while you are tired or under the influence of drugs, alcohol or medication. A moment of inattention while operating power tools may result in serious personal injury.
- ☐ **Dress properly.** Do not wear loose clothing, dangling objects, or jewelry. Keep your hair, clothing and gloves away from moving parts. Loose clothes, jewelry or long hair can be caught in moving parts. Air vents often cover moving parts and should be avoided.
- ☐ **Use safety apparel and equipment.** Use safety goggles or safety glasses with side shields which comply with current national standards, or when needed, a face shield. Use as dust mask in dusty work conditions. This applies to all persons in the work area. Also use non-skid safety shoes, hardhat, gloves, dust collection systems, and hearing protection when appropriate.
- ☐ **Avoid accidental starting.** Do not carry the power tool with your finger on the switch. Ensure the switch is in the off position before plugging tool into power outlet. In the event of a power failure, while a tool is being used, turn the switch off to prevent surprise starting when power is restored.
- ☐ **Do not overreach.** Keep proper footing and balance at all times.
- ☐ **Remove adjusting keys or wrenches** before connecting to the power supply or turning on the tool. A wrench or key that is left attached to a rotating part of the tool may result in personal injury.
- ☐ **Never stick** your hands and/or tools into the Drum Assembly while the Cement Mixer is in operation.

## TOOL USE AND CARE

- ☐ **Do not** overload mixer.
- ☐ **Keep hands free** from the drum when in operation.
- ☐ **Always operate** mixer on a solid, flat, level surface that is capable of supporting the weight of the mixer and its load.
- ☐ **Never start or stop** the mixer with any material in the drum otherwise the motor will be damaged.
- ☐ **Never use a tool** with a malfunctioning switch. Any power tool that cannot be controlled with the switch is dangerous and must be repaired by an authorized service representative before using.

- **Disconnect the power from mixer** and place the switch in the locked or off position before servicing, adjusting, installing accessories or attachments, or storing. Such preventive safety measures reduce the risk of starting the power tool accidentally.
- **Store idle tools.** When tools are not in use, store them in a dry, secure place out of the reach of children. Inspect tools for good working condition prior to storage and before re-use.
- **Check mixer** for wear and damage frequently. It is recommended that the general condition of any tool be examined before it is used. Keep your tools in good repair by adopting a program of conscientious repair and maintenance in accordance with the recommended procedures found in this manual. If any abnormal vibrations or noise occurs, turn the tool off immediately and have the problem corrected before further use. Have necessary repairs made by qualified service personnel.
- **Periodically grease** all moving parts lightly.
- **Use only accessories that are recommended** by the manufacturer for your model. Accessories that may be suitable for one tool may create a risk of injury when used on another tool.
- **Keep guards in place** and in working order.
- **Never leave** mixer running unattended.
- **Keep drum rotating** when filling or emptying the mixer.
- **When transporting** the mixer, disconnect the power cord and make sure the drum is empty of all material.
- **Keep** the cement mixer and surrounding area clean at all times.
- **Do not move** the cement mixer during operation. The mixer could tip over or the engine could be damaged.
- **Make sure all** tools, shovels, hand trowels and other equipment are removed from the cement mixer prior to turning it on.

## **ASSEMBLY** (Recommend that 2 people assist in assembly)

1. Place Stand (#1) into Hinge Bracket (#2) so that bolt holes line up as shown in Figure A (also see photo on cover page and Assembly Drawing).
2. Insert Hex Bolts (#60 & #40) through holes from one side, then Flat Washer (#45) & Spring Washer (#44) and Hex Nut (#43) from the other side, and tighten with a wrench.
3. Insert Support Bracket (#3) onto Stand (#1) so that bolt holes line up.
4. Insert Hex Bolts (#60 & #40) through holes from one side, then Flat Washer (#45) & Spring Washer (#44) and Hex Nut (#43) from the other side, and tighten with a wrench.

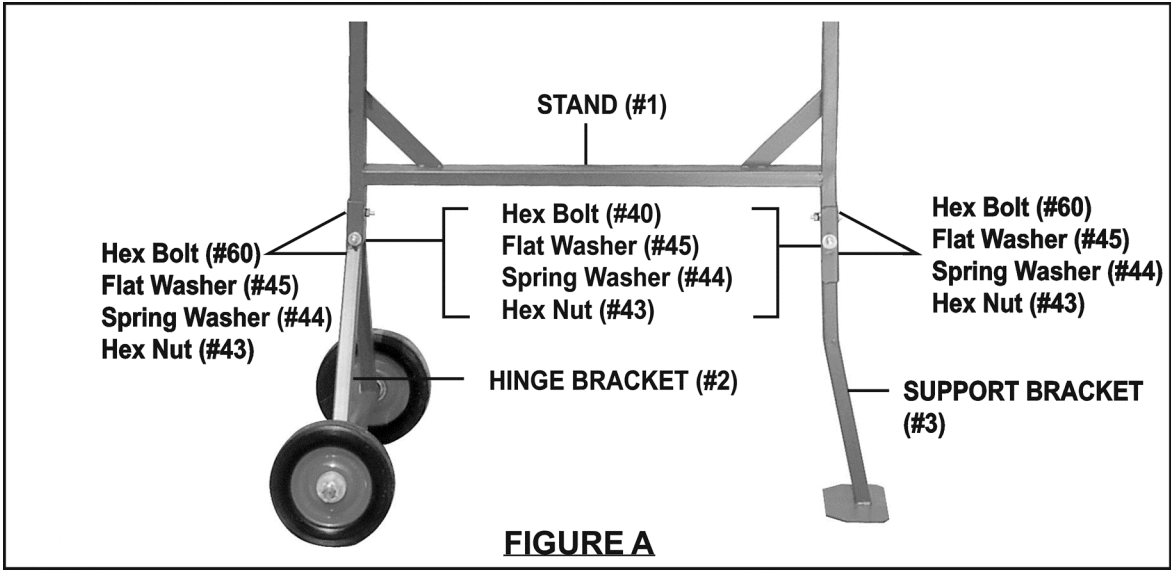

5. Secure Wheels (#4) in place using Flat Washer (#5) and Lock Nut (#7).
6. Insert Shaft Pins (#6) into the Hinge Bracket (2) axle holes, outside each Lock Nut (#7).

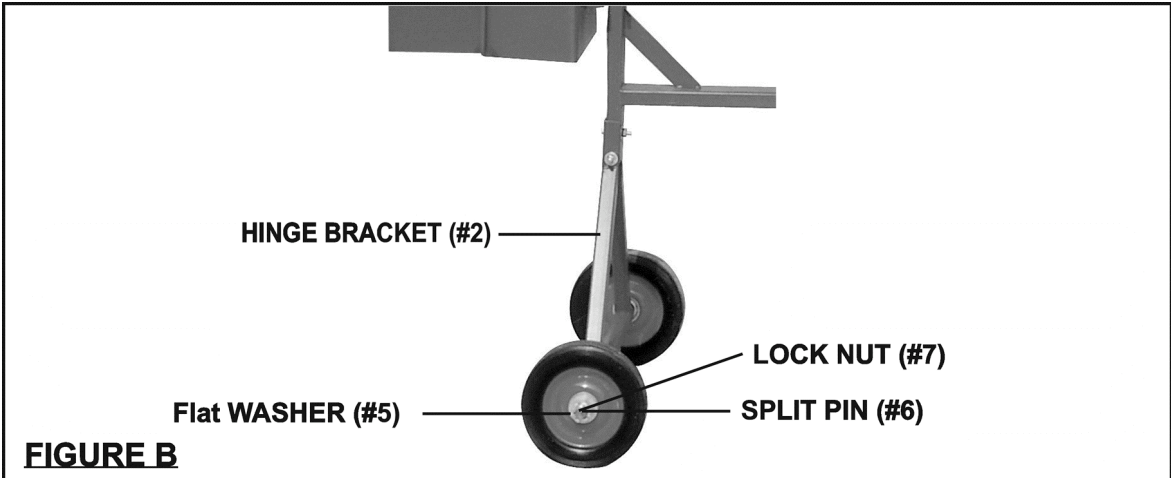

7. Bend each side of the Pins outward so they do not fall out.
8. With two people, set Lower Drum (#35) with attached Support Arm (#27) assembly into Stand assembly. See photo below.

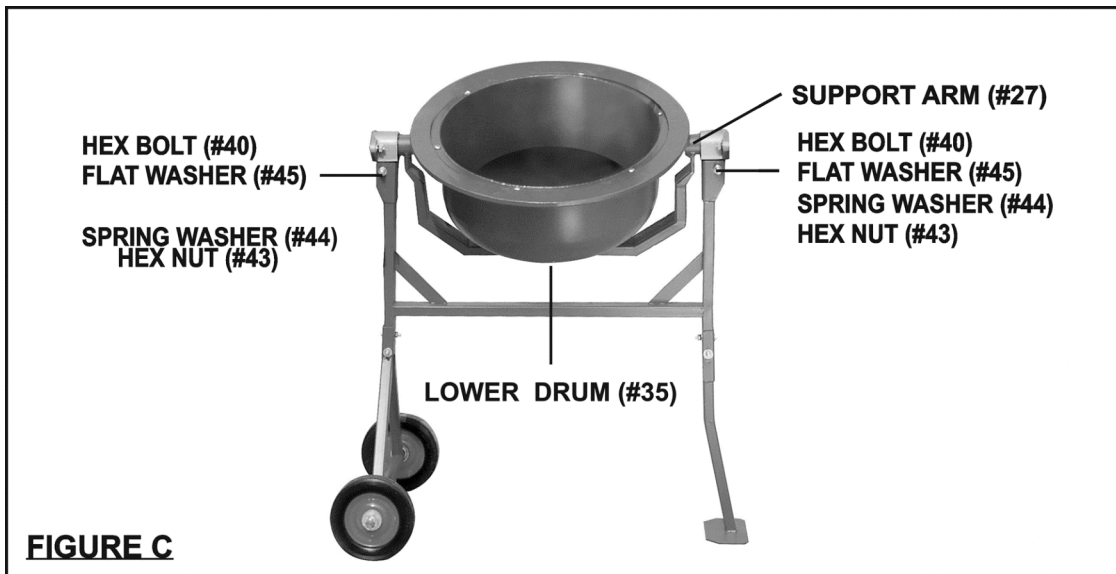

9. Insert Hex Bolts (#40) through holes from one side, then Flat Washer (#45) and Spring Washer (#44) and then Hex Nut (#43) from the other side, tighten with a wrench.
10. Mount Degree Adjusting Plate (#32) to Iron Tube Fixture (#21) using two Hex Bolts (#58) from the outside. Secure from the inside with a Flat Washer (#45), a Spring Washer (#44), and a Hex Nut (#43).

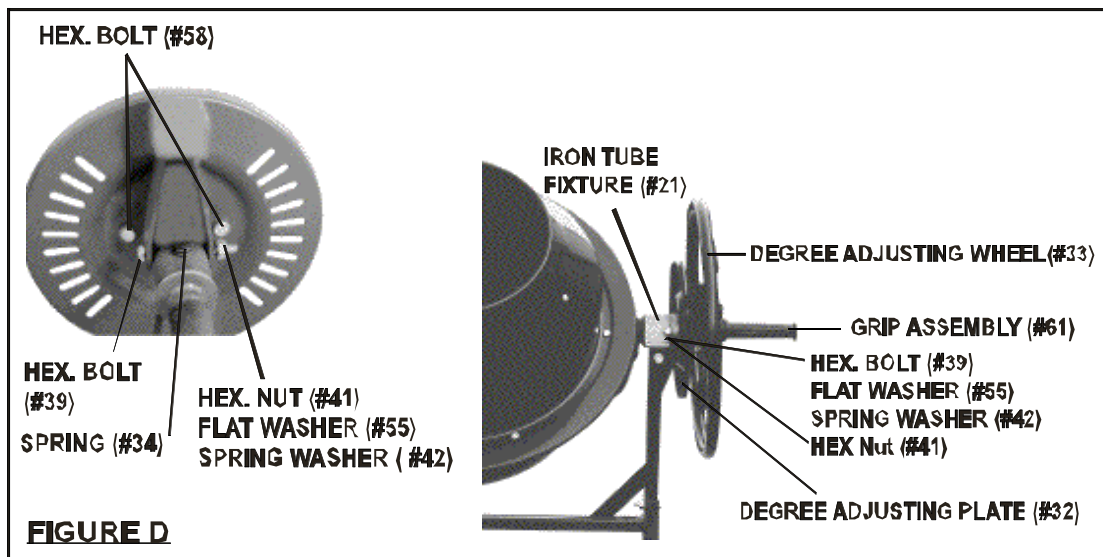

11. Attach Degree Adjust Wheel (#33) to the iron Tube Fixture (#21) shaft as shown in Figure D.
  - a.) Insert Spring (#34) into lower hole of Degree Adjusting Wheel (#33).
  - b.) Press down on Wheel until holes align on the pivot shaft.
  - c.) Insert the Hex Bolt (#39) and secure with Flat Washer (#55), Spring Washer (#42) and Hex Nut (#41).
  - d.) Tighten to a point where the Wheel can still move.
12. Glue the Rubber Seal (#36) to the Upper Drum (#37) (glue not included) making sure that the holes in both align. The Rubber Seal must be flat on the Upper Drum (#37) to ensure a proper seal.

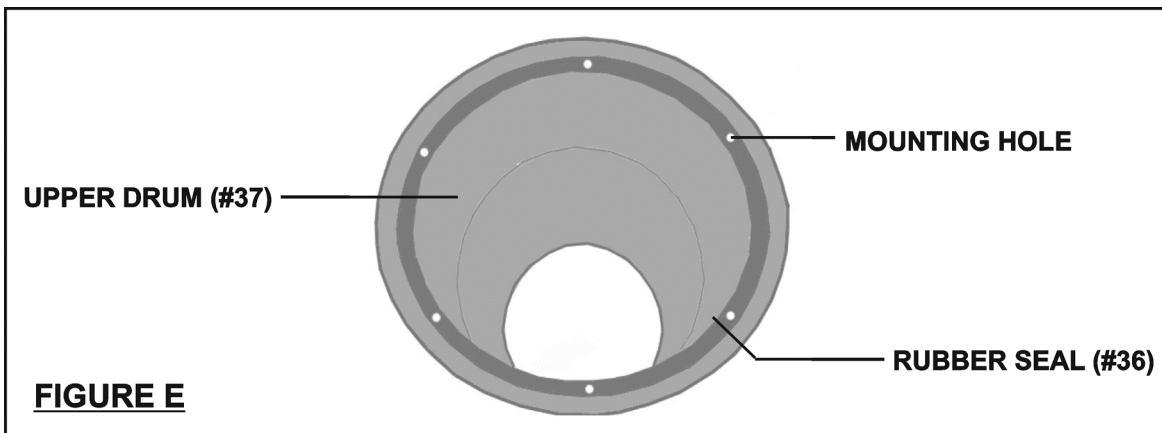

13. Place the Upper Drum (#37) on the Lower Drum (#35), making sure the mounting holes align in both.
14. Insert the six, Hex Bolts (#56) into each mounting hole. Secure each Bolt with a Flat Washer (#46) and Spring Washer (#47) and Hex Nut (#48).

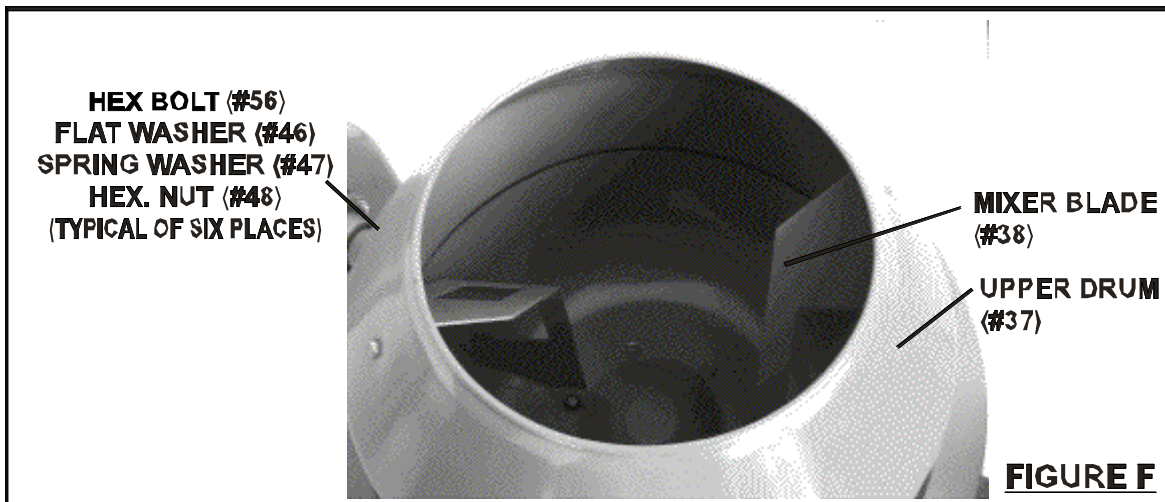

**Note:** You will need the assistance of a second person for this step. Mount each Mixer Blade (#38) inside the assembled drum. Use the Cross-Head Bolt (#53), Leather Washer (#54), and Flat Washer (#46) Spring Washer (#47) and Hex Nut (#48) to secure each Mixer Blade (#38) to the upper and lower mounting holes (see Figure F).

15. Mount the inner Motor Cover (#17) to the Iron Tube Fixture (#21) using the Hex Bolt (#58), Flat Washer (#45), Spring Washer (#44) and Hex Nut (#43).

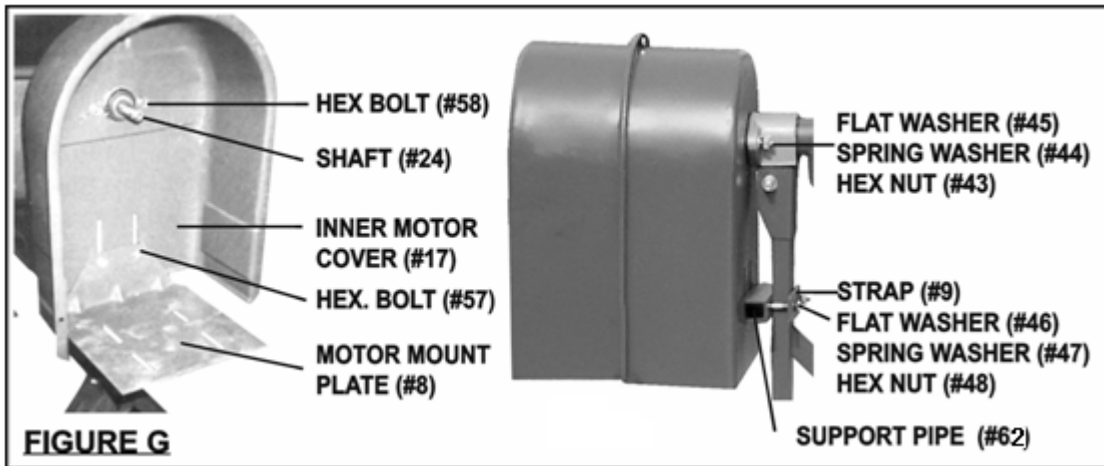

16. Attach the Motor Mount Plate (#8) to the Inner Motor Cover (#17) using the Hex Bolt (#57), Flat Washer (#46), Spring Washer (#47) Hex Nut (#48), and Strap (#9). Tighten sufficiently to hold in place. See photo above.

**Note:** Once the Motor (#12) is mounted, the Motor Mount Plate (#8) must be adjusted up or down to tighten the Belt.

17. Place the Motor (#12), attached to the power cable to the outer Motor Cover (#15), on top of the Motor Mount Plate (#8).

18. Secure the motor to the Motor Mount Plate (#8) using Hex. Bolt (#59), Flat Washer (#45) Spring Washer (#44), and Hex Nut (#43). Tighten all four Hex Nuts hand-tight. The Motor will be adjusted forward or backward later.

19. Squarely push Pulley (#16) center onto the shaft (#24) so that the groove in the pulley engages the Flat pin (#22). The Pulley (#16) should be flush with the step on the shaft.



**CAUTION:** Do not pound the Pulley onto the shaft. Damage can occur causing a loose fit.

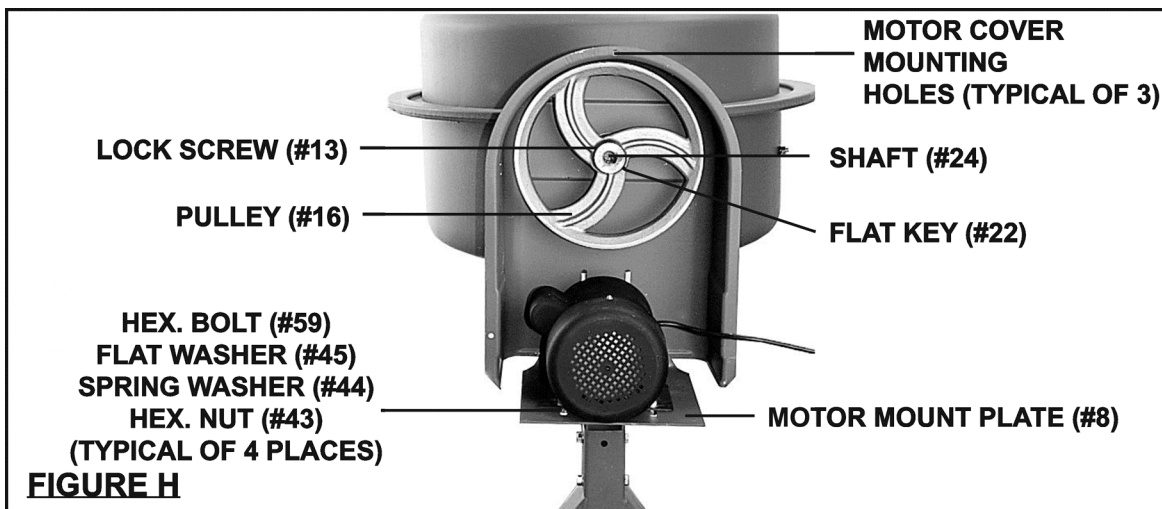

20. Once the pulley is pushed in all the way, use an Allen wrench to tighten the Lock Screw (#13) on the side of the Pulley hub.

21. Install the pulley Belt (#18). Place Belt around Motor Pulley (#10), then over the Pulley (#16). Push the Motor inward until the Motor Pulley (#10) is directly under the Pulley (#16). Tighten the

- four Hex Bolts (#59) securing the Motor to the Motor Mount Plate (#8).
22. Push the Motor downward until the Belt tension is tight. This step may require tapping down the Strap (#9) behind the Inner Motor Cover (#17). Refer to the photo at the top of the previous page. When proper tension (1/4" deflection) is achieved, tighten the Hex Nuts on the Strap (#9).
  23. Check if Motor and belt turns true. Turn the Pulley (#16) by hand and verify that the Motor pulley does not rub against any other part, and that the pulleys turn true. Make adjustments to Motor location as required.
  24. Mount the Outer Motor Cover (#15) to the Inner Motor Cover (#17) using three Cross-Head Hex Bolts (#49) and Flat Washer (#50), Spring Washer (#51) and Hex Nuts (#52). Make sure that the power cord from the Motor to the Switch Assembly (#14) does not come in contact with moving parts.
  25. The Cement Mixer assembly is complete. Go back and retighten all screws, nuts and bolts.

## OPERATION



**WARNING:** Keep hands, tools, and clothing away from moving parts of the cement mixer while it is in operation.



**WARNING:** Do not attempt to move the Cement Mixer when it is full and / or in operation. It is unsafe to move the mixer while in this condition, and severe injury to personnel could occur.

**NOTE:** Filling and emptying the Drum should be performed with the Drum Rotating.

1. Place the Cement Mixer on a solid, even surface capable of supporting the entire unit when fully loaded.
2. Adjust the drum angle by pulling out on the Degree Adjusting Arm (#33), disengaging the locking pins, and push on Arm until the desired angle is reached. Re-engage the locking pins.
3. Connect the Power Cord to an appropriate power supply.
4. Flip the Switch (#14) to the (I) or "On" position.

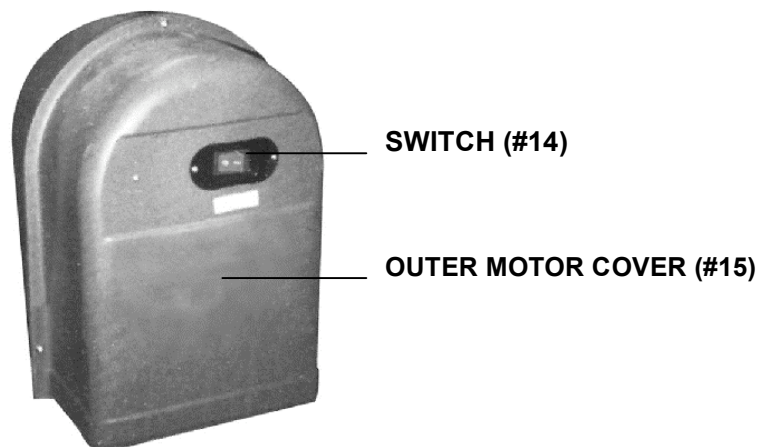

**FIGURE I**

5. Add material to the Drum. Typical maximum mixing quantities include: 3/4 gallons water, 1 shovel cement, 5 shovels aggregate rock using a size 3 shovel.



**CAUTION:** Never leave the Cement Mixer running while unattended. Do not turn Mixer Off while full of cement.

6. When finished pouring, flip the Switch to the (O) or "Off" position, and disconnect the Power Cord.
7. Turn the Drum angle as far down as possible to drain all fluids from Drum.

## MAINTENANCE



**WARNING:** Make sure this tool is turned off and disconnected from its power source before attempting any maintenance, cleaning, or inspection.

- It is recommended that the general condition of any tool be examined before it is used. Keep your tools in good repair by adopting a program of conscientious repair and maintenance in accordance with the recommended procedures found in this manual. If any abnormal vibrations or noise occurs, turn the tool off immediately and have the problem corrected before further use. Have necessary repairs made by qualified service personnel.
- After use, immediately wash out all debris from the inside and outside of the Cement Mixer.
- Keep the motor clean and free of build up.
- Do not apply water in or around the Motor Base Cover.
- Retighten belt after the every 25 hours of use. The belt should be able to be pressed in no more than 1/4".
- Periodically recheck all nuts, bolts, and screws for tightness.
- Lightly grease all moving parts.

# DIAGRAM

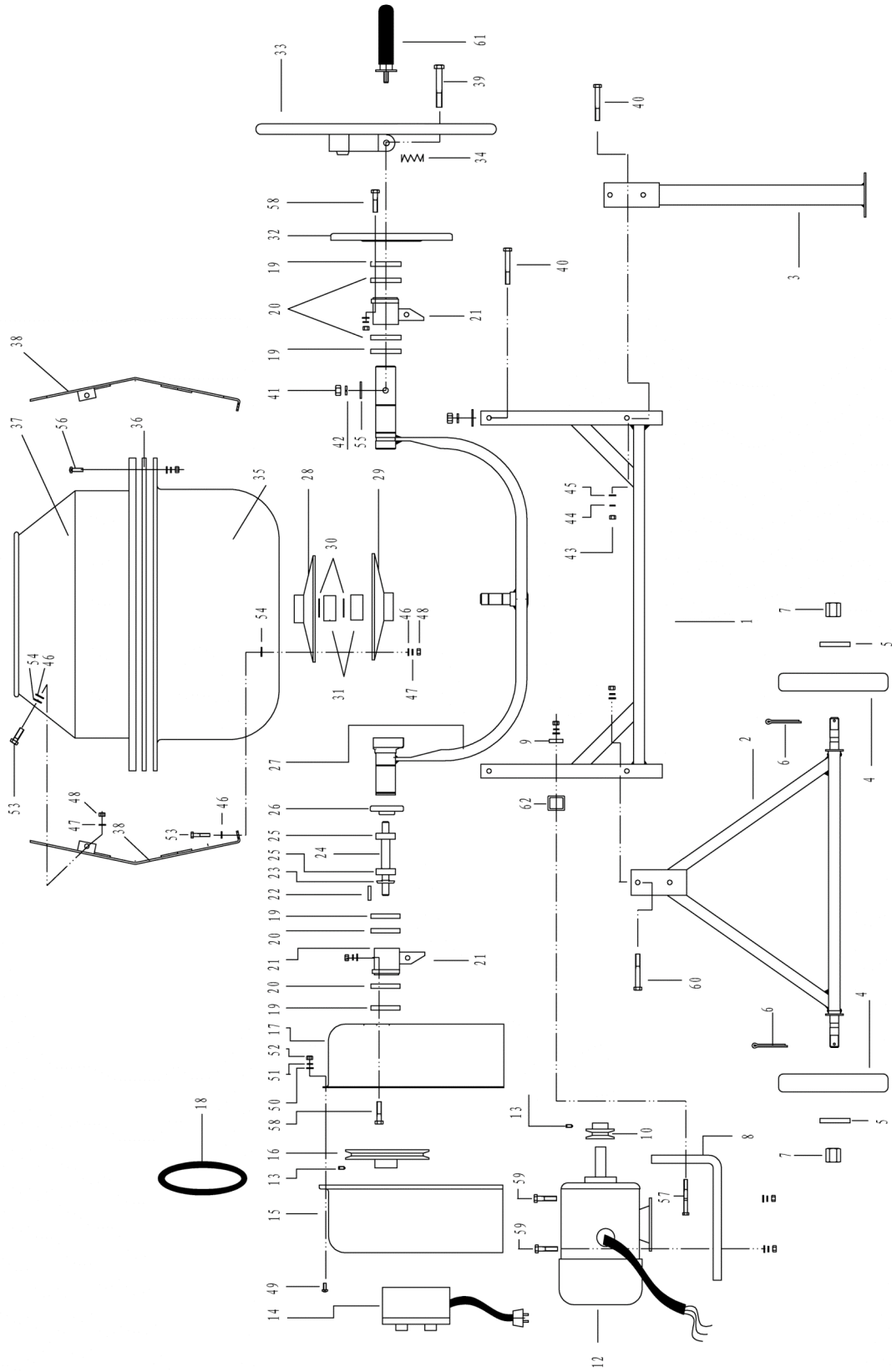

## PARTS LIST

Item	Description	Qty.	Item	Description	Qty.
1	Stand	1	32	Degree Adjusting Plate	1
2	Hinge Bracket	1	33	Degree Adjusting Wheel	1
3	Support Bracket	1	34	Spring	1
4	Wheel	2	35	Lower Drum	1
5	Flat Washer	2	36	Rubber Seal	1
6	Shaft Pin 3 x 30	2	37	Upper Drum	1
7	Lock Nut M16x1.5	2	38	Mixer Blade	2
8	Motor Mount Plate	1	39	Hex Bolt M10x65	1
9	Strap	1	40	Hex Bolt M8x60	4
10	Motor Pulley	1	41	Hex Nut M10	1
			42	Spring Washer 10	1
12	Motor	1	43	Hex Nut M8	14
13	Lock Screw M8 x 8	2	44	Spring Washer 8	14
14	Switch Assembly	1	45	Flat Washer 8	14
15	Outer Motor Cover	1	46	Flat Washer 6	12
16	Pulley	1	47	Spring Washer 6	12
17	Inner Motor Cover	1	48	Hex Nut M6	12
18	Pulley Belt A560mm	1	49	Cross-Head Bolt M5 x 10	3
19	Shaft Pin 38	4	50	Flat Washer 5	3
20	Adjusting Washer	4	51	Spring Washer 5	3
21	Iron Tube Fixture	2	52	Hex Nut M5	3
22	Flat Key 5 x 35	1	53	Cross-Head Bolt M6 x 25	4
23	Dust Cover	1	54	Leather Washer 5	4
24	Shaft	1	55	Flat Washer 10	1
25	Bearing 6002-2RS	2	56	Hex Bolt M6 x 18	6
26	Gear	1	57	Hex Bolt M6 x 50	2
27	Support Arm Assembly	1	58	Hex Bolt M8 x 25	4
28	Bearing Cover , Upper	1	59	Hex Bolt M8 x 20	4
29	Bearing Cover , Lower	1	60	Hex Bolt M8 x 40	2
30	Shaft Pin 20	2	61	Grip Assembly	1
31	Bearing 6204-2RS	2	62	Support Pipe	1



# WARNING

Some dust created by power sanding, sawing, grinding, drilling, and other construction activities contains chemicals known to the State of California to cause cancer, birth defects or other reproductive harm. Some examples of these chemicals are:

- lead from lead-based paints,
- crystalline silica from bricks and cement and other masonry products, and
- arsenic and chromium from chemically-treated lumber.

Your risk from these exposures varies, depending on how often you do this type of work. To reduce your exposure to these chemicals: work in a well ventilated area, and work with approved safety equipment, such as those dust masks that are specially designed to filter out microscopic particles.



Northern Tool + Equipment Co.  
2800 Southcross Drive West  
P.O. Box 1499 Burnsville, MN 55337-0499  
Made in China.