

DIRECT VENT WALL FURNACE

STANDARD MODELS:

HWDV100X(N,P)-1
HWDV150X(N,P)-2

MODELS WITH BLOWER:

HWDV100BX(N,P)-1
HWDV150BX(N,P)-2



INSTALLER:

Leave this manual with the appliance.

CONSUMER:

Retain this manual for future reference.

⚠ WARNING

FIRE OR EXPLOSION HAZARD

If the information in these instructions is not followed exactly, a fire or explosion may result causing property damage, personal injury or loss of life.

- Do not store or use gasoline or other flammable vapors and liquids in the vicinity of this or any other appliance.
- **WHAT TO DO IF YOU SMELL GAS**
 - Do not try to light any appliance.
 - Do not touch any electrical switch; do not use any phone in your building.
 - Leave the building immediately.
 - Immediately call your gas supplier from a neighbor's phone. Follow the gas supplier's instructions.
 - If you cannot reach your gas supplier, call the fire department.
- Installation and service must be performed by a qualified installer, service agency or the gas supplier.

⚠ WARNING

If not installed, operated and maintained in accordance with the manufacturer's instructions, this product could expose you to substances in fuel or from fuel combustion which can cause death or serious illness.

This appliance may be installed in an aftermarket, permanently located, manufactured home (USA only), or mobile home, where not prohibited by state or local codes.

This appliance is only for use with the type of gas indicated on the rating plate. This appliance is not convertible for use with other gases, unless a certified kit is used.

If You Are Missing Parts, Or Have Any Problems, Contact Empire Comfort Systems Inc. At 1 (877) 459-1583.

We Can Assist The Qualified Installer Over The Phone. Do Not Return The Product To The Store Where Purchased Unless Authorized By Empire Comfort Systems.

TABLE OF CONTENTS

SECTION	PAGE
Carton Contents	3
Hardware Packets	4
Tools Needed	5
Gas Specifications	6
Specifications	6
High Altitude Specifications	6
Unit Dimensions	7
Important Safety Information	8 - 10
Safety Information for Users of Propane Gas	11
Introduction	12 - 13
Requirements for Massachusetts	14
Termination Clearances	15
Gas Supply	16 - 17
Clearances	17
Installation Location	18
Installation Overview	19 - 20
Interior Installation	21 - 26
Cutting the Vent Tubes	27 - 28
Exterior Installation of the Venting	29 - 31
Reassembly and Resealing Venting System	32 - 34
Installation of Optional Blower Kit HW125SCB	35 - 38
Before Operating Appliance	39
Operating Instructions	40
Lighting Instructions	41
To Turn Off Gas To Appliance	41
Pilot Flame Characteristics	42
Main Burner Flame Characteristics	42
Maintenance Instructions	43
Troubleshooting	43
Parts List	44
Parts View	45
How To Order Repair Parts	46
Warranty Information	47

CARTON CONTENTS

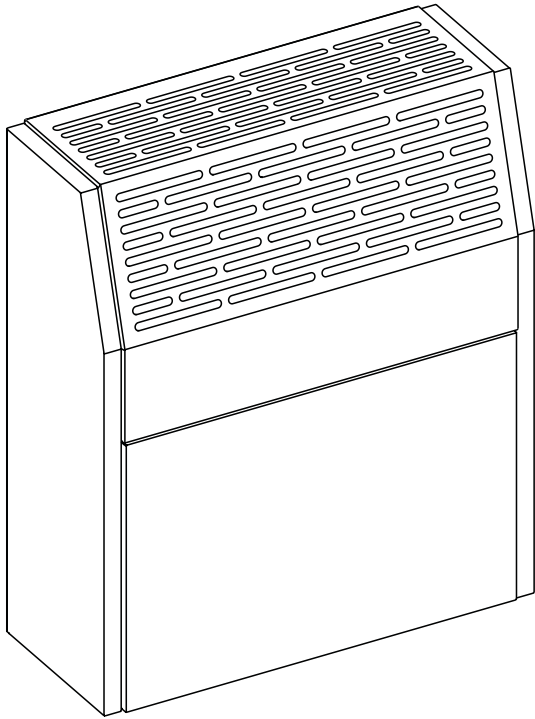

DIRECT VENT HEATER
(INSIDE WALL MOUNTING PLATE
ATTACHED ON BACK)

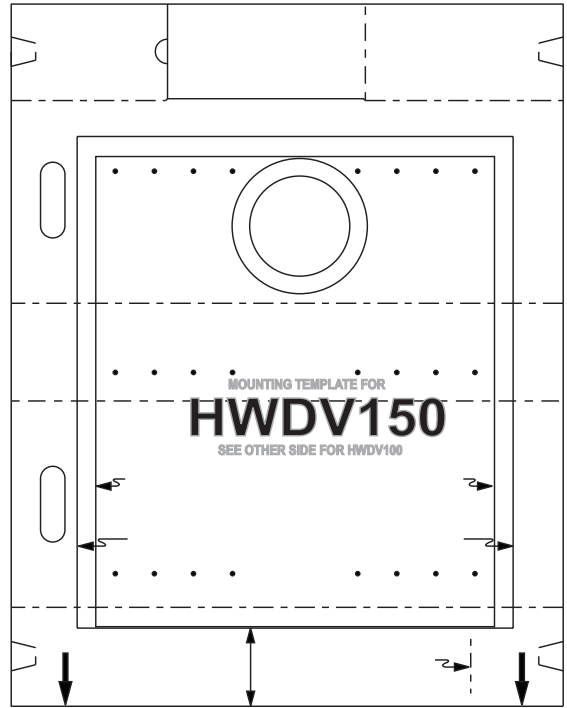

INSTALLATION TEMPLATE
(TEMPLATE FOR HWDV100
ON REVERSE SIDE)



HARDWARE PACKET

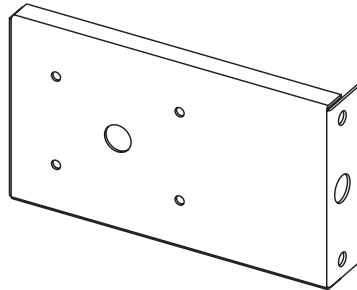

BRACKET* (1)

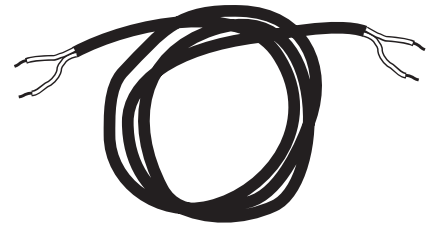

36 INCH WIRE* (1)

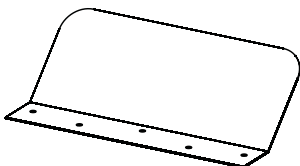

VENT SHIELD

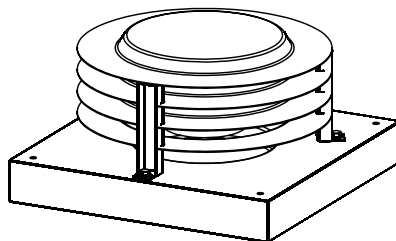

OUTSIDE WALL MOUNTING PLATE
& VENT CAP

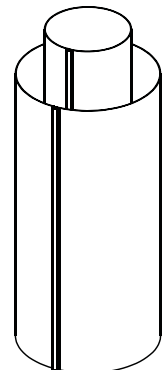

INLET & OUTLET VENT TUBE:

HARDWARE PACKET



NYLON WASHER (2)

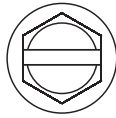

#10 X 1 1/2" SLOTTED HEX HEAD SCREW (6)

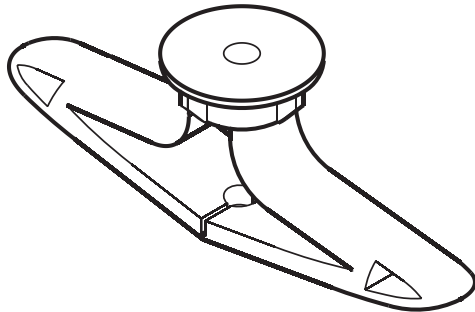
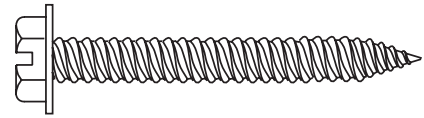

PLASTIC TOGGLE (6)

* Not to scale

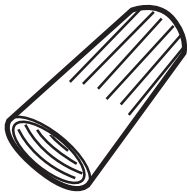

WIRE NUT (1)

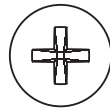

#8 X 3/8" PHILLIPS PAN HEAD SCREW (4)

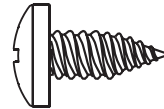

#10 X 1/2" PHILLIPS HEX HEAD SCREW (3)

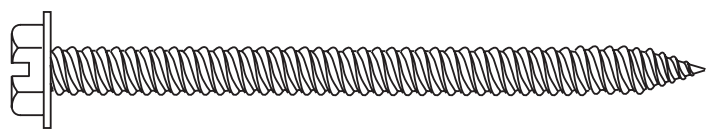
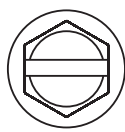
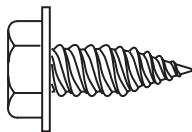

#10 X 2 1/2" HEX HEAD SCREW (4)

TOOLS NEEDED

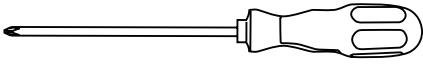

PHILLIPS SCREWDRIVER

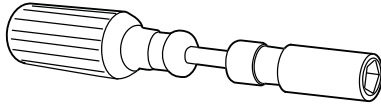

5/16 NUT DRIVER

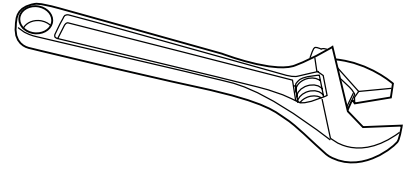

ADJUSTABLE WRENCH

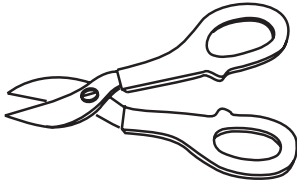

SNIPS



EXTERIOR GRADE
CAULK

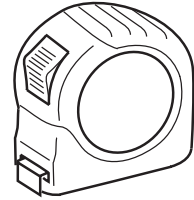

TAPE MEASURE

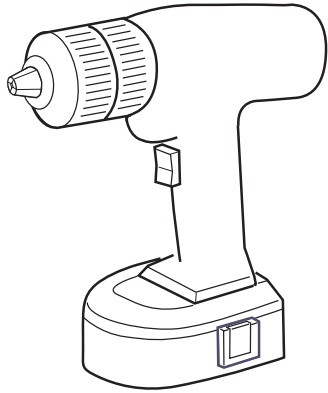

DRILL



FURNACE CEMENT

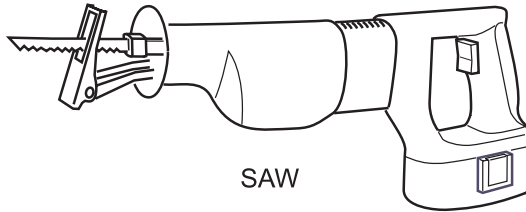

SAW

NOTE: Additional tools may be required depending on the exterior construction materials used on the home.

UNIT OF MEASURE ABBREVIATION LIST	
Abbreviation	Unit
in	Inch
ft	Foot/feet
sq ft	Square foot/feet
mm	Millimeter
m	Meter
sq m	Square meter
lb	Pound
dia	Diameter

GAS SPECIFICATIONS

MODEL	FUEL	INPUT
HWDV100 (X,BX)	Propane - Natural Gas	10,000 Btu/hr
HWDV150 (X,BX)		15,000 Btu/hr
Manifold Pressure	Natural Gas	4.0in W.C.
	Propane Gas	10.0in W.C.
Gas Inlet	1/2 NPT	
Supply	Minimum Pressure	Maximum Pressure
Natural Gas	5in W.C.	10.5in W.C.
Propane Gas	11in W.C.	13in W.C.

NOTE: Appliance input ratings are based on sea level operation and need not be changed for operation up to 2,000 feet (609.6m).

SPECIFICATIONS

MODELS		HWDV100(X,BX)	HWDV150(X,BX)
Combustion		Atmospheric Burner	
Standard Heating Space		233 Sq ft - (21.65 Sq m)	478 Sq ft - (44.41 Sq m)
External Dimensions	Height	21-11/16in - (550.9mm)	25-3/16in - (639.8mm)
	Width	18-5/16in - (465.1mm)	22-5/16in - (566.7mm)
	Depth	9in - (228.6mm)	9-1/2in - (241.3mm)
Net Weight		29 lbs - (13.15 kg)	40 lbs - (18.14 kg)
Max. Gas Consumption		10,000 Btu/hr.	15,000 Btu/hr.
Safety Devices		Safety valve (thermopile)	

NOTE: This direct vent wall furnace is equipped for either Natural or Propane Gas. Field conversion kits are available for purchase by calling 877-459-1583.

CONVERSION KITS		
Part Number	Description	Model
41086	Propane to Natural	HWDV100
41087	Natural to Propane	HWDV100
33467	Propane to Natural	HWDV150
33468	Natural to Propane	HWDV150

UNIT DIMENSIONS

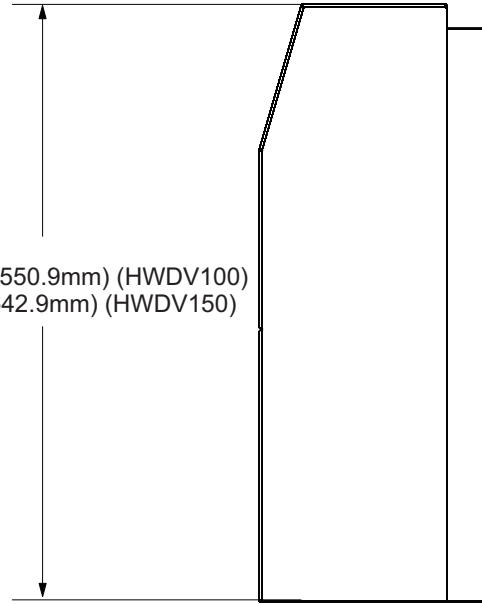
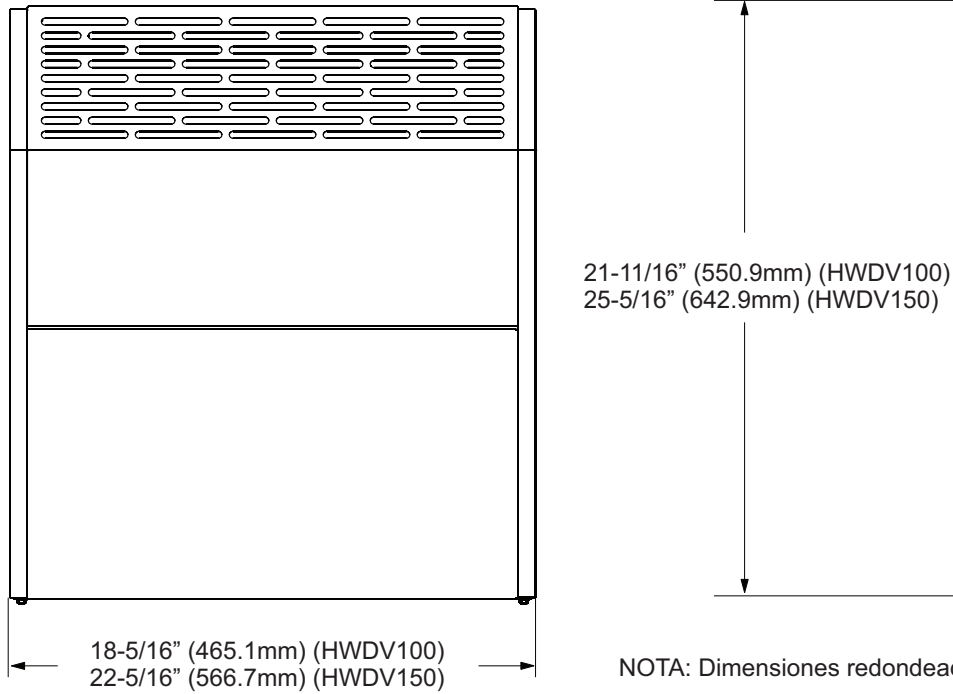
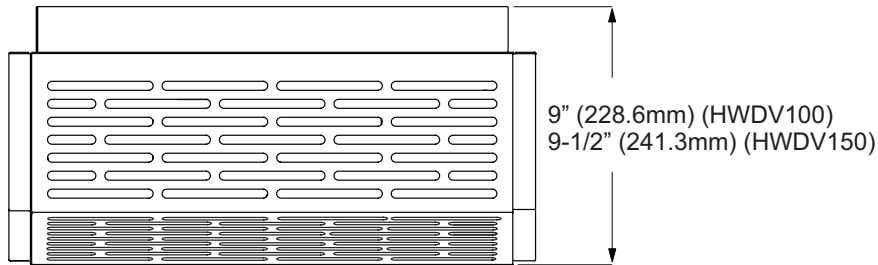

NOTA: Dimensiones redondeadas a 1/16" (1.6 mm) más próxima

**MAKE SURE APPLIANCE IS SUITABLE FOR THE GAS SUPPLY AVAILABLE:
NATURAL GAS OR PROPANE GAS**

IMPORTANT SAFETY INFORMATION

DEFINITIONS:

▲ DANGER: Indicates a hazardous situation which, if not avoided, will result in death or serious injury.

▲ WARNING: Indicates a hazardous situation which, if not avoided, could result in death or serious injury.

▲ CAUTION: Indicates a hazardous situation which, if not avoided, could result in minor or moderate injury.

NOTICE: Addresses practices not related to personal injury.

▲ WARNING: Read and follow these safety precautions prior to operating this heater. Failure to follow these precautions may result in death, injury, or property damage.

SAFETY PRECAUTIONS

- Due to high temperatures, the appliance should be located out of traffic and away from furniture and draperies.
- Alert people – and especially children – to the hazards of high surface temperatures. This heater may become hot enough to burn skin and ignite clothing after prolonged contact. To prevent injury, caution people to stay clear and avoid touching the heater.
- Young children should be carefully supervised when they are in the same room as the appliance.
- The vent cap, located on the outside of your home, will become very hot. Alert everyone, adults and children, to stay clear and avoid touching the vent cap. Keep the area around the vent cap clear of combustibles, including shrubs and trees.
- Keep the area around the heater free of combustible materials – including drapery, upholstered furniture, paper, boxes, and clothing.
- Always keep the appliance area clear and free from combustible material, gasoline and other flammable vapors and liquids.
- This heater requires an unimpeded flow of air to circulate warm air. Do not place objects on or around the heater that may restrict air flow to or from the heater.
- Any safety screen or guard removed to service an appliance must be replaced prior to operating the appliance.

MAINTENANCE PRECAUTIONS

- Installation and repair should be done by a qualified service person. The appliance should be inspected before use and at least annually by a qualified service person. More frequent cleaning may be required due to excessive lint from carpeting, bedding material, etc. It is imperative that control compartments, burners and circulating air passageways of the appliance be kept clean.
- Pilot hole cover must be kept tightly closed during operation.

DAMAGED HEATER

- Do not use this appliance if any part has been under water. Immediately call a qualified service technician to inspect the appliance and to replace any part of the control system and any gas control which has been under water.
- In the event of a natural disaster (tornado, earthquake, fire, etc.) have a qualified technician inspect the heater for damage or potential gas leaks. Repair or replace any damaged components before operating this heater.

IMPORTANT SAFETY INFORMATION

⚠ WARNING: Any change to this furnace or its control can be dangerous. This is a heating appliance and any panel, door or guard removed for servicing an appliance must be replaced prior to operating the appliance.

1

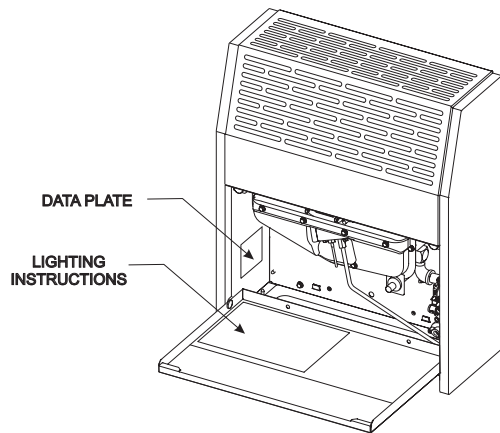

Do not use gases other than those indicated on the heater's data plate label.

2

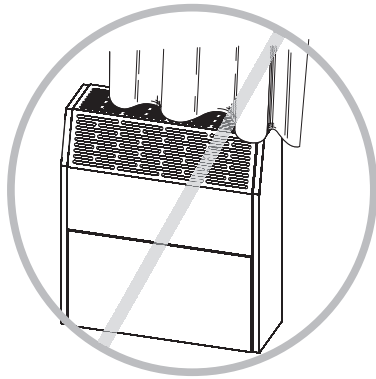

Due to high temperature, the appliances should be located out of traffic and away from furniture and draperies.

3

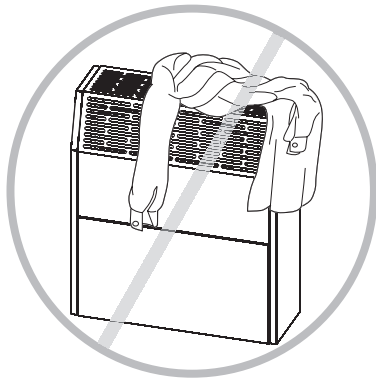

Do not place clothing or other flammable material on or near the appliance. Do not dry clothes over heater. Blockage of hot air outlet will cause overheating of appliance, and possible fire.

4

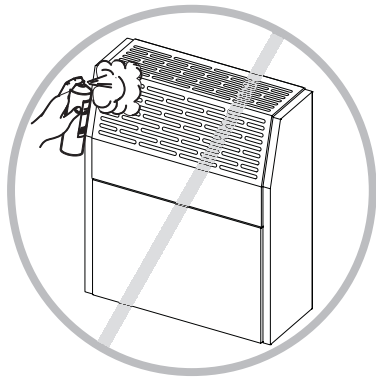

Do not spray any aerosol near heater when in operation. Do not store these elements near appliance.

IMPORTANT SAFETY INFORMATION

5

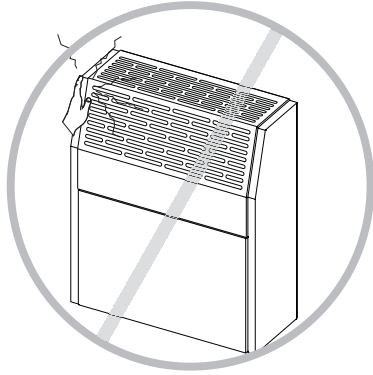

To avoid burning yourself, do not touch louvers while operating the heater.

6

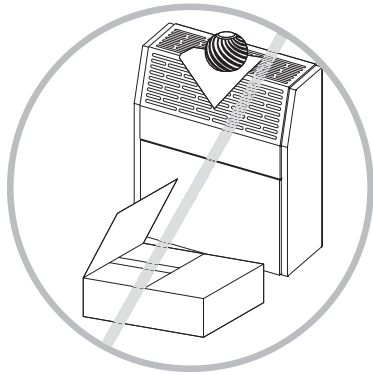

Do not block air inlet and hot air outlet.

7

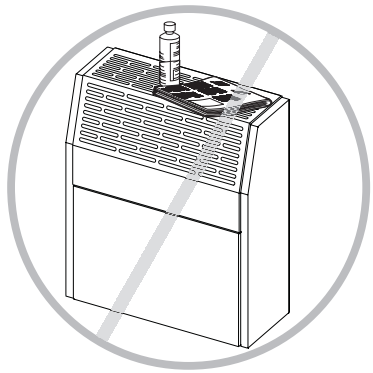

Do not place flammable elements on or near the heater.

SAFETY INFORMATION FOR USERS OF PROPANE GAS

Propane is a flammable gas which can cause fires and explosions. In its natural state, propane is odorless and colorless. You may not know all the following safety precautions which can protect both you and your family from an accident. Read them carefully now, then review them point by point with the members of your household. Someday when there may not be a minute to lose, everyone's safety will depend on knowing exactly what to do. If, after reading the following information, you feel you still need more information, please contact your gas supplier.

▲ PROPANE GAS ODOR WARNING:

If a gas leak happens, you should be able to smell the gas because of the odorant put in the Propane Gas. That's your signal to go into immediate action!

- Do not operate electric switches, light matches, use your phone. Do not do anything that could ignite the gas.
- Get everyone out of the building, vehicle, trailer, or area. Do that **IMMEDIATELY**.
- Close all gas tank or cylinder supply valves.
- Propane Gas is heavier than air and may settle in low areas such as basements. When you have reason to suspect a gas leak, keep out of basements and other low areas. Stay out until firefighters declare them to be safe.
- Use your neighbor's phone and call a trained Propane Gas service person and the fire department. Even though you may not continue to smell gas, do not turn on the gas again. Do not re-enter the building, vehicle, trailer, or area.
- **Finally**, let the service man and firefighters check for escaped gas. Have them air out the area before you return. Properly trained Propane Gas service people should repair the leak, then check and relight the gas appliance for you.

NO ODOR DETECTED - ODOR FADE

Some people cannot smell well. Some people cannot smell the odor of the chemical put into the gas. You must find out if you can smell the odorant in propane. Smoking can decrease your ability to smell. Being around an odor for a time can affect your sensitivity or ability to detect that odor. Sometimes other odors in the area mask the gas odor. People may not smell the gas odor or their minds are on something else. Thinking about smelling a gas odor can make it easier to smell.

The odorant in Propane Gas is colorless, and it can fade under some circumstances. For example, if there is an underground leak, the movement of the gas through soil can filter the odorant. Odorants in Propane Gas also are subject to oxidation. This fading can occur if there is rust inside the storage tank or in iron gas pipes.

The odorant in escaped gas can adsorb or absorb onto or into walls, masonry and other materials and fabrics in a room. That will take some of the odorant out of the gas, reducing its odor intensity.

Propane Gas may stratify in a closed area, and the odor intensity could vary at different levels. Since it is heavier than air, there may be more odor at lower levels. Always be sensitive to the slightest gas odor. If you detect any odor, treat it as a serious leak. Immediately go into action as instructed earlier.

SOME POINTS TO REMEMBER

- Learn to recognize the odor of Propane Gas. Your local Propane Gas Dealer can give you a "Scratch and Sniff" pamphlet. Use it to find out what the propane odor smells like. If you suspect that your Propane Gas has a weak or abnormal odor, call your Propane Gas Dealer.
- If you are not qualified, do not light pilot lights, perform service, or make adjustments to appliances on the Propane Gas system. If you are qualified, consciously think about the odor of Propane Gas prior to and while lighting pilot lights or performing service or making adjustments.
- Sometimes a basement or a closed-up house has a musty smell that can cover up the Propane Gas odor. Do not try to light pilot lights, perform service, or make adjustments in an area where the conditions are such that you may not detect the odor if there has been a leak of Propane Gas.
- Odor fade, due to oxidation by rust or adsorption on walls of new cylinders and tanks, is possible. Therefore, people should be particularly alert and careful when new tanks or cylinders are placed in service. Odor fade can occur in new tanks, or reinstalled old tanks, if they are filled and allowed to set too long before refilling. Cylinders and tanks which have been out of service for a time may develop internal rust which will cause odor fade. If such conditions are suspected to exist, a periodic sniff test of the gas is advisable. If you have any question about the gas odor, call your Propane Gas dealer. A periodic sniff test of the Propane Gas is a good safety measure under any condition.
- If, at any time, you do not smell the Propane Gas odorant and you think you should, assume you have a leak. Then take the same immediate action recommended above for the occasion when you do detect the odorized Propane Gas.
- If you experience a complete "gas out," (the container is under no vapor pressure), turn the tank valve off immediately. If the container valve is left on, the container may draw in some air through openings such as pilot light orifices. If this occurs, some new internal rusting could occur. If the valve is left open, then treat the container as a new tank. Always be sure your container is under vapor pressure by turning it off at the container before it goes completely empty or having it refilled before it is completely empty.

INTRODUCTION

Always consult your local Building Department regarding regulations, codes or ordinances which apply to the installation of a direct vent wall furnace.

Instructions to Installer

1. Installer must leave instruction manual with owner after installation.
2. Installer must have owner fill out and mail warranty card supplied with furnace.
3. Installer should show owner how to start and operate furnace.

⚠ WARNING

Any change to this furnace or its control can be dangerous. This is a heating appliance and any panel, door or guard removed for servicing an appliance must be replaced prior to operating the appliance.

General Information

This furnace is design certified in accordance with American National Standard/CSA Standard Z21.86 and CSA 2.32 by Underwriters Laboratory as a direct vent wall furnace to be installed according to these instructions.

Any alteration of the original design, installed other than as shown in these instructions or use with a type of gas not shown on the rating plate is the responsibility of the person and company making the change.

Notice: During initial firing of this unit, its paint will bake out and smoke will occur. To prevent triggering of smoke alarms, ventilate the room in which the unit is installed.

Installation in Residential Garages

Gas utilization equipment in residential garages shall be installed so that all burners and burner ignition devices are located not less than 18in (457.2mm) above the floor. Such equipment shall be located, or protected, so it is not subject to physical damage by a moving vehicle.

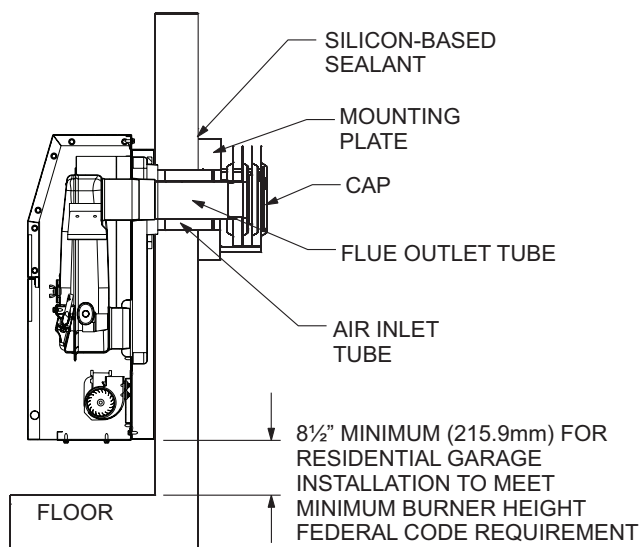

Figure 1

Qualified Installing Agency

Installation and replacement of gas piping, gas utilization equipment or accessories and repair and servicing of equipment shall be performed by a qualified agency. The term "qualified agency" means any individual, firm, corporation or company which either in person or through a representative is engaged in and is responsible for (1) the installation or replacement of gas piping or (2) the connection, installation, repair or servicing of equipment, who is experienced in such work, familiar with all precautions required and has complied with all the requirements of the authority having jurisdiction.

Commonwealth of Massachusetts: The installation must be made by a licensed plumber or gas fitter in the Commonwealth of Massachusetts. The state of Massachusetts requires that a flexible appliance connector cannot exceed 3ft (914.4mm) in length.

The installation must conform with local codes or, in the absence of local codes, with the *National Fuel Gas Code ANSI Z223.1/NFPA 54* Natural Gas and Propane Installation Code, CSA B149.1*.

*Available from the American National Standards Institute, Inc., 11 West 42nd St., New York, N.Y. 10036.

- The vent terminal for HWDV100 models shall be located at least 6in (150mm) from any air opening into a building.
- The vent terminal for HWDV150 models shall be located at least 9in (228.6mm) from any air opening into a building.
- The bottom of the vent terminal on all models shall be located at least 12in (304.8mm) above grade. See termination clearance chart on page 14.

⚠ WARNING

The nearest point of the vent cap should be a minimum horizontal distance of 6ft (1.83m) from any pressure regulator. In case of regulator malfunction, the 6ft (1.83m) distance will reduce the chance of gas entering the vent cap.

Well Head Gas Installations

Some Natural Gas utilities use "well head" gas. This may affect the BTU output of the unit and promote sooting. Units shall not be converted to use well head gas.

This appliance is only for use with the type of gas indicated on the rating plate. This appliance is not convertible for use with other gases.

INTRODUCTION (CONT'D)

When an existing Category 1 heater is removed or replaced, the original venting system may no longer be sized to properly vent the attached appliances. Instructions shall also indicate effects of an improperly sized venting system (formation of condensate, leakage, spillage, etc.) and shall specify the following test procedure:

WARNING

CARBON MONOXIDE POISONING HAZARD

Failure to follow the steps outlined below for each appliance connected to the venting system being placed into operation could result in carbon monoxide poisoning or death. The following steps shall be followed for each appliance connected to the venting system being placed into operation, while all other appliances connected to the venting system are not in operation:

1. Seal any unused openings in the venting system.
2. Inspect the venting system for proper size and horizontal pitch, as required in the National Fuel Gas Code, ANSI Z223.1/NFPA 54 or the Natural Gas and Propane Installation Code, CSA B149.1 and these instructions. Determine that there is no blockage or restriction, leakage, corrosion and other deficiencies which could cause an unsafe condition.
3. As far as practical, close all building doors and windows and all doors between the space in which the appliance(s) connected to the venting system are located and other spaces of the building.
4. Close fireplace dampers.
5. Turn on clothes dryers and any appliance not connected to the venting system. Turn on any exhaust fans, such as range hoods and bathroom exhausts, so they are operating at maximum speed. Do operate a summer exhaust fan.
6. Follow the lighting instructions. Place the appliance being inspected into operation. Adjust the thermostat so appliance is operating continuously.
7. Test for spillage from draft hood equipped appliances at the draft hood relief opening after 5 minutes of main burner operation. Use the flame of a match or candle.
8. If improper venting is observed during any of the above tests, the venting system must be corrected in accordance with National Fuel Gas Code, ANSI Z223.1/NFPA 54 and/or Natural Gas and Propane Installation Code, CSA B149.1.
9. After it has been determined that each appliance connected to the venting system properly vents when tested as outlined above, return doors, windows, exhaust fans, fireplace dampers and any other gas-fired burning appliance to their previous conditions of use.

REQUIREMENTS FOR MASSACHUSETTS

For all side wall horizontally vented gas fueled equipment installed in every dwelling, building or structure used in whole or in part for residential purposes, including those owned or operated by the Commonwealth and where the side wall exhaust vent termination is less than seven feet above finished grade in the area of the venting, including but not limited to decks and porches, the following requirements shall be satisfied:

1. **INSTALLATION OF CARBON MONOXIDE DETECTORS.**
At the time of installation of the side wall horizontal vented gas fueled equipment, the installing plumber or gasfitter shall observe that a hard wired carbon monoxide detector with an alarm and battery back-up is installed on the floor level where the gas equipment is to be installed. In addition, the installing plumber or gasfitter shall observe that a battery operated or hard wired carbon monoxide detector with an alarm is installed on each additional level of the dwelling, building or structure served by the side wall horizontal vented gas fueled equipment. It shall be the responsibility of the property owner to secure the services of qualified licensed professionals for the installation of hard wired carbon monoxide detectors.
 - (a) In the event that the side wall horizontally vented gas fueled equipment is installed in a crawl space or an attic, the hard wired carbon monoxide detector with alarm and battery back-up may be installed on the next adjacent floor level.
 - (b) In the event that the requirements of this subdivision can not be met at the time of completion of installation, the owner shall have a period of thirty days to comply with the above requirements; provided, however, that during said thirty day period, a battery operated carbon monoxide detector with an alarm shall be installed.
2. **APPROVED CARBON MONOXIDE DETECTORS.** Each carbon monoxide detector as required in accordance with the above provisions shall comply with NFPA 720 and be ANSI/UL 2034 listed and IAS certified.
3. **SIGNAGE.** A metal or plastic identification plate shall be permanently mounted to the exterior of the building at a minimum height of eight feet above grade directly in line with the exhaust vent terminal for the horizontally vented gas fueled heating appliance or equipment. The sign shall read, in print size no less than one-half (1/2) inch in size, **“GAS VENT DIRECTLY BELOW. KEEP CLEAR OF ALL OBSTRUCTIONS”**.
4. **INSPECTION.** The state or local gas inspector of the side wall horizontally vented gas fueled equipment shall not approve the installation unless, upon inspection, the inspector observes carbon monoxide detectors and signage installed in accordance with the provisions of 248 CMR 5.08(2)(a) 1 through 4.
 - (b) **EXEMPTIONS:** The following equipment is exempt from 248 CMR 5.08(2)(a)1 through 4:
 1. The equipment listed in Chapter 10 entitled “Equipment Not Required To Be Vented” in the most current edition of NFPA 54 as adopted by the Board; and
 2. Product Approved side wall horizontally vented gas fueled equipment installed in a room or structure separate from the dwelling, building or structure used in whole or in part for residential purposes.
 - (c) **MANUFACTURER REQUIREMENTS - GAS EQUIPMENT VENTING SYSTEM PROVIDED.** When the manufacturer of Product Approved side wall horizontally vented gas equipment provides a venting system design or venting system components with the equipment, the instructions provided by the manufacturer for installation of the equipment and the venting system shall include:
 1. Detailed instructions for the installation of the venting system design or the venting system components; and
 2. A complete parts list for the venting system design or venting system.
 - (e) A copy of all installation instructions for all Product Approved side wall horizontally vented gas fueled equipment, all venting instructions, all parts lists for venting instructions, and/or all venting design instructions shall remain with the appliance or equipment at the completion of the installation.

TERMINATION CLEARANCES

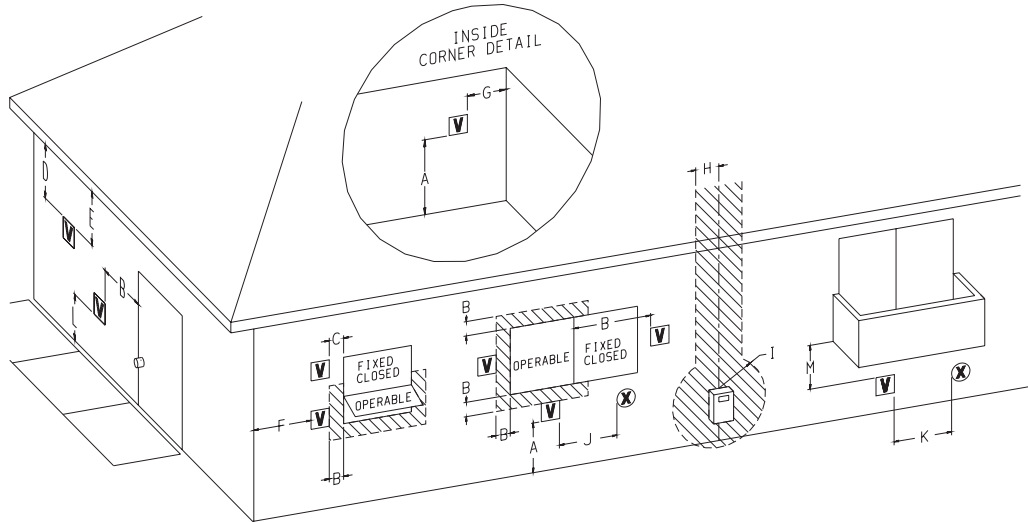

V VENT TERMINAL

X AIR SUPPLY INLET

Hatched Area AREA WHERE TERMINAL IS NOT PERMITTED

	Canadian Installations ¹	US Installations ²
A= Clearance above grade, veranda, porch, deck, or balcony	12 in (30 cm)	12 in (30 cm)
B= Clearance to window or door that may be open	6 in (15 cm) for appliances ≤ 10,000 Btuh (3 kW), 12 in (30 cm) for appliances > 10,000 Btuh (3 kW) and ≤ 100,000 Btuh (30 kW), 36 in (91 cm) for appliances > 100,000 Btuh (30 kW)	6 in (15 cm) for appliances ≤ 10,000 Btuh (3 kW), 9 in (23 cm) for appliances > 10,000 Btuh (3 kW) and ≤ 50,000 Btuh (15 kW), 12 in (30 cm) for appliances > 50,000 Btuh (15 kW)
C= Clearance to permanently closed window	*	9in
D= Vertical clearance ventilated soffit located above the terminal within a horizontal distance of 2 feet (61 cm) from the center line of the terminal	*	24in
E= Clearance to unventilated soffit	*	18in
F= Clearance to outside corner	*	24in
G= Clearance inside corner	*	24in
H= Clearance to each side of center line extended above meter/regulator assembly	3 ft (91 cm) within a height 15 ft (4.5 m) above the meter/regulator assembly	6ft

	Canadian Installations ¹	US Installations ²
I= Clearance to service regulator vent outlet	3 ft (91 cm)	6ft
J= Clearance to nonmechanical air supply inlet to building or the combustion air inlet to any other appliance	6 in (15 cm) for appliances ≤ 10,000 Btuh (3 kW), 12 in (30 cm) for appliances > 10,000 Btuh (3 kW) and ≤ 100,000 Btuh (30 kW), 36 in (91 cm) for appliances > 100,000 Btuh (30 kW)	6 in (15 cm) for appliances ≤ 10,000 Btuh (3 kW), 9 in (23 cm) for appliances > 10,000 Btuh (3 kW) and ≤ 50,000 Btuh (15 kW), 12 in (30 cm) for appliances > 50,000 Btuh (15 kW)
K= Clearance to a mechanical air supply inlet	6 ft (1.83 m)	3 ft (91 cm) above if within 10 ft (3 m) horizontally
L= Clearance above paved sidewalk or paved driveway located on public property	7 ft (2.13 m) †	7ft
M= Clearance under veranda, porch deck, or balcony	12 in (30 cm) ‡	12in

1 In accordance with the current CSA B149.1, Natural Gas and Propane Installation Code

2 In Accordance with the current ANZI Z223.1/NFPA 54, National Fuel Gas Code

† A vent shall not terminate directly above a sidewalk or paved driveway that is located between two single family dwellings and serves both dwellings

‡ Permitted only if veranda, porch, deck, or balcony is fully open on a minimum of two sides beneath the floor.

* For clearances not specified in ANZI Z223.1/NFPA 54 or CSA B149.1, one of the following shall be indicated:

a) A minimum clearance value determined by testing in accordance with section 2.23.5, or;

b) A reference to the following footnote: "Clearance in accordance with local installation codes and the requirements of the gas supplier."

GAS SUPPLY

Locating Gas Supply

The gas line can enter the unit either through the floor or outside wall. The gas line opening should be made at this time. Location of the opening will be determined by the position of floor joists and the valve and union used for servicing.

RECOMMENDED GAS PIPE DIAMETER				
Pipe Length	Schedule 40 Pipe Inside Diameter		Tubing, Type L Outside Diameter	
	Natural	Propane	Natural	Propane
0-10 feet 0-3 meters	1/2in 12.7 mm	3/8in 9.5mm	1/2in 12.7 mm	3/8in 9.5 mm
10-40 feet 4-12 meters	1/2in 12.7 mm	1/2in 12.7mm	5/8in 15.9 mm	1/2in 12.7 mm
40-100 feet 13-30 meters	1/2in 12.7 mm	1/2in 12.7mm	3/4in 19 mm	1/2in 12.7 mm
100-150 feet 31-46 meters	3/4in 19 mm	1/2in 12.7 mm	7/8in 22.2 mm	3/4in 19 mm

NOTE: Never use plastic pipe. Check to confirm whether your local codes allow copper tubing or galvanized.

NOTE: Since some municipalities have additional local codes, it is always best to consult your local authority and installation code.

The use of the following gas connectors is recommended:

- ANSI Z21.24 Appliance Connectors of Corrugated Metal Tubing and Fittings
- ANSI Z21.45 Assembled Flexible Appliance Connectors of Other Than All-Metal Construction

The above connectors may be used if acceptable by the authority having jurisdiction. The Commonwealth of Massachusetts requires that a flexible appliance connector cannot exceed 3ft (914.4mm) in length.

Consult the current National Fuel Gas Code, ANSI Z223.1 CAN/CGA-B149 (.1 or .2) installation code.

Installing a Shut-Off Valve

Each appliance should have its own shut-off valve.

A shut-off valve should be located in the vicinity of the unit. Where none exists, or where its size or location is not adequate, contact your local authorized installer for installation or relocation.

Compounds used on threaded joints of gas piping shall be resistant to the action of liquefied petroleum gases. The gas lines must be checked for leaks by the installer. This should be done with a soap solution watching for bubbles on all exposed connections, and if unexposed, a pressure test should be made.

Never use an exposed flame to check for leaks. Appliance must be disconnected from piping at inlet of control valve and pipe capped or plugged for pressure test. Never pressure test with appliance connected; control valve will sustain damage!

A gas valve and ground joint union should be installed in the gas line upstream of the gas control to aid in servicing. It is required by the National Fuel Gas Code that a drip leg be installed near the gas inlet. **See Figure 2.** This should consist of a vertical length of pipe tee connected into the gas line that is capped on the bottom in which condensation and foreign particles may collect.

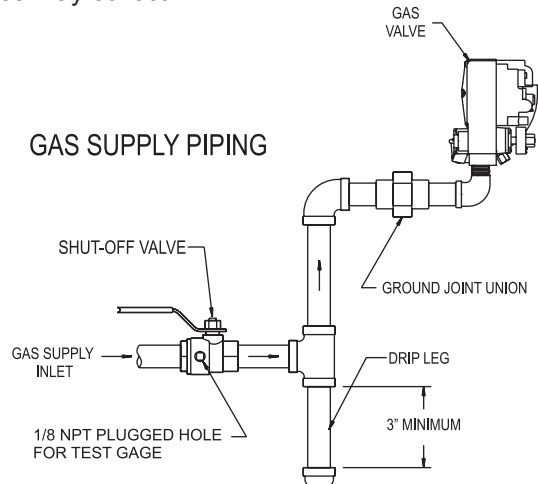
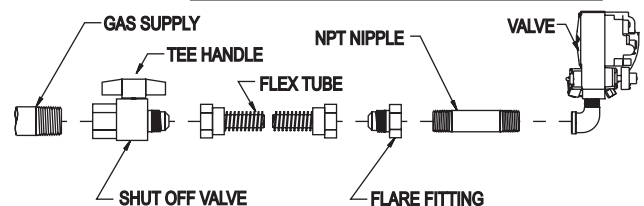

Figure 2

Method of Installing a Tee Fitting Sediment Trap

FLEXIBLE GAS LINE CONNECTION



RIGID GAS LINE CONNECTION

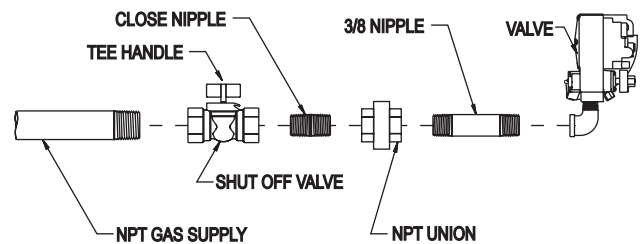

Figure 3

CAUTION

Since some leak test solutions, including soapy water, may cause corrosion or stress cracking, all tested pipes and joints shall be rinsed in water, unless it has been determined that the test solution is a non-corrosive type.

GAS SUPPLY (CONT'D)

Pressure Testing of the Gas Supply System

1. To check the inlet pressure to the gas valve, a 1/8in (3.2mm) N.P.T. plugged tapping, accessible for test gauge connection, must be placed immediately upstream of the gas supply connection to the appliance.
2. The appliance and its individual shut-off valve must be disconnected from the gas supply piping system during any pressure testing of that system at test pressures in excess of 1/2 psig (3.5 kPa).
3. The appliance must be isolated from the gas supply piping system by closing its individual shut-off valve during any pressure testing of the gas supply piping system at test pressures equal to or less than 1/2 psig (3.5 kPa).

Checking Manifold Pressure

Both Propane and Natural Gas have built-in pressure regulators in the gas valve. Natural Gas models will have a manifold pressure of approximately 4.0in w.c. (.996 kPa) at the valve outlet with the inlet pressure to the valve from a minimum of 5.0in w.c. (1.245 kPa) for the purpose of input adjustment to a maximum of 10.5in w.c. (2.61 kPa). Propane Gas models will have a manifold pressure approximately 10.0in w.c. (2.49 kPa) at the valve outlet with the inlet pressure to the valve from a minimum of 11.0in w.c. (2.739 kPa) for the purpose of input adjustment to a maximum of 13.0in w.c. (3.237 kPa).

WARNING

If one of the above procedures results in pressures in excess of 1/2 psig (14in w.c.) (3.5 kPa) on the appliance gas valve, it will result in a hazardous condition.

CLEARANCES

1. In selecting a location for installation, it is necessary to provide adequate accessibility clearances for servicing and proper installation.
2. Unit is supported by a wall bracket secured to the wall.
3. The minimum clearances from casing to combustible construction is 36in (914.4mm) on top, 6in (152.4mm) on each side and 4in (101.6mm) from the floor or from the top surface of carpeting, tile or other floor covering and 0in (0mm) to rear wall.
4. The minimum distance from the center of the vent cap to the nearest outside corner or obstruction is 24in (609.6mm).
5. The minimum wall depth is 4-1/2in (114.3mm) and the maximum is 12in (304.8mm). The use of tubes not supplied by the manufacturer results in unsatisfactory performance.

WARNING

The nearest point of the vent cap should be a minimum horizontal distance of 6ft (1.83m) from any pressure regulator. In case of regulator malfunction, the six foot distance will reduce the chance of gas entering the vent cap.

INSTALLATION LOCATION

Location - All Models

Select a location near the center of the space to be heated. The heat will circulate through doorways into adjacent rooms.

Install the furnace on an outside wall. Locate wall studs so that wall opening will be located between wall studs. One wall stud can be used for attachment of inside wall plate. The wall opening required as shown in **Figure 4** is a minimum diameter of 6-1/4in (158.8mm). The wall mounting plate will cover a maximum wall opening of 7in (177.8mm) diameter. A template is provided in furnace carton for positioning furnace on the wall. Also, refer to **Figure 4** for positioning the furnace on wall and for locating gas line connection.

For large homes or spread-out floor plans, two or more furnaces are recommended.

Do not locate furnace where a door could block the heated air flow. **See Figure 5.**

Do not install in a closet, alcove or small hallway where the furnace could be isolated by closing doors to the heated space. **See Figures 6 and 7.**

Do not block air circulation of furnace.

When location is selected, check the walls to make sure there are no obstructions such as pipes, electric wiring, etc., which would interfere with the installation of the furnace or vent pipe.

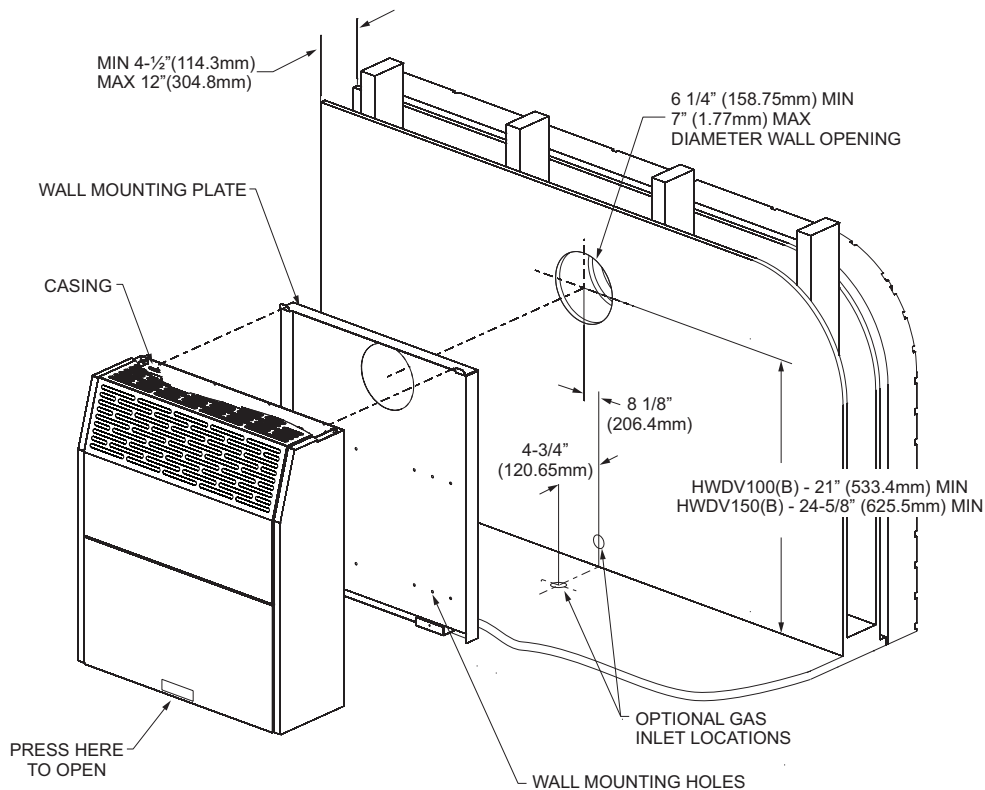

Figure 4

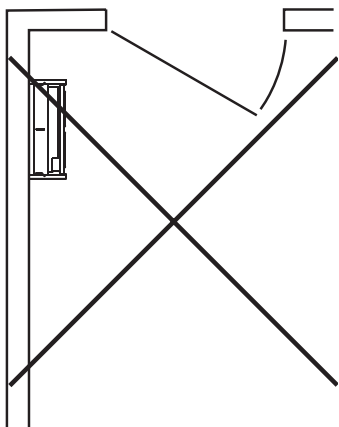

Figure 5

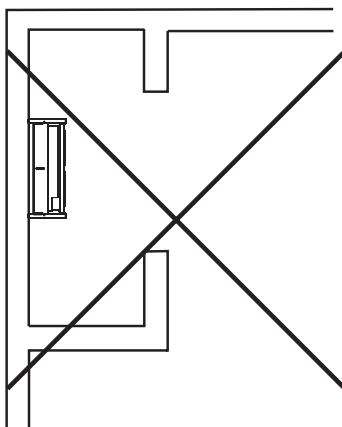

Figure 6

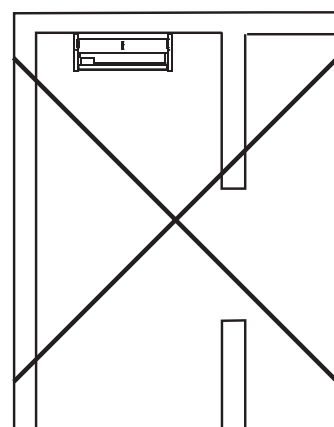

Figure 7

INSTALLATION OVERVIEW

⚠ WARNING: Any change to this heater or its control can be dangerous.

⚠ WARNING: Provide adequate clearances and accessibility for purposes of servicing and proper operation.

A manufactured home (USA only) installation must conform with the Manufactured Home Construction and Safety Standard, Title 24 CFR, Part 3280 or, when such standard is not applicable, the Standard for Manufactured Home Installations, ANSI Z225.1.

⚠ WARNING: Due to high surface temperature, keep children, clothing, and furniture away. Keep burner and control compartments clean.

INSTALLATION OVERVIEW

⚠ WARNING: Improper installation, adjustments, alteration, service, or maintenance can cause property damage, personal injury or loss of life.

Installation and service must be performed by a qualified installer, service agency, or the gas supplier.

These wall furnace models are designed for direct venting through a wall. Only venting components approved for these furnaces may be used.

This unit is to be installed on a wall from 4-1/2in to 12in (114.3mm to 304.8mm) thick.

NOTE: All references must be considered as if the observer is standing in front of the wall and/or appliance.

1

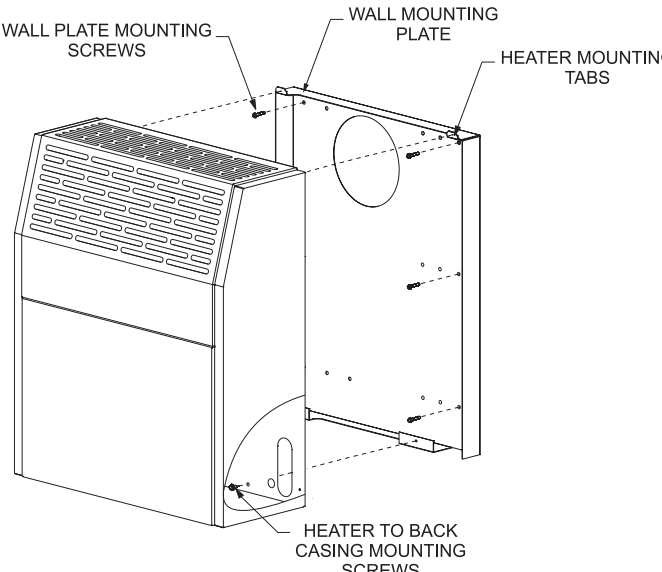

Mark the venting system hole location (as indicated on page 21, box 4) and the six holes through the wall mounting plate. Drill accordingly. Insert the four wall anchors provided and tighten the wall mounting plate firmly. Use special anchor fasteners if the heater is to be installed on a wooden (hollow) wall. Line up the two tabs on the top of the wall mounting plate with the holes in the back of the unit. Slide the back of the unit onto the tabs of the wall mounting plate. Secure the back of the unit into place using two screws. Replace casing door. The heater is now ready to receive the venting system assembly from the opposite side of the wall.

NOTE: All references must be considered as if the observer is standing in front of the wall and/or appliance.

IMPORTANT: The venting system must be properly installed to ensure proper and safe operation. The venting system must also be properly re-installed and re-sealed to ensure proper and safe operation.

INSTALLATION OVERVIEW (CONT'D)

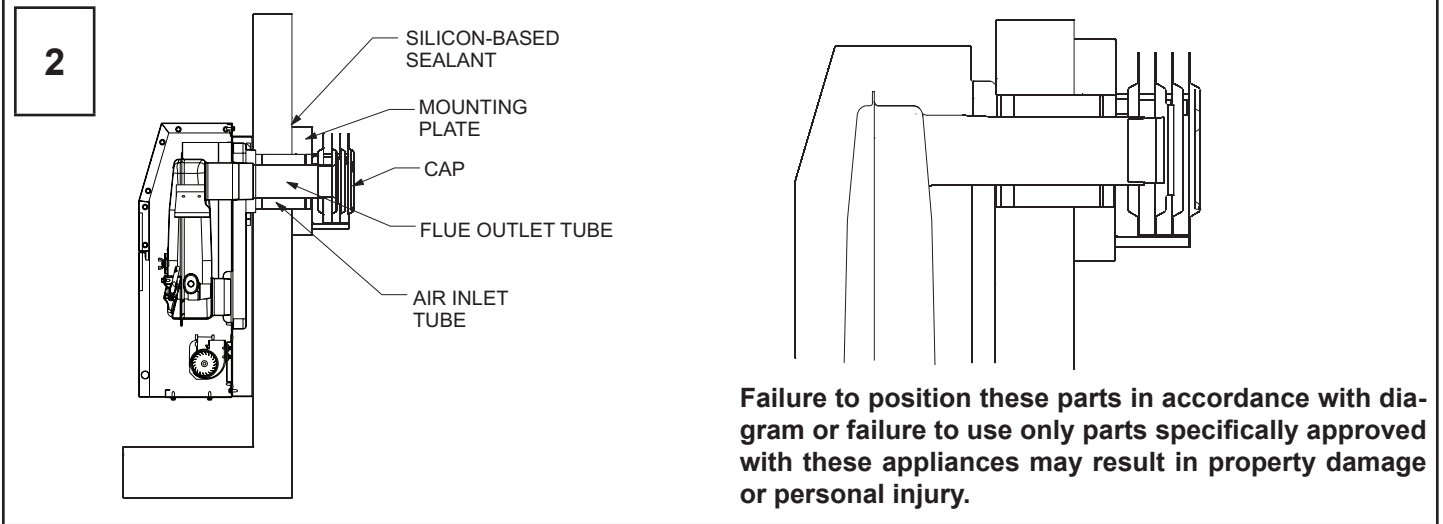

INSTALLATION OF HOUSEWARMER PRODUCT

ATTENTION! INSTALLATION AND ANY REPAIRS TO THIS APPLIANCE MUST BE DONE BY A QUALIFIED SERVICE PERSON.

⚠ WARNING: Read the installation instructions thoroughly before cutting or drilling any holes for installation.

⚠ WARNING: Do not remove any rating plates attached to the appliance.

A qualified service person should be called to inspect this appliance annually.
Have all of your appliances checked annually.

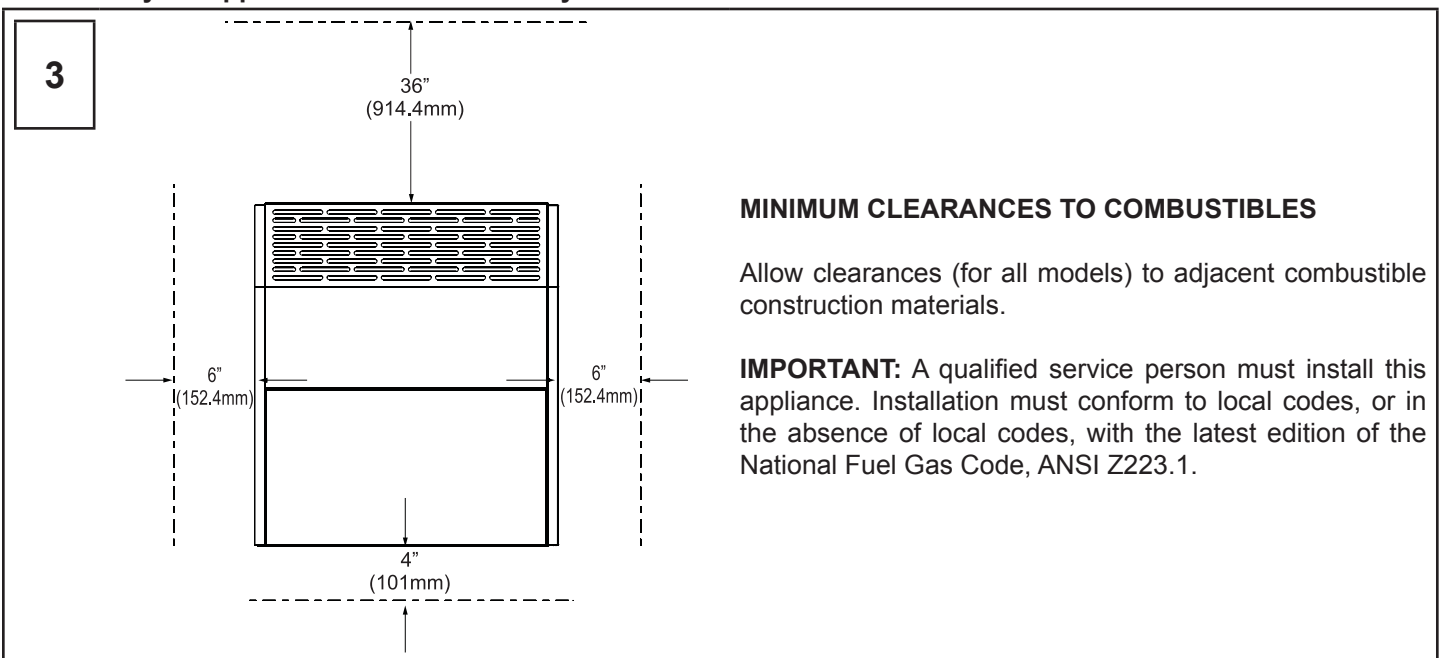

INTERIOR INSTALLATION

1

Housewarmer recommends the use of the wall template to properly cut the wall holes and place the heater. If the template is damaged or not included, refer to the table and graphic below for proper alignment of the wall openings and heater. Be sure the baseboard does not get in the way.

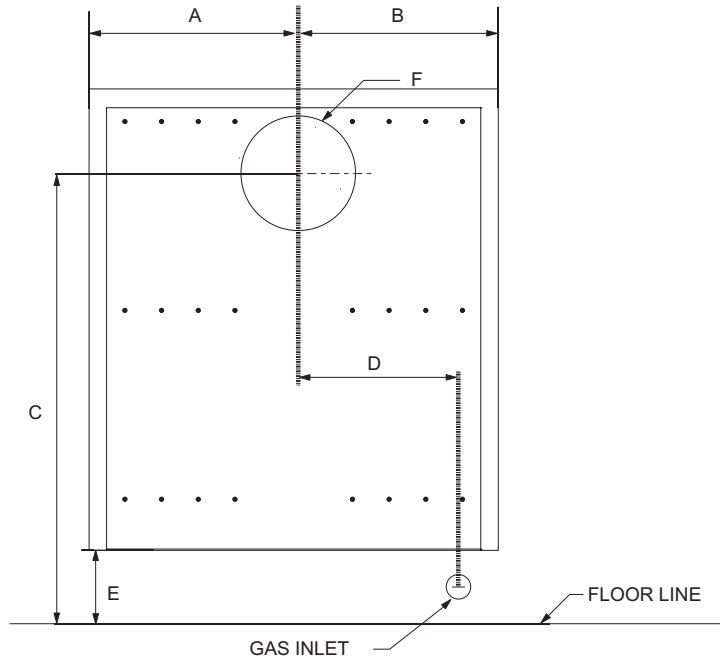

MEASUREMENTS		
Index	HWDV100(X,BX)	HWDV150(X,BX)
A	7-3/8in (187.3mm)	11-3/8in (288.9mm)
B	10-7/8in (276.2mm)	10-7/8in (276.2mm)
C	21in (533.4mm) min	24-5/8in (625.5mm) min
D	9-1/8in (231.8mm)	9-1/8in (231.8mm)
E*	4in (101.6mm) min	4in (101.6mm) min
F	6-1/4in (158.8mm) min 7in (177.8mm) max	6-1/4in (158.8mm) min 7in (177.8mm) max

*For residential garage installations, add 4-1/2in (114.3mm).

2

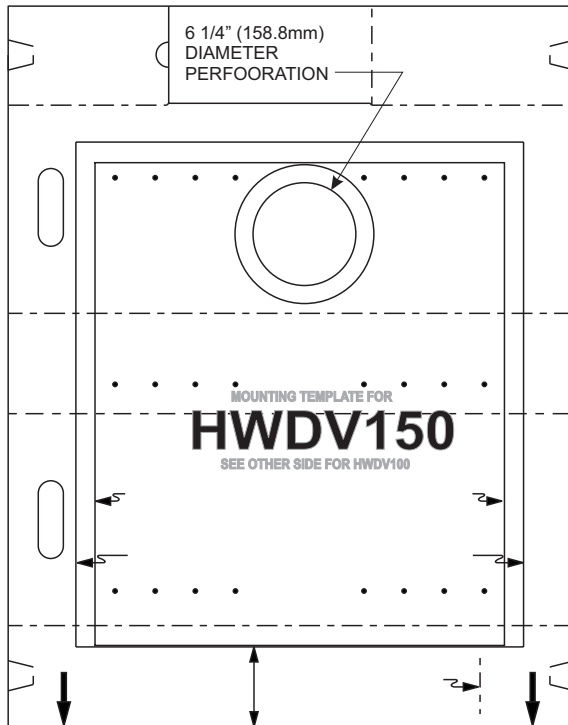

Locate the wall mounting plate template included in your shipping carton and remove the 6-1/4in (158.8mm) diameter perforated section. Use painters tape to secure the wall mounting plate template onto the interior wall where the heater will be located. (Template for HWDV100 will be on the opposite side of the shown template.)

3

Trace the template wall opening and (if applicable) the gas inlet hole onto the wall. Mark the six wall mounting plate screw holes onto the wall. The size of the gas inlet hole will depend upon the size of gas pipe coming into the unit. (See this page, box 1 and page 21, box 4).

INTERIOR INSTALLATION (CONT'D)

4

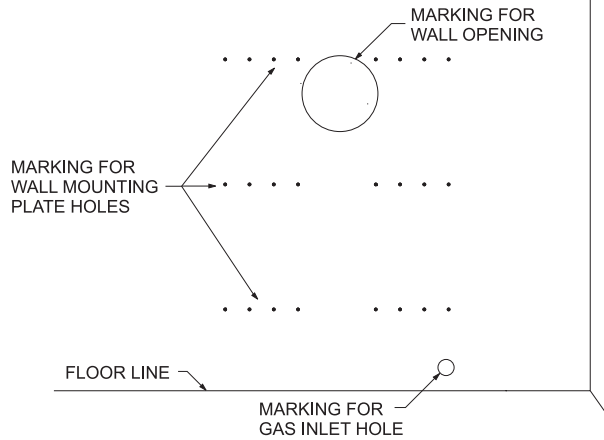

Remove the template from the wall after the wall openings are marked. The wall opening location markings should be present on the wall. Ensure the wall studs do not interfere with the wall opening.

5

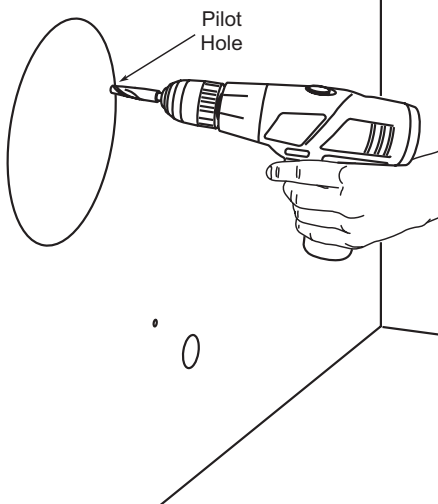

Drill a pilot hole inside of the traced circle so that a saw can be used to cut the wall openings out.

6

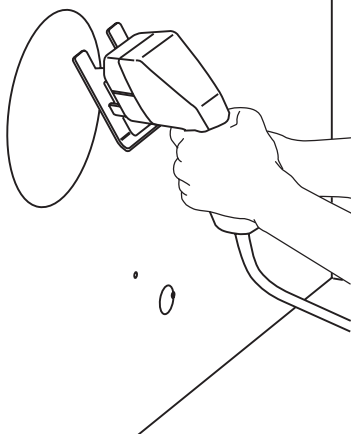

Use a saw to cut the wall openings out of the wall and discard the inner circle debris. Add a horizontal cross brace above the wall opening between the wall studs to prevent insulation from contacting the vent tube. The wall is now prepared for the installation of the unit.

INTERIOR INSTALLATION (CONT'D)

7 Before installing unit, remove wall mounting plate from back of unit.

8

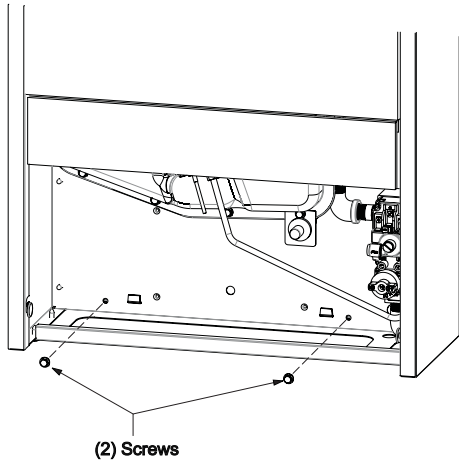

Push on bottom of casing door to open it. Pivot and remove casing door. Remove two screws from the back inside of the unit and detach the wall mounting plate from outside back of the unit.

9

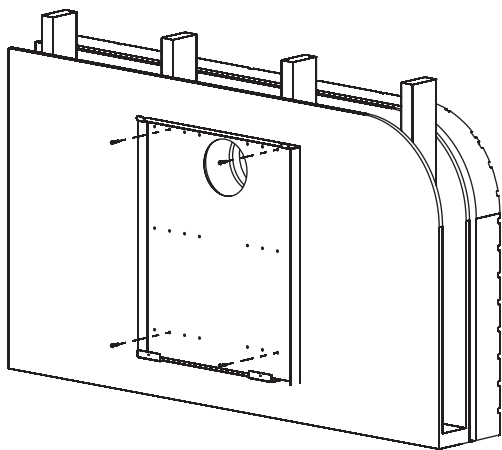

Locate the studs in the wall and use at least four wood screws to attach the wall mounting plate to the wall. If installing onto drywall (not into a stud), anchors must be used.

10

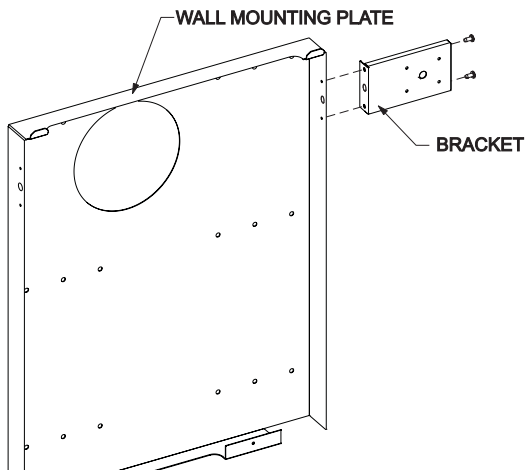

The optional bracket can be installed directly to the left or right side of the wall mounting plate.

For optional on/off device, use two #8 x 3/8in screws (provided) to attach the bracket to the wall mounting plate as shown.

INTERIOR INSTALLATION (CONT'D)

11

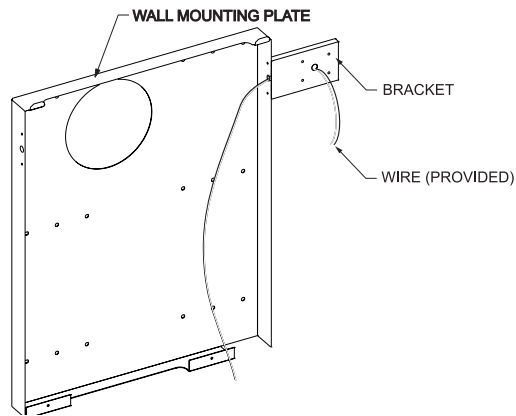

Thread one end of the optional on/off device wire through bracket and the wall mounting plate as shown.

12

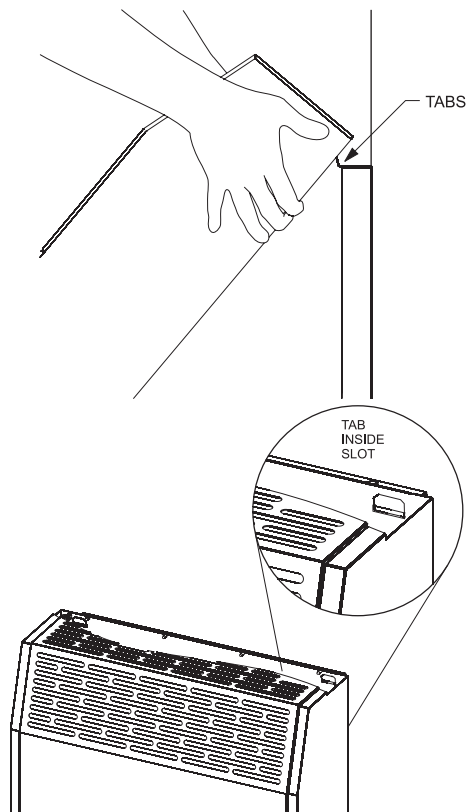

Line up the two tabs on the top of the wall mounting plate with the slots in the back of the unit. Slide the back of the unit onto the tabs of the wall mounting plate.

13

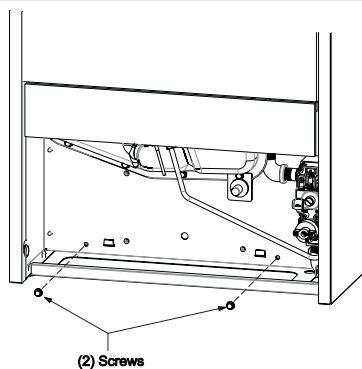

Secure the back of the unit into place using two screws removed in step 8.

INTERIOR INSTALLATION (CONT'D)

14

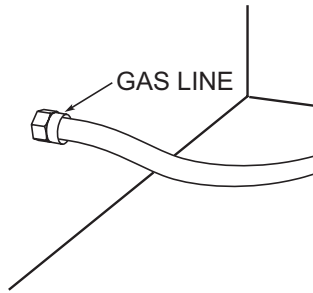

After the back of the unit is attached to the wall, bring in the gas line as shown on page 15, or follow the installation template indications. Following your city, local and state codes, attach the gas line to the unit.

⚠ CAUTION

Grasp wrench on regulator when installing gas inlet.

NOTE: The gas line can come through the wall or floor of the house.

15

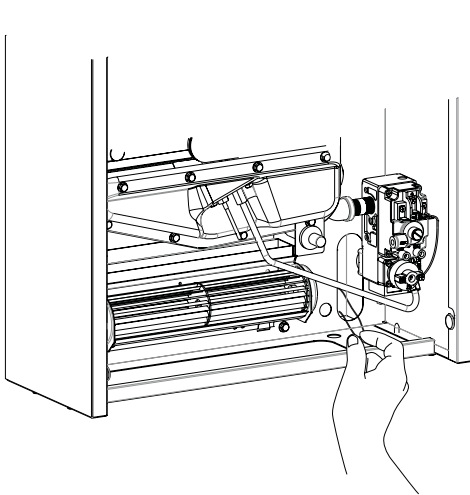

Thread the optional on/off device wire through the oblong hole in the rear of the heater casing.

INTERIOR INSTALLATION (CONT'D)

16

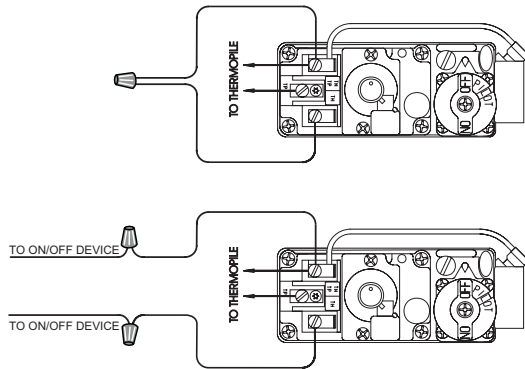

Unscrew the wire nut securing the jumper wires on the valve (retain the wire nut). Connect the wires from the optional on/off device and secure with two wire nuts; one each connection.

17

Place one nylon washer on each peg of the casing door. Replace casing door.

Installing the ON/OFF Device

To install an ON/OFF device (such as a wall switch, remote, toggle switch, or thermostat), remove the wire nut from the two wires from the valve. Run additional wire from the valve wires to the ON/OFF device. Install the ON/OFF device in the same room as the furnace following the installation instructions supplied with it. In the absence of instructions, install the ON/OFF device 4 to 5 feet above the floor on an interior wall not affected by another heating source (i.e. stove or water heater) or the temperature of an adjoining room.

CUTTING THE VENT TUBES

NOTE: Flue outlet tube and air inlet tube should be measured and cut to the proper length from the back of the unit to the outside wall of the house. See page 27, boxes 3 and 4.

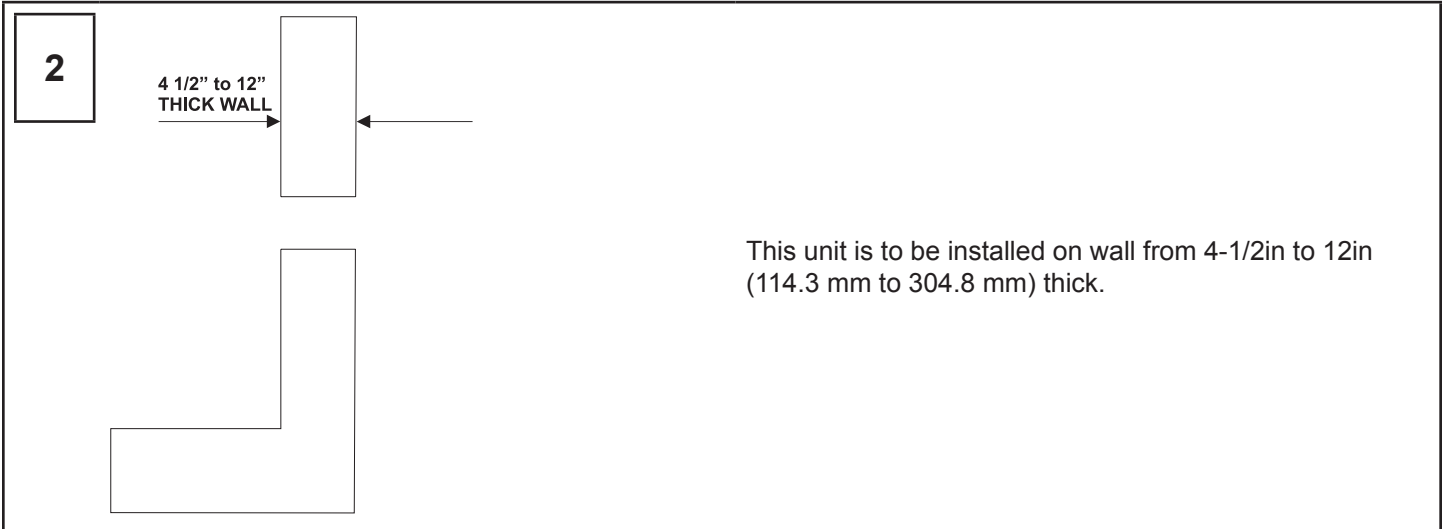
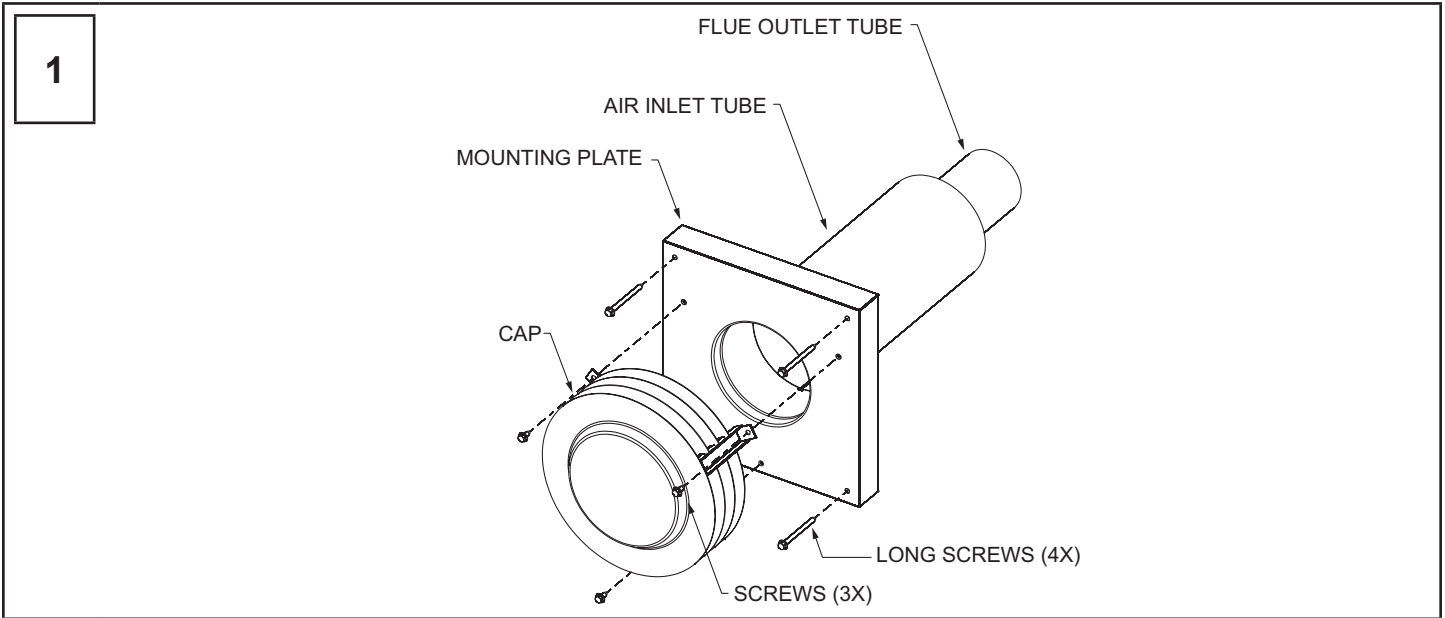

CUTTING THE VENT TUBES (CONT'D)

With the furnace installed on wall the 5in (127mm) diameter air inlet tube and 3in (76.2mm) diameter flue outlet tube are to be marked and cut using the following procedure. After cutting the tubes, each tube should be individually checked for proper length before installing by fitting in place.

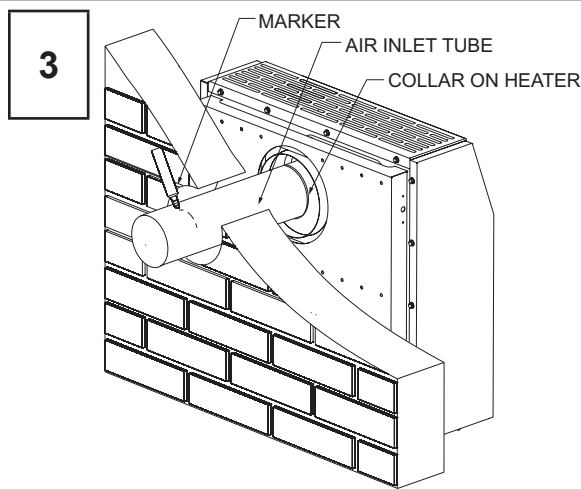

Attach 5in (127mm) diameter air inlet tube onto the collar of the heater. Be sure 5in (127mm) diameter air inlet tube is placed as far as possible onto the collar of the heater. Mark the 5in (127mm) diameter air inlet tube 1-7/16in (36.5mm) beyond the mounting surface for the outside wall plate. Remove 5in (127mm) diameter air inlet tube from collar of the heater.

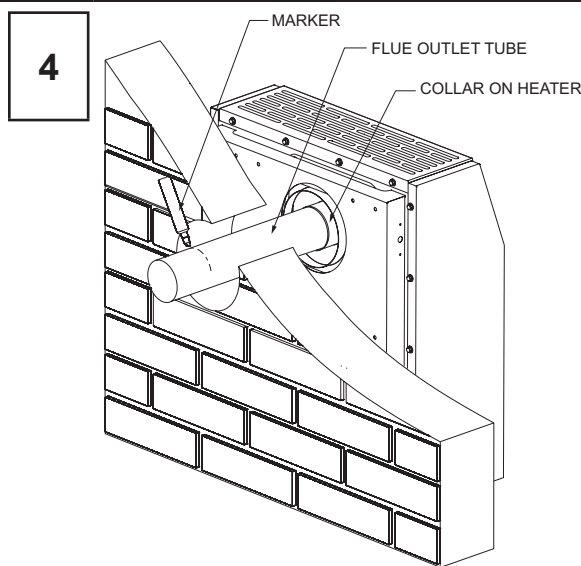

Attach 3in (76.2mm) diameter flue outlet tube onto flue outlet collar on combustion chamber. Be sure 3in (76.2mm) diameter flue outlet tube is placed as far as possible onto the collar of flue outlet. Mark the 3in (76.2mm) diameter flue outlet tube 2-7/8in (73.0mm) beyond the mounting surface for the outside wall plate. Remove 3in (76.2mm) diameter flue outlet tube from collar of flue outlet on combustion chamber.

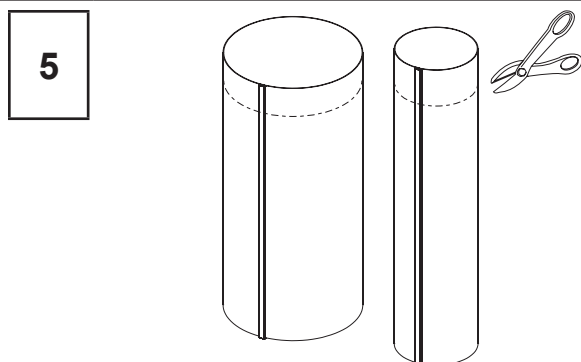

Mark or wrap tape completely around the tubes at the marked points to help in making a true cut. Do not crimp or enlarge tubes. Remove tape after cutting the tubes.

EXTERIOR INSTALLATION OF THE VENTING

NOTE: Flue outlet tube and air inlet tube should be measured and cut to the proper length from the back of the unit to the outside wall of the house. There should be little to no venting showing on the outside of the house.

1

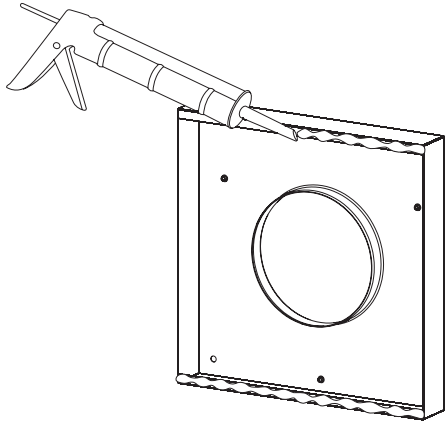

Place caulk (not provided) beneath the edge of the outside wall mounting plate. Use additional caulk to correct uneven wall surface, such as clapboard.

2

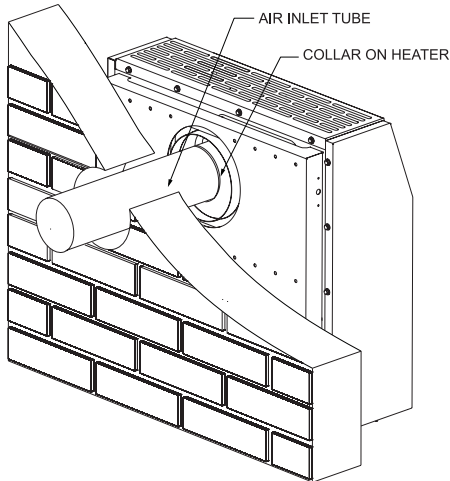

Attach 5in (127mm) diameter air inlet tube onto the collar of the heater. Attach caulked, outside wall mounting plate into the 5in (127mm) diameter air inlet tube.

3

(4) #10 x 2 1/2" SCREWS

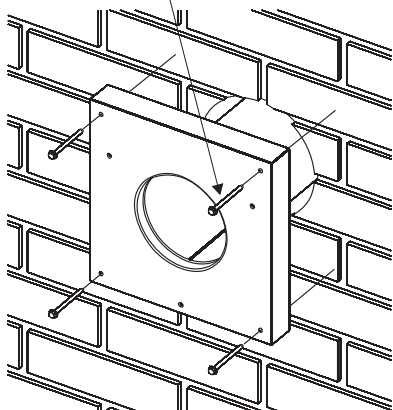

Position the outside wall mounting plate so that 5in (127mm) diameter air inlet tube has a slight downward slope to the outside. The downward slope is necessary to prevent the entry of rainwater. Attach outside wall mounting plate to exterior wall with #10 x 2 1/2in screws provided.

EXTERIOR INSTALLATION OF THE VENTING (CONT'D)

4

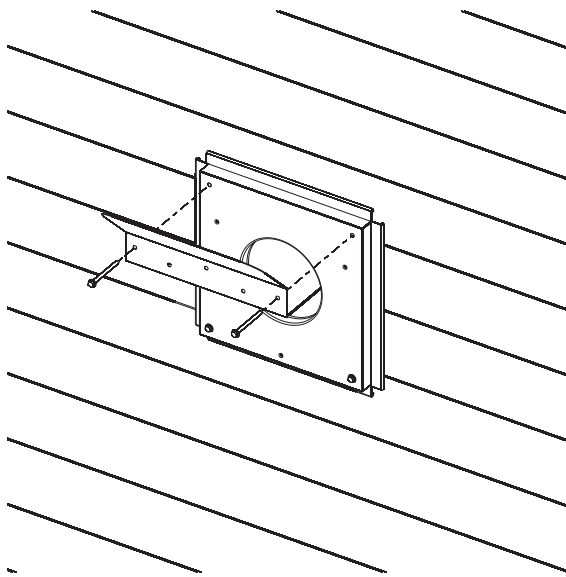

If installing onto vinyl, aluminum, or any type of siding that may warp or discolor, attach vent shield using two of the screws that attach the outside wall mounting plate.

5

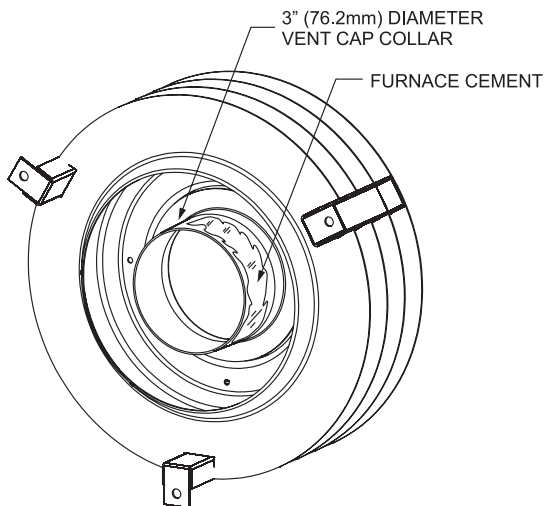

Apply furnace cement (not provided) to 3in (76.2mm) diameter collar on vent cap.

6

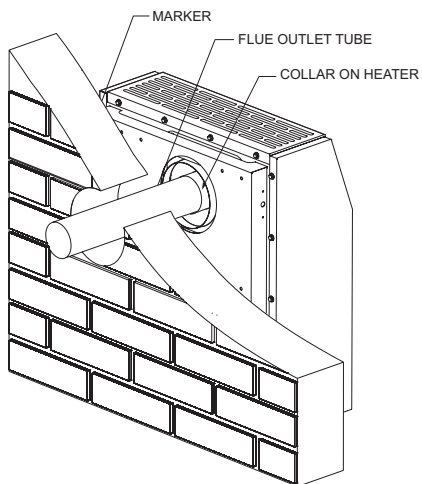

Attach 3in (76.2mm) diameter flue outlet tube onto flue outlet collar on combustion chamber. Flue outlet tube must be tightly sealed against the heater and vent cap for safe and proper operation.

EXTERIOR INSTALLATION OF THE VENTING (CONT'D)

7

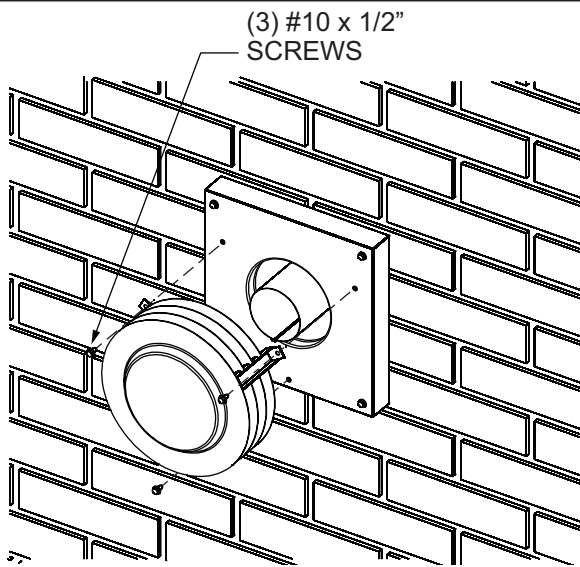

Attach vent cap into the 3in (76.2 mm) diameter flue outlet tube. Attach vent cap to outside wall mounting plate with three #10 x 1/2in screws provided.

8

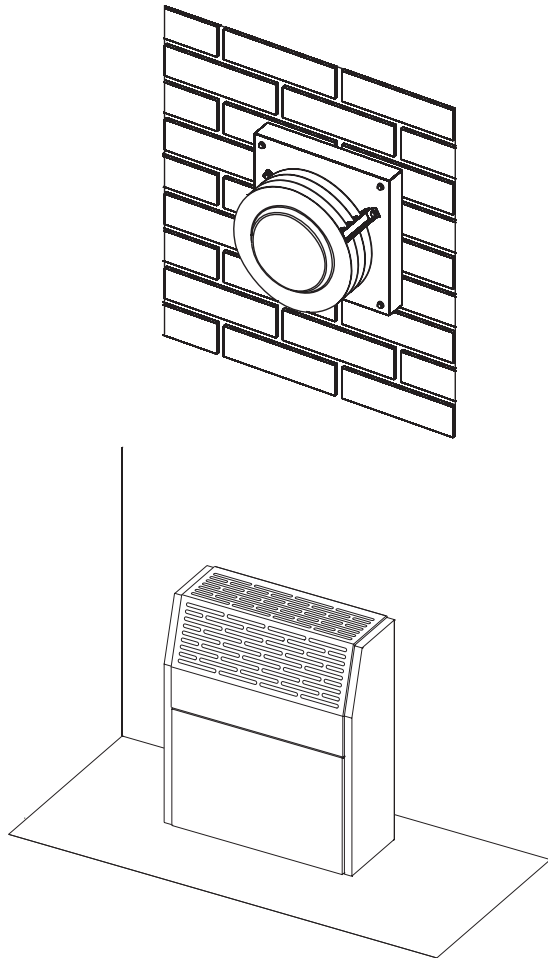

Installation of this Housewarmer product is complete.

REASSEMBLY AND RESEALING VENTING SYSTEM

When vent-air intake system is removed for servicing the furnace, the following steps will assure proper reassembly and resealing of the vent-air intake assembly.

1

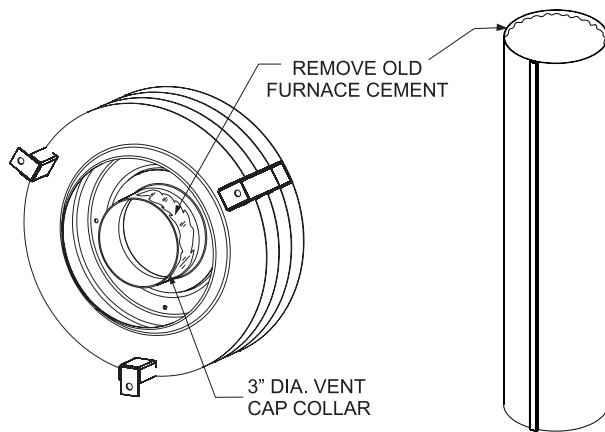

Remove old furnace cement from vent cap collar and flue outlet tube.

2

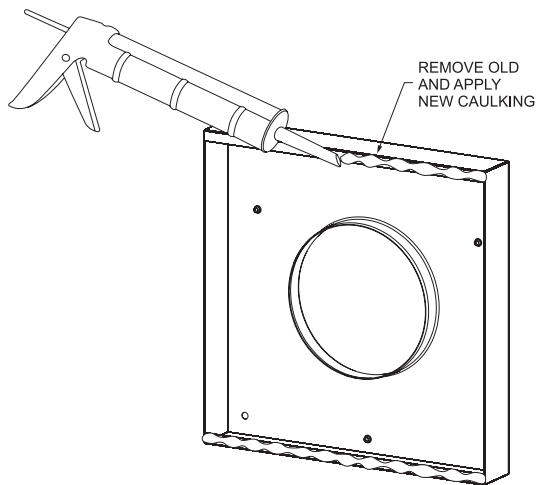

Remove old caulk from the outside wall mounting plate. Apply new caulk beneath the edge of the outside wall mounting plate. Use additional caulk to correct uneven wall surface, such as clapboard.

3

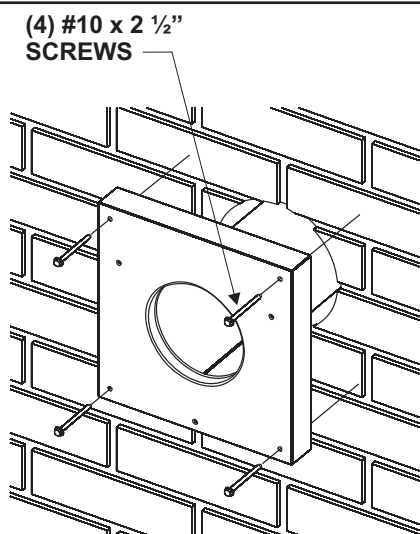

Attach 5in (127mm) diameter air inlet tube onto the collar of the heater. Attach caulked, outside wall mounting plate into the 5in (127mm) diameter air inlet tube. Position the outside wall mounting plate so that 5in (127mm) diameter air inlet tube has a slight downward slope to the outside. The downward slope is necessary to prevent the entry of rainwater. Attach outside wall mounting plate to exterior wall with four #10 x 2-1/2in screws previously removed.

REASSEMBLY AND RESEALING VENTING SYSTEM (CONT'D)

4

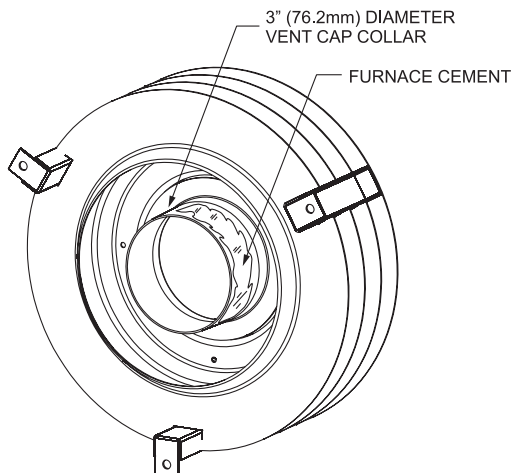

Apply furnace cement to 3in (76.2mm) diameter collar on vent cap.

5

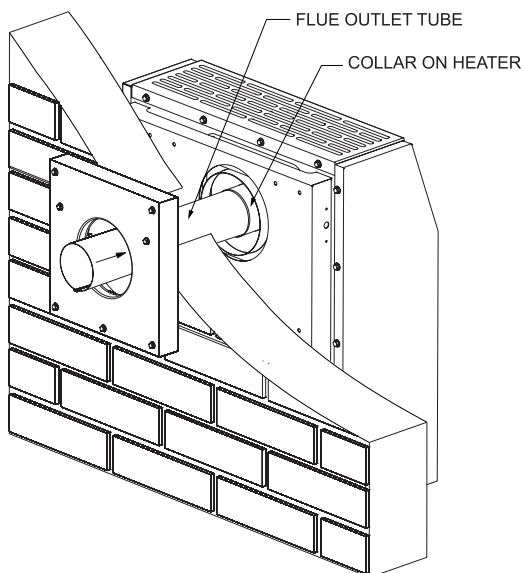

Attach 3in (76.2mm) diameter flue outlet tube onto flue outlet collar on heater.

REASSEMBLY AND RESEALING VENTING SYSTEM (CONT'D)

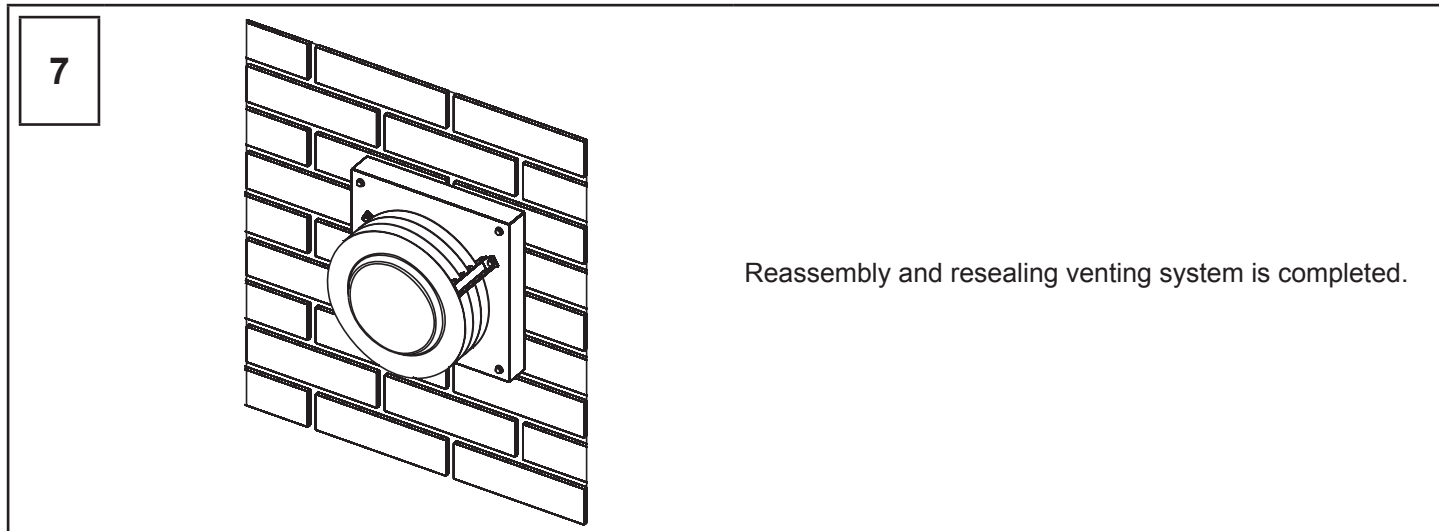
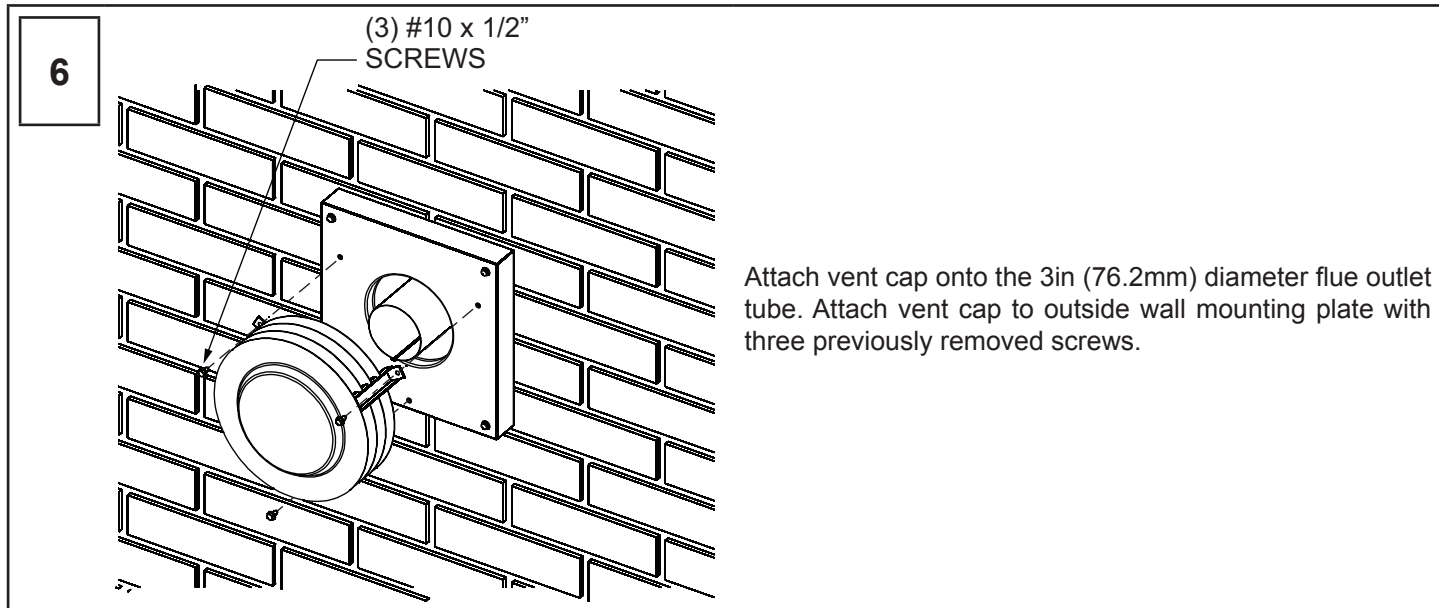

INSTALLATION OF OPTIONAL BLOWER KIT HW125SCB

1

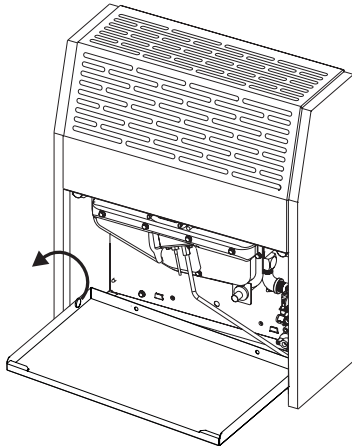

Remove front panel of heater by opening, then lifting one side out then the other. Be careful not to lose the white nylon washers on the front panel.

2

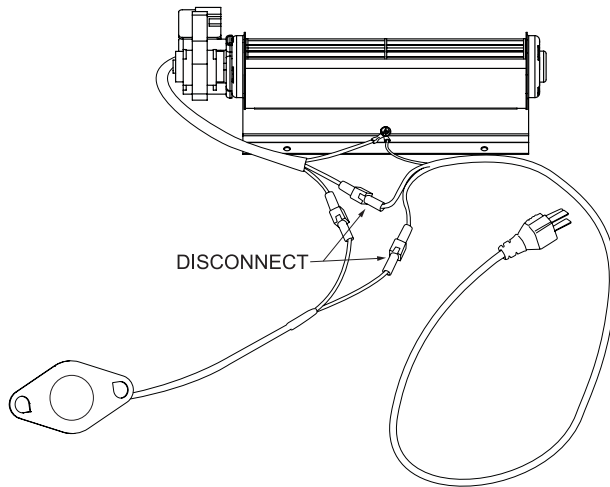

Disconnect the power cord from the blower assembly.

3

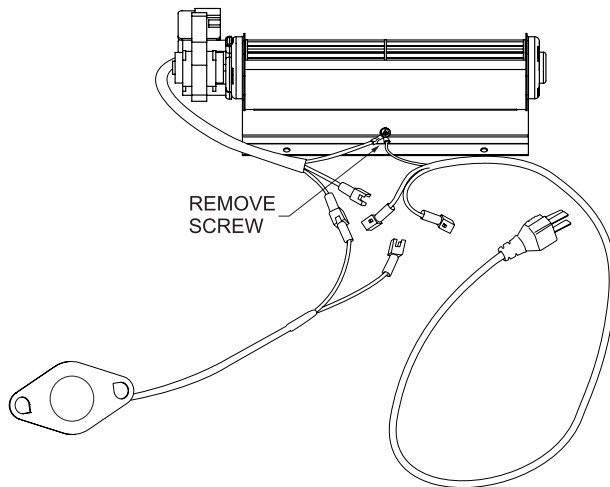

Remove ground screw from blower mounting bracket.

INSTALLATION OF OPTIONAL BLOWER KIT HW125SCB (CONT'D)

4

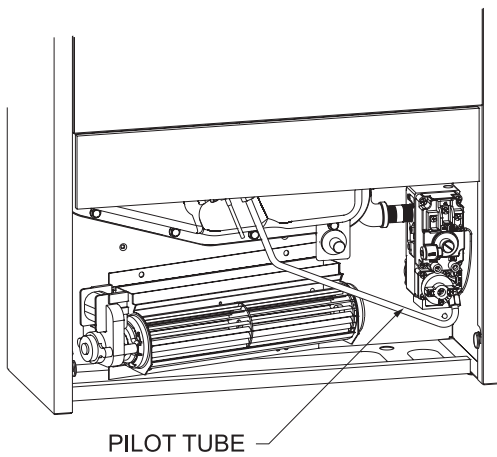

Insert the blower behind the pilot tube and into the heater casing.

NOTE: Blower wires removed in image for clarity.

5

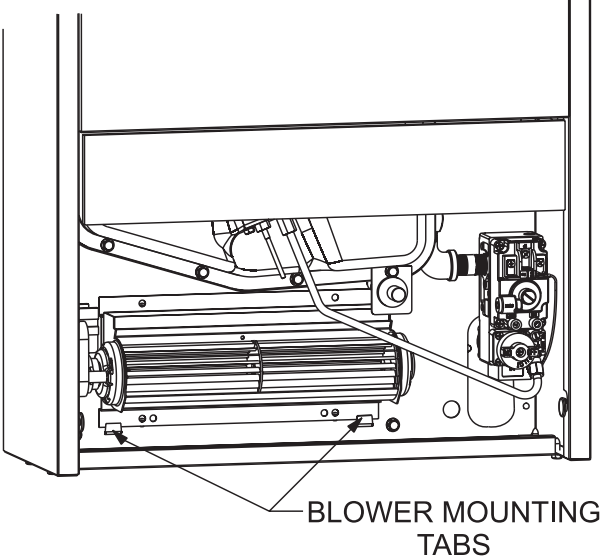

Slide the blower into the blower mounting tabs as shown .

6

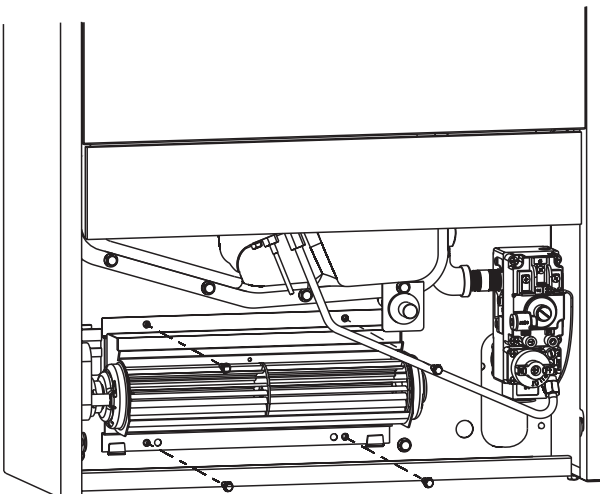

Use four # 8 x 3/8in screws to secure the blower to the heater casing.

INSTALLATION OF OPTIONAL BLOWER KIT HW125SCB (CONT'D)

7

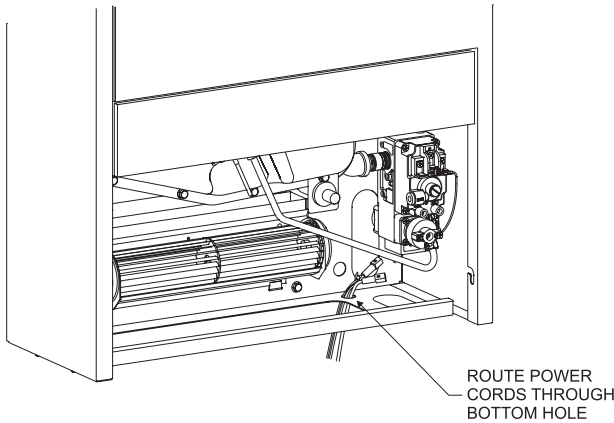

Route the power cords through the smaller hole in the bottom of the heater casing as shown.

8

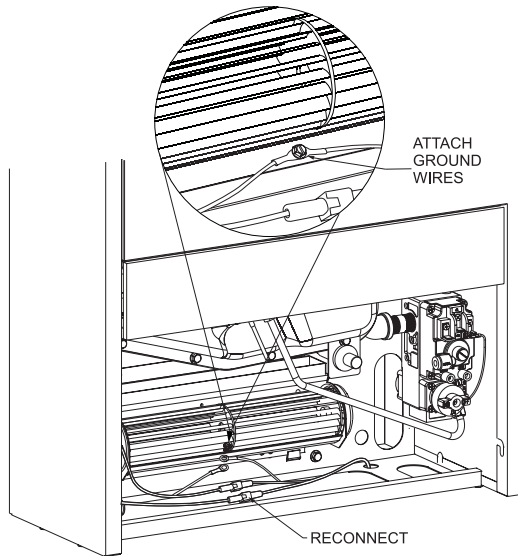

Reconnect power cord to blower assembly. Attach ground wires from the blower and power cord to the blower mounting bracket.

9

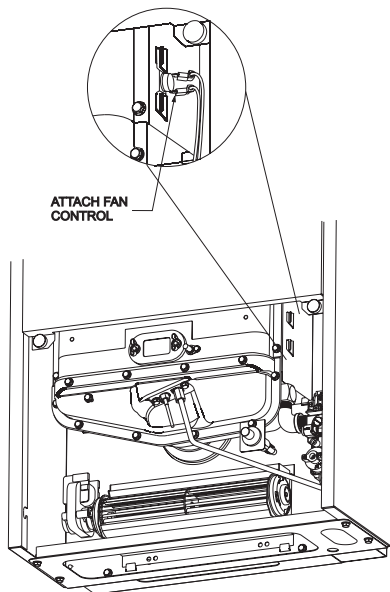

Slide fan control into the tabs on the right side of the chamber support.

INSTALLATION OF OPTIONAL BLOWER KIT HW125SCB (CONT'D)

10

CAREFULLY BEND

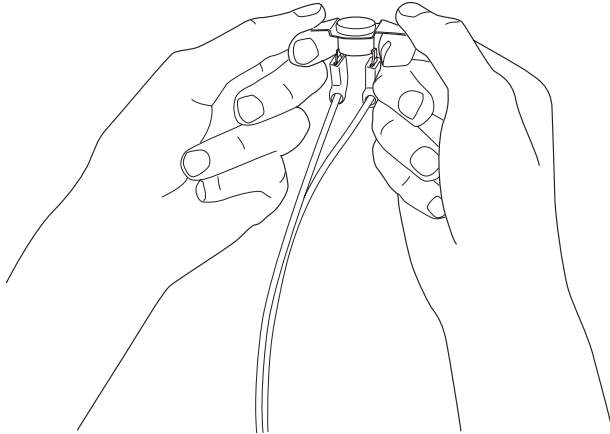

If the fan control does not stay in place after installation, remove the fan control and gently bend the flanges in either direction as needed and slide it back into place. A slight bend is all that will be necessary. DO NOT use excessive force or tools to bend the flanges or breakage may occur.

11

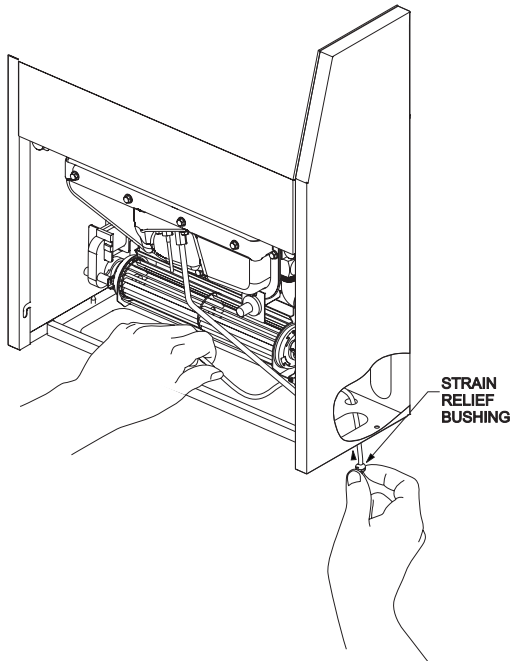

STRAIN
RELIEF
BUSHING

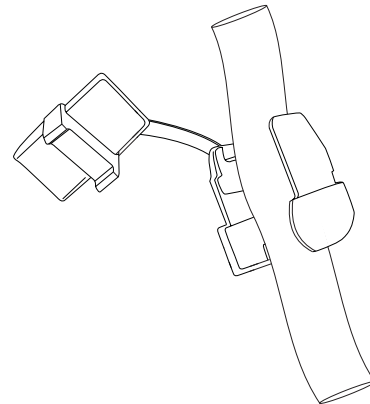

Pull power cord from bottom to remove any excess wire from inside of the heater and attach strain relief bushing to the cord on the underside of the heater. Insert strain relief bushing into hole in the bottom of the heater.

12

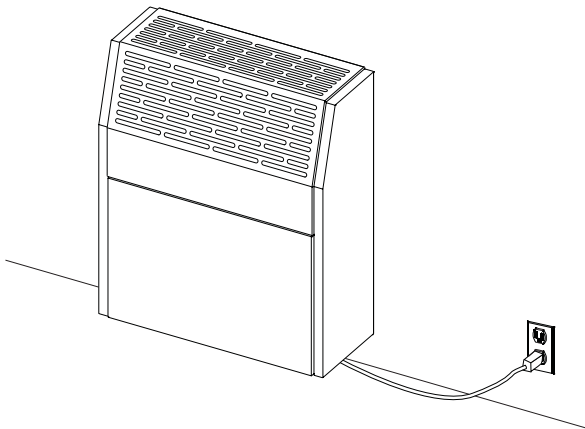

Plug power cord into wall receptacle and reattach front panel of heater to complete installation. Verify that the plastic washers are still in place on the front panel when replacing it.

For replacement parts see Parts List on page 45 and Parts View on page 44.

BEFORE OPERATING APPLIANCE

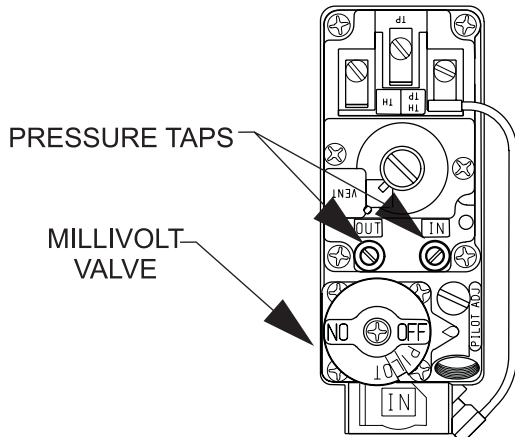

⚠ WARNING

Improper installation, adjustments, alterations, service or maintenance can cause property damage, personal injury or loss of life. Installation and service must be conducted by a Qualified Service Person.

Under no circumstances should this heater be modified.

In case of gas leaks, turn gas valve off and call your Qualified Service Person.

ATTENTION INSTALLER:

The appliance must be isolated from the gas supply piping system by closing its equipment shut-off valve during any pressure testing of the gas supply piping system at test pressures equal to or less than 1/2 psi (3.5 kPa).

The appliance and its appliance main gas valve must be disconnected from the gas supply piping system during any pressure testing of that system at test pressures in excess of 1/2 psi (3.5 kPa).

OPERATING INSTRUCTIONS

FOR YOUR SAFETY READ BEFORE LIGHTING

WARNING

Improper installation, adjustment, alteration, service or maintenance can cause property damage, personal injury, or loss of life. Installation and service must be performed by a qualified installer, service agency or the gas supplier. Keep burner and control compartment clean.

- A) This appliance has a pilot which must be lighted by hand. When lighting the pilot, follow these instructions exactly.
- B) BEFORE LIGHTING, smell all around the appliance area for gas. Be sure to smell next to the floor because some gas is heavier than air and will settle on the floor.

WHAT TO DO IF YOU SMELL GAS:

- Do not try to light any appliance.
 - Do not touch any electrical switch; do not use any phone in your building.
 - Immediately call your gas supplier from a neighbor's phone. Follow the gas supplier's instructions.
 - If you cannot reach your gas supplier, call the fire department.
- C) Use only your hands to push in or turn the gas control knob. Never use tools. If the knob will not push in or turn by hand, do not try to repair it; call a qualified service technician. Force or attempted repair may result in a fire or explosion.

- D) Do not use this appliance if it has been under water. Immediately call a qualified service technician to inspect the heater and to replace any part of the control system and any gas control which has been under water.

NOTE: It is normal for the new heater to give off some odor the first time it is lit. This is due to final paint curing and to any undetected oil remaining from the manufacturing process. It is recommended that you operate your new wall heater for at least two hours the first time you use it.

ONCE THE UNIT IS IN OPERATION, CHECK ALL GAS CONNECTIONS WITH A SOAPY WATER SOLUTION. CHECK THE TEST POINT PRESSURE; IT MUST BE 4in W.C. FOR NATURAL GAS AND 10.0in W.C. FOR PROPANE GAS.

LIGHTING INSTRUCTIONS

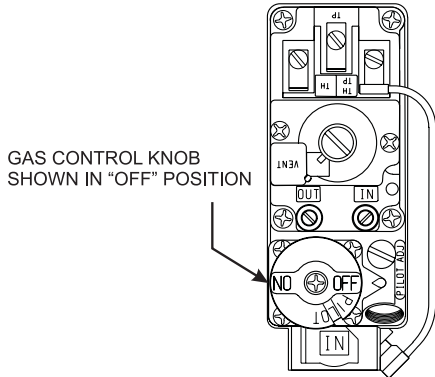

1. STOP! Read the safety information on page 39.
2. Turn off all electric power to the appliance (if applicable).
3. Open control access panel (front panel).
4. Push in gas control knob slightly and turn clockwise  to OFF.



NOTE: Knob cannot be turned from "PILOT" to "OFF" unless knob is pushed in slightly. Do not force.

5. Wait ten minutes to clear out any gas. Then smell for gas, including near the floor. If you smell gas, STOP! Follow "B" in the safety information on page 39. If you don't smell gas, go to the next step.



6. Remove the pilot access cover located on the combustion chamber.
7. Find pilot - follow metal tube from gas control. The pilot is behind the pilot access cover.
8. Turn knob on gas control counterclockwise  to "PILOT."
9. Push in control knob all the way and hold in. Immediately light the pilot with the Piezo Pilot Ignitor or a match. Continue to hold the control knob in for about one minute after the pilot is lit. Release knob, and it will pop back up. Pilot should remain lit. If it goes out, repeat steps 5 through 10.
 - If knob does not pop up when released, stop and immediately call your service technician or gas supplier.
 - If the pilot will not stay lit after several tries, turn the gas control knob to "OFF" and call your service technician or gas supplier.
10. Replace pilot access cover.
11. CAUTION: Pilot access cover must be kept tightly closed during operation.
12. Turn gas control knob counterclockwise  to "ON."
13. Replace control access panel (front panel).
14. Turn on all electric power to the appliance (if applicable).

TO TURN OFF GAS TO APPLIANCE

1. Turn off all electric power to appliance if service is to be performed (if applicable).
2. Remove control access panel (front panel).
3. Push in gas control knob slightly and turn clockwise  to "OFF." Do not force.
4. Close control access panel (front panel).

PILOT FLAME CHARACTERISTICS

1

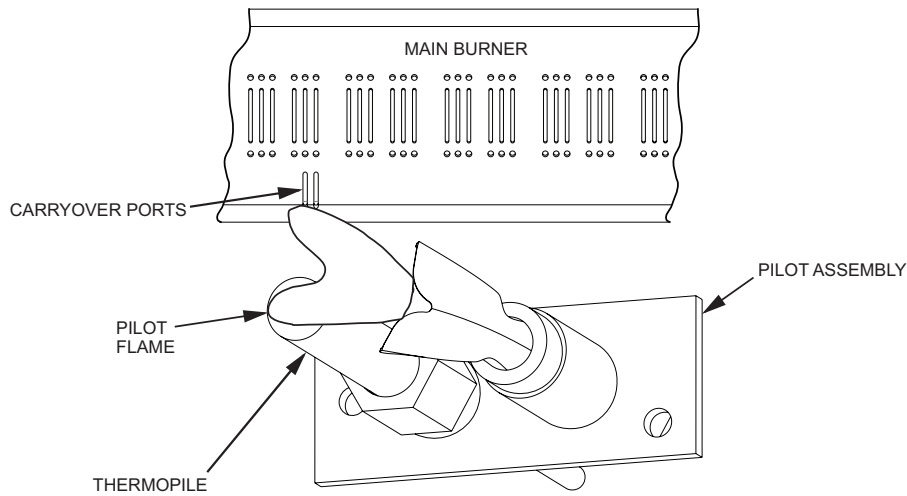

The pilot flame is blue and goes toward the main burner and thermocouple horizontally. A slight yellow tip on the flame is normal. The pilot flame must surround and extend approximately 1/4in (6.4mm) beyond the thermocouple, and must extend beyond the first row toward the second row of main burner ports.

MAIN BURNER FLAME CHARACTERISTICS

1

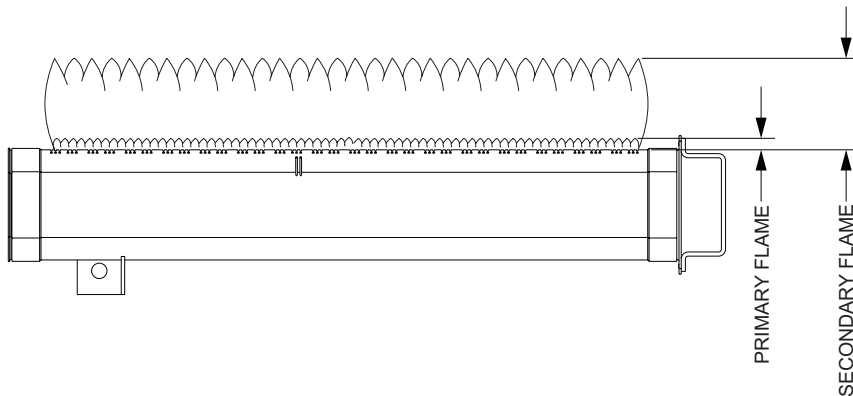

On the main burner, the burning gas forms a primary flame and a secondary flame. The primary flame is blue and about 3/16in (4.8mm) high. The secondary flame is very pale blue, 3in (76.2mm) to 5in (127mm) high. Dust in the combustion air will produce an orange flame. Do not mistake it for an improper yellow flame.

MAINTENANCE INSTRUCTIONS

Installation, repair and maintenance should be done by a **QUALIFIED SERVICE PERSON.**

Steps in Removing Main Burner, Orifice and Valve

1. Disconnect the thermopile and pilot supply line at the pilot burner.
2. Remove the burner compartment cover 5/16in (7.9mm) socket suggested.
3. Remove screw holding left side of burner and lift out.
4. Main burner orifice is now accessible. Use 1/2in (12.7mm) box end wrench to remove and apply non-hardening pipe dope sparingly to orifice threads when replaced.
5. To remove the entire gas valve the nut holding the orifice fitting to the chamber must be removed and the gas supply to the valve disconnected. After this, the valve and orifice elbow can be removed as a unit.

Cleaning The Pilot Burner

Cleaning of the pilot may be an annual necessity due to spiders. After removing the supply tubing and orifice, use a pipe cleaner or wire to clean the entire internal part of the pilot.

Cleaning the Combustion Chamber and Main Burner

When the main burner and vent cap are removed, all internal areas of the combustion chamber are accessible for cleaning with a vacuum hose. The main burner may be cleaned by forcing water into the ports and the throat of the burner. The burner should be blown dry or heated to dry all water out before reinstalling.

IMPORTANT: The appliance's venting system should be inspected at least once a year and immediately cleaned if necessary.

TROUBLESHOOTING

- 1. Lit match goes out as it enters lighter port.**
 - a. Certain wind conditions will blow out match. Ignite match, and as it flares, thrust match through opening.
 - b. Open nearby door or window and relight pilot.
- 2. Pilot flames but goes out when knob is released.**
 - a. See Lighting Instructions. Relight Pilot.
 - b. Relight the pilot and hold knob down longer and harder. Close lighter hole cover just after igniting. Check for a good pilot flame.
 - c. Defective thermopile or defective magnet in safety section of valve. Replace.
- 3. Yellow pilot flame.**
 - a. Obstruction at pilot orifice.
 - b. Clean and properly size orifice.
- 4. Pilot and main burner go out during normal operation.**
 - a. Check millivolts.
 - b. Check for proper size of pilot flame.
 - c. Check for defective or weak thermopile.
 - d. Check input, reduce as needed.
 - e. Cover on pilot lighter hole must be air tight.
 - f. Check for tight fit of air and flue tubes at both ends of vent assembly. No obstruction around vent that would prevent the wind from hitting all of the vent equally.
- 5. Yellow main burner flame soot on the vent cap.**
 - a. Remove main burner to check for obstructions in throat, ports and orifices.
 - b. Install new main burner orifice and pilot orifice. Refer to Parts List.

PARTS LIST

PLEASE NOTE: When ordering parts, it is very important that part number and description of part coincide.

INDEX NO.	PART NUMBER		DESCRIPTION
	HWDV100	HWDV150	
1	33441	33442	WALL MOUNTING PLATE
2	41089	33959	CASING ASSEMBLY (INCLUDES CASING DOOR)
3	40988	33438	CASING ASSEMBLY (INCLUDES MAGNETS)
4	33960	33961	CASING DOOR
5	24577	24578	AIR DROP
6	40980	40981	CASING BACK
7	40960	40961	COMBUSTION CHAMBER
8	R12791	R12791	GAS VALVE, NATURAL GAS
8	R12792	R12792	GAS VALVE, PROPANE GAS
9	P104	P104	ORIFICE FITTING
10	P8654	-	ORIFICE #54 - NATURAL GAS
10	P8665	-	ORIFICE #65 - PROPANE GAS
10	-	P8650	ORIFICE #50 - NATURAL GAS
10	-	P8658	ORIFICE #58 - PROPANE GAS
11	41088	41088	PILOT TUBING (INCLUDES FERRULES)
12	TH289	TH289	IGNITOR BRACKET
13	R1055	R1055	ELECTRODE AND WIRE
14	R2708	R2708	PIEZO IGNITOR
15	40956	40957	BURNER
16	M155	M155	GASKET, OBSERVATION HOLE
17	DV781	DV781	OBSERVATION HOLE COVER
18	24681	24681	BLOWER WITH MOUNTING BRACKET
19	TH133	TH134	CHAMBER DOOR WITH GASKET
20	M151	M151	GASKET, PILOT
21	TH335	TH335	PILOT SHIELD
22	R12795	R12795	PILOT, NATURAL GAS
22	R12796	R12796	PILOT, PROPANE GAS
23	R1054	R1054	THERMOPILE
24	24624	24624	VENT KIT
25	TH109	TH109	FLUE OUTLET TUBE
26	TH107	TH107	AIR INLET TUBE
27	24625	24625	WALL MOUNTING PLATE, OUTSIDE
28	24626	24626	VENT SHIELD
29	TH334	TH334	VENT CAP

INDEX NO.	PART NUMBER		DESCRIPTION
	HWDV100	HWDV150	
30	24626	24626	VENT SHIELD
N/S	33455	33455	OPTIONAL ON/OFF DEVICE BRACKET
N/S	R1081	R1081	PILOT ORIFICE .014 - NATURAL GAS
N/S	R1089	R1089	PILOT ORIFICE .009 - PROPANE GAS
N/S	R9494	R9494	OPTIONAL ON/OFF DEVICE WIRE, 36 INCHES
N/S	41604	41604	HARDWARE PACKAGE
N/S	R7649	R7649	FAN CONTROL SWITCH, BLOWER
N/S	R9923	R9923	FAN CONTROL WIRE, BLOWER
N/S	R2099	R2099	POWER CORD, BLOWER
N/S	41086	33967	CONVERSION KIT, PROPANE TO NATURAL GAS
N/S	41087	33968	CONVERSION KIT, NATURAL TO PROPANE GAS
N/S	R206	R206	NUT, ORIFICE FITTING
N/S	R1122	R1122	WING NUT

N/S - NOT SHOWN

USE ONLY MANUFACTURER'S REPLACEMENT PARTS. USE OF ANY OTHER PARTS COULD CAUSE INJURY OR DEATH.

PARTS VIEW

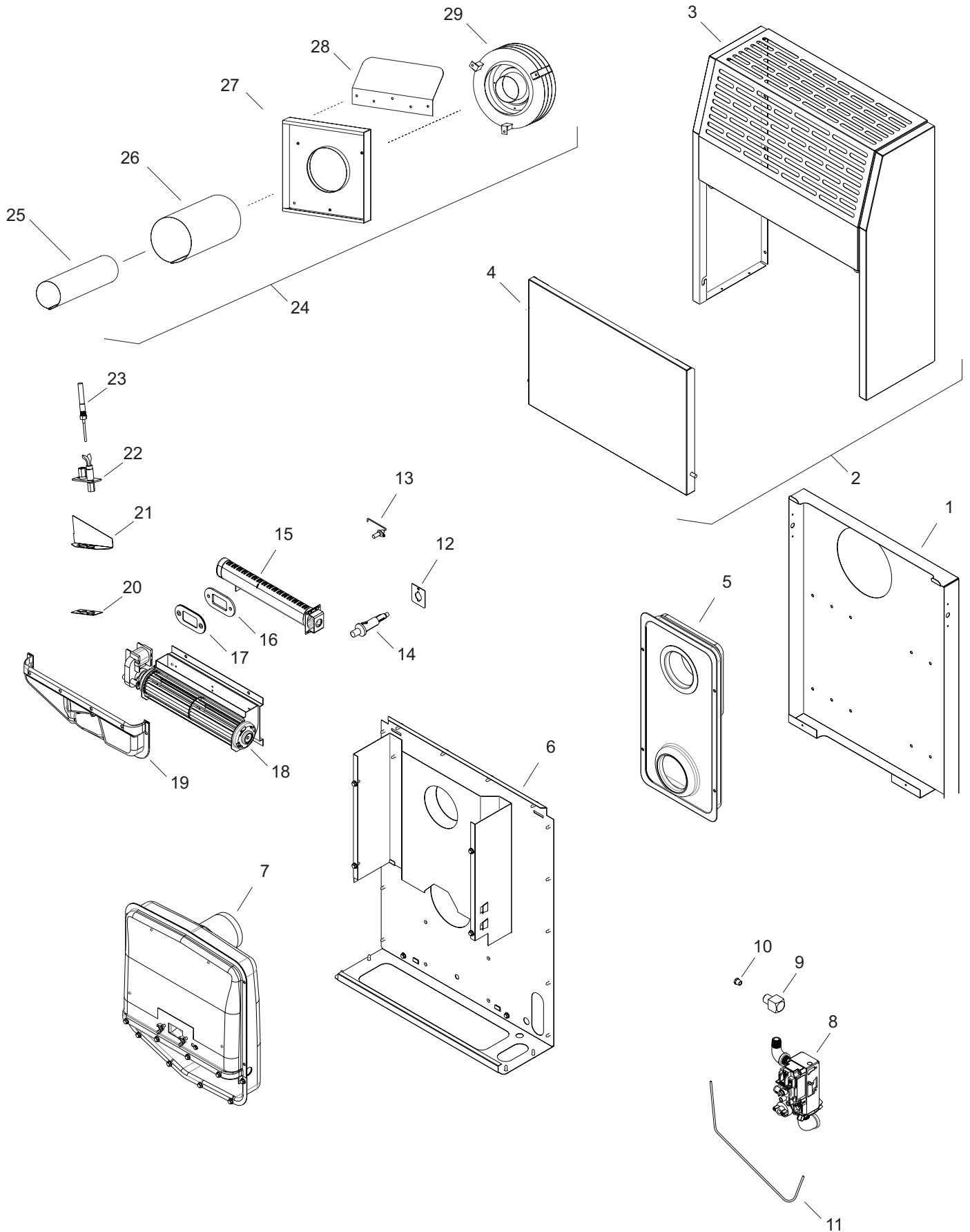

HOW TO ORDER REPAIR PARTS

To order parts, please visit our web site at www.housewarmerproducts.com or call 877-459-1583.

All parts listed in the **Parts List** have a **Part Number**. When ordering parts, first obtain the **Model Number** from the name plate on your equipment. Then determine the **Part Number (not the Index Number) and the Description** of each part from the following appropriate illustration and list. Be sure to give all this information.

Furnace Model Number _____ Part Description _____

Furnace Serial Number _____ Part Number _____

Type of Gas (Propane or Natural) _____

Do not order bolts, screws, washers or nuts. They are standard hardware items and can be purchased at any local hardware store.

Shipments contingent upon strikes, fires and all causes beyond our control.

Empire Comfort Systems, Inc. - Belleville, IL

WARRANTY INFORMATION

Empire Comfort Systems Inc. warrants this space heating product to be free from defects at the time of purchase and for the periods specified below. Space heating products must be installed by a qualified technician and must be maintained and operated safely, in accordance with the instructions in the owner's manual. This warranty applies to the original purchaser only and is not transferable. All warranty repairs must be accomplished by a qualified gas appliance technician.

PLACE OWNER'S IDENTIFICATION LABEL
HERE

COLOQUE AQUÍ LA ETIQUETA DE
IDENTIFICACIÓN DEL PROPIETARIO

Limited Ten-Year Parts Warranty – Combustion Chamber

If the combustion chamber (see parts list) fails because of defective workmanship or material with ten years from the date of purchase, Empire will repair or replace at Empire's option.

Limited One-Year Parts Warranty – Remote Controls, Accessories, and Parts

Should any remote control, accessory, or other part fail because of defective workmanship within one year from the date of purchase, Empire will repair or replace at Empire's option.

Duties of the Owner

The appliance must be installed by a qualified installer and operated in accordance with the instructions furnished with the appliance. A bill of sale, cancelled check, or payment record should be kept to verify purchase date and establish warranty period. Ready access to the appliance for service.

What Is Not Covered

Damages that might result from the use, misuse, or improper installation of this appliance.
Travel, diagnostic costs and freight charges on warranted parts to and from the factory.
Claims that do not involve defective workmanship or materials.
Unauthorized service or parts replacements.
Removal and reinstallation cost.
Inoperable due to improper or lack of maintenance.

How To Get Service

Service under this warranty must be obtained by contacting HouseWarmer 877-459-1583, Technical Support Group, Empire Comfort Systems, Inc. Provide the representative with the model number, serial number, type of gas, and purchase verification information.

Your Rights Under State Law

This warranty gives you specific legal rights, and you may also have other rights, which vary from state to state.

Garantía Limitada De 10 Años

Si la cámara de combustión (ver lista de repuestos) falla por razón de hechura o material en un término de diez años de la fecha de compra, Empire reparará o a opción de Empire, reemplazará la cámara defectuosa.

Obligación Del Dueño

El aparato de calefacción debe instalarse por un individuo calificado y debe de operarse de acuerdo con las instrucciones escritas que vienen con el aparato.

Acceso claro para darle servicio al aparato es responsabilidad del dueño.

Documentos de venta, cheques cancelados o pruebas de pago deben de mantenerse para verificar fecha de compra y establecer periodo de garantía.

Qué No Está Cubierto

Esta garantía no implica o assume responsabilidad alguna por daños consecuentes que puedan resultar por el mal uso o instalación inapropiada de este aparato de calefacción.

Esta garantía no cubre reclamos que no tengan que ver con una hechura defectuosa o material defectuoso.

Como Obtener Servicio

Servicio en esta garantía debe de obtenerse contacteando su comerciante de Empire. (Ver el directorio telefónico o llamar al código de area 877-459-1583, Customer Relations Department, Empire Comfort Systems, Inc.) Suministre al comerciante el número de serie, tipo de gas e información de verificación de compra.

Sus Derechos De Acuerdo Con La Ley

Esta garantía le dá a Ud. derechos legales específicos, y Ud. podría tener otros derechos, los cuales varían de estado.



HOUSEWARMER

HOUSEWARMER is a registered trademark of
Empire Comfort Systems Inc.
www.housewarmerproducts.com



Manufactured for:
Empire Comfort Systems Inc.
Belleville, IL