



KX 1000



LTE/CELL SIGNAL BOOSTER

User Manual

powered by weBoost®



BEFORE YOU START



Read through this manual before installing or operating the KING Extend.

If you have any questions, call KING Customer Service at (952) 345-8147.

CONTENTS

CONTENTS.....	2
IMPORTANT POINTS.....	3
COMPONENT LOCATIONS.....	4
OUTSIDE ANTENNA MOUNTING OPTIONS.....	5
INSTALLATION.....	6-7
MEASURING BOOSTER PERFORMANCE.....	8-9
SIGNAL BOOSTER STATUS LIGHT.....	10
TROUBLESHOOTING.....	11
SPECIFICATIONS.....	12-13
SAFETY GUIDELINES.....	14
WARRANTY.....	15

CONTENTS

Signal
Booster

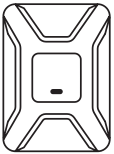

Outside Antenna



Inside Antenna

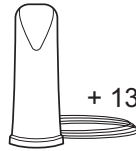

+ 13' Cable

20' Cable



Mounting
Bracket

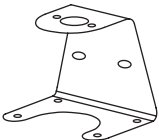

Ladder or Pole
Mounting Hardware

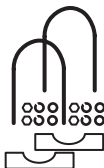

AC/DC
Power Supply

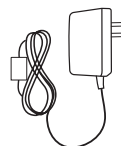

Instructions



IMPORTANT POINTS

You will need a drill and drill bit, roof-compatible sealant and appropriate fasteners to install all components and wiring.



The installer is responsible for determining the most appropriate fasteners to secure the antenna bracket to the roof. Depending on the roof material, fasteners such as lag screws, well nuts, sheet metal screws, toggle bolts and T anchors may be used, and should always be used in combination with a roof-compatible sealant.



The installer is responsible for properly securing the coax cable to the roof (for example, cable ties and cable tie mounting pads).



The installer is responsible for weatherproofing all holes and fastener heads with roof-compatible sealant.



Do not put sharp bends in coax cables. This can reduce signal strength from the antenna.

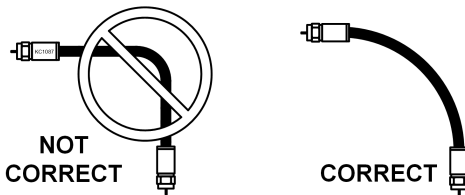

Antennas connected to a booster create spheres of signal. When these spheres overlap, a condition called oscillation occurs. Oscillation can be thought of as noise, which causes the booster to shut down to prevent damage. The best way to keep these spheres of signal from overlapping is to maximize separation between the booster and the antenna.

IMPORTANT! The aluminum casing of your signal booster will adjust to the temperature of its environment, but is designed to protect the signal booster technology. For example, in the summer, the signal booster case may be as hot as 150 degrees inside your vehicle. These high temperatures will not damage the signal booster, nor do they pose a fire risk to the vehicle. Again, be sure to place your signal booster in a location with adequate ventilation and away from direct sunlight or moisture.

The signal booster may remain on in vehicles whose 12V DC power sources do not automatically shut down when the vehicle is turned off. This could result in discharging the vehicle's battery in one to two days.

COMPONENT LOCATIONS

TIP

We recommend you do a “soft install” first by placing all components in their chosen locations, completing the setup instructions, and verifying the system works as desired. (Route the cable through an open door or window for the soft install.)

NOTE: It is up to the installer to determine the best component locations.

The outside antenna must be completely above the roof line.

Make sure the outside antenna does not exceed maximum vehicle height restrictions.

Locate outside antenna as far from metal obstructions as possible.

The mounting bracket allows the outside antenna to be mounted directly to the roof, or to a pole or ladder using the included pole mounting hardware.

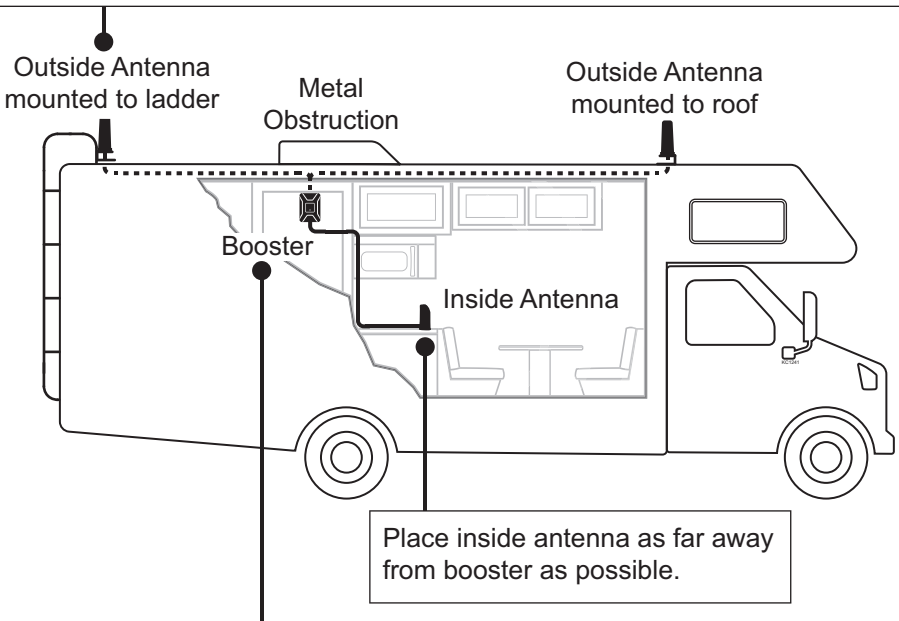

Mount booster as far away from outside antenna as possible, but make sure 20 foot cable will still reach between the two.

A convenient place to mount the booster is to the inside back of a cabinet near a 110 VAC power source. The booster can be oriented in any direction.

OUTSIDE ANTENNA MOUNTING OPTIONS

ANTENNA FASTENS TO BRACKET THE SAME WAY FOR OPTIONS 1 & 2

With either mounting option, the antenna fastens to the bracket with (2) supplied sets of washers and screws.

Fasteners to be determined by installer.

OPTION 1 Roof Mount

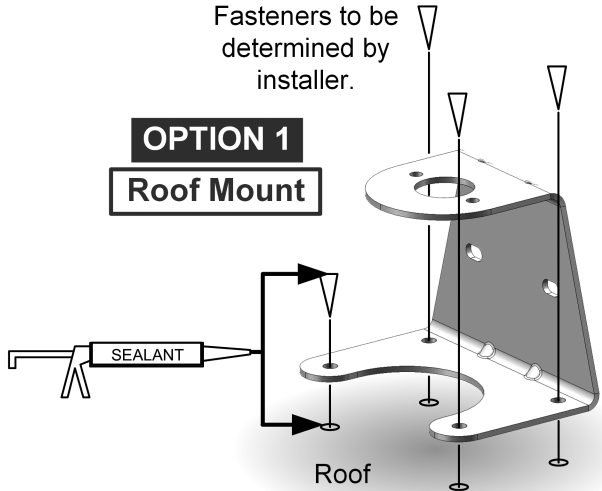

OPTION 2 Pole or Ladder Mount

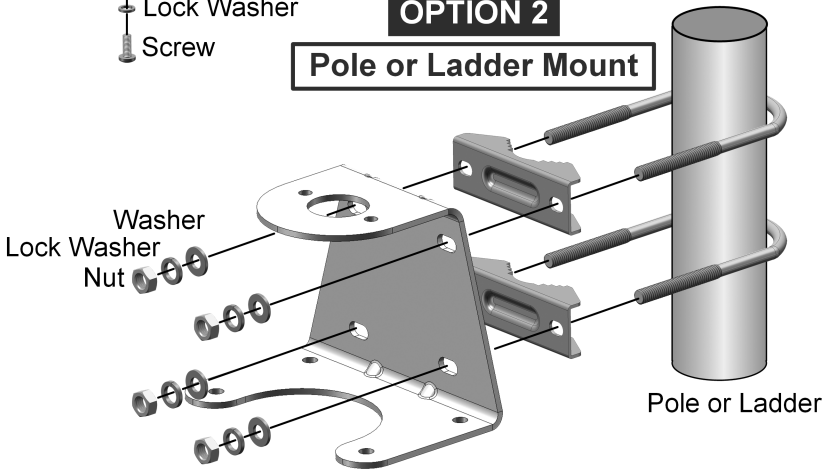

INSTALLATION

1. Fasten the outside antenna to the mounting bracket with the supplied screws and washers (see page 5).
2. Connect the separate 20' cable to the antenna (**LARGE CONNECTOR**).
3. Apply roof-compatible sealant around the areas where the bracket fasteners will penetrate the roof.
4. Fasten bracket to roof. Make sure fastener holes and fastener heads are properly sealed.

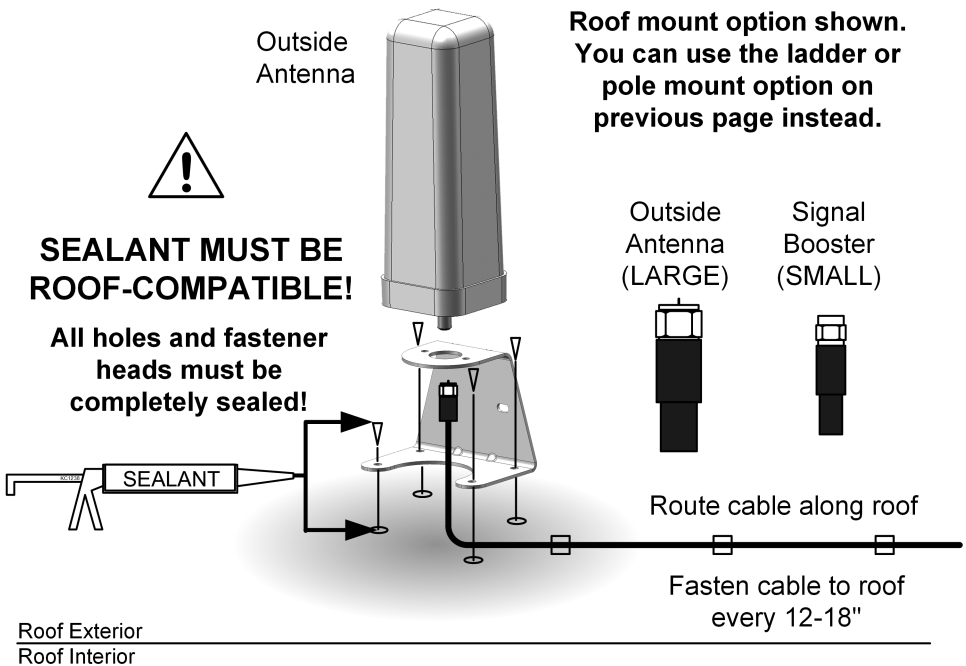

**AVOID SHARP BENDS
WHEN ROUTING COAX!**

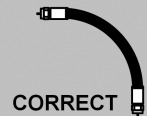
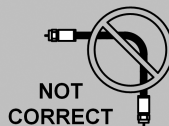

5. Route the cable to where it will enter the vehicle.

IMPORTANT! Make sure to avoid any cabling, pipes, etc. that may be damaged by drilling.

6. Drill an appropriately sized hole and feed the cable into the vehicle.

7. Seal the roof hole so it is completely waterproof (inside and outside).
Fasten cable to roof every 12-18.”

8. Inside, place booster in desired location or install the booster to wall.
Connect cable to booster.

9. Connect inside antenna cable to booster and place inside antenna in position.

10. Plug booster into power source.

The KING Cable Entry Cover provides additional protection against water intrusion.

See the satellite accessories page at kingconnect.com

TIP

If using the included booster mounting bracket, remove the booster from the bracket. Fasten bracket to wall, then snap booster back into bracket.



SEALANT MUST BE ROOF-COMPATIBLE!
Seal hole (inside and outside)
so it is completely waterproof!

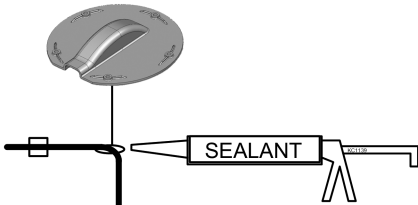

Signal
Booster

**KEEP AS FAR APART
AS POSSIBLE**

Inside
Antenna



Cable comes attached to inside antenna



110 VAC

MEASURING BOOSTER PERFORMANCE

Put your cell phone in field test mode and determine the signal inside your vehicle.

Note it here:

iPhone®

Dial *3001#12345#* then press Call.

- 1 Hold down power button until you see “Slide to Power Off.”
- 2 Release the power button.
- 3 Hold the Home button until your main screen appears.

If you want to check 3G/1x but your iPhone is picking up 4G/LTE signal , go to Settings>Cellular>Cellular Data Options>Enable LTE>Select Off.

After your system is set up, you can go back to the dots signal by once again dialing *3001#12345#* then pressing call. When the menu comes back up, tap “phone” in the top left corner of your phone.

iPhone® IOS 11 - current

IOS 11 no longer displays the decibel (dBm) reading in “Field Test Mode.” Tip: Using the bar indicator on your cell phone can assist you in finding the strongest signal direction as well as placing calls in different locations. For changes/updates on this issue, periodically go to weboost.com/signalstrength.

Android™

Settings>About Phone>Status or Network>Signal strength or Network Type and Strength (exact options/wording depends on phone model).

All Other Phones and Alternate Methods

- <https://www.weboost.com/test-mode-instructions/>

All Phones:

- Keep track of the network (3G or 4G) the phone is connected to.
- Any signal readings you take are valid for that phone's carrier. To get readings from other carriers, you will need phones from each carrier.
- When the system is set up, you can easily revert back to the "bar display" by dialing *3001#12345#* and pressing Call. Press the signal strength at the top left of the screen to toggle between numbers and bars. Press the Home button to exit Field and Test mode.

Compare Results

Having an accurate measurement of signal strength in decibels (dBm) is crucial when installing your system. Decibels accurately measure the signal strength you are receiving.

SIGNAL STRENGTH	EXCELLENT	GOOD	FAIR	POOR	DEAD ZONE
3G/1x	-70dBm	-71 to -85dBm	-86 to -100dBm	-101 to -109dBm	-110dBm
4G/LTE	-90dBm	-91 to -105dBm	-106 to -110dBm	-111 to -119dBm	-120dBm

Did you know a signal increase of just 3dB is 2 times the power of signal amplification?

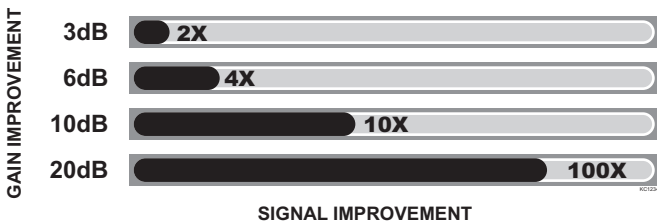

SIGNAL BOOSTER STATUS LIGHT

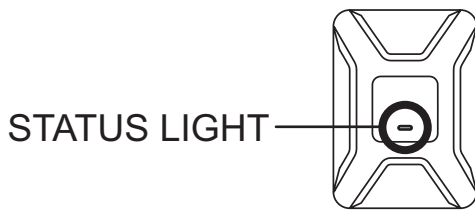

SOLID GREEN

This indicates your booster is functioning properly and there are no issues with installation.

BLINKING RED, THEN SOLID GREEN

This indicates one or more of the booster bands has reduced power due to a feedback loop condition called oscillation. This is a built-in safety feature to prevent harmful interference with a nearby cell tower. If you are already experiencing the desired signal boost, then no further adjustments are necessary. If you are not experiencing the desired boost in coverage, then refer to the troubleshooting section on the next page.

SOLID RED

This is due to a feedback loop condition called oscillation. This is a built-in safety feature that causes a band to shut off to prevent harmful interference with a nearby cell tower. Refer to the troubleshooting section on the next page.

LIGHT OFF

If the signal booster light is off, verify your power supply has power.

NOTE: The signal booster can be reset by disconnecting and reconnecting the power supply.

After troubleshooting, you must initiate a new power cycle by disconnecting and then reconnecting power to the signal booster.

TROUBLESHOOTING

FIXING BLINKING OR SOLID RED ISSUES

This section is only applicable if the booster is red or blinking red and you are not experiencing the desired signal boost.

1. Unplug the signal booster's power supply.
2. Relocate the inside and outside antenna further away from each other. The objective is to increase the separation distance between them, so that they will not create this feedback condition discussed before.
3. Plug power supply back in.
4. Monitor the indicator light on your signal booster. If after a few seconds of "power on", a solid blinking red light appears, repeat steps 1 through 3. Increase the separation distance until the condition is corrected and/or desired coverage area is achieved. NOTE: Horizontal separation of the two antennas typically requires a shorter separation distance than perpendicular separation.

If you are having any difficulties while testing or installing your booster, call KING Customer Service at (952) 345-8147.

SPECIFICATIONS

Product Number	U470010					
Model Number	460021					
FCC ID:	PWO460021					
IC:	4726A-460021					
Connectors	SMA-Female					
Antenna Impedance	75 Ohms					
Frequency	699-716 MHz, 729-756 MHz, 777-786 MHz, 824-894 MHz, 1850-1995 MHz, 1710-1755 MHz/2110-2155 MHz					
Passband Gain (nominal)	700 MHz Band 12/17 45.8	700 MHz Band 13 46.8	800 MHz Band 5 46.8	1700/2100 MHz Band 4 45.2	1900 MHz Band 2 44.6	
20 dB Bandwidth (MHz)	700 MHz Band 12/17	700 MHz Band 13	800 MHz Band 5	1700/2100 MHz Band 4	1900 MHz Band 2	
	Typical	30.6	31.0	37.9	79.2	77.3
	Maximum	35.2	35.2	39.9	79.8	83.2
Maximum Power						
Power output for single cell phone (uplink) dBm	700 MHz Band 12/17 24.84	700 MHz Band 13 24.35	800 MHz Band 5 23.4	1700 MHz Band 4 21.3	1900 MHz Band 2 24.43	
Power output for single cell phone (Downlink) dBm	700 MHz Band 12/17 2.87	700 MHz Band 13 2.79	800 MHz Band 5 2.8	2100 MHz Band 4 2.0	1900 MHz Band 2 1.92	
Maximum Power						
Power output for multiple received channels (Uplink) dBm	No. Tones	700 MHz Band 12/17	700 MHz Band 13	800 MHz Band 5	1700 MHz Band 4	1900 MHz Band 2
	2	25.4	23.9	22.9	22.8	24.9
	3	21.8	20.4	19.4	19.3	21.3
	4	19.3	17.9	16.9	16.8	18.8
	5	17.4	16.0	15.0	14.8	16.9
	6	15.8	14.4	13.4	13.2	15.3
Maximum Power						
Power output for multiple received channels (Downlink) dBm	No. Tones	700 MHz Band 12/17	700 MHz Band 13	800 MHz Band 5	2100 MHz Band 4	1900 MHz Band 2
	2	4.8	5.6	5.4	6.3	4.5
	3	1.3	2.1	1.9	2.8	0.9
	4	-1.2	-0.4	-0.6	0.3	-1.6
	5	-3.2	-2.4	-2.6	-1.6	-3.5
	6	-4.7	-4.0	-4.2	-3.2	-5.1
Noise Figure	5 dB nominal					
Isolation	>90 dB					
Power Requirements	6 V 2 A					

10/07

(SPECIFICATIONS cont.)

The term "IC" before the radio certification number only signifies that Industry Canada technical specifications were met.

Each signal booster is individually tested and factory set to ensure FCC compliance. The signal booster cannot be adjusted without factory reprogramming or disabling the hardware. The signal booster will amplify, but not alter incoming and outgoing signals in order to increase coverage of authorized frequency bands only. If the signal booster is not in use for five minutes, it will reduce gain until a signal is detected. If a detected signal is too high in a frequency band, or if the signal booster detects an oscillation, the signal booster will automatically turn the power off on that band. For a detected oscillation the signal booster will automatically resume normal operation after a minimum of one minute. After five such automatic restarts, any problematic bands are permanently shut off until the signal booster has been manually restarted by momentarily removing power from the signal booster. Noise power, gain, and linearity are maintained by the signal booster's microprocessor.

The manufacturer's rated output power of this equipment is for single carrier operation. For situations when multiple carrier signals are present, the rating would have to be reduced by 3.5 dB, especially where the output signal is re-radiated and can cause interference to adjacent band users. This power reduction is to be by means of input power or gain reduction and not by an attenuator at the output of the device.

This device complies with Part 15 of FCC rules. Operation is subject to two conditions: (1) This device may not cause harmful interference, and (2) this device must accept any interference received, including interference that may cause undesired operation. Changes or modifications not expressly approved by weBoost could void the authority to operate this equipment.

SAFETY GUIDELINES

Use only the power supply provided in this package. Use of any other product may damage your equipment.

The signal booster unit is designed for use in an indoor, temperature-controlled environment (less than 150 degrees Fahrenheit). It is not intended for use in attics or similar locations subject to temperatures in excess of this range.

The desktop antenna must have at least 3 feet of separation distance from all active users. All inside panel and dome antennas must have at least 6 feet of separation distance from all active users, and low profile antennas must have at least 1.5 feet of separation distance from all active users.

Connecting the signal booster directly to the cell phone with use of an adapter will damage the cell phone.

RF Safety Warning: Any antenna used with this device must be located at least 8 inches from all persons.

AWS Warning: The outside antenna must be installed no higher than 31 feet 9 inches (10 meters) above ground.

This is a CONSUMER device.

BEFORE USE, you **MUST REGISTER THIS DEVICE** with your wireless provider and have your provider's consent. Most wireless providers consent to the use of signal boosters. Some providers may not consent to the use of this device on their network. If you are unsure, contact your provider.

In Canada, **BEFORE USE** you must meet all requirements set out in ISED CPC-2-1-05. You **MUST** operate this device with approved antennas and cables as specified by the manufacturer. Antennas **MUST** be installed at least 20 cm (8 inches) from (i.e., **MUST NOT** be installed within 20 cm of) any person.

You **MUST** cease operating this device immediately if requested by the FCC (or ISED in Canada) or licensed service provider.

WARNING: E911 location information may not be provided or may be inaccurate for calls served by using this device.

FOR MORE INFORMATION ON REGISTERING YOUR SIGNAL BOOSTER WITH YOUR WIRELESS PROVIDER, PLEASE SEE BELOW:

Sprint: http://www.sprint.com/legal/fcc_boosters.html

T-Mobile/MetroPCS: <https://support.t-mobile.com/docs/DOC-9827>

Verizon Wireless: <http://www.verizonwireless.com/wcms/consumer/register-signal-booster.html>

AT&T: <https://securec45.securewebsession.com/attsignalbooster.com/>

U.S. Cellular: <http://www.uscellular.com/uscellular/support/fcc-booster-registration.jsp>

WARRANTY

KING Signal Boosters are warranted for two (2) years against defects in workmanship and/or materials. Should any trouble develop during the warranty period, contact KING at (952) 345-8147. You must contact KING before the warranty period expires. The customer must supply proof of purchase (such as a dated sales receipt) when requesting warranty service. If the customer cannot supply proof of purchase, warranty period shall start 30 days after date of manufacture.

Warranty claims for KING Signal Boosters are processed by Wilson Electronics ("Wilson") according to the warranty policy outlined below.

Warranty cases may be resolved by returning the product directly to the reseller with a dated proof of purchase [NOTE: Needs to be discussed]. Signal Boosters may also be returned directly to the manufacturer at the consumer's expense, with a dated proof of purchase and a Returned Material Authorization (RMA) number supplied by Wilson. KING and Wilson shall, at their option, either repair or replace the product.

This warranty does not apply to any Signal Boosters determined by KING or Wilson to have been subjected to misuse, abuse, neglect, or mishandling that alters or damages physical or electronic properties. Replacement products may include refurbished Wilson products that have been recertified to conform with product specifications. RMA numbers may be obtained by contacting KING Customer Support at (952) 345-8147.

In no event shall KING be liable for any indirect, incidental, or consequential damages from the sale or use of the product. This disclaimer applies both during and after the term of this warranty.

KING disclaims liability for any implied warranties, including implied warranties of "merchantability" and "fitness for a specific purpose," after the term of this warranty.

This warranty gives you specific legal rights, and you may also have other rights, which vary from state to state. Some states do not allow the exclusion or limitation of incidental or consequential damages, so the above limitation or exclusion may not apply to you. Some states do not allow limitations on how long an implied warranty lasts, so the above limitation may not apply to you.

DISCLAIMER: The information provided is believed to be complete and accurate. However, no responsibility is assumed by KING or Wilson for any business or personal losses arising from its use, or for any infringements of patents or other rights of third parties that may result from its use.

Simply better, by design.™



This product is covered by U.S. patent(s) and pending application(s).
For patents go to: weboost.com/us/patents.

NOT AFFILIATED WITH WILSON ANTENNA

All trademarks are the sole property of their respective owners.

23525 Rev A © 2019 KING