

# **▶KING** || **ONE<sup>PRO</sup>**<sup>™</sup>

---

---

## **KOP4800 Installation Guide**

**This guide contains installation and safety information  
for your KING One Pro.**

**Please read thru this guide before using or installing  
your KING One Pro.**



**QUESTIONS? (952) 345-8147**



## IMPORTANT SAFETY INFORMATION

1. Please read this safety information thoroughly before using or installing the KING One Pro.
2. Keep this safety information and the included Quick Reference Guide in a safe place for future reference.
3. Follow all instructions and warnings. Set up, operate and install (optional) the KING One Pro in accordance with the instructions.
4. Do not submerge the KING One Pro or place in standing water. Hand wash only with mild soap and water.
5. Do not operate or store near any indoor or outdoor heat source such as radiators, heat registers, stoves, barbecues, campfires, or other items that produce heat.
6. Servicing may be required if the unit has been dropped or damaged in any way or if the unit does not operate normally. Call KING Customer Service at (952) 345-8147.
7. Tighten all of the coax cable connections only by hand. If you use a wrench, you may over-tighten the connections and damage your equipment.
8. To avoid risk of electrical shock, unplug your receiver before connecting/disconnecting the KING One Pro in damp or wet conditions.
9. Always handle the KING One Pro carefully. Do not drop the KING One Pro. Avoid excessive shock or vibration to the KING One Pro.
10. Use caution when carrying the KING One Pro. Always carry the KING One Pro by the handle.
11. Do not remove the cover of the KING One Pro without authorization. Doing so will void the limited warranty.
12. Do not stack the KING One Pro on top of or below other electronic devices as this can cause heat build-up or block the satellite signal from reaching the KING One Pro.
13. Keep the enclosure clean from dirt, bugs, and other debris by hand washing with mild soap and water.
14. Do not coat or paint the KING One Pro with any substance.
15. The KING One Pro has been designed to be maintenance and trouble free. If not using the KING One Pro for long periods of time, it is recommended that you set up the system on a quarterly basis (every three months) to keep all moving parts of the KING One Pro in good working order.
16. The KING One Pro can be secured to an object by looping a cable (sold separately) thru the handle and attaching the cable to a secure object.



**DO NOT OVER-TIGHTEN COAX CONNECTIONS.**



**DO NOT POWER WASH THE ANTENNA UNIT.**

If you have any comments or questions, please contact KING Customer Service at (952) 345-8147, or by email at [help@kingconnect.com](mailto:help@kingconnect.com).

## OPTIONAL MOUNTING ACCESSORIES

Although the antenna unit is designed to be mounted directly to the roof, the following two options are also available.

### MB160

Mounting Bracket

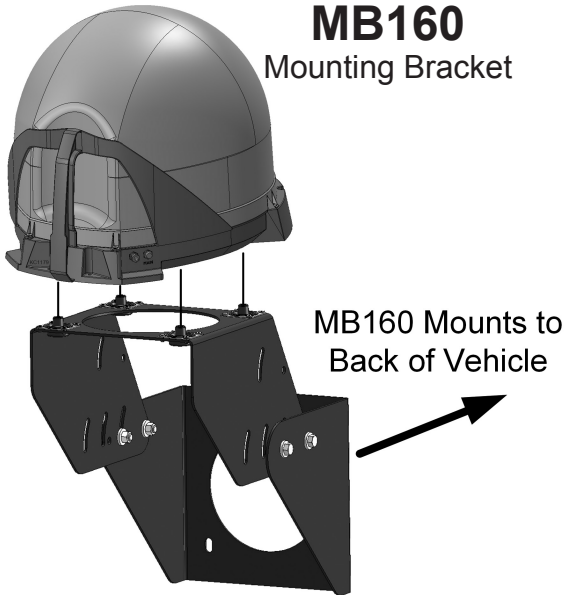

The KING One Pro is not compatible with the MB100 Mounting Bracket. Use of MB100 will void warranty.

The use of any unauthorized mounting bracket will void warranty.

### MB700

Quick Release Roof-Mount Kit

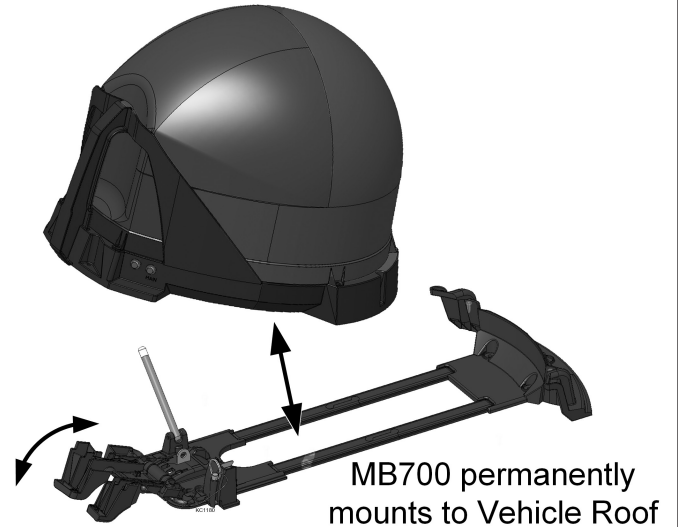

Allows you to easily use the antenna unit as either a roof-mounted or portable antenna.

For temporary use when you don't want to put the antenna unit on the ground, KING offers these two options.

### TR1000

Tripod Mount

Allows you to position your KING One Pro almost anywhere for best line of sight to satellite. Keeps antenna off the ground away from moisture.



### MB500

Mounting Bracket

Includes (2) Hanger Brackets

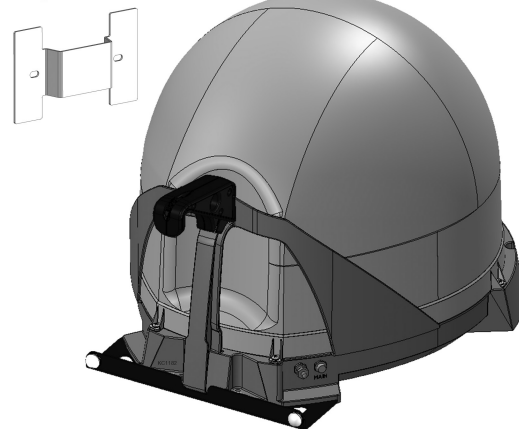

Allows hanging of antenna unit on vehicle window or included hanger bracket.

For stationary use only. Vehicle must not be in motion while antenna unit is on window or hanger bracket.

See your dealer or the satellite antenna accessories page at [kingconnect.com](http://kingconnect.com) for details. KING antenna not included with purchase of these products.

••••• **IMPORTANT POINTS!** •••••



The installer is responsible for determining the most appropriate fasteners to secure the antenna unit to the roof. Depending on the roof material, fasteners such as lag screws, well nuts, sheet metal screws, toggle bolts and T anchors may be used, and should always be used in combination with a **roof-compatible** sealant.



The installer is responsible for properly securing the coax cable to the roof (for example, cable ties and cable tie mounting pads).



The installer is responsible for weatherproofing all holes (except drain holes in base) with **roof-compatible** sealant.



If the rubber feet have been installed, remove them from the bottom of the unit. **DO NOT INSTALL UNIT ON ROOF WITH RUBBER FEET IN PLACE.**

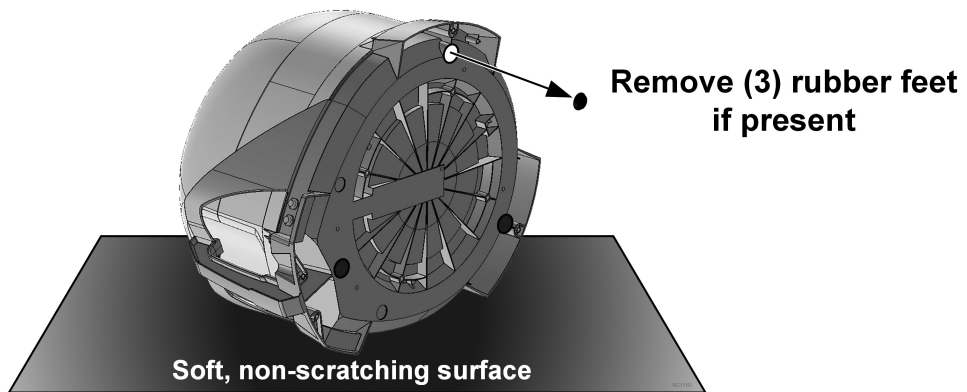

Do not put sharp bends in coax cables. This can reduce signal strength from the antenna.

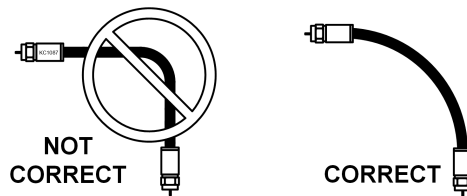

You can cut the coax to length but you must terminate the coax with Snap-n-Seal connectors. Otherwise, bundle and store excess coax in cabinet with receiver.

**SNAP-N-SEAL® CONNECTOR**



**Thomas and Betts part # SNS 1P6**

**CRIMPER**

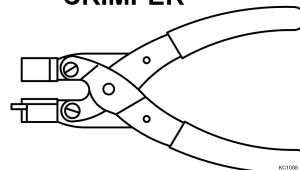

**Thomas and Betts part # SNSUTL**

Connector and crimper sold separately.

## ITEMS YOU WILL NEED

### In the KING One Pro box:

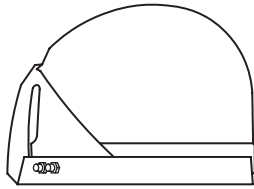

Antenna Unit



Power Inserter  
with Power Supply



Short Coax Cable



50' RG-6  
Coax Cable



(3) Rubber Feet

Do not use rubber feet.  
If installed on antenna unit,  
remove before mounting.

### Additional Items (sold separately):

Programming  
Subscription 

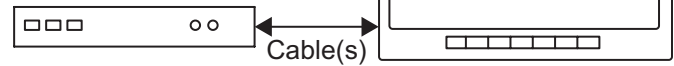

Receiver compatible  
with your service\*

\*Some DIRECTV receivers require additional  
components to enable satellite signal reception (page 9).

Visit [kingconnect.com/support](http://kingconnect.com/support) for additional receiver  
compatibility information.

You will also need a drill and drill bits, roof-compatible sealant, and appropriate fasteners to install all components and wiring.

The CE2000 Cable Entry Cover (sold separately) provides a watertight seal where cables penetrate the roof (see the satellite antenna accessories page at [kingconnect.com](http://kingconnect.com) for more information).

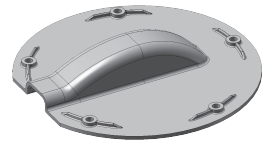

## ANTENNA UNIT LOCATION

**END-USER INSTALLATIONS:** Many RVs are prewired with RG-6 coax cable for satellite antennas. Contact the manufacturer of your RV or your local dealer to verify where this cable is located.

If prewired, run the existing coax cable from the prewired location in the roof to the antenna unit. When choosing the antenna unit location, make sure the prewiring will reach the antenna unit.

1. Select an area on the roof for the antenna unit and the location where the wiring will enter the vehicle through the roof to the satellite receiver inside using the following criteria:
  - A shorter distance between the antenna unit and the satellite receiver is most desirable.
  - Make sure you have enough room to mount the antenna unit.
  - The antenna unit should be mounted on the center line of the vehicle, and not tilted more than 2 degrees in any direction.
  - There must be no line of sight obstructions. Air conditioning units, other antennas, and storage areas that are too close to the antenna unit may prevent the satellite signal from reaching the antenna unit.
  - Mount the antenna unit with the handle to rear of the vehicle.

# ANTENNA UNIT LOCATION

HEIGHT OF OBSTRUCTION	APPROXIMATE MINIMUM DISTANCE TO EDGE OF ANTENNA UNIT
10"	8"
11"	10"
12"	12"
13"	14"
14"	16"
15"	18"
16"	20"

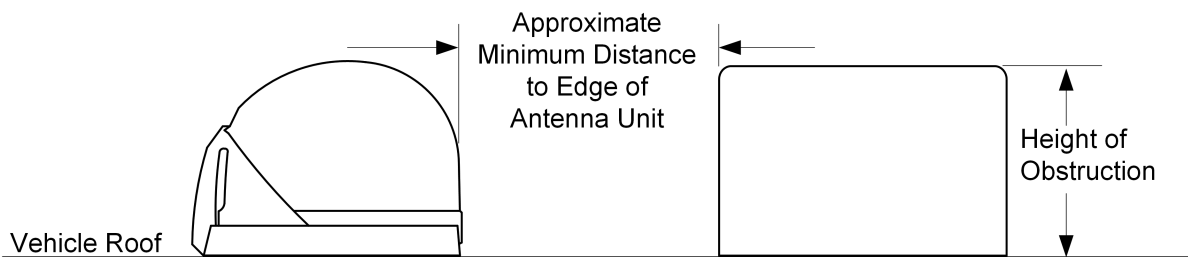

**Do not mount antenna unit too close to obstructions.**

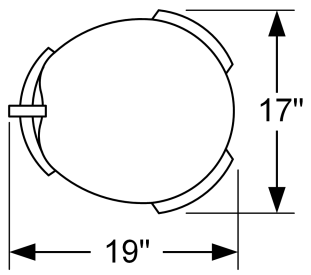

**Choose a location with adequate space.**

**Mount antenna unit on center line of vehicle.**

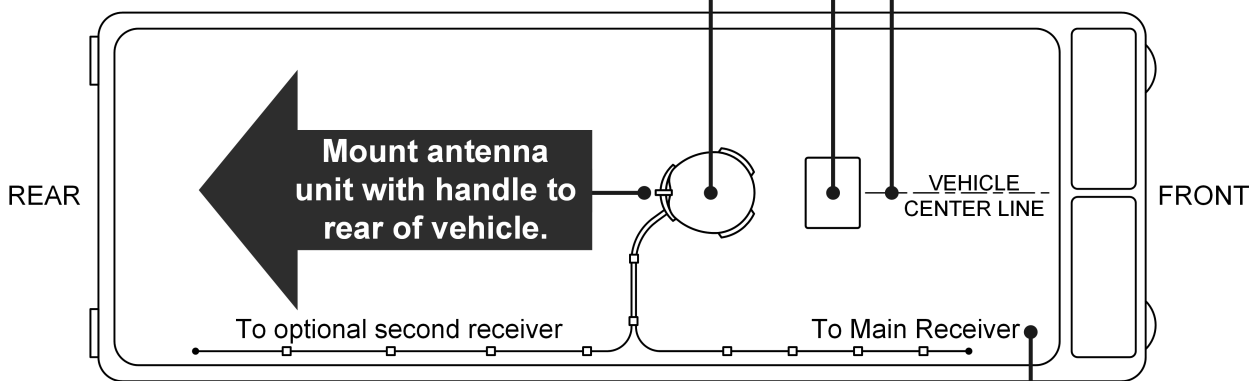

**Try to install antenna unit as close as possible to main receiver to minimize coax length.**

## ANTENNA UNIT MOUNTING



IF INSTALLED, REMOVE THE (3) RUBBER FEET FROM THE BOTTOM OF THE ANTENNA UNIT. DO NOT ROOF MOUNT ANTENNA UNIT WITH FEET IN PLACE.



MAKE SURE YOU READ AND UNDERSTAND ALL OF THE IMPORTANT POINTS ON PAGE 3 BEFORE BEGINNING THE INSTALLATION.

- Apply **roof-compatible** sealant to roof around entire area where fasteners will penetrate the roof. Mount the antenna unit using the (4) mounting holes. After mounting unit, seal fastener heads with **roof-compatible** sealant.

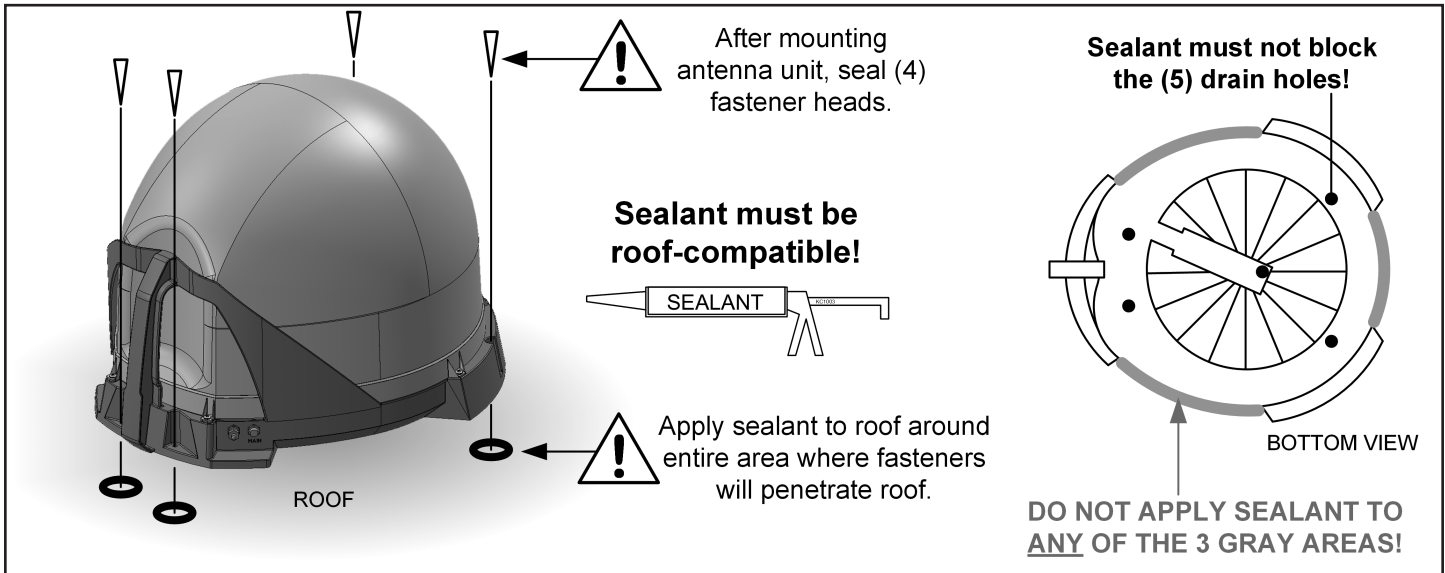

## COAX ROUTING

There are two coax ports on the back of the antenna unit. The one labeled "MAIN" **MUST** be connected to the KING power inserter. The AUX port can be used for an additional receiver, or for DIRECTV SWM installations. Review the wiring diagrams on pages 8-9 before routing your coax.

- Connect one end of the RG-6 coax cable to the MAIN port and tighten connection (see below). **DO NOT OVER-TIGHTEN.**

If using a second receiver, connect one end of second RG-6 coax (sold separately) to the AUX port. Tighten connection. **DO NOT OVER-TIGHTEN.**

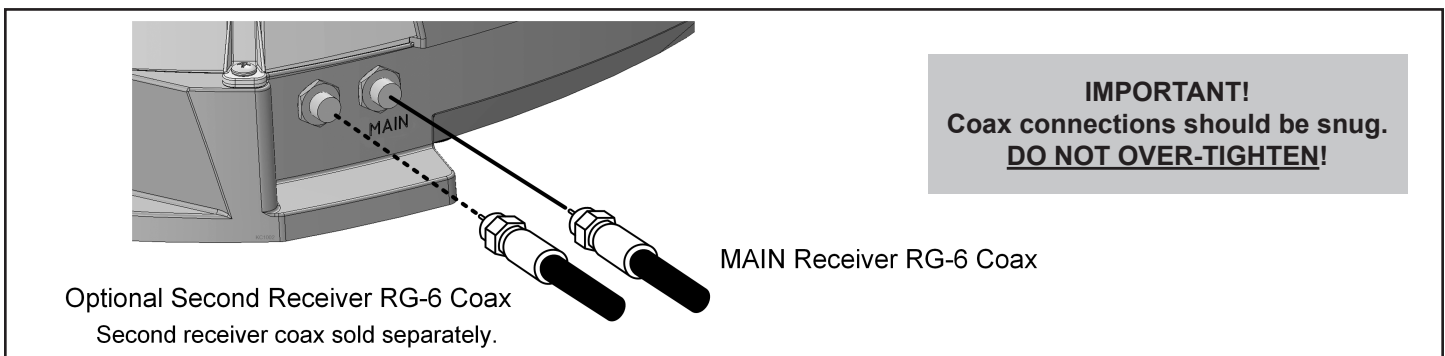

## AVOID SHARP BENDS WHEN ROUTING COAX!

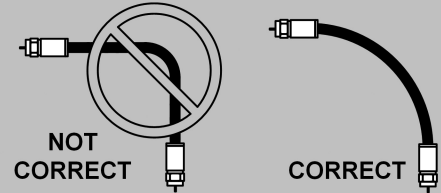

- Run coax from the antenna unit to the roof edge, then along edge to location where coax will be fed into the vehicle. If installing an optional second receiver, run second coax to location where it will enter the vehicle. Secure (both) coax to roof every 12-18 inches (see below).
- Drill 3/4" hole through the roof and into the cabinet where receiver is stored. Feed coax down through hole. Seal opening with roof-compatible sealant so that it is completely waterproof (inside and outside of the 3/4" hole). Repeat for second coax if present.

## TYPICAL ROOF INSTALLATION - OVERHEAD VIEW

Installer is responsible for determining proper roof-compatible sealant.

All holes for cables and fasteners must be sealed so they are completely waterproof.

AVOID SHARP BENDS  
WHEN ROUTING COAX!

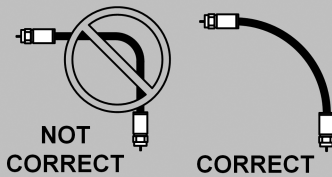

### OPTIONAL: OEM INSTALLATION AND END-USERS WITH CABLE ENTRY COVER:

Fasten cable entry cover to roof with appropriate sealant and roof fasteners.

#### IMPORTANT!

Installer is responsible for  
determining proper fasteners.

Mounting holes, perimeter of cable  
entry cover and cable opening of  
cable entry cover must be sealed  
so they are completely waterproof.

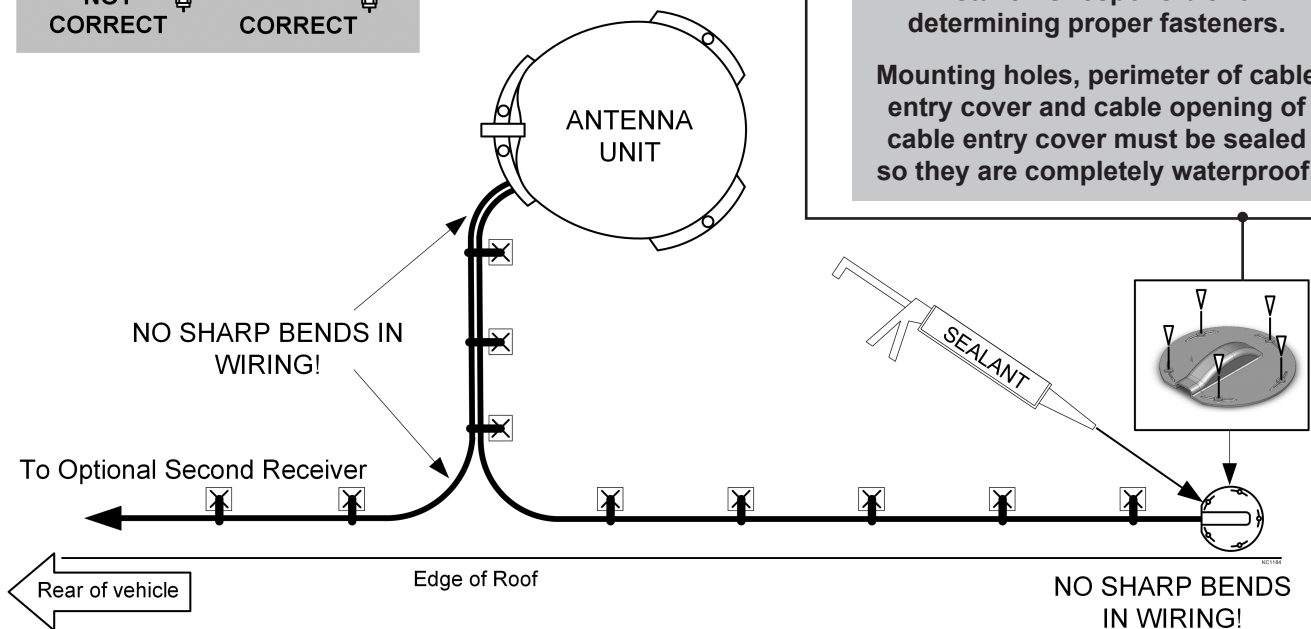

- Make interior connections shown on next page.

# INTERIOR CONNECTIONS: DISH®, BELL™ AND DIRECTV®

Use this page for DISH, Bell, and DIRECTV connections.

**IMPORTANT!** If you have a DIRECTV receiver H/HR25 or higher, make the connections shown on page 9 (requires DSWM30 Kit - sold separately).



**HAND-TIGHTEN COAX. OVER-TIGHTENING CAN DAMAGE CONNECTIONS.**

**AVOID SHARP BENDS WHEN ROUTING COAX!**

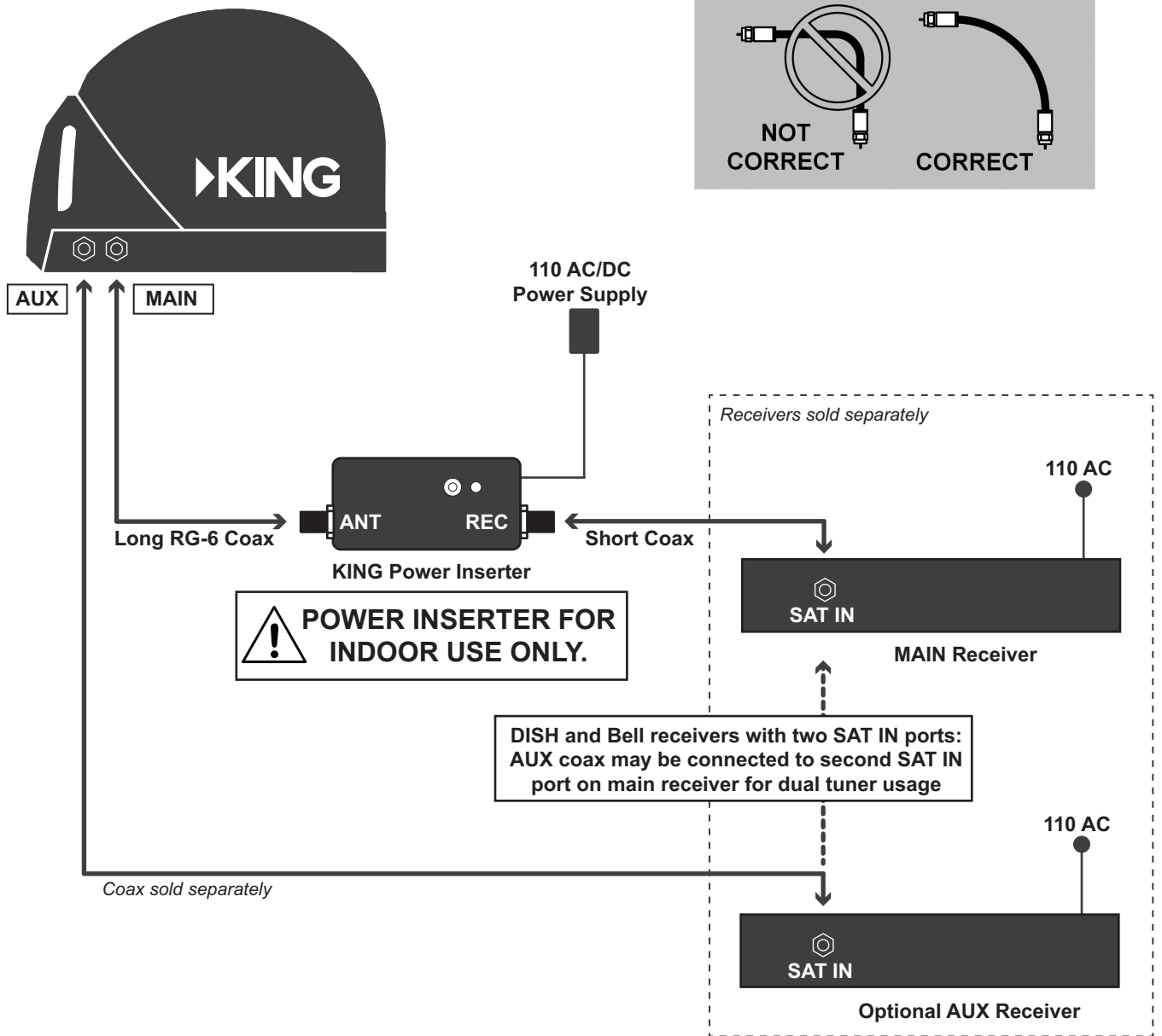
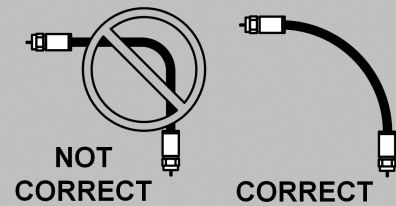

**IMPORTANT! DIRECTV receivers H/HR25 and higher require use of components shown below.**

**NOTE:** When using this connection diagram, you will not receive programming from the 119 satellite.



**DO NOT** use DSWM30H or your receiver may be damaged.

DSWM30 is compatible with H21 or later receivers and HR20 or later DVRs. It is not compatible with D12 receivers.

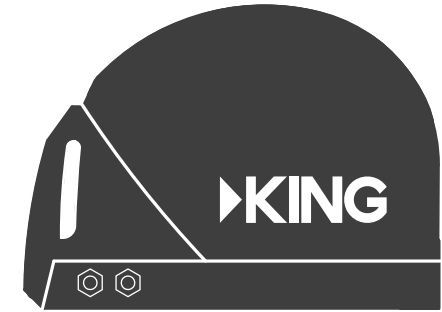
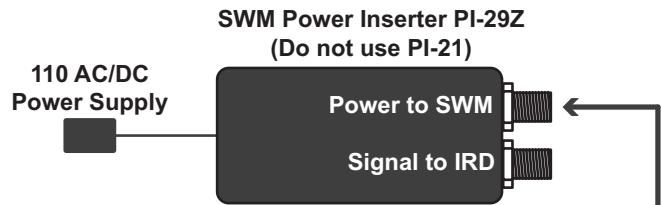

Not more than 100 ft of total RG-6 coax between antenna and DSWM30

For access to 101° satellite programming, connect the MAIN and AUX ports of the antenna to both LNB inputs labeled Sat 99°/101°

**CONNECT COAX TO PROPER INPUTS!**  
**MAIN TO 18V**  
**AUX TO 13V**

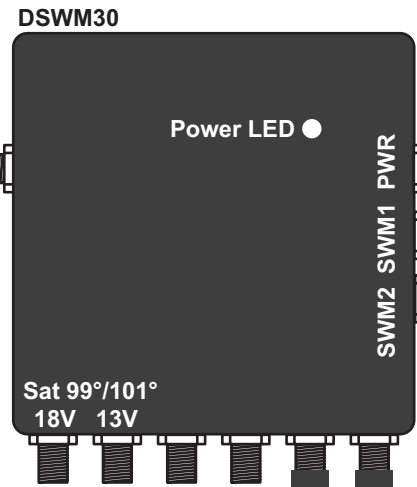
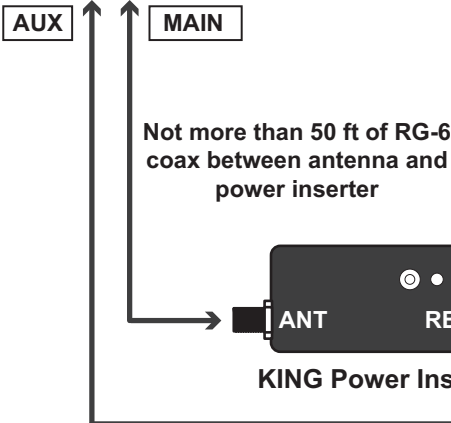

Unused SWM outputs: screw on dust cap (no center pin)

Not necessary if DSWM30 is used in dry conditions



**POWER INSERTER FOR INDOOR USE ONLY.**

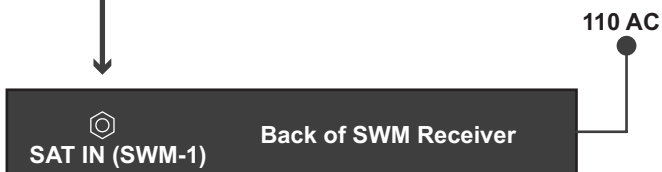

Receivers can be non-DVR or DVR receivers\*\*

\*\*If connecting to a DVR receiver, do not connect a coaxial cable to the Satellite 2 input. With SWM, only connect to the Satellite 1 port (labeled FTM or SWM)

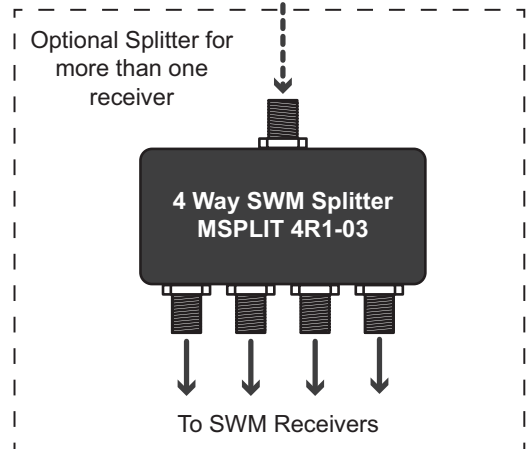

All items other than KING Antenna, KING Power Inserter (with power supply), 50' coax, and short coax sold separately.

**Simply better, by design.™**



---

11200 Hampshire Avenue South, Bloomington, MN 55438  
PH 952.922.6889 || FAX 952.922.8424 || [kingconnect.com](http://kingconnect.com)

© KING 2018      23359 Rev A

Trademarks are the sole property of their respective owners.

# ▶KING || ONE<sup>PRO</sup><sup>™</sup>

---

---

## KOP4800 Owner's Manual



For use with **DIRECTV<sup>®</sup>** satellite programming

### **IMPORTANT!**

The KING One Pro works with DIRECTV, DISH, and Bell TV. This manual is for DIRECTV subscribers. Manuals for DISH and Bell subscribers are available at [kingconnect.com](http://kingconnect.com). Do not use this manual if you are a DISH or Bell subscriber.



## IMPORTANT!

The satellite TV market is expanding and changing. The information in this manual was accurate at the time of printing. If your KING One Pro Satellite Antenna does not operate as outlined in this manual, please call KING® at (952) 345-8147 or visit our website at [kingconnect.com](http://kingconnect.com). KING is not responsible for changes outside of its control.

### PRODUCT REGISTRATION

To provide ongoing technical support and to better facilitate warranty processing, please register your product at [kingconnect.com/support](http://kingconnect.com/support).



## CONTENTS

INTRODUCTION .....	2-3
IMPORTANT SAFETY AND CARE INFORMATION .....	2
ABOUT SIGNAL LOSS .....	3
SECURITY .....	3
SETUP .....	4
CONTENTS .....	4
APPLY RUBBER FEET TO ANTENNA UNIT .....	4
CONNECTIONS .....	5-7
DIRECTV CONNECTIONS .....	6
DIRECTV CONNECTIONS WITH H/HR25 RECEIVER OR HIGHER .....	7
OPERATIONS .....	8-11
RECEIVER CONFIGURATION .....	8
ANTENNA CONFIGURATION .....	8-9
SCAN FOR SATELLITES .....	10-11
TROUBLESHOOTING .....	12
ACCESSORIES .....	13
LIMITED WARRANTY .....	14
FCC GUIDELINES .....	15

# INTRODUCTION

**Thank you for choosing the premium KING One Pro Portable HDTV System!**

The KING One Pro is factory programmed to work with DIRECTV. No antenna configuration is required. (The configuration process is shown on pages 8-9 for future reference.)

## IMPORTANT SAFETY AND CARE INFORMATION

1. Keep the Quick Reference Guide and Installation Guide that came with your KING One Pro in a safe place for future reference. You may also print this on-line manual and keep it for future reference as well.
2. Follow all instructions and warnings. Set up and operate the KING One Pro in accordance with the instructions.
3. To avoid risk of electric shock, unplug your receiver before connecting/disconnecting the KING One Pro in damp or wet conditions.
4. Tighten all of the coax cable connections by hand only. If you use a wrench, you may over-tighten the connections and damage your equipment.
5. Always handle the KING One Pro carefully. Do not drop the KING One Pro. Avoid excessive shock or vibration to the KING One Pro.
6. Use caution when carrying the KING One Pro. Always carry the KING One Pro by the handle.
7. Do not remove the cover of the KING One Pro without authorization. Doing so will void the limited warranty.
8. Do not stack the KING One Pro on top of or below other electronic devices as this can cause heat build-up or block the satellite signal from reaching the KING One Pro.
9. Do not operate or store near any indoor or outdoor heat source such as radiators, heat registers, stoves, barbecues, campfires, or other items that produce heat.
6. Servicing may be required if the unit has been dropped or damaged in any way or if the unit does not operate normally. Call KING Customer Service at (952) 345-8147.
10. Do not power wash the KING One Pro.
11. Do not submerge the KING One Pro or place in standing water.
12. Keep the enclosure clean from dirt, bugs, and other debris by hand washing with mild soap and water.
13. Do not coat or paint the KING One Pro with any substance.

The KING One Pro has been designed to be maintenance and trouble free. If not using the KING One Pro for long periods of time, it is recommended that you set up the system on a quarterly basis (every three months) to keep all moving parts of the KING One Pro in good working order.

If you have any comments or questions, please contact KING Customer Service at (952) 345-8147, or by email at [help@kingconnect.com](mailto:help@kingconnect.com).

**QUESTIONS? (952) 345-8147**

## ABOUT SIGNAL LOSS

### OBSTRUCTIONS

The KING One Pro requires an unobstructed view of the southern sky for the best signal reception.

Be sure to place the KING One Pro in a location free from obstructions such as people, trees, buildings, vehicles, etc. This will allow for the strongest signal and will help prevent any interruption to your programming. Pointing the handle approximately north may speed up scan time.

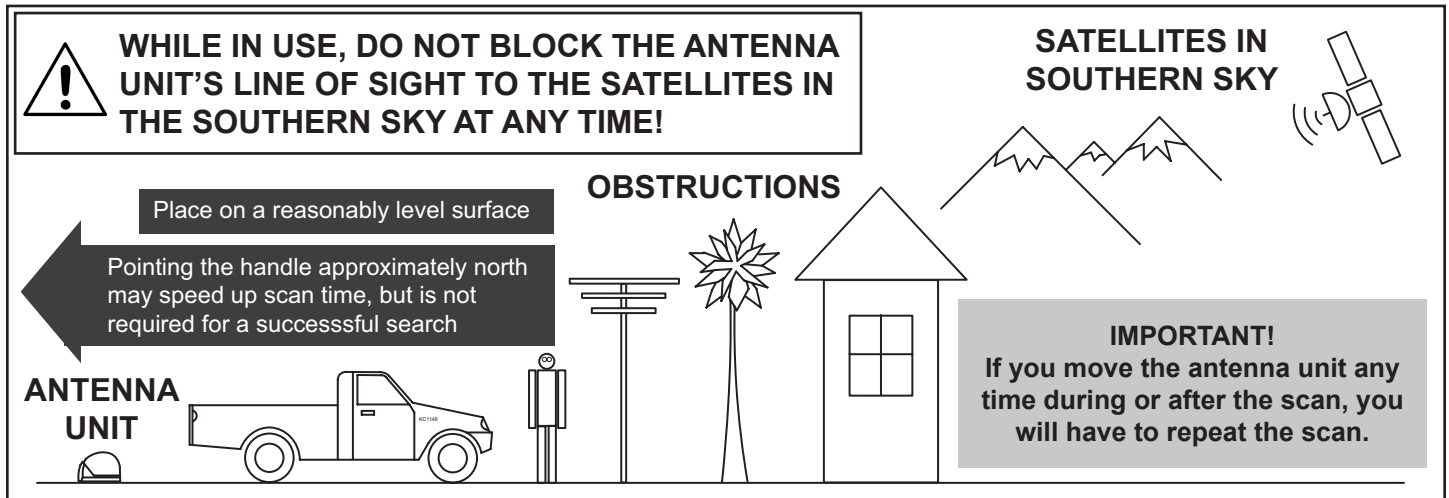

### RAIN AND SNOW FADE

Though rare, heavy rain, snow, or dense cloud cover can reduce the satellite signal, which may interrupt your programming. Your programming should return as conditions improve.

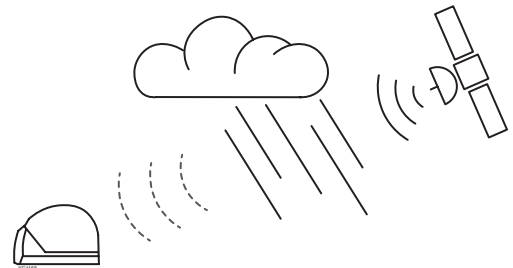

## SECURITY

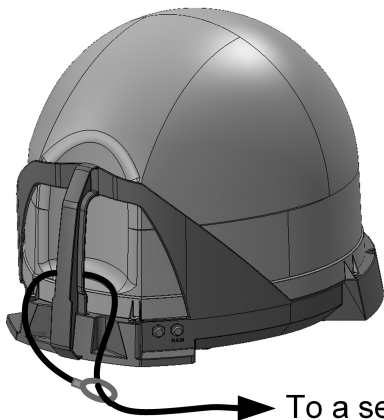

The KING Antenna can be secured to an object by looping a cable thru the handle.

Cable sold separately.

# SETUP

## CONTENTS

Antenna Unit

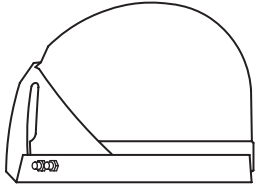

Power Inserter with Power Supply

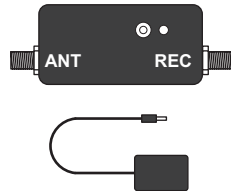

You will also need (sold separately):

DIRECTV  
Programming  
Subscription

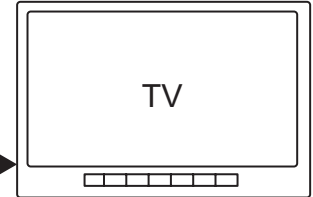

Cable(s)

DIRECTV Receiver

For the most up-to-date receiver compatibility information, go to [kingconnect.com/support](http://kingconnect.com/support)



Installation  
Guide

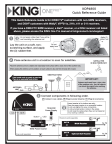

Quick  
Reference  
Guide



Registration  
Card

(3) Rubber  
Feet



50' RG-6  
Coax Cable



Short  
Coax Cable

## APPLY RUBBER FEET TO ANTENNA UNIT

### IMPORTANT!

Do not apply rubber feet if roof-mounting the antenna unit.  
See the Installation Guide included in the box.

Do not  
apply here.

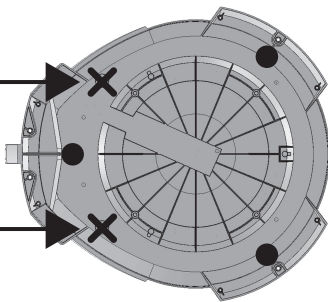

Apply (3)  
rubber feet

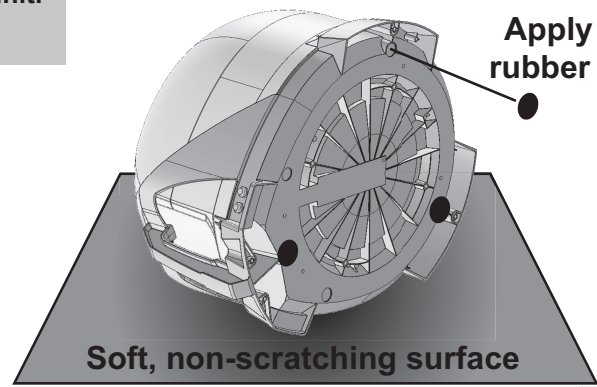

Soft, non-scratching surface

# CONNECTIONS

**NOTE:** If you wish to roof mount the antenna, see the Installation Guide that came with your KING One Pro.

**Make the connections on page 6 or page 7.**

**PAGE 6:** Make these connections unless you have an H/HR25 or higher receiver.

**PAGE 7:** Make these connections if you have an H/HR25 or higher receiver.  
(Requires DSWM30 Kit - sold separately)

**NOTE:** The KING One Pro will not receive channels broadcast from DIRECTV's Ka band satellites at 99° and 103°.

When using page 7 connection diagram, you will not receive programming from the 119 satellite.

## ••••• IMPORTANT POINTS! •••••

**Connect all coax cables first. Plug in power inserter and then receivers.  
Power inserter is for indoor use only.**



Place the power inserter in an accessible location.

Do not over-tighten the coax connections.

Do not put sharp bends or kinks in the cables.

Do not route the cables where they can be tripped on or run over by a vehicle.



**HAND-TIGHTEN COAX.  
OVER-TIGHTENING CAN  
DAMAGE CONNECTIONS.**

**AVOID SHARP BENDS WHEN ROUTING COAX!**

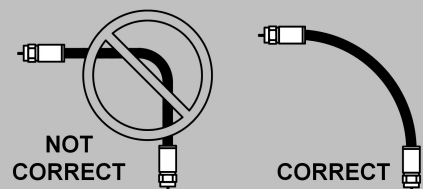

**After connecting and plugging in all components, wait for the power inserter LED to start flashing orange (about 10 seconds).**

**Go to page 8.**

# DIRECTV CONNECTIONS



**HAND-TIGHTEN COAX. OVER-TIGHTENING CAN DAMAGE CONNECTIONS.**

**AVOID SHARP BENDS  
WHEN ROUTING COAX!**

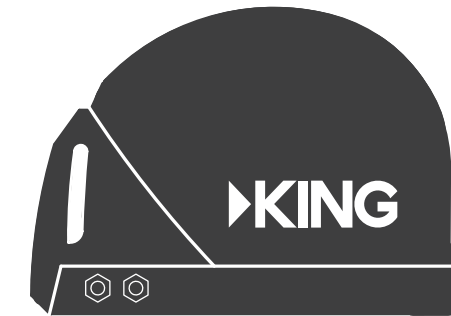
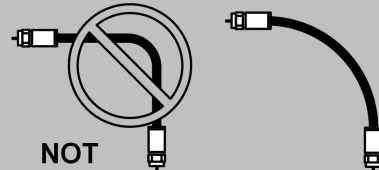

AUX

MAIN

110 AC/DC  
Power Supply

50' RG-6 Coax

Short Coax

KING Power Inserter

*Receivers sold separately*

110 AC

SAT IN

MAIN Receiver

110 AC

SAT IN

Optional AUX Receiver



**POWER INSERTER FOR  
INDOOR USE ONLY.**

*Coax sold separately*

Second receiver must be configured the same as the main receiver (see operation section).

Second receiver must be the same as main receiver (SWM vs. non-SWM).

If your main receiver has a second "satellite in" port and built in DVR, you can connect this input to the AUX port to record programs on a different channel than the one you are watching.

# DIRECTV CONNECTIONS WITH H/HR25 RECEIVER OR HIGHER



**DO NOT** use DSWM30H or your receiver may be damaged.

DSWM30 is compatible with H21 or later receivers and HR20 or later DVRs. It is not compatible with D12 receivers.

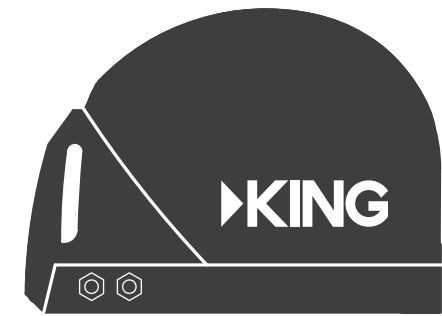
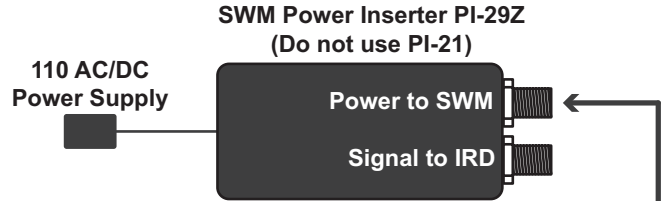

Not more than 100 ft of total RG-6 coax between antenna and DSWM30

For access to 101° satellite programming, connect the MAIN and AUX ports of the antenna to both LNB inputs labeled Sat 99°/101°

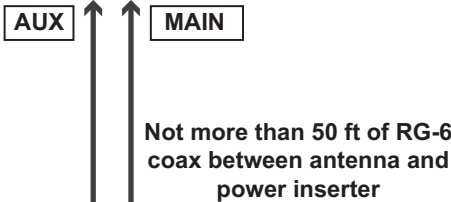

Not more than 50 ft of RG-6 coax between antenna and power inserter

**CONNECT COAX TO PROPER INPUTS!**  
MAIN TO 18V  
AUX TO 13V

110 AC/DC Power Supply

**KING Power Inserter**

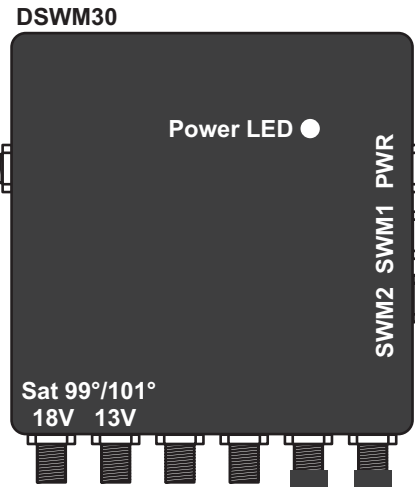

Unused SWM outputs: screw on dust cap (no center pin)

Not necessary if DSWM30 is used in dry conditions



**POWER INSERTER FOR INDOOR USE ONLY.**

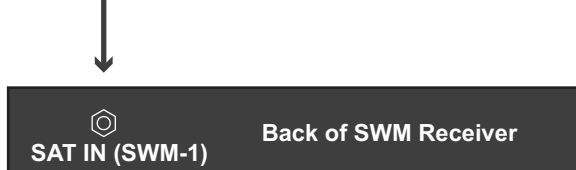

Receivers can be non-DVR or DVR receivers\*\*

\*\*If connecting to a DVR receiver, do not connect a coaxial cable to the Satellite 2 input. With SWM, only connect to the Satellite 1 port (labeled FTM or SWM)

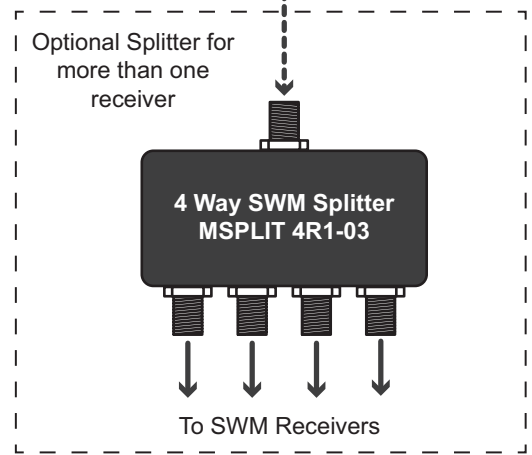

KING Antenna, KING Power Inserter (with power supply), 50' coax and short coax included. All other items sold separately.

# OPERATION

## RECEIVER CONFIGURATION

**Make sure your TV is on the correct input from your receiver.**

If your receiver screen does not appear on your TV, check TV input by pressing Source/Input button located on your TV or TV's remote.

**Configure your receiver as follows:**

**Switch Type:** Multi-switch

**Dish Type:** 3-LNB (18"x20") or 18x20" Triple-sat LNB

Make this one-time setting in the receiver's satellite setup menu.

## ANTENNA CONFIGURATION

DIRECTV uses mode 1. The KING One Pro comes factory preset for mode 1. If your antenna is new, you will not need to configure it.



**IF YOUR ANTENNA IS NEW, SKIP THIS STEP AND GO TO PAGE 10.**

MODE	SERVICE	SATELLITES	
1	DIRECTV	101, 119	DIRECTV subscribers
	DISH	61.5, 110, 119, 129	DISH subscribers with Wally, VIP211z, 211k, 211 or 411 receivers
2	DISH	110, 119, 129	DISH subscribers with receivers not listed in MODE 1
3	Bell TV	82, 91	Bell TV subscribers
4	DISH	61.5, 110, 119	DISH subscribers with receivers not listed in MODE 1



**IF YOUR ANTENNA IS NEW, SKIP THIS STEP AND GO TO PAGE 10.**

Make sure the LED is flashing orange (ready to scan)

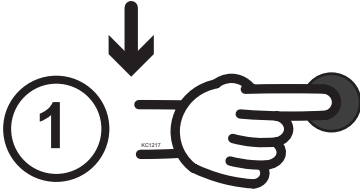

To enter Configuration Mode, press and hold (~3 sec) the power inserter button until one of the options below appears



Press and release as needed to choose Mode 1

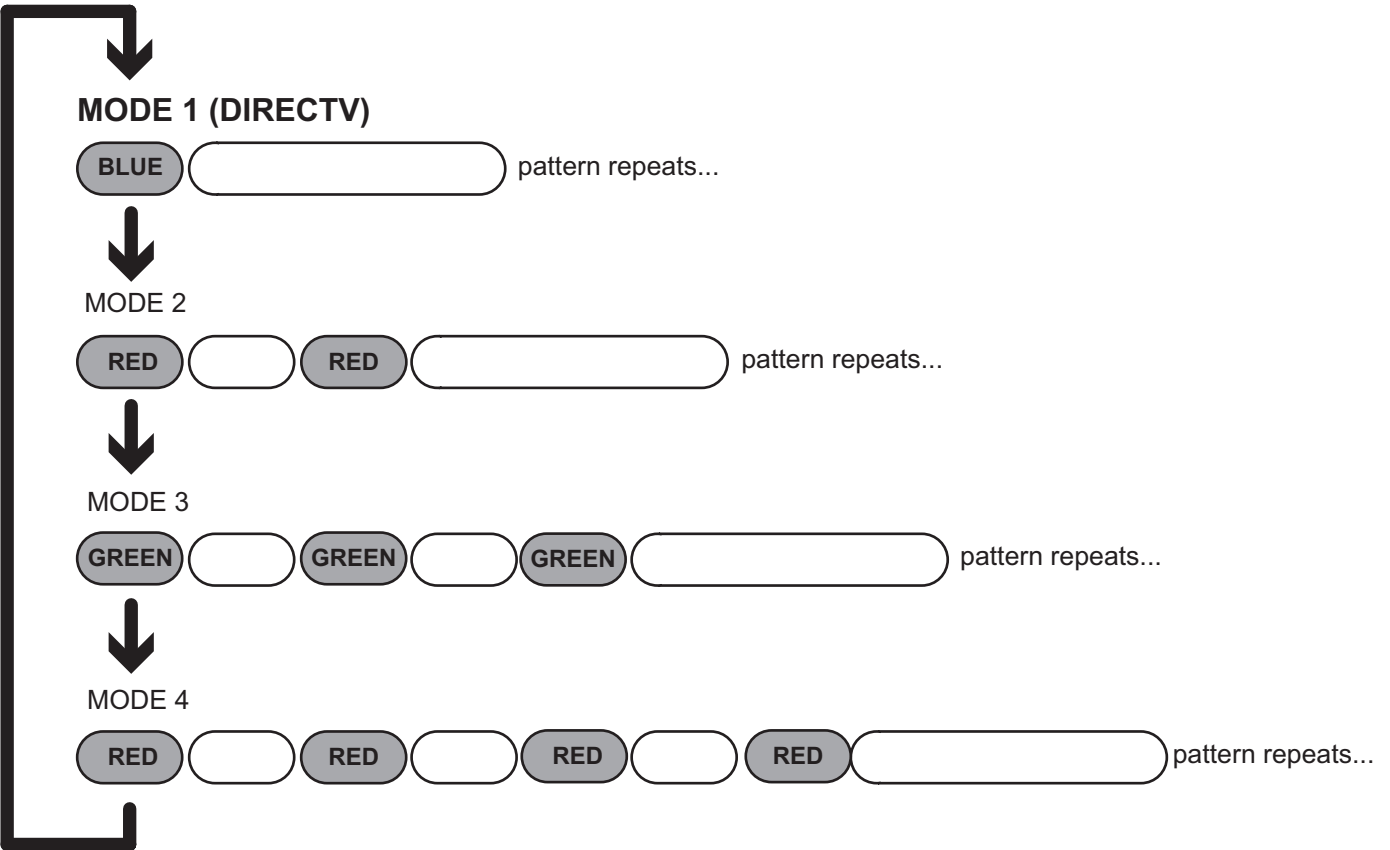

Press and hold (~3 sec) until LED flashes orange (ready to scan)



**Go to next page to start a scan.**

## SCAN FOR SATELLITES

Make sure the LED is flashing orange.



Press and release the power inserter button to start a scan



Antenna is scanning (flashing green)

SOLID GREEN

Both satellites found **Watch TV. Enjoy!**

**If one or both satellites were not found, you will get one of the flash patterns shown on the opposite page.**

Many times lack of satellite acquisition is due to obstructions. Try moving the antenna to have a better view of the southern sky, press the button once to turn the LED yellow, and a second time to start a new scan.

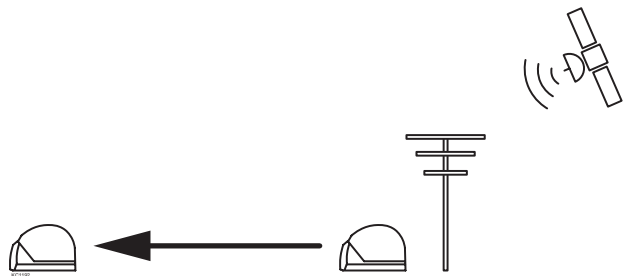

**NOTE:** If no satellites are found, you will have to start a new scan.

If only one satellite is found, you can press the button to turn the LED yellow and watch TV with limited channels.

If you get a different color and/or flash pattern on the LED than steady green or one of the patterns shown on the next page, the LED is flashing an error code. Call KING Customer Service for an explanation of the problem.

(952) 345-8147

# SATELLITES NOT FOUND

## MODE 1 (DIRECTV)

101 not found



119 not found

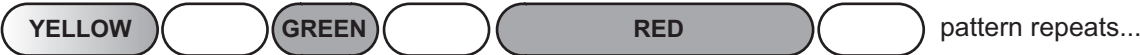

101 & 119 not found



# TROUBLESHOOTING

Symptom	Possible Cause	Troubleshooting
Antenna unit does not scan for satellites.	No power to antenna unit.	Make sure antenna unit is connected to power inserter.  Make sure power supply is plugged in and connected to power inserter.
Antenna unit scans but no picture on TV.	Improper connections made.	Make sure antenna unit is connected to power inserter, and power inserter is plugged in.  Make sure powered receiver is connected to TV and the power inserter.
Antenna unit scans but does not find satellite.	Line of sight obstruction.	Move antenna unit to have a clear view of the southern sky. Start a new scan.
Picture on TV goes in and out.	Temporary obstruction of signal.	Heavy rain or snow may cause loss of signal. Reception will improve as weather clears.  Make sure nothing is temporarily blocking view to the southern sky (like tree branches blowing in the wind).

If you connect or install the antenna unit using any of the vehicle's internal wiring/coax, and the antenna unit does not work properly, it could be the vehicle's wiring/coax. Connect a known good coax directly from the antenna unit to the power inserter and see if the problem goes away. If it does, the vehicle's wiring/coax is at fault. KING is not responsible for faulty vehicle wiring/coax.

# ACCESSORIES (Sold separately - see the satellite antenna accessories page at [kingconnect.com](http://kingconnect.com))

## MB700 Quick Release Roof-Mount Kit

Allows you to easily use your KING One Pro as either a roof-mounted or portable antenna.

KING Antenna not included.

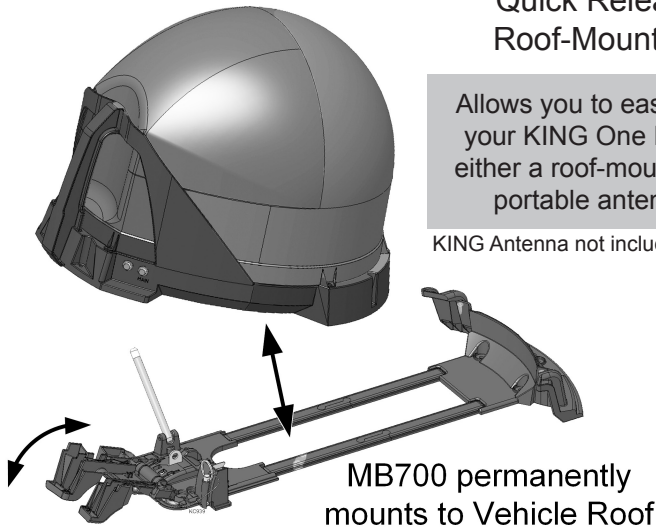

MB700 permanently mounts to Vehicle Roof

## MB500 Mounting Bracket

Includes (2)  
Hanger Brackets

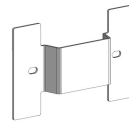

Allows hanging of antenna unit on vehicle window or included hanger bracket.

For stationary use only.  
Vehicle must not be in motion while antenna unit is on window or hanger bracket.

KING Antenna not included.

## CB1000 Carry Bag

KING One Pro fits securely inside. Features include zippered cover, foam padding, carry handles and pockets for cables, receiver and remote.

KING Antenna not included.



## TR1000 Tripod Mount

Allows you to position your KING One Pro almost anywhere for best line of sight to satellite. Keeps antenna off the ground away from moisture.

KING Antenna not included.



## MB160 Mounting Bracket

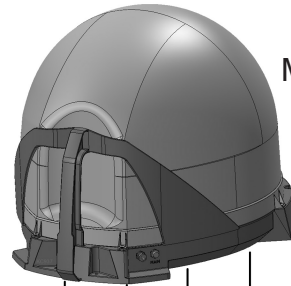

MB160 Mounts to  
Back of Vehicle

The KING One Pro is not compatible with the MB100 Mounting Bracket. Use of the MB100 will void warranty.

The use of any unauthorized mounting bracket will void warranty.

KING Antenna not included.

# LIMITED WARRANTY

KING One Pro Satellite Antennas are thoroughly inspected and tested before leaving the factory, and are covered by the following limited warranty from the date of original purchase:

- Two-year parts warranty: The customer is not responsible for the cost of replacement parts if the original part is determined to be defective under the terms of the warranty. The customer is responsible for the cost of replacement parts after two years.
- One-year labor warranty: The customer is not responsible for labor costs to repair unit if labor is performed within the labor warranty period. The customer is responsible for all labor costs after one year.

Only KING and certified dealers may perform warranty evaluations and repairs. Depending upon the problem, KING may authorize a dealer to perform the necessary repairs. Any warranty labor outside of that performed at the factory is not covered unless 1) the product has been installed by an authorized dealer/installer or OEM manufacturer and 2) the dealer/installer receives prior authorization to perform the repair.

A certified dealer must not perform any repair without first contacting KING for a Service Order Number. KING will advise the dealer on how to proceed with any repairs.

Should any trouble develop during the warranty period, contact KING at (952) 345-8147. You must contact KING before the warranty period expires. The customer must supply proof of purchase (such as a dated sales receipt) when requesting warranty service. If the customer cannot supply proof of purchase, warranty period shall start 30 days after date of manufacture.

If it is determined that the unit needs to be returned to KING, customer must return COMPLETE product, freight prepaid, to:

**KING, 11200 Hampshire Avenue South, Bloomington, MN 55438-2453.**

If inspection shows the trouble is caused by defective workmanship or material, KING will repair (or at its option, replace) without charge.

When returning product, KING will supply an RMA number (Return Merchandise Authorization). This number must be clearly written on the box. Failure to clearly write RMA number on box may result in delays in processing claim. Along with product, customer should include in the box: his/her name, address, daytime phone number, proof of purchase and description of the problem.

This warranty does not cover installation and external wiring, or remanufactured units. This warranty does not cover damage caused by the use of an accessory other than a KING accessory designed for the product. This warranty is not transferable from the original owner.

Due to the expanding and changing TV market, KING cannot be held responsible for changes made to satellite services. Software updates to address such issues are not covered under warranty.

This warranty also does not apply where:

- The product has been abused, misused, improperly installed or improperly maintained.
- The product has been used with an accessory other than a KING accessory designed for the product.
- Repairs have been made or attempted by others that are not certified by KING to do such repairs.
- Repairs are required because of normal wear and tear.
- Alterations have been made to the product.
- The product or any associated component has been opened without authorization or disassembled to any degree.
- Damage has been caused by power washing.
- Circumstances beyond the control of KING cause the product to no longer operate correctly.
- Customer is not the original owner.

In no event shall KING be liable for any indirect, incidental, or consequential damages from the sale or use of the product. This disclaimer applies both during and after the term of this warranty. KING disclaims liability for any implied warranties, including implied warranties of "merchantability" and "fitness for a specific purpose," after the term of this warranty.

This warranty gives you specific legal rights, and you may also have other rights, which vary from state to state. Some states do not allow the exclusion or limitation of incidental or consequential damages, so the above limitation or exclusion may not apply to you. Some states do not allow limitations on how long an implied warranty lasts, so the above limitation may not apply to you.

# FCC GUIDELINES

This equipment has been tested and found to comply with the limits for a Class B digital device, pursuant to part 15 of the FCC Rules. These limits are designed to provide reasonable protection against harmful interference in a residential installation. This equipment generates, uses and can radiate radio frequency energy and, if not installed and used in accordance with the instructions, may cause harmful interference to radio communications. However, there is no guarantee that interference will not incur in a particular installation. If this equipment does cause harmful interference to radio or television reception, which can be determined by turning the equipment off and on, the user is encouraged to try to correct the interference by one or more of the following measures:

- Reorient or relocate the receiving antenna.
- Increase the separation between the equipment and the receiver.
- Connect the equipment into an outlet on a circuit different from that to which the receiver is connected.
- Consult the dealer or an experienced radio/TV technician for help.

## NOTES:



**Simply better, by design.™**



---

11200 Hampshire Avenue South, Bloomington, MN 55438  
PH 952.922.6889 || FAX 952.922.8424 || [kingconnect.com](http://kingconnect.com)

©2019 KING

23432 Rev A

All trademarks are the sole property of their respective owners.

# **KING** || ONE<sup>PRO</sup><sup>™</sup>

---

---

## **KOP4800 Owner's Manual**



**For use with DISH<sup>®</sup> satellite programming**

This manual is for use with DISH receivers *except* for the following:

**Wally<sup>®</sup> • ViP<sup>®</sup>211z • ViP211k • ViP 211 • 411**

If you have one of the receivers listed above, do not use this manual.  
See the KING One Pro owner's manual for these receivers at  
*[kingconnect.com/support](http://kingconnect.com/support).*



## IMPORTANT!

The satellite TV market is expanding and changing. The information in this manual was accurate at the time of printing. If your KING One Pro Satellite Antenna does not operate as outlined in this manual, please call KING® at (952) 345-8147 or visit our website at [kingconnect.com](http://kingconnect.com). KING is not responsible for changes outside of its control.

### PRODUCT REGISTRATION

To provide ongoing technical support and to better facilitate warranty processing, please register your product at [kingconnect.com/support](http://kingconnect.com/support).



## CONTENTS

INTRODUCTION .....	2-3
IMPORTANT SAFETY AND CARE INFORMATION .....	2
ABOUT SIGNAL LOSS .....	3
SECURITY .....	3
SETUP .....	4
CONTENTS .....	4
APPLY RUBBER FEET TO ANTENNA UNIT .....	4
CONNECTIONS .....	5
OPERATIONS .....	6-13
ANTENNA CONFIGURATION .....	6-7
SCAN FOR SATELLITES .....	8-9
CHECK SWITCH TEST .....	10-11
SECOND RECEIVER OPERATION .....	12-13
TROUBLESHOOTING .....	14
ACCESSORIES .....	15
LIMITED WARRANTY .....	16
FCC GUIDELINES .....	16

# INTRODUCTION

**Thank you for choosing the premium KING One Pro Portable HDTV System!**

You are about to experience the excitement of satellite television programming and the convenience of the KING One Pro portable antenna, which delivers the very best HD picture and sound quality wherever you go.

## IMPORTANT SAFETY AND CARE INFORMATION

1. Keep the Quick Reference Guide and Installation Guide that came with your KING One Pro in a safe place for future reference. You may also print this on-line manual and keep it for future reference as well.
2. Follow all instructions and warnings. Set up and operate the KING One Pro in accordance with the instructions.
3. To avoid risk of electric shock, unplug your receiver before connecting/disconnecting the KING One Pro in damp or wet conditions.
4. Tighten all of the coax cable connections only by hand. If you use a wrench, you may over-tighten the connections and damage your equipment.
5. Always handle the KING One Pro carefully. Do not drop the KING One Pro. Avoid excessive shock or vibration to the KING One Pro.
6. Use caution when carrying the KING One Pro. Always carry the KING One Pro by the handle.
7. Do not remove the cover of the KING One Pro without authorization. Doing so will void the limited warranty.
8. Do not stack the KING One Pro on top of or below other electronic devices as this can cause heat build-up or block the satellite signal from reaching the KING One Pro.
9. Do not operate or store near any indoor or outdoor heat source such as radiators, heat registers, stoves, barbecues, campfires, or other items that produce heat.
6. Servicing may be required if the unit has been dropped or damaged in any way or if the unit does not operate normally. Call KING Customer Service at (952) 345-8147.
10. Do not power wash the KING One Pro.
11. Do not submerge the KING One Pro or place in standing water.
12. Keep the enclosure clean from dirt, bugs, and other debris by hand washing with mild soap and water.
13. Do not coat or paint the KING One Pro with any substance.

The KING One Pro has been designed to be maintenance and trouble free. If not using the KING One Pro for long periods of time, it is recommended that you set up the system on a quarterly basis (every three months) to keep all moving parts of the KING One Pro in good working order.

If you have any comments or questions, please contact KING Customer Service at (952) 345-8147, or by email at [help@kingconnect.com](mailto:help@kingconnect.com).

**QUESTIONS? (952) 345-8147**

## ABOUT SIGNAL LOSS

### OBSTRUCTIONS

The KING One Pro requires an unobstructed view of the southern sky for the best signal reception.

Be sure to place the KING One Pro in a location free from obstructions such as people, trees, buildings, vehicles, etc. This will allow for the strongest signal and will help prevent any interruption to your programming. Point the handle approximately north to speed up scan time.

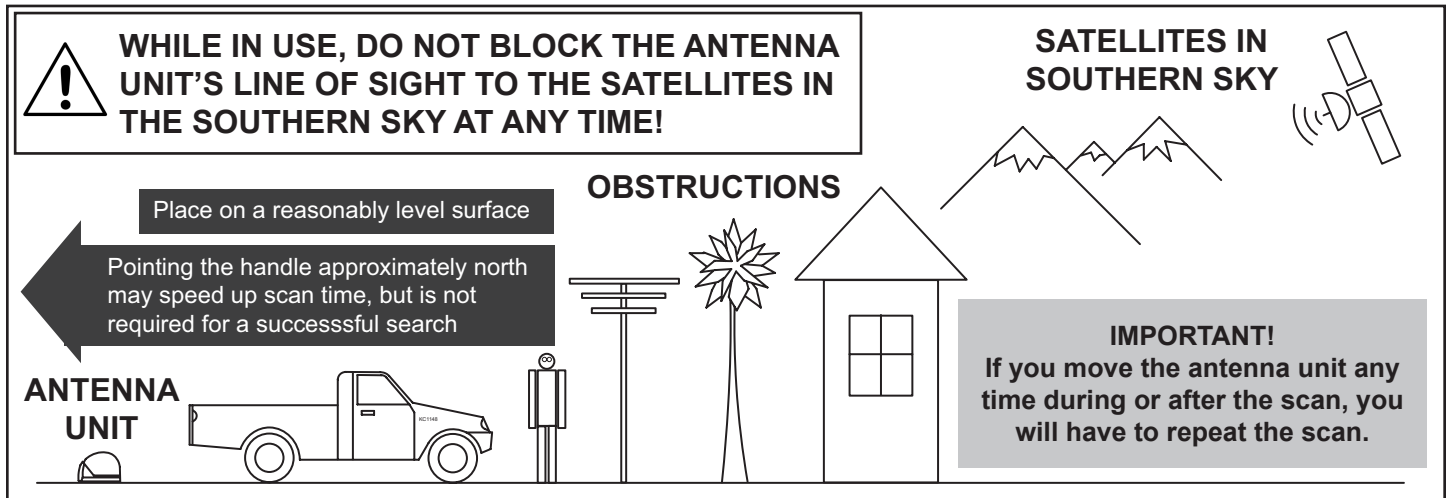

### RAIN AND SNOW FADE

Though rare, heavy rain, snow, or dense cloud cover can reduce the satellite signal, which may interrupt your programming. Your programming should return as conditions improve.

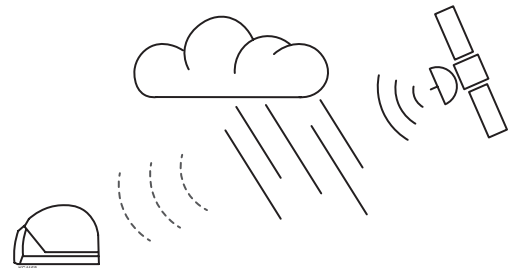

## SECURITY

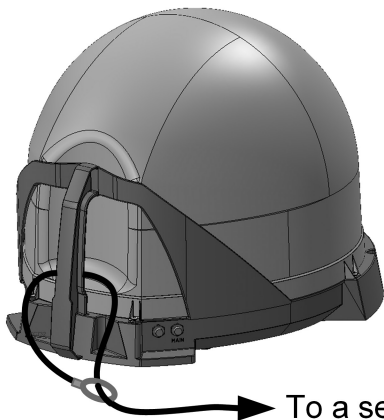

The KING Antenna can be secured to an object by looping a cable thru the handle.

Cable sold separately.

# SETUP

## CONTENTS

Antenna Unit

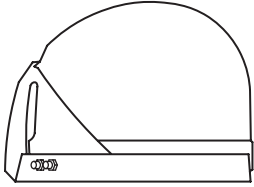

Power Inserter with Power Supply

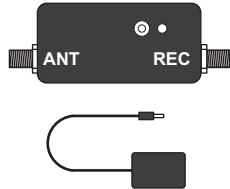

You will also need (sold separately):

DISH Programming Subscription



DISH Receiver

Cable(s)

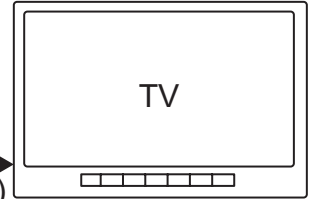

For the most up-to-date receiver compatibility information, go to [kingconnect.com/support](http://kingconnect.com/support)



Installation Guide

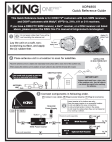

Quick Reference Guide



Registration Card

(3) Rubber Feet



50' RG-6 Coax Cable



Short Coax Cable

## APPLY RUBBER FEET TO ANTENNA UNIT

### IMPORTANT!

Do not apply rubber feet if roof-mounting the antenna unit. See the Installation Guide included in the box.

Do not apply here.

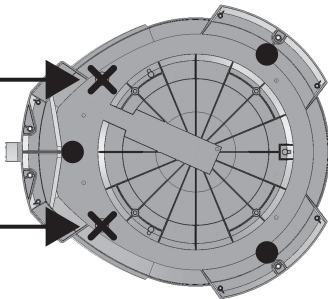

Apply (3) rubber feet

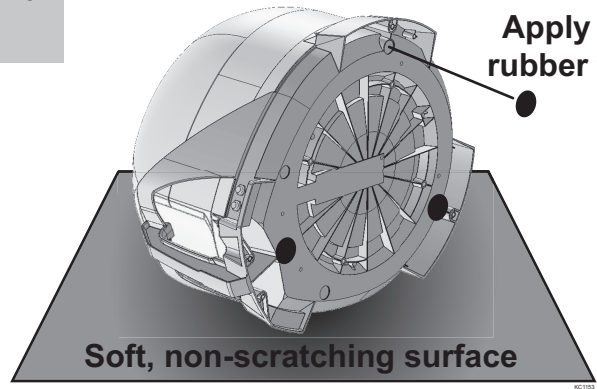

## CONNECTIONS

Connect components in following order.

**A** Connect coax cables. **B** Plug in power inserter. **C** Plug in receiver(s).

**Power inserter is for indoor use only.**

Place the power inserter in an accessible location.



Do not over-tighten the coax connections.

Do not put sharp bends or kinks in the cables.

Do not route the cables where they can be tripped on or run over by a vehicle.

**NOTE:** If your main receiver has two SAT IN ports: AUX coax may be connected to second SAT IN port for dual tuner usage.

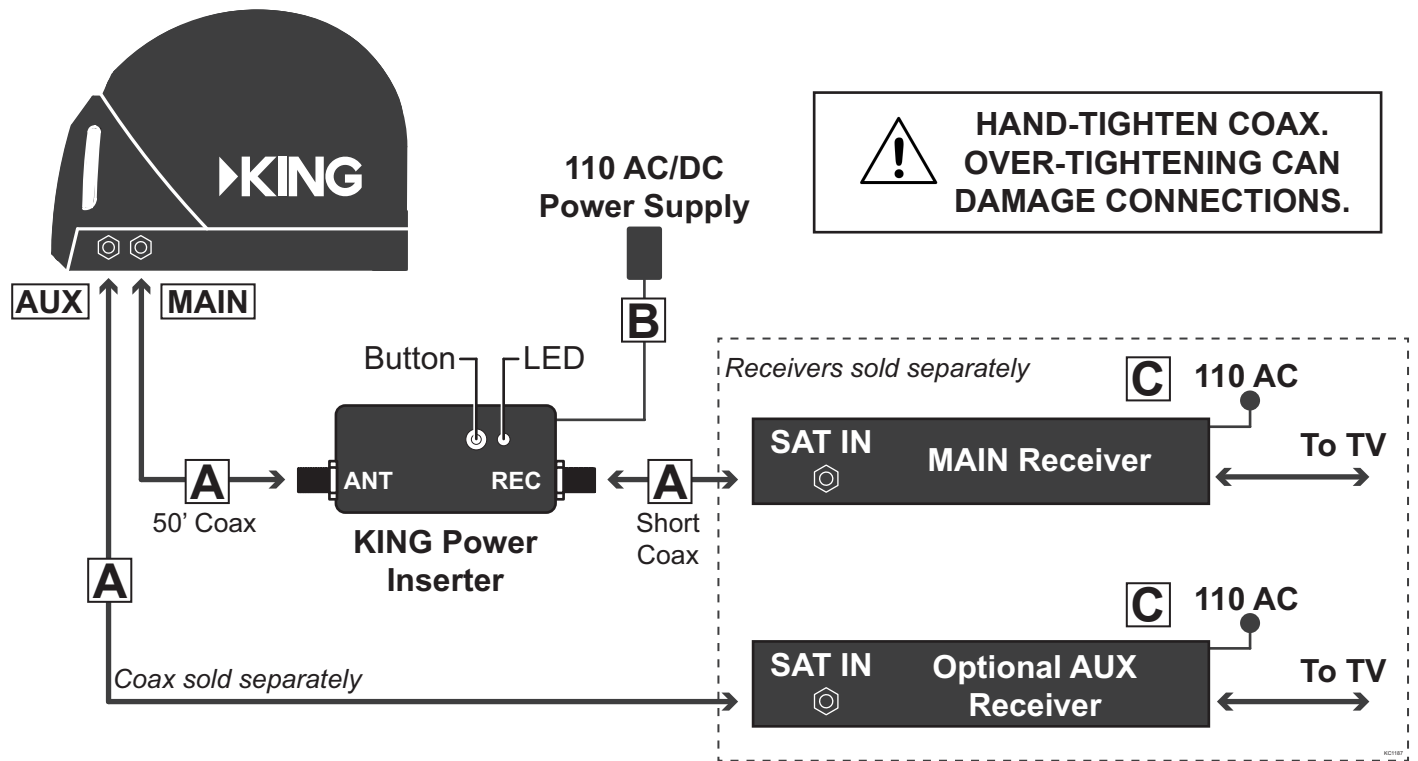

**AVOID SHARP BENDS WHEN ROUTING COAX!**

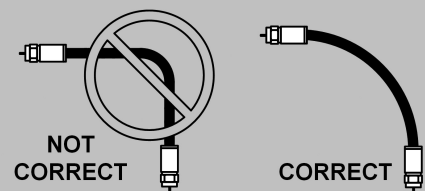

After connecting and plugging in all components, wait for the power inserter LED to start flashing orange (about 10 seconds).

Go to the next page.

# OPERATION

## ANTENNA CONFIGURATION

The KING One Pro comes factory preset for mode 1. You will need to choose either mode 2 (Western Arc) or mode 4 (Hybrid Arc) based on where you are in the country, and then configure the antenna as shown on the next page.

This is a one-time procedure unless you travel between the two modes and wish to reconfigure the antenna for better satellite acquisition (see additional notes in map box below).

MODE	SERVICE	SATELLITES	
1	DIRECTV®	101, 119	DIRECTV subscribers
	DISH	61.5, 110, 119, 129	DISH subscribers with Wally, ViP211z, 211k, 211 or 411 receivers
2	DISH	110, 119, 129	<b>DISH subscribers with receivers not listed in MODE 1</b>
3	Bell TV™	82, 91	Bell TV subscribers
4	DISH	61.5, 110, 119	<b>DISH subscribers with receivers not listed in MODE 1</b> NOTE: This is an alternative mode to mode 2. Signal strength from the 129 may be reduced in the far northeastern US. Use this mode if you cannot lock onto the 129 when in this area.

**MODE 2 Western Arc**

**MODE 4 Hybrid Arc**

Reception from the 129 may be difficult in this area. Choose Mode 4 for best signal reception.

Mode 2 will work for most of the country.

The antenna unit may have trouble locking onto the 129 when in the northeastern United States (you can use the Dish Diagnostics Screen after a scan to check this).

If the antenna unit does not lock onto the 129, choose mode 4. Any programming from the 129 will not be available when using mode 4.

You can switch between the two modes as necessary when traveling between the coverage areas shown.

129      119      110      61.5

Make sure the LED is flashing orange (ready to scan)



1



To enter Configuration Mode, press and hold (~3 sec) the power inserter button until one of the options below appears

2



Press and release as needed to choose either Mode 2 or Mode 4

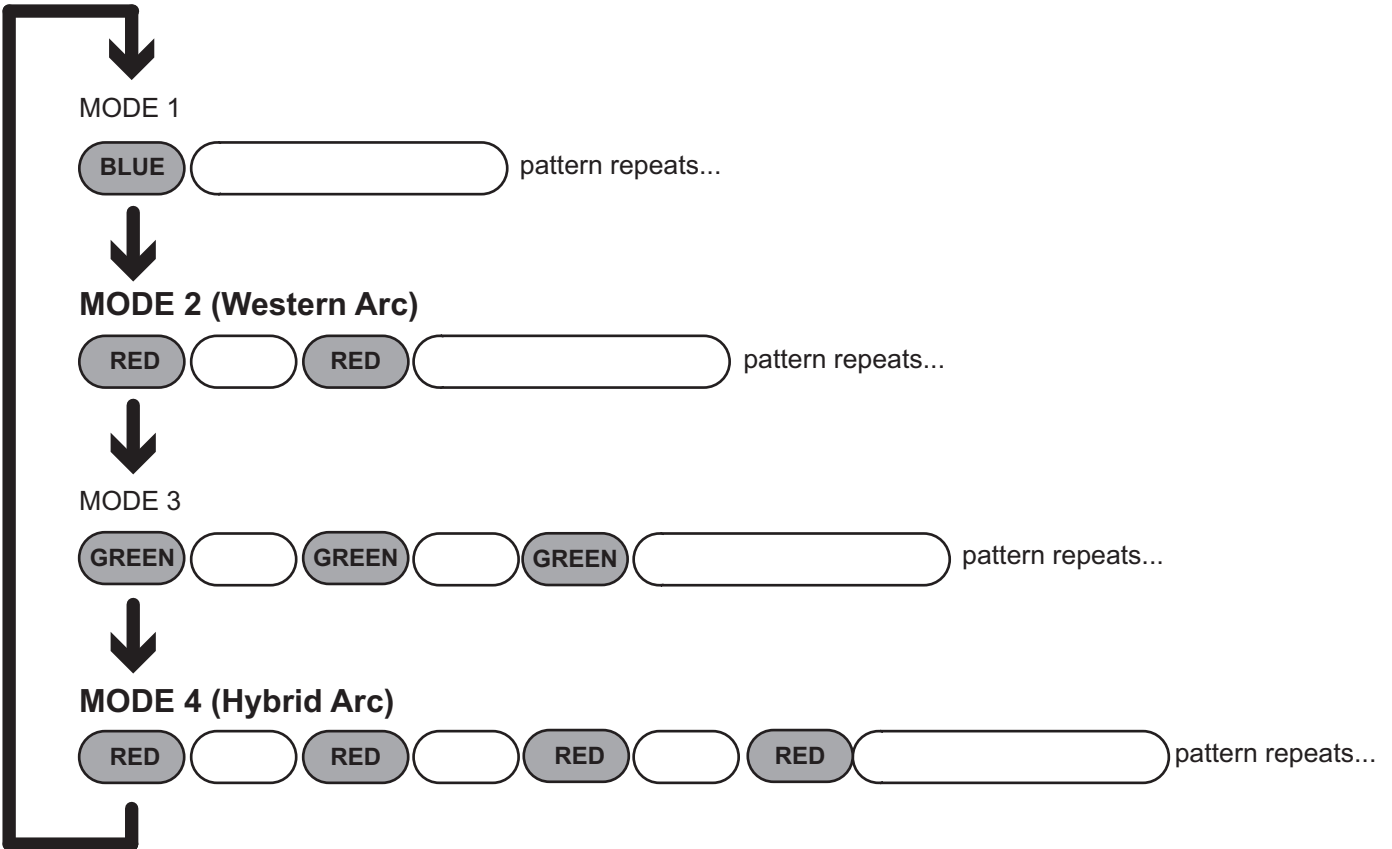

3



Press and hold (~3 sec) until LED flashes orange (ready to scan)



Go to next page to start a scan.

## SCAN FOR SATELLITES

4



Press and release to start a scan



Antenna is scanning (flashing green)

SOLID GREEN

All 3 satellites found

**If all 3 satellites were found, go to page 10 and run the check switch.**

**If less than 3 satellites were found, you will get one of the flash patterns shown on the opposite page.**

If not all satellites were found, you can still run the check switch on page 10, but you will have fewer available channels when it is complete.

Many times lack of satellite acquisition is due to obstructions. Try moving the antenna to have a better view of the southern sky, press the button once to turn the LED yellow, and a second time to start a new scan.

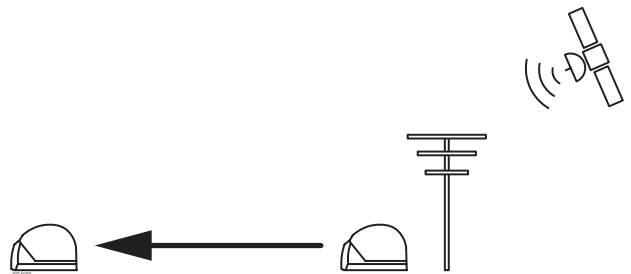

**NOTE:** If no satellites are found, you will have to start a new scan.

If you get a different color and/or flash pattern on the LED than steady green or one of the patterns shown on the next page, the LED is flashing an error code. Call KING Customer Service for an explanation of the problem.

(952) 345-8147

# SATELLITES NOT FOUND

## MODE 2 (Western Arc) and MODE 4 (Hybrid Arc)

No satellites found



### MODE 2 (Western Arc)

110 not found



119 not found



129 not found



110 & 119 not found



110 & 129 not found



119 & 129 not found



### MODE 4 (Hybrid Arc)

61.5 not found



110 not found



119 not found



61.5 & 110 not found



61.5 & 119 not found



110 & 119 not found



## CHECK SWITCH TEST

**5** Run a check switch test. **This is a one-time procedure unless noted in gray box below.**

**NOTE:** The SW64 switch is a receiver software configuration that is loaded into the receiver after successfully running a check switch test with the dish locked on and configured for the appropriate service.

**Step 5 is a one-time procedure that will not need to be repeated after successful installation, unless:**

- a) check switch test is run again while the receiver is connected to a home dish system.
- b) check switch test is run when the receiver is not connected.
- c) you travel outside the coverage area of either arc and switch to the other.
- d) you are parked in an area where the selected satellites are blocked, but are able to select alternate satellites and get signal.

5.1 On the receiver remote, press **MENU, 6, 1, 1** to go to the Point Dish screen.

5.2 Highlight "Check Switch."

Press **SELECT** on your remote.

**NOTE:** Some receivers may prompt you to select "Check Switch" a second time to initiate the test.

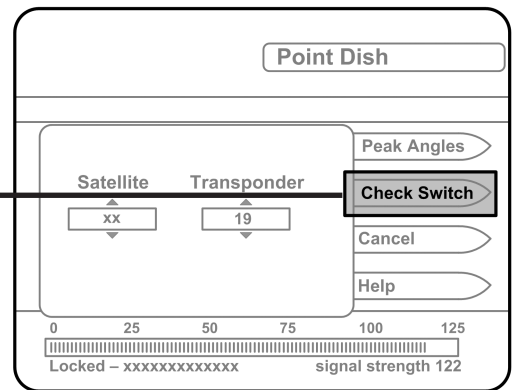

Screen graphics may vary.

5.3 Make sure "SuperDISH" and "Alternate" boxes are **NOT** selected.

**NOTE:** Not all receivers will display a screen with options that include "SuperDISH" and "Alternate" boxes.

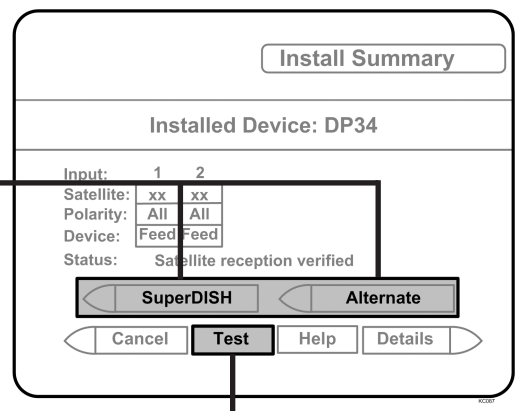

5.4 Highlight "Test."

Press **SELECT** on your remote.

The receiver will perform a check switch test. This process can take a little while so PLEASE BE PATIENT.

5.5 When test is complete, a screen similar to one below should appear.

**Because receivers are always changing, screen graphics may vary.**

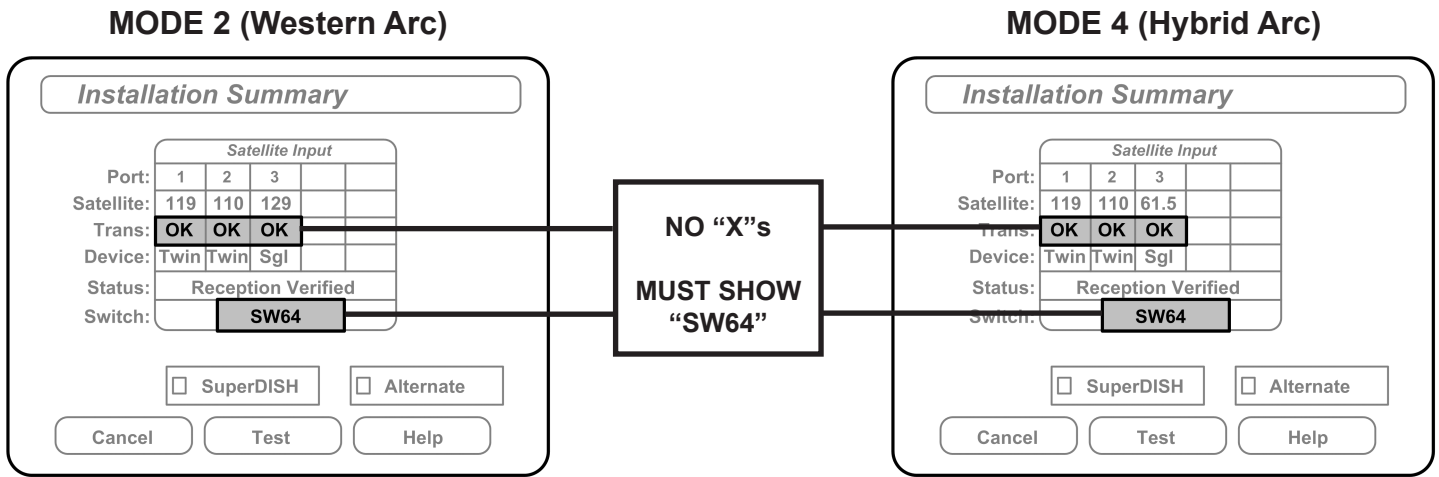

If the indicated results are not obtained, go back to Step 5.1 and run test again. Contact KING if the check switch fails to load after 4 attempts.

5.6 When the installation summary shows the successful check switch test results, save the settings, exit to the main menu screen and wait for programming to download.

**NOTE:** Verify that your saved settings show your desired satellite trio: 61.5, 110, 119 (Hybrid Arc) or 110, 119, 129 (Western Arc).

5.7 When programming has downloaded, select your desired channel. **Enjoy!**

#### OPERATING NOTES:

**For standard operation, make all connections and start a scan (step 4).  
Wait for programming to download, select your desired channel and watch TV.**

If you move the vehicle, you will have to reacquire the satellites by repeating the scan process.

Your local channels may not be available when traveling outside your home area.

## SECOND RECEIVER OPERATION

### INITIAL SETUP FOR SECOND RECEIVER

1. With the antenna locked on the satellite and the second receiver connected to the antenna unit's AUX port coax, use your DISH remote control and press **MENU, 6, 1, 1** to display the *Point Dish* screen.

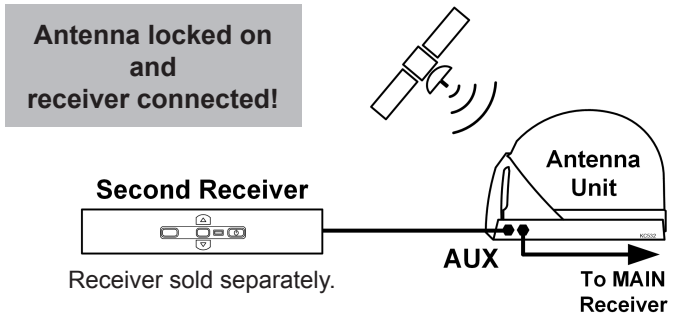

2. Use the arrow buttons on the remote to highlight "Check Switch."

Press **SELECT** on your remote.

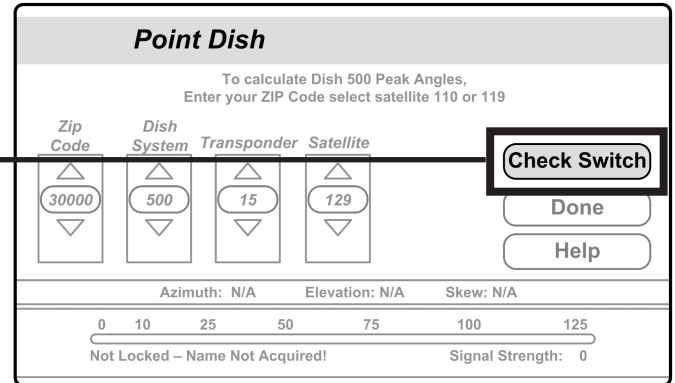

3. Verify "SuperDISH" and "Alternate" are not selected.

Verify "Test" is highlighted.

Press **SELECT** on your remote.

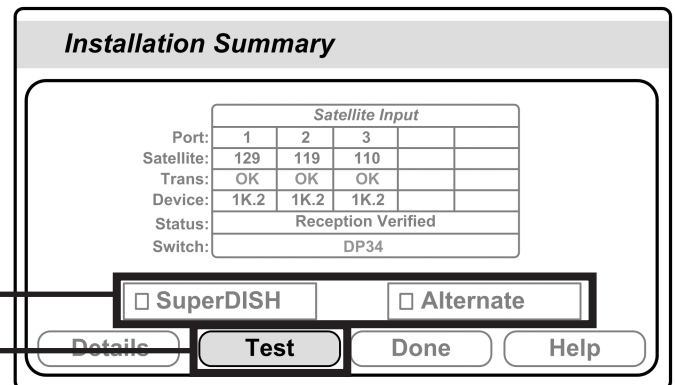

4. When test is complete, highlight "Save."

Press **SELECT** on your remote.

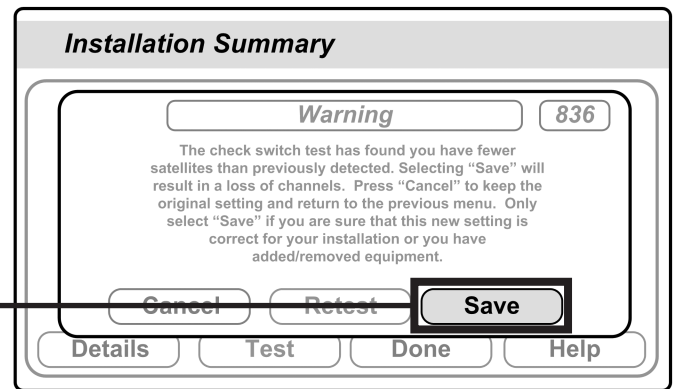

**See the next page for downloading programming to the second receiver.**

## DOWNLOADING PROGRAMMING TO THE SECOND RECEIVER

1. After completing the steps on the previous page, reset the second receiver by pressing the POWER button on the front panel for 10 seconds. The TV picture will go away and should reappear within two minutes.

The receiver will then download the program guide to show only the channels available on the current satellite as determined by the channel selected on the main receiver. Downloading the new program guide can take up to five minutes to complete.

The channels available on the second receiver are determined by the channel/satellite selected on the main receiver. For example, if you select a channel on the main receiver that is broadcast from the 119 satellite, then the second receiver will be able to view any channel broadcast from the 119 satellite.

If you switch channels on the main receiver to one that is broadcast from a different satellite, (i.e. your channel was broadcast from satellite 119 but your new channel is broadcast from the 110 or 129), the antenna will automatically switch to the new satellite and programming will be lost on the second receiver until you either:

- Select a channel on the main receiver that is broadcast from the previous satellite (satellite 119 in this example).
- (or)
- Reset the second receiver to download the program guide for the newly selected satellite (satellite 110 or 129 in this example).

If you choose a channel on the main TV that causes the antenna to switch satellites, you may have to run a check switch on the second receiver.

# TROUBLESHOOTING

Symptom	Possible Cause	Troubleshooting
Antenna unit does not scan for satellites.	No power to antenna unit.	Make sure antenna unit is connected to power inserter.  Make sure power supply is plugged in and connected to power inserter.
Antenna unit scans but no picture on TV.	Improper connections made.	Make sure antenna unit is connected to power inserter, and power inserter is plugged in.  Make sure powered receiver is connected to TV and the power inserter.
Antenna unit scans but does not find satellite.	Line of sight obstruction.	Move antenna unit to have a clear view of the southern sky. Start a new scan.
Picture on TV goes in and out.	Temporary obstruction of signal.	Heavy rain or snow may cause loss of signal. Reception will improve as weather clears.  Make sure nothing is temporarily blocking view to the southern sky (like tree branches blowing in the wind).

If you connect or install the antenna unit using any of the vehicle's internal wiring/coax, and the antenna unit does not work properly, it could be the vehicle's wiring/coax. Connect a known good coax directly from the antenna unit to the power inserter and see if the problem goes away. If it does, the vehicle's wiring/coax is at fault. KING is not responsible for faulty vehicle wiring/coax.

# ACCESSORIES (Sold separately - see the satellite antenna accessories page at [kingconnect.com](http://kingconnect.com))

## MB700 Quick Release Roof-Mount Kit

Allows you to easily use your KING One Pro as either a roof-mounted or portable antenna.

KING Antenna not included.

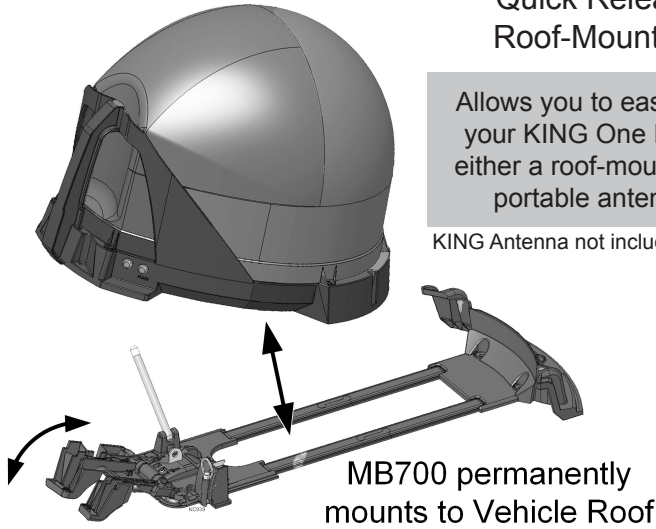

## MB500 Mounting Bracket

Includes (2)  
Hanger Brackets

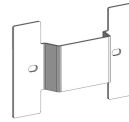

Allows hanging of antenna unit on vehicle window or included hanger bracket.

For stationary use only.  
Vehicle must not be in motion while antenna unit is on window or hanger bracket.

KING Antenna not included.

## CB1000 Carry Bag

KING One Pro fits securely inside. Features include zippered cover, foam padding, carry handles and pockets for cables, receiver and remote.

KING Antenna not included.



## TR1000 Tripod Mount

Allows you to position your KING One Pro almost anywhere for best line of sight to satellite. Keeps antenna off the ground away from moisture.

KING Antenna not included.



## MB160 Mounting Bracket

MB160 Mounts to  
Back of Vehicle

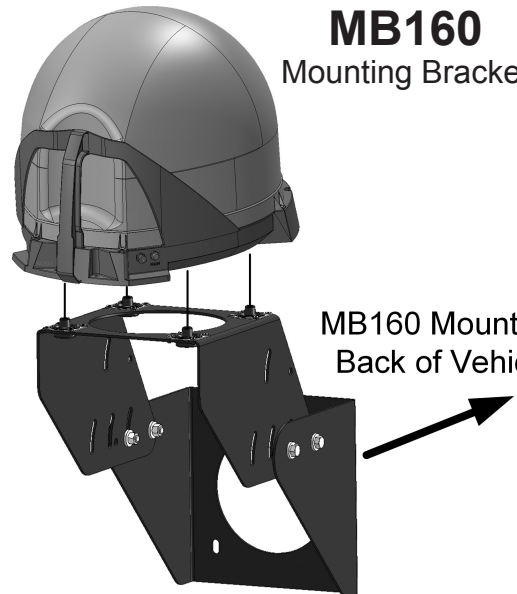

The KING One Pro is not compatible with the MB100 Mounting Bracket. Use of the MB100 will void warranty.

The use of any unauthorized mounting bracket will void warranty.

KING Antenna not included.

# LIMITED WARRANTY

KING One Pro Satellite Antennas are thoroughly inspected and tested before leaving the factory, and are covered by the following limited warranty from the date of original purchase:

- Two-year parts warranty: The customer is not responsible for the cost of replacement parts if the original part is determined to be defective under the terms of the warranty. The customer is responsible for the cost of replacement parts after two years.
- One-year labor warranty: The customer is not responsible for labor costs to repair unit if labor is performed within the labor warranty period. The customer is responsible for all labor costs after one year.

Only KING and certified dealers may perform warranty evaluations and repairs. Depending upon the problem, KING may authorize a dealer to perform the necessary repairs. Any warranty labor outside of that performed at the factory is not covered unless 1) the product has been installed by an authorized dealer/installer or OEM manufacturer and 2) the dealer/installer receives prior authorization to perform the repair.

A certified dealer must not perform any repair without first contacting KING for a Service Order Number. KING will advise the dealer on how to proceed with any repairs.

Should any trouble develop during the warranty period, contact KING at (952) 345-8147. You must contact KING before the warranty period expires. The customer must supply proof of purchase (such as a dated sales receipt) when requesting warranty service. If the customer cannot supply proof of purchase, warranty period shall start 30 days after date of manufacture.

If it is determined that the unit needs to be returned to KING, customer must return COMPLETE product, freight prepaid, to:

**KING, 11200 Hampshire Avenue South, Bloomington, MN 55438-2453.**

If inspection shows the trouble is caused by defective workmanship or material, KING will repair (or at its option, replace) without charge.

When returning product, KING will supply an RMA number (Return Merchandise Authorization). This number must be clearly written on the box. Failure to clearly write RMA number on box may result in delays in processing claim. Along with product, customer should include in the box: his/her name, address, daytime phone number, proof of purchase and description of the problem.

This warranty does not cover installation and external wiring, or remanufactured units. This warranty does not cover damage caused by the use of an accessory other than a KING accessory designed for the product. This warranty is not transferable from the original owner.

Due to the expanding and changing TV market, KING cannot be held responsible for changes made to satellite services. Software updates to address such issues are not covered under warranty.

This warranty also does not apply where:

- The product has been abused, misused, improperly installed or improperly maintained.
- The product has been used with an accessory other than a KING accessory designed for the product.
- Repairs have been made or attempted by others that are not certified by KING to do such repairs.
- Repairs are required because of normal wear and tear.
- Alterations have been made to the product.
- The product or any associated component has been opened without authorization or disassembled to any degree.
- Damage has been caused by power washing.
- Circumstances beyond the control of KING cause the product to no longer operate correctly.
- Customer is not the original owner.

In no event shall KING be liable for any indirect, incidental, or consequential damages from the sale or use of the product. This disclaimer applies both during and after the term of this warranty. KING disclaims liability for any implied warranties, including implied warranties of "merchantability" and "fitness for a specific purpose," after the term of this warranty.

This warranty gives you specific legal rights, and you may also have other rights, which vary from state to state. Some states do not allow the exclusion or limitation of incidental or consequential damages, so the above limitation or exclusion may not apply to you. Some states do not allow limitations on how long an implied warranty lasts, so the above limitation may not apply to you.

# FCC GUIDELINES

This equipment has been tested and found to comply with the limits for a Class B digital device, pursuant to part 15 of the FCC Rules. These limits are designed to provide reasonable protection against harmful interference in a residential installation. This equipment generates, uses and can radiate radio frequency energy and, if not installed and used in accordance with the instructions, may cause harmful interference to radio communications. However, there is no guarantee that interference will not occur in a particular installation. If this equipment does cause harmful interference to radio or television reception, which can be determined by turning the equipment off and on, the user is encouraged to try to correct the interference by one or more of the following measures:

- Reorient or relocate the receiving antenna.
- Increase the separation between the equipment and the receiver.
- Connect the equipment into an outlet on a circuit different from that to which the receiver is connected.
- Consult the dealer or an experienced radio/TV technician for help.



**Simply better, by design.™**



---

11200 Hampshire Avenue South, Bloomington, MN 55438  
PH 952.922.6889 || FAX 952.922.8424 || [kingconnect.com](http://kingconnect.com)

©2019 KING

23435 Rev A

All trademarks are the sole property of their respective owners.

# **KING** || **ONE<sup>PRO</sup>**<sup>™</sup>

## **KOP4800 Owner's Manual**

This manual contains detailed information on your KING One Pro.

To start using your KING One Pro right away,  
see the Quick Reference Guide.



## **DISH<sup>®</sup> & Wally<sup>®</sup> Receivers**

### **IMPORTANT!**

The KING One Pro works with DIRECTV<sup>®</sup>, DISH, and Bell<sup>™</sup> TV. This manual is for DISH subscribers with Wally receivers. Manuals for DISH (with other receivers), DIRECTV and Bell subscribers are available at [kingconnect.com](http://kingconnect.com). Use this manual only if you have a Wally receiver.



## IMPORTANT!

The satellite TV market is expanding and changing. The information in this manual was accurate at the time of printing. If your KING One Pro Satellite Antenna does not operate as outlined in this manual, please call KING® at (952) 345-8147 or visit our website at [kingconnect.com](http://kingconnect.com). KING is not responsible for changes outside of its control.

### PRODUCT REGISTRATION

To provide ongoing technical support and to better facilitate warranty processing, please register your product at [kingconnect.com/support](http://kingconnect.com/support).



INTRODUCTION .....	2-3
IMPORTANT SAFETY AND CARE INFORMATION .....	2
ABOUT SIGNAL LOSS .....	3
SECURITY .....	3
SETUP .....	4
CONTENTS .....	4
APPLY RUBBER FEET TO ANTENNA UNIT .....	4
CONNECTIONS .....	5
ANTENNA CONFIGURATION .....	6-7
OPERATION .....	8-18
NEW AND UNACTIVATED WALLY RECEIVER .....	8-13
STANDARD OPERATION .....	14-17
SECOND RECEIVER OPERATION .....	18
ACCESSORIES .....	19
TROUBLESHOOTING .....	20-23
LIMITED WARRANTY .....	24
FCC GUIDELINES .....	25

# INTRODUCTION

**Thank you for choosing the premium KING One Pro Portable HDTV System!**

You are about to experience the excitement of satellite television programming and the convenience of the KING One Pro portable antenna, which delivers the very best HD picture and sound quality wherever you go.

## IMPORTANT SAFETY AND CARE INFORMATION

1. Keep the Quick Reference Guide and Installation Guide that came with your KING One Pro in a safe place for future reference. You may also print this on-line manual and keep it for future reference as well.
2. Follow all instructions and warnings. Set up and operate the KING One Pro in accordance with the instructions.
3. To avoid risk of electric shock, unplug your receiver before connecting/disconnecting the KING One Pro in damp or wet conditions.
4. Tighten all of the coax cable connections only by hand. If you use a wrench, you may over-tighten the connections and damage your equipment.
5. Always handle the KING One Pro carefully. Do not drop the KING One Pro. Avoid excessive shock or vibration to the KING One Pro.
6. Use caution when carrying the KING One Pro. Always carry the KING One Pro by the handle.
7. Do not remove the cover of the KING One Pro without authorization. Doing so will void the limited warranty.
8. Do not stack the KING One Pro on top of or below other electronic devices as this can cause heat build-up or block the satellite signal from reaching the KING One Pro.
9. Do not operate or store near any indoor or outdoor heat source such as radiators, heat registers, stoves, barbecues, campfires, or other items that produce heat.
6. Servicing may be required if the unit has been dropped or damaged in any way or if the unit does not operate normally. Call KING Customer Service at (952) 345-8147.
10. Do not power wash the KING One Pro.
11. Do not submerge the KING One Pro or place in standing water.
12. Keep the enclosure clean from dirt, bugs, and other debris by hand washing with mild soap and water.
13. Do not coat or paint the KING One Pro with any substance.

The KING One Pro has been designed to be maintenance and trouble free. If not using the KING One Pro for long periods of time, it is recommended that you set up the system on a quarterly basis (every three months) to keep all moving parts of the KING One Pro in good working order.

If you have any comments or questions, please contact KING Customer Service at (952) 345-8147, or by email at [help@kingconnect.com](mailto:help@kingconnect.com).

**QUESTIONS? (952) 345-8147**

## ABOUT SIGNAL LOSS

### OBSTRUCTIONS

The KING One Pro requires an unobstructed view of the southern sky for the best signal reception.

Be sure to place the KING One Pro in a location free from obstructions such as people, trees, buildings, vehicles, etc. This will allow for the strongest signal and will help prevent any interruption to your programming. Point the handle approximately north to speed up scan time.

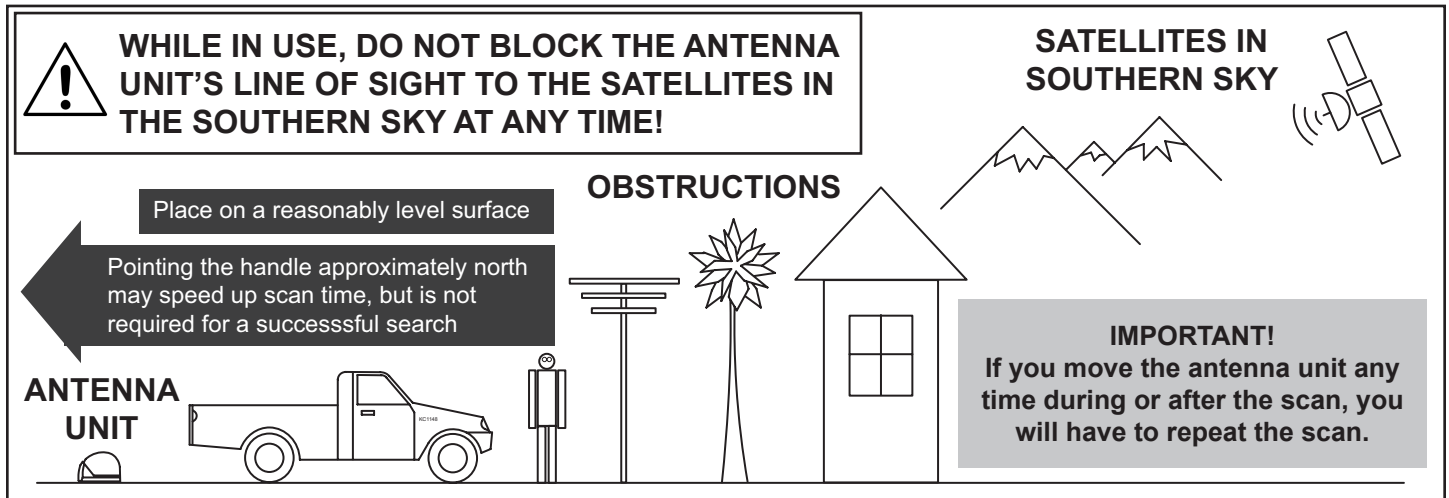

### RAIN AND SNOW FADE

Though rare, heavy rain, snow, or dense cloud cover can reduce the satellite signal, which may interrupt your programming. Your programming should return as conditions improve.

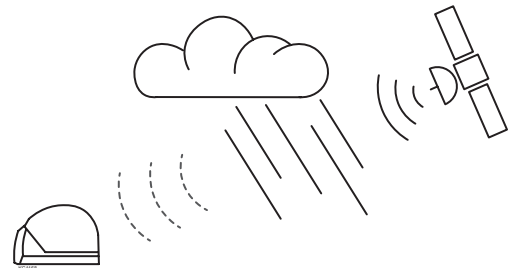

## SECURITY

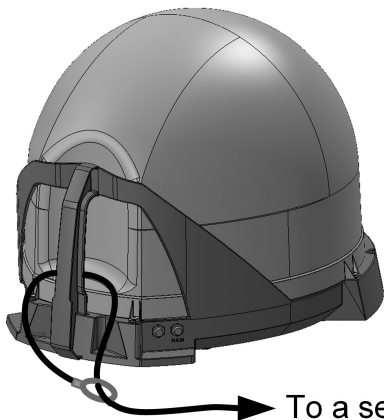

The KING Antenna can be secured to an object by looping a cable thru the handle.

To a secure object

Cable sold separately.

# SETUP

## CONTENTS

Antenna Unit

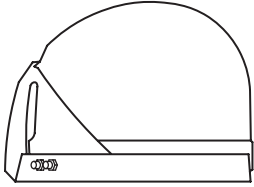

Power Inserter with Power Supply

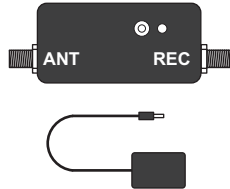

You will also need (sold separately):

DISH Programming Subscription



TV

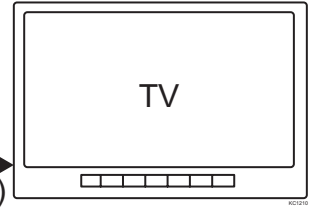

DISH Wally Receiver

Cable(s)



Installation Guide



Quick Reference Guide



Registration Card

(3) Rubber Feet



50' RG-6 Coax Cable



Short Coax Cable

## APPLY RUBBER FEET TO ANTENNA UNIT

### IMPORTANT!

Do not apply rubber feet if roof-mounting the antenna unit. See the Installation Guide included in the box.

Do not apply here.

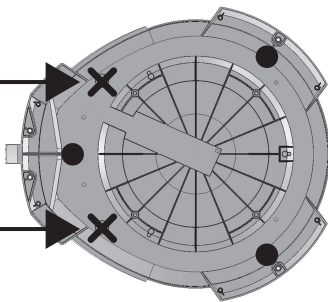

Apply (3) rubber feet

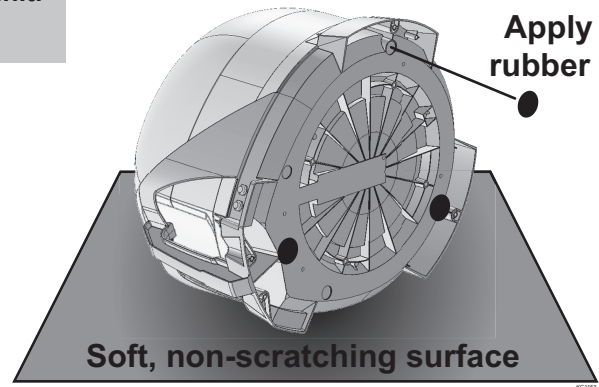

Soft, non-scratching surface

## CONNECTIONS

Connect components in following order.

- A** Connect coax cables. **B** Plug in power inserter. **C** Plug in receiver(s).

**Power inserter is for indoor use only.**

Place the power inserter in an accessible location.

Do not over-tighten the coax connections.

Do not put sharp bends or kinks in the cables.

Do not route the cables where they can be tripped on or run over by a vehicle.

**NOTE:** If your main receiver has two SAT IN ports: AUX coax may be connected to second SAT IN port for dual tuner usage.

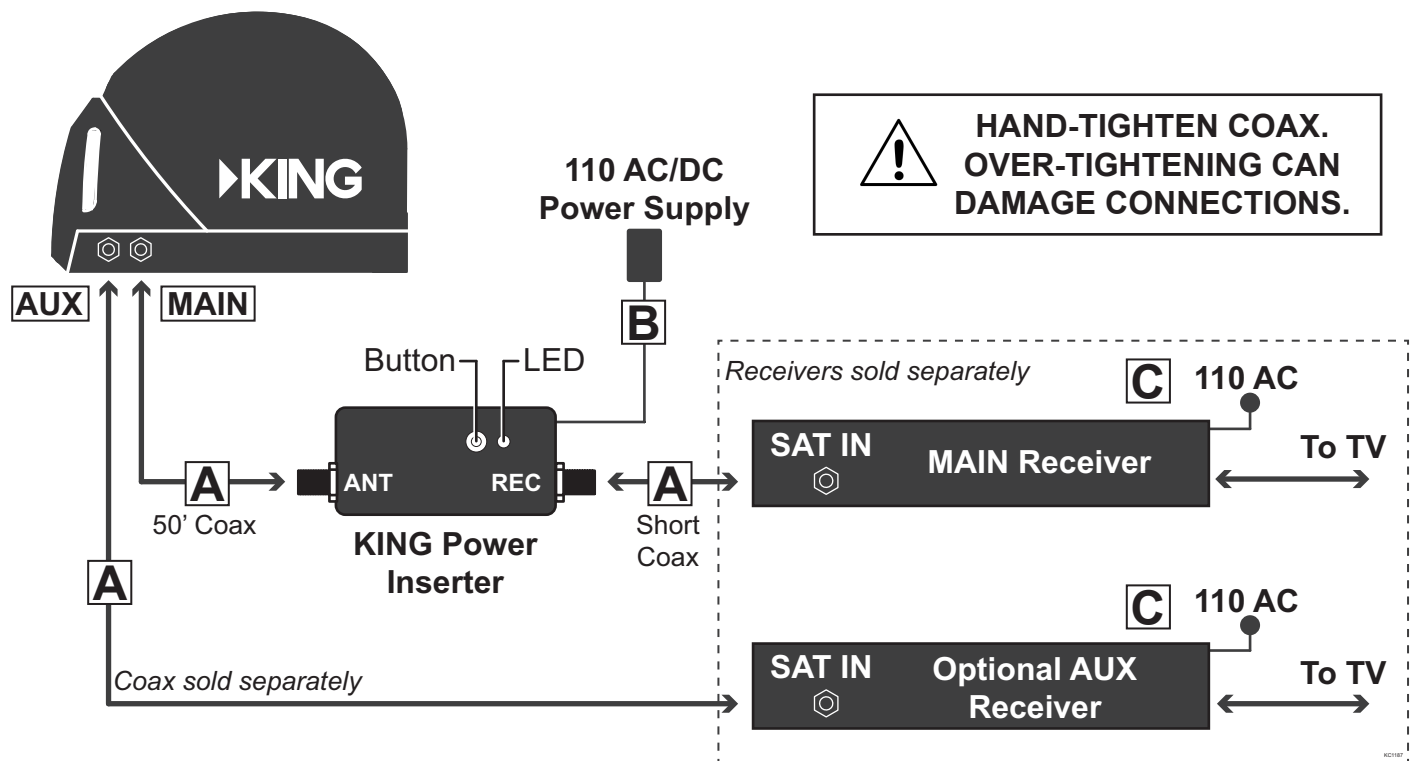

**AVOID SHARP BENDS WHEN ROUTING COAX!**

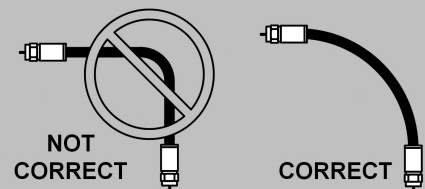

After connecting and plugging in all components, wait for the power inserter LED to turn steady green.

The Mobile Antenna Setup screen should appear on your TV.  
Go to the next page.

# ANTENNA CONFIGURATION

DISH with Wally receivers and the ViP models listed below (in the gray box) use mode 1. The KING One Pro comes factory preset for mode 1. If your antenna is new, you will not need to configure it.



**IF YOUR ANTENNA IS NEW, SKIP THIS STEP AND GO TO PAGE 8.**

MODE	SERVICE	SATELLITES	
1	DIRECTV	101, 119	DIRECTV subscribers
	DISH	61.5, 110, 119, 129	DISH subscribers with Wally, ViP211z, 211k, 411 or 211 receivers
2	DISH	110, 119, 129	DISH subscribers with receivers not listed in MODE 1
3	Bell TV	82, 91	Bell TV subscribers
4	DISH	61.5, 110, 119	DISH subscribers with receivers not listed in MODE 1



**IF YOUR ANTENNA IS NEW, SKIP THIS STEP AND GO TO PAGE 8.**

Make sure the LED is steady green



1



To enter Configuration Mode, press and hold (~3 sec) the power inserter button until one of the options below appears

2





Press and release as needed to choose Mode1

**MODE 1 (DISH)**

BLUE   pattern repeats...

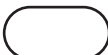

**MODE 2**

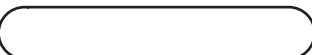
RED   RED   pattern repeats...



**MODE 3**

GREEN   GREEN   GREEN   pattern repeats...



**MODE 4**

RED   RED   RED   RED   pattern repeats...

3



Press and hold (~3 sec) until LED turns steady green



**Go to next page to start a scan.**

# OPERATION

## NEW AND UNACTIVATED WALLY RECEIVER



**IF YOUR RECEIVER IS NEW AND UNACTIVATED, START HERE.**

Otherwise go to **STANDARD OPERATION** on page 14.



**WHILE IN USE, DO NOT BLOCK THE ANTENNA UNIT'S LINE OF SIGHT TO THE SATELLITES IN THE SOUTHERN SKY AT ANY TIME!**

**SATELLITES IN SOUTHERN SKY**

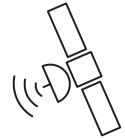

Place on a reasonably level surface

Pointing the handle approximately north may speed up scan time, but is not required for a successful search

**OBSTRUCTIONS**

**IMPORTANT!**  
If you move the antenna unit any time during or after the scan, you will have to repeat the scan.

**ANTENNA UNIT**

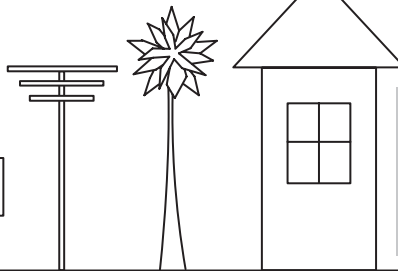
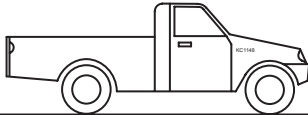

1. After connecting and turning on your equipment, the Wally Startup screens will appear (this may take several minutes).

### IMPORTANT!

Your TV screen may look different from what is shown in this manual. Screen information may vary depending on choices you make during the setup process.

For best results, follow the on-screen instructions.



Starting Up...

Starting up...

9999

2. Follow the on-screen instructions to pair your remote control.

**IMPORTANT!**  
If present, pull out the protective battery tab from the battery compartment on the back of the remote.

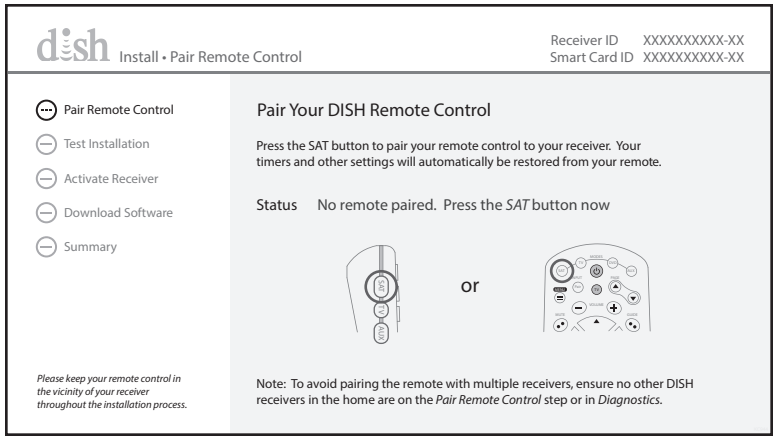

3. Use the arrow buttons on your remote to highlight "Next" and press Select.

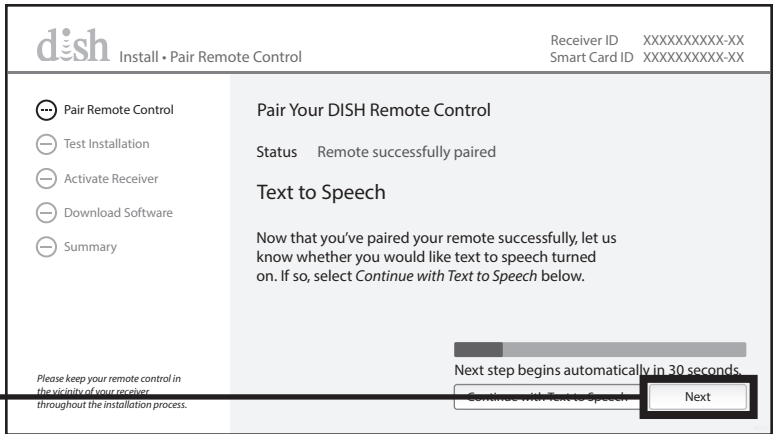

4. Follow the on-screen instructions to select your display resolution.

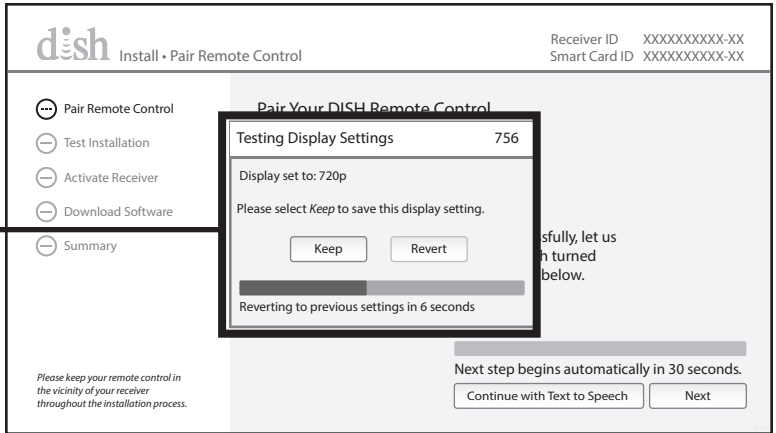

5. The Mobile Antenna Setup screen will appear.

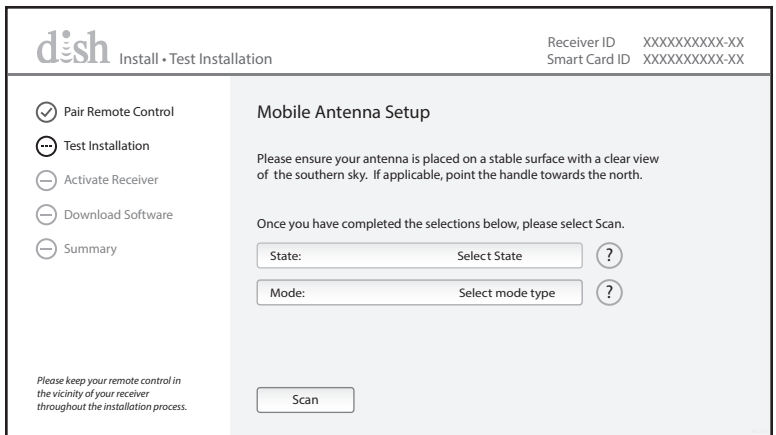

6. Use the arrow buttons on your remote to highlight the state menu. Press **Select** on your remote to open the state menu.

Use the arrow buttons on your remote to highlight the state you are currently in.

Press **Select** on your remote. (State selection will be saved.)

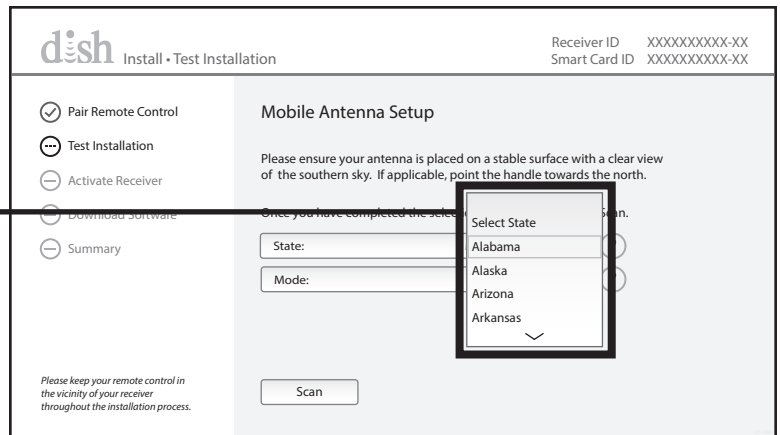

**NOTE FOR STEP 7: The mode menu may not be present on all receivers.**

The 110, 119, 129 trio will work for most of the country.

The antenna unit may have trouble locking onto the 129 when in the northeastern United States (you can use the Dish Diagnostics Screen after a scan to check this).

If the antenna unit does not lock onto the 129, choose the 61.5, 110, 119 trio.

Any programming from the 129 will not be available when using the 61.5, 110, 119 trio.

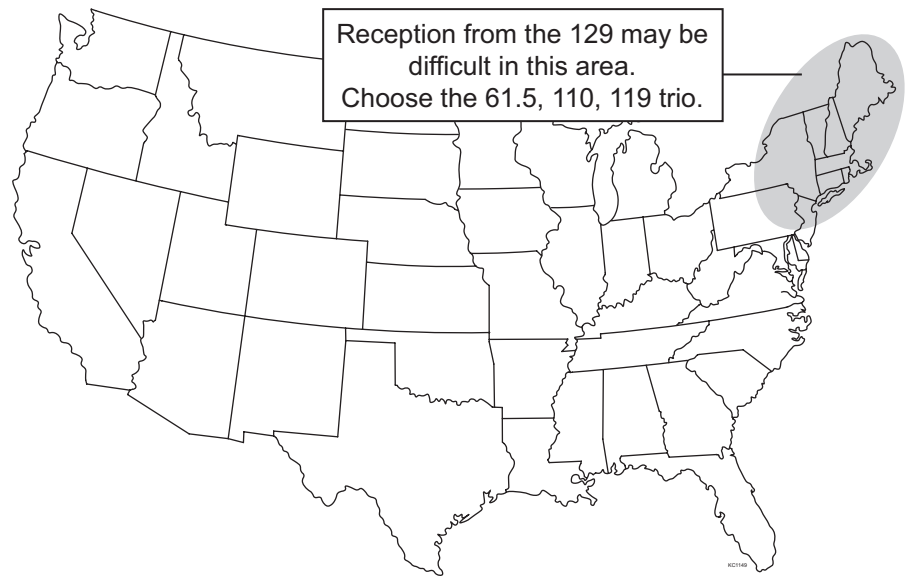

7. Use the arrow buttons on your remote to highlight the mode menu. Press **Select** on your remote to open the mode menu.

Use the arrow buttons on your remote to highlight the mode you wish to select.

Press **Select** on your remote.

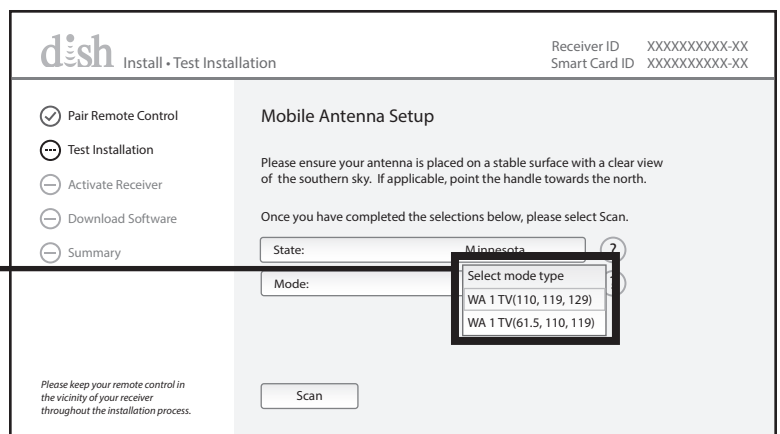

8. Use the arrow buttons to highlight "Scan" and press **Select**.

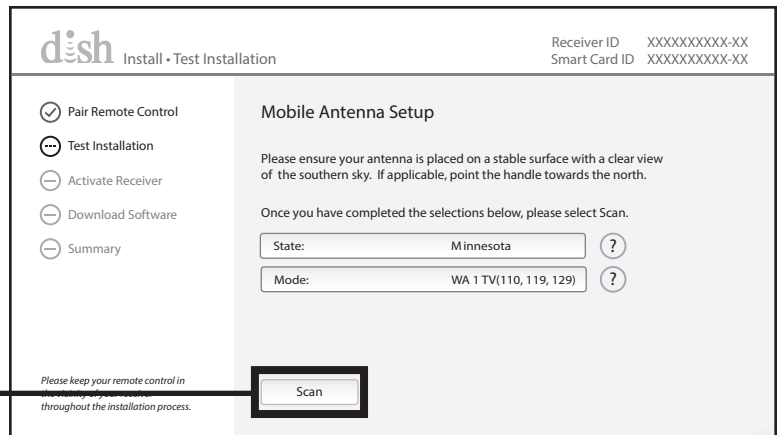

This screen will appear while the antenna scans for satellites.

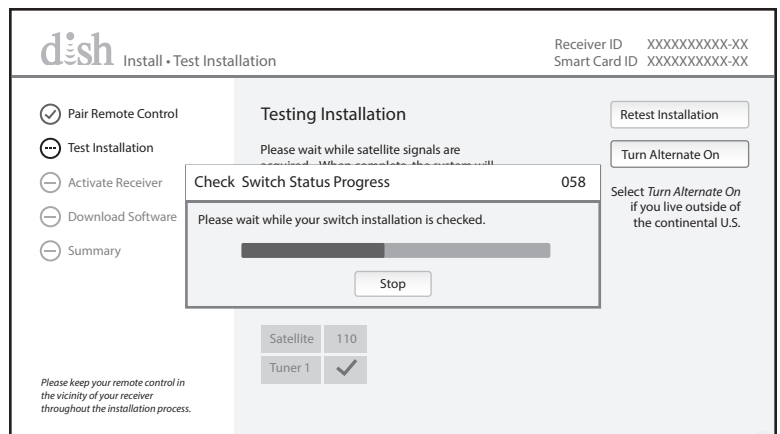

The satellite signals are being acquired. When complete, the system will proceed to the next step automatically.

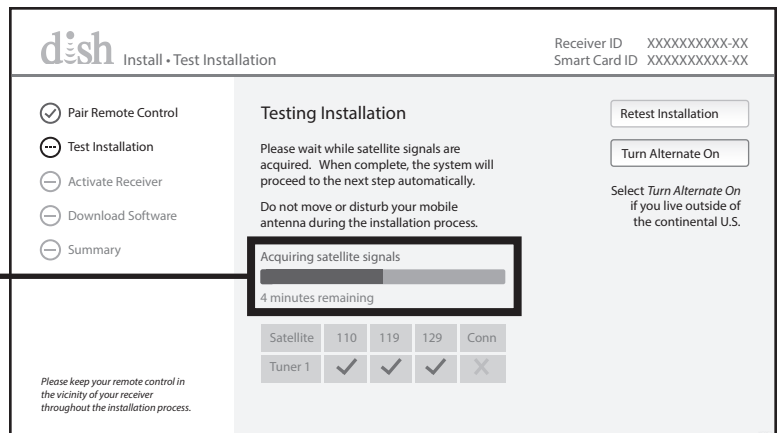

9. You are now ready to activate your receiver. Call a DISH mobile antenna specialist to activate your receiver.

**1-800-963-DISH (3474)**

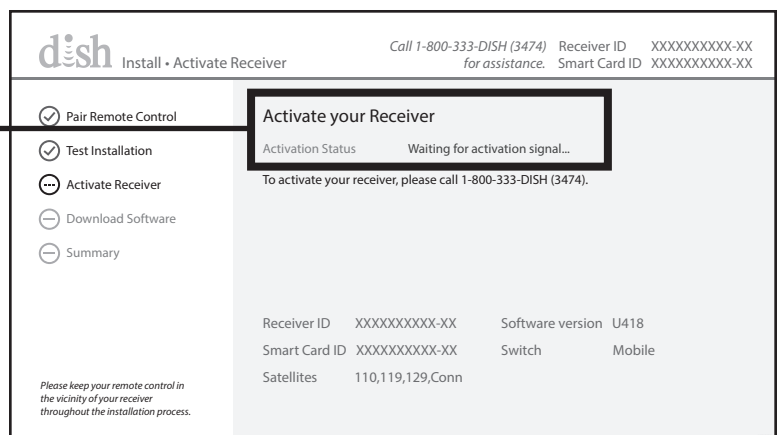

After calling to activate your receiver, a software download will begin.

Do not disturb or unplug your receiver during this process!

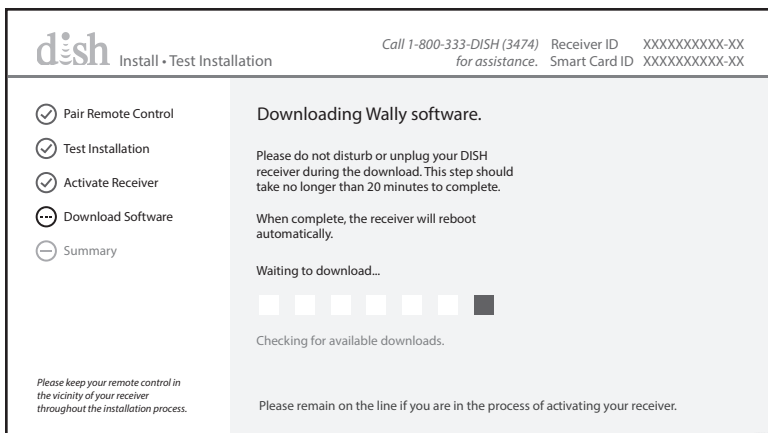

10. When the download is complete, the installation summary will appear.

Use the arrow buttons on your remote to highlight "Activate Receiver" and press **Select**.

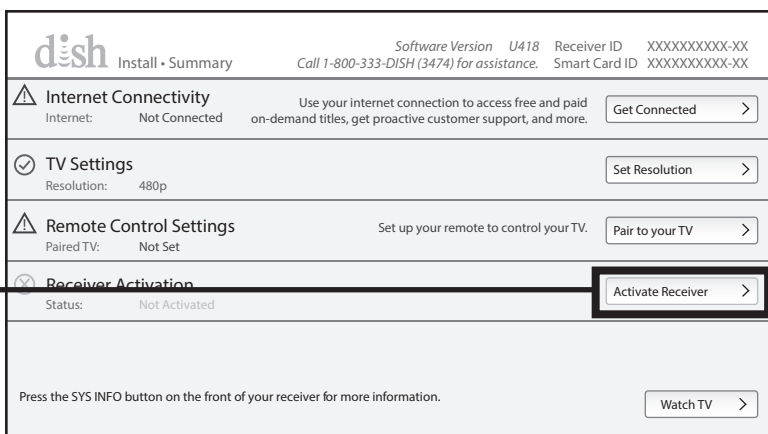

The receiver activates.

This may take a while. PLEASE BE PATIENT.

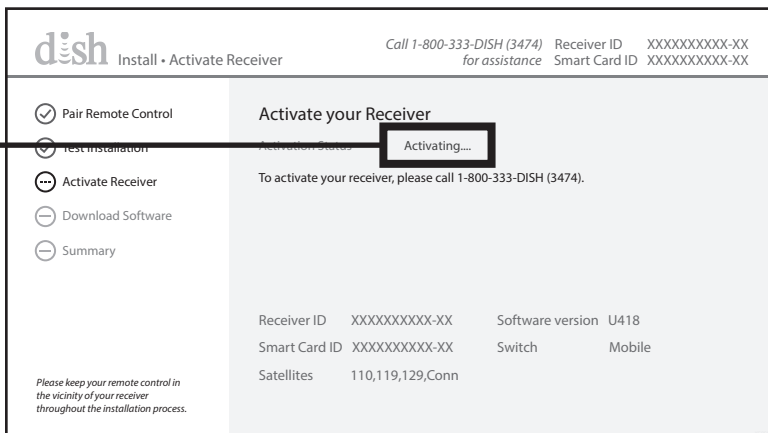

The installation summary screen confirms receiver activation.

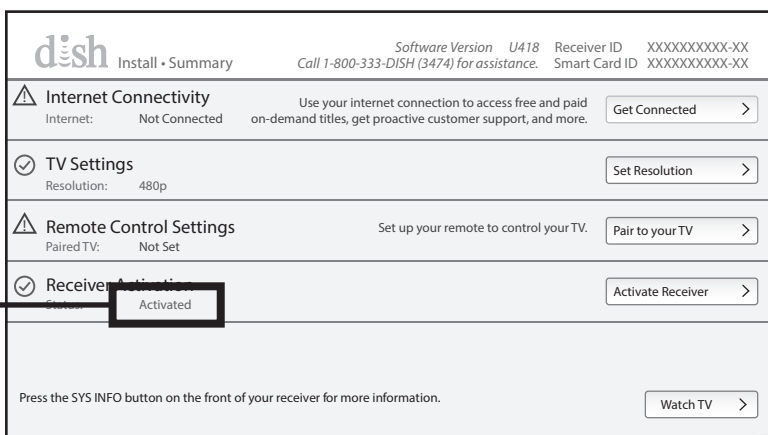

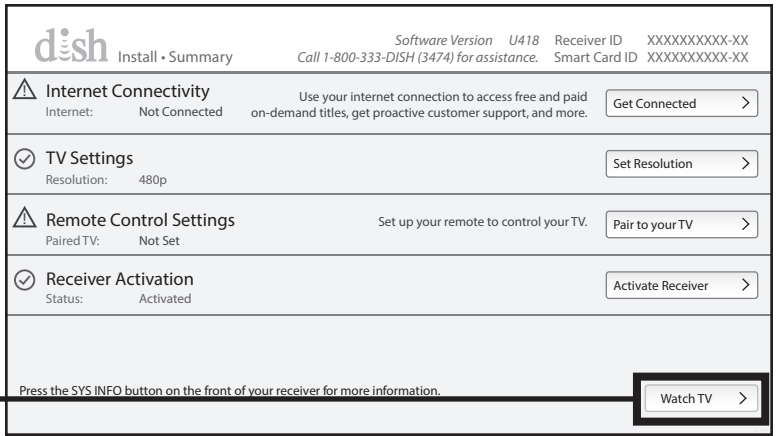

- Use the arrow buttons on your remote to highlight “Watch TV” and press **Select**.

The receiver will acquire signal.

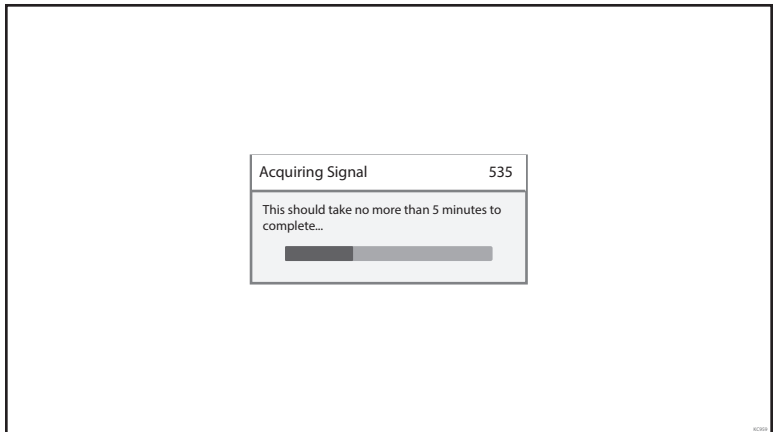

- Watch TV!



**NOTE:** Your Wally should have downloaded its program guide already. Check and make sure the full guide is available. If it is not, you will need to reset the Wally for it to download the full guide.

If there is a software update available for your Wally, it will automatically download when you put your Wally in standby mode.

**You can now use STANDARD OPERATION on page 14.**

## STANDARD OPERATION



**IF YOUR RECEIVER IS NEW AND UNACTIVATED, MAKE SURE TO DO THE FIRST-TIME SETUP PROCEDURE ON PAGES 8-13 FIRST.**



**WHILE IN USE, DO NOT BLOCK THE ANTENNA UNIT'S LINE OF SIGHT TO THE SATELLITES IN THE SOUTHERN SKY AT ANY TIME!**

**SATELLITES IN SOUTHERN SKY**

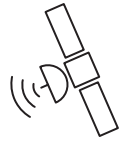

Place on a reasonably level surface

Pointing the handle approximately north may speed up scan time, but is not required for a successful search

**OBSTRUCTIONS**

**ANTENNA UNIT**

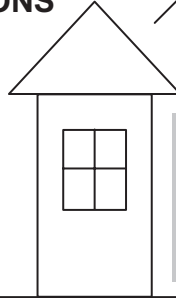
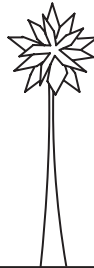
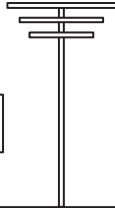
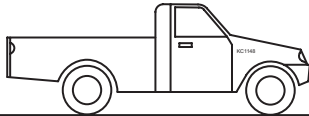

**IMPORTANT!**  
If you move the antenna unit any time during or after the scan, you will have to repeat the scan.

**NOTE:** This manual shows graphics for a DISH Wally receiver. If you have a ViP model receiver, you can access the KING One with ViP Receiver Owner's Manual by going to [kingconnect.com/support](http://kingconnect.com/support). Click on "Owners Manuals" and choose the manual for KING One with ViP receiver.

1. After connecting and turning on your equipment, the Wally Startup screens will appear (this may take several minutes).

**NOTE:** If the Wally Standby screen appears, press any button on your remote to continue.

### IMPORTANT!

Your TV screen may look different from what is shown in this manual. Screen information may vary depending on choices you make.

For best results,  
follow the on-screen instructions.

**Wally**<sup>TM</sup>

Starting Up...

Starting up...

9999

- After the Wally starts up, the Mobile Antenna Setup screen will appear.

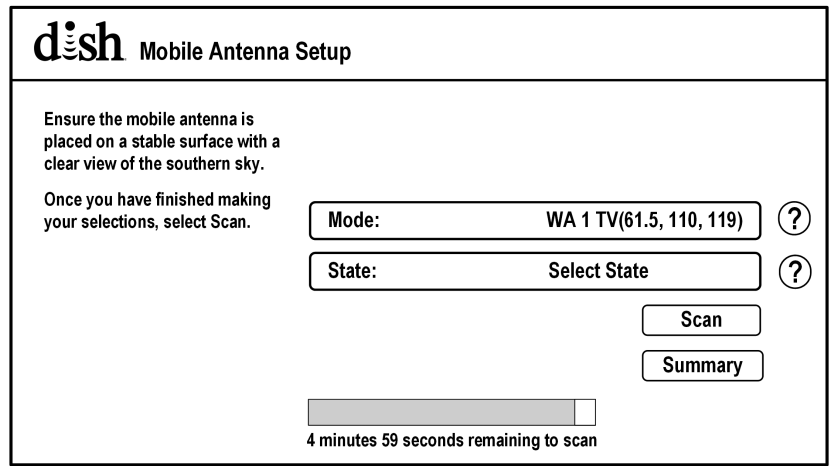

**NOTE FOR STEP 3: The mode menu may not be present on all receivers.**

The 110, 119, 129 trio will work for most of the country.

The antenna unit may have trouble locking onto the 129 when in the northeastern United States (you can use the Dish Diagnostics Screen after a scan to check this).

If the antenna unit does not lock onto the 129, choose the 61.5, 110, 119 trio.

Any programming from the 129 will not be available when using the 61.5, 110, 119 trio.

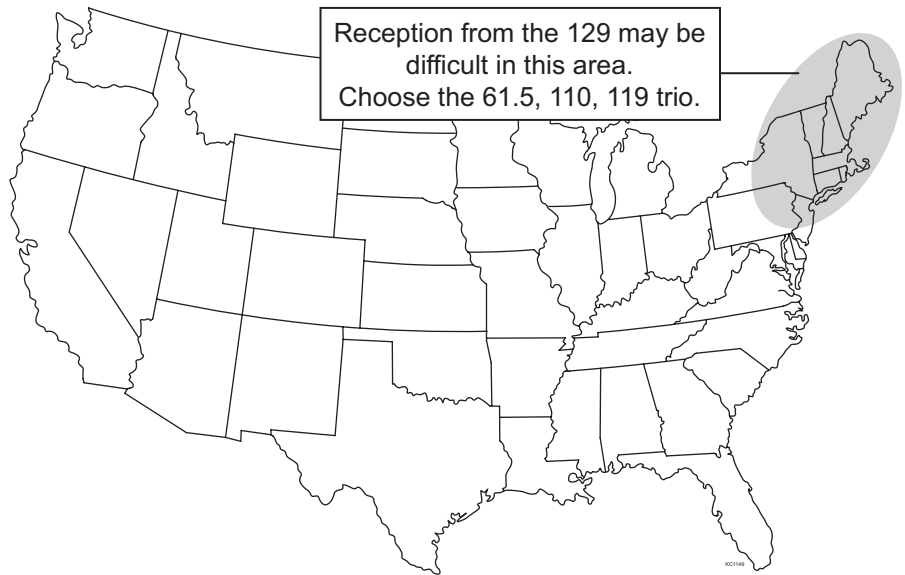

- Use the arrow buttons on your remote to highlight the mode menu. Press **Select** on your remote to open the mode menu.

Use the arrow buttons on your remote to highlight the mode you wish to select.

Press **Select** on your remote.

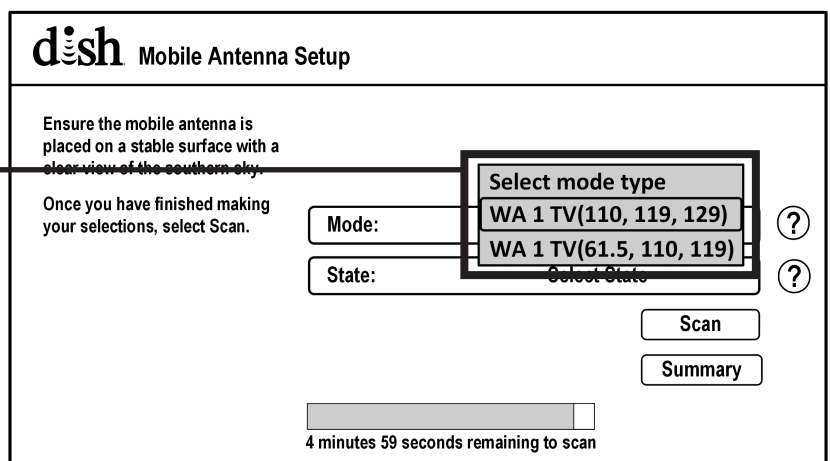

STANDARD OPERATION

4. Use the arrow buttons on your remote to highlight the state menu. Press **Select** on your remote to open the state menu.

Use the arrow buttons on your remote to highlight the state you are currently in.

Press **Select** on your remote. (State selection will be saved.)

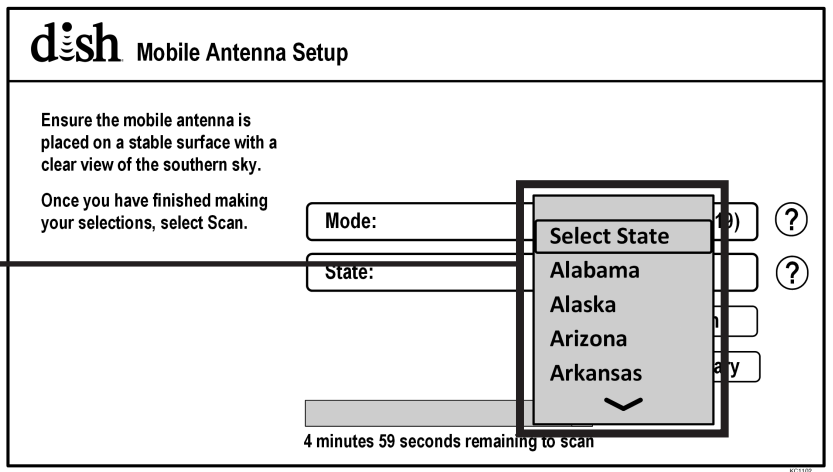

5. Use the arrow buttons on your remote to highlight "Scan."

Press **Select** on your remote.

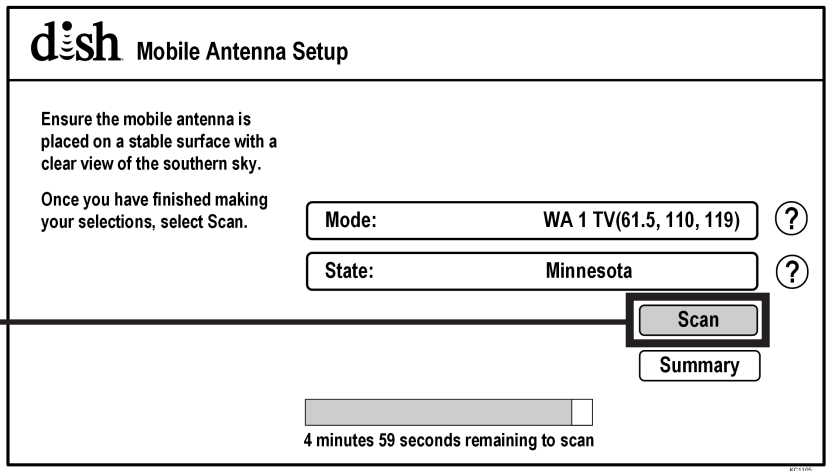

The scan will begin and may take up to several minutes to complete.

This screen will appear during the scan.

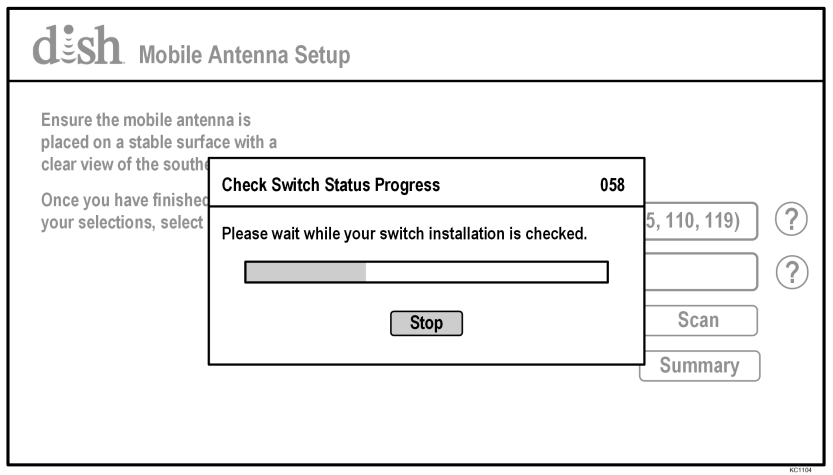

When the scan is complete, the Acquiring Signal screen will appear.

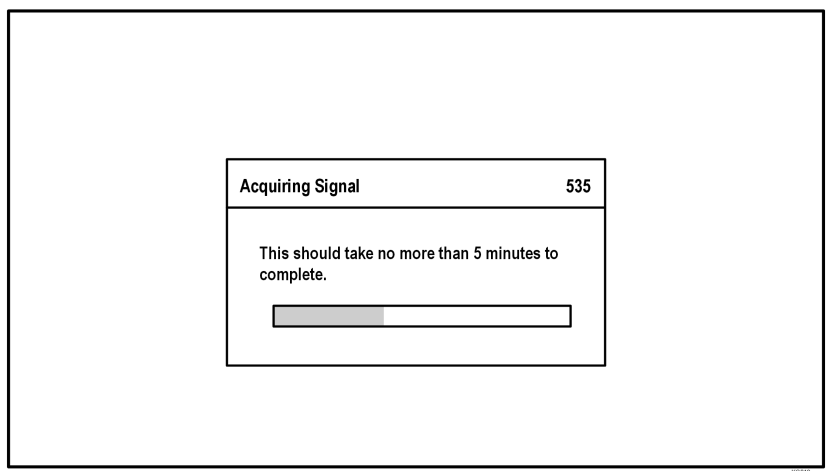

After your receiver has acquired the signal, the program guide will download. This may take up to 10 minutes to complete (potentially longer if an external hard drive is connected).

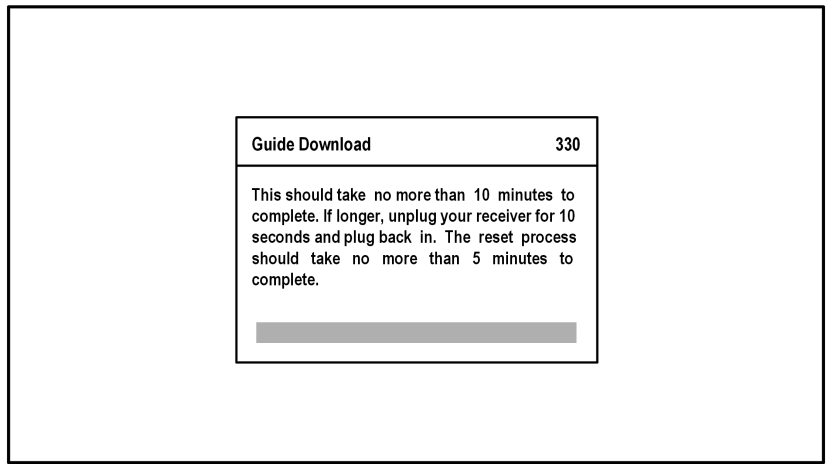

6. When the guide has downloaded, live TV will appear.

Enjoy!



### OPERATING NOTES:

If you move the KING One Pro while in use, or get a screen indicating complete signal loss, you will have to perform a new scan to restore programming by going to the Mobile Antenna Setup screen as follows:

Press the HOME button to return to the home page. Choose "Settings" and then "Diagnostics." Choose "Dish 3" and then "Test Installation 5." This will take you back to the Mobile Antenna Setup screen. Initiate a new scan.

When in the northeastern United States, television programming from the 129 satellite may not be available (see page 15).

If your system is inactive for an extended period of time, you may have to call DISH Customer Service at 1-800-333-DISH (3474) to reauthorize your receiver.



**If your receiver has not been used for a while the 013 error message may appear. Call 1-800-333-DISH (3474) and follow the prompts to reauthorize your receiver. Note that if channel 101 appears, scroll channel up or down to make sure 013 error message does not appear.**

**You can view your programming when your receiver has been authorized and the guide has finished downloading.**

## SECOND RECEIVER OPERATION

**IMPORTANT!** If your second receiver is new and unactivated, you must first connect it to the MAIN port and do an initial setup as described in the New and Unactivated Receiver Section starting on page 8.

### INITIAL SETUP FOR SECOND RECEIVER

1. Make sure your second receiver has been properly set up and activated (while connected to the MAIN port) as described in the New and Unactivated Receiver Section (page 8).
2. Connect your properly activated main receiver to the MAIN port. Run a scan to lock onto the satellites.
3. Connect the second receiver to the AUX port.
4. Run a check switch test on second receiver. When test is complete, save the results.

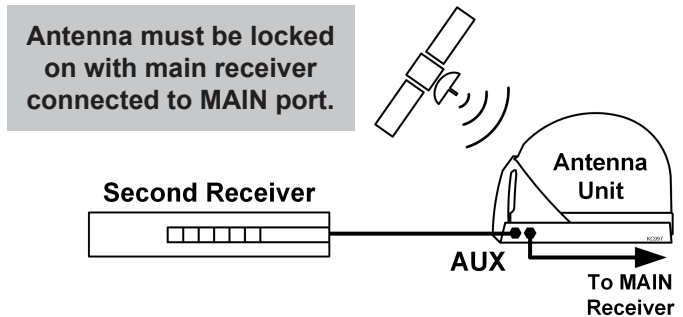

### DOWNLOADING PROGRAMMING TO THE SECOND RECEIVER

5. After completing the check switch test, reset the second receiver by pressing the POWER button on the front panel for 10 seconds. The receiver will reboot and go into sleep mode (green light on front panel will be off). Press **Select** to wake it up.

The receiver will then download the program guide to show only the channels available on the current satellite as determined by the channel selected on the main receiver. Downloading the new program guide can take up to five minutes to complete.

The channels available on the second receiver are determined by the channel/satellite selected on the main receiver. For example, if you select a channel on the main receiver that is broadcast from the 119 satellite, then the second receiver will be able to view any channel broadcast from the 119 satellite.

If you switch channels on the main receiver to one that is broadcast from a different satellite, (for example, your channel was broadcast from satellite 119 but your new channel is broadcast from the 110), the antenna will automatically switch to the 110 satellite and programming will be lost on the second receiver until you either:

- Select a channel on the main receiver that is broadcast from the previous satellite (satellite 119 in this example).
- (or)
- Reset the second receiver by running another check switch test to download the program guide for the newly selected satellite (satellite 110 in this example).

**NOTE:** If you choose a channel on the main TV that causes the antenna to switch satellites, you may have to run a check switch on the second receiver.

# ACCESSORIES (Sold separately - see the satellite antenna accessories page at [kingconnect.com](http://kingconnect.com))

## MB700 Quick Release Roof-Mount Kit

Allows you to easily use your KING One Pro as either a roof-mounted or portable antenna.

KING Antenna not included.

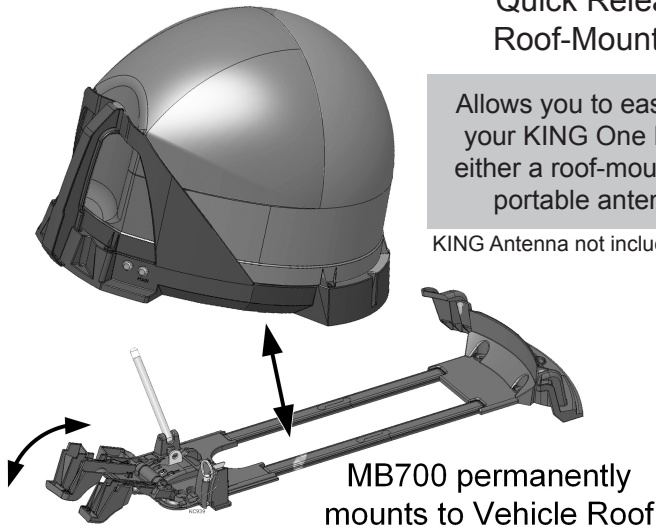

MB700 permanently mounts to Vehicle Roof

## MB500 Mounting Bracket

Includes (2)  
Hanger Brackets

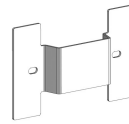

Allows hanging of antenna unit on vehicle window or included hanger bracket.

For stationary use only.  
Vehicle must not be in motion while antenna unit is on window or hanger bracket.

KING Antenna not included.

## CB1000 Carry Bag

KING One Pro fits securely inside. Features include zippered cover, foam padding, carry handles and pockets for cables, receiver and remote.

KING Antenna not included.



## TR1000 Tripod Mount

Allows you to position your KING One Pro almost anywhere for best line of sight to satellite. Keeps antenna off the ground away from moisture.

KING Antenna not included.



## MB160 Mounting Bracket

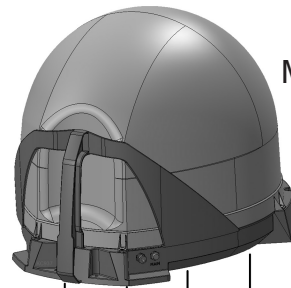

MB160 Mounts to  
Back of Vehicle

The KING One Pro is not compatible with the MB100 Mounting Bracket. Use of the MB100 will void warranty.

The use of any unauthorized mounting bracket will void warranty.

KING Antenna not included.

# TROUBLESHOOTING

## GENERAL

Symptom	Possible Cause	Troubleshooting
Antenna unit does not scan for satellites.	No power to antenna unit.	Make sure antenna unit is connected to power inserter.  Make sure power supply is plugged in and connected to power inserter.
Antenna unit scans but no picture on TV.	Improper connections made.	Make sure antenna unit is connected to power inserter, and power inserter is plugged in.  Make sure powered receiver is connected to TV and the power inserter.
Antenna unit scans but does not find satellite.	Line of sight obstruction.	Move antenna unit to have a clear view of the southern sky. Start a new scan.
Picture on TV goes in and out.	Temporary obstruction of signal.	Heavy rain or snow may cause loss of signal. Reception will improve as weather clears.  Make sure nothing is temporarily blocking view to the southern sky (like tree branches blowing in the wind).

If you connect or install the antenna unit using any of the vehicle's internal wiring/coax, and the antenna unit does not work properly, it could be the vehicle's wiring/coax. Connect a known good coax directly from the antenna unit to the power inserter and see if the problem goes away. If it does, the vehicle's wiring/coax is at fault. KING is not responsible for faulty vehicle wiring/coax.

## WALLY RECEIVERS

Symptom/Message	Possible Cause	Troubleshooting
"SmartCard Not Inserted" message (021) on startup.	SmartCard is not fully seated in Wally slot.	Your SmartCard is located on the left side of the Wally. Pull out the SmartCard and insert it back into the slot. Make sure the arrow on the SmartCard is facing up and is inserted first into the receiver. If there is not a SmartCard in your receiver please call 1-800-333-DISH.
My remote is not working.	Remote is in wrong mode.	If you think the remote is paired, but in the wrong mode, press the "SAT" button on the left side of the remote.
	Your batteries may need to be replaced.	Check to make sure the batteries are properly inserted in your remote. If "SAT" on the front top of the remote does not light up when you press the SAT button on the left side of the remote, replace the batteries.
	Your remote is not currently paired with your receiver.	To pair your remote, press the "SYS INFO" button on the front of the Wally and then press the "SAT" button on the left side of your remote.
Complete Signal Loss - 015A	Obstructions to the KING One Pro's view of the southern sky, such as tree branches, severe rain, etc.	Make sure nothing is blocking the KING One Pro's view of the southern sky, such as tree branches, severe rain, or other obstructions.
	Coax cable not connected properly between your Wally and the KING One Pro.	Check that the coax cable between your Wally and the KING One Pro is connected properly and hand-tightened.
	You have selected a local channel but are outside of its spot beam area.	First, verify you have reception by selecting a nationally broadcast channel (CNN, ESPN, etc.).  Then call DISH at 1-800-333-DISH to have your locals switched to your current area.
	KING One Pro has been moved.	If KING One Pro has been moved, initiate a new scan.
Channel Signal Loss - 004	KING One Pro has not tracked to the appropriate orbital slot upon channel change.	There may be an obstruction blocking signal from the newly chosen satellite.  Verify there are no obstructions, or move KING One Pro to have a better view of southern sky and initiate a new scan. Once your system has found its satellites, it may take a few minutes to download the electronic program guide and acquire signal before live TV appears.

Symptom/Message	Possible Cause	Troubleshooting
All Satellites Not Found - 150	Obstructions to the KING One Pro's view of the southern sky, such as tree branches, severe rain, etc.	Make sure nothing is blocking the KING One Pro's view of the southern sky, such as tree branches, severe rain, or other obstructions.
	Your physical location may be outside the footprint of the desired orbital slot.	Unplug the power cord of your receiver for 10 seconds and plug it back in. It may take up to 5 minutes for your receiver to power back on.
No Satellites Found - 151	Obstructions to the KING One Pro's view of the southern sky, such as tree branches, severe rain, etc.	Make sure nothing is blocking the KING One Pro's view of the southern sky, such as tree branches, severe rain, or other obstructions.
	Coax cable not connected properly between your receiver and the KING One Pro.	Check that the coax cable between your receiver and the KING One Pro is connected properly and hand-tightened.  Unplug the power cord of your receiver for 10 seconds and plug it back in. It may take up to 5 minutes for your receiver to power back on.
OTA Channel Signal Lost - 739	The signal has been lost for this over-the-air channel. This can be due to relocation or realignment of the antenna.	Reposition antenna into optimal position to get clearest signal. May need to scan again for OTA channels.
	Possible obstruction of the signal.	Remove obstruction from signal path.
OTA Tuner Module Not Detected - 978	An over-the-air (OTA) tuner module has been removed.	Reinstall OTA tuner module. When this is complete the Wally will request to be reset. Select YES to reset the Wally.
Local Channels Interrupted - 536		Call DISH at 1-800-333-DISH to have your locals switched to your current area.
Missing Channels.	The electronic program guide may not be set to "My Channels."	Press the GUIDE button on your remote twice to display the "Favorite Channels" menu. Select "None" or one of your favorite channels list.
	You may not have the orbital slots required to view the missing television programming.	Confirm that you subscribe to the missing channel by using <a href="http://dish.com/mychannels">dish.com/mychannels</a> .
Low signal strength.	Because of the small size of the highly portable KING One Pro, signal strength may not be as strong as with a fixed home antenna.	N/A

<b>Symptom/Message</b>	<b>Possible Cause</b>	<b>Troubleshooting</b>
Unable to Access Feature - 024	Feature not downloadable.	Keep receiver in standby for 1 hour.
Sporting Event Blackout - 744	Blackout patterns are applied based on the physical address on your account. Events outside the area surrounding your physical address may not be available.	N/A
Outside of Viewing Area - 120	You are outside of the viewing area of currently available channels.	Call DISH at 1-800-333-DISH to have your locals switched to your current area.

# LIMITED WARRANTY

KING One Pro Satellite Antennas are thoroughly inspected and tested before leaving the factory, and are covered by the following limited warranty from the date of original purchase:

- Two-year parts warranty: The customer is not responsible for the cost of replacement parts if the original part is determined to be defective under the terms of the warranty. The customer is responsible for the cost of replacement parts after two years.
- One-year labor warranty: The customer is not responsible for labor costs to repair unit if labor is performed within the labor warranty period. The customer is responsible for all labor costs after one year.

Only KING and certified dealers may perform warranty evaluations and repairs. Depending upon the problem, KING may authorize a dealer to perform the necessary repairs. Any warranty labor outside of that performed at the factory is not covered unless 1) the product has been installed by an authorized dealer/installer or OEM manufacturer and 2) the dealer/installer receives prior authorization to perform the repair.

A certified dealer must not perform any repair without first contacting KING for a Service Order Number. KING will advise the dealer on how to proceed with any repairs.

Should any trouble develop during the warranty period, contact KING at (952) 345-8147. You must contact KING before the warranty period expires. The customer must supply proof of purchase (such as a dated sales receipt) when requesting warranty service. If the customer cannot supply proof of purchase, warranty period shall start 30 days after date of manufacture.

If it is determined that the unit needs to be returned to KING, customer must return COMPLETE product, freight prepaid, to: **KING, 11200 Hampshire Avenue South, Bloomington, MN 55438-2453.**

If inspection shows the trouble is caused by defective workmanship or material, KING will repair (or at its option, replace) without charge.

When returning product, KING will supply an RMA number (Return Merchandise Authorization). This number must be clearly written on the box. Failure to clearly write RMA number on box may result in delays in processing claim. Along with product, customer should include in the box: his/her name, address, daytime phone number, proof of purchase and description of the problem.

This warranty does not cover installation and external wiring, or remanufactured units. This warranty does not cover damage caused by the use of an accessory other than a KING accessory designed for the product. This warranty is not transferable from the original owner.

Due to the expanding and changing TV market, KING cannot be held responsible for changes made to satellite services. Software updates to address such issues are not covered under warranty.

This warranty also does not apply where:

- The product has been abused, misused, improperly installed or improperly maintained.
- The product has been used with an accessory other than a KING accessory designed for the product.
- Repairs have been made or attempted by others that are not certified by KING to do such repairs.
- Repairs are required because of normal wear and tear.
- Alterations have been made to the product.
- The product or any associated component has been opened without authorization or disassembled to any degree.
- Damage has been caused by power washing.
- Circumstances beyond the control of KING cause the product to no longer operate correctly.
- Customer is not the original owner.

In no event shall KING be liable for any indirect, incidental, or consequential damages from the sale or use of the product. This disclaimer applies both during and after the term of this warranty.

KING disclaims liability for any implied warranties, including implied warranties of "merchantability" and "fitness for a specific purpose," after the term of this warranty.

This warranty gives you specific legal rights, and you may also have other rights, which vary from state to state. Some states do not allow the exclusion or limitation of incidental or consequential damages, so the above limitation or exclusion may not apply to you. Some states do not allow limitations on how long an implied warranty lasts, so the above limitation may not apply to you.

# FCC GUIDELINES

This equipment has been tested and found to comply with the limits for a Class B digital device, pursuant to part 15 of the FCC Rules. These limits are designed to provide reasonable protection against harmful interference in a residential installation. This equipment generates, uses and can radiate radio frequency energy and, if not installed and used in accordance with the instructions, may cause harmful interference to radio communications. However, there is no guarantee that interference will not occur in a particular installation. If this equipment does cause harmful interference to radio or television reception, which can be determined by turning the equipment off and on, the user is encouraged to try to correct the interference by one or more of the following measures:

- Reorient or relocate the receiving antenna.
- Increase the separation between the equipment and the receiver.
- Connect the equipment into an outlet on a circuit different from that to which the receiver is connected.
- Consult the dealer or an experienced radio/TV technician for help.

**Simply better, by design.™**



---

11200 Hampshire Avenue South, Bloomington, MN 55438  
PH 952.922.6889 || FAX 952.922.8424 || [kingconnect.com](http://kingconnect.com)

©2019 KING

23433 Rev A

All trademarks are the sole property of their respective owners.