

dish || tailgater^{PRO}

DTP4900 & DTP4950 Owner's Manual

This manual contains detailed information on your DISH Tailgater Pro.

To start using your DISH Tailgater Pro right away,
see the Quick Reference Guide.



To subscribe to programming or for assistance with using the
DISH Tailgater Pro, call 1-800-963-DISH (3474).

dish[™]
outdoors

Designed and Manufactured by **KING**

PRODUCT REGISTRATION

To provide ongoing technical support and to better facilitate warranty processing, please register your product at kingconnect.com/support.

Go here



and click on “Product Registration”

NOTE: This manual shows graphics for a DISH® Wally® receiver. If you have a ViP® model receiver, you can access the DISH® Tailgater® with ViP Receiver Owner’s Manual by going to kingconnect.com/support. Click on “Owners Manuals” and choose the manual for DISH Tailgater with ViP receiver.

TABLE OF CONTENTS

| | |
|---|-------|
| INTRODUCTION | 2 |
| IMPORTANT SAFETY INSTRUCTIONS | 2 |
| CONTENTS | 2 |
| APPLY RUBBER FEET TO ANTENNA UNIT | 3 |
| ABOUT SIGNAL LOSS | 3 |
| ABOUT SATELLITE TV RECEPTION | 4 |
| CONNECT RECEIVER TO TV | 4 |
| CONNECT ANTENNA UNIT TO RECEIVER | 5 |
| OPERATION WITH NEW AND UNACTIVATED RECEIVER | 6-11 |
| STANDARD OPERATION | 12-15 |
| SECOND RECEIVER OPERATION | 16 |
| PROPER CARE OF YOUR EQUIPMENT | 18 |
| SECURITY | 18 |
| ACCESSORIES | 18-19 |
| ROOF INSTALLATION | 20-23 |
| TROUBLESHOOTING | 24-26 |
| MANUFACTURER’S LIMITED WARRANTY | 27 |
| FCC GUIDELINES | 28 |

INTRODUCTION

Thank you for choosing DISH and the premium DISH Tailgater Pro Portable HDTV System!

You are about to experience the excitement of DISH satellite television programming and the convenience of the DISH Tailgater Pro portable antenna, which delivers the very best HD picture and sound quality wherever you go.

NEW AND UNACTIVATED RECEIVERS: First-time use should be at a location with good phone service, as you will need to call a DISH mobile antenna specialist to activate your receiver (page 9).

IMPORTANT SAFETY INSTRUCTIONS

1. Please read this Owner's Manual thoroughly before using the DISH Tailgater Pro.
2. Keep this Owner's Manual and the included Quick Reference Guide in a safe place for future reference.
3. Follow all instructions and warnings. Set up and operate the DISH Tailgater Pro in accordance with the instructions.
4. Do not power wash the DISH Tailgater Pro. Do not submerge the DISH Tailgater Pro or place in standing water. Hand wash only with mild soap and water. See page 18 for additional care instructions.
5. Do not operate near any indoor or outdoor heat source such as radiators, heat registers, stoves, barbecues, campfires, or other items that produce heat.
6. Servicing may be required if the unit has been dropped or damaged in any way or if the unit does not operate normally. Call KING Customer Service at (952) 345-8147.
7. Tighten all of the coax cable connections only by hand. If you use a wrench, you may over-tighten the connections and damage your equipment.
8. To avoid risk of electric shock, unplug your receiver before connecting/disconnecting the DISH Tailgater Pro in damp or wet conditions.

CONTENTS

Antenna Unit

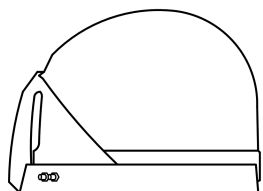



(3) Rubber Feet



50' RG-6 Coax Cable



 Owner's Manual

 Quick Reference Guide

 Registration Card

You will also need (sold separately):

DISH Programming Subscription 

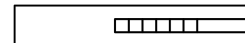
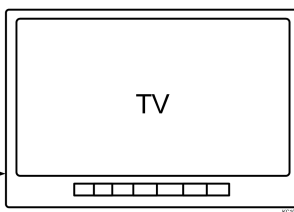
DISH HD Solo Receiver*  Receiver to TV Cable(s) 

NOTE: The DTP4950 includes the Wally receiver and cables.

*Model ViP 211z, ViP211k, ViP211, 411 or Wally receiver
Receiver models compatible with the DISH Tailgater Pro may change.
This list may not be complete.
Please visit kingconnect.com/support for the most up-to-date receiver information.

APPLY RUBBER FEET TO ANTENNA UNIT

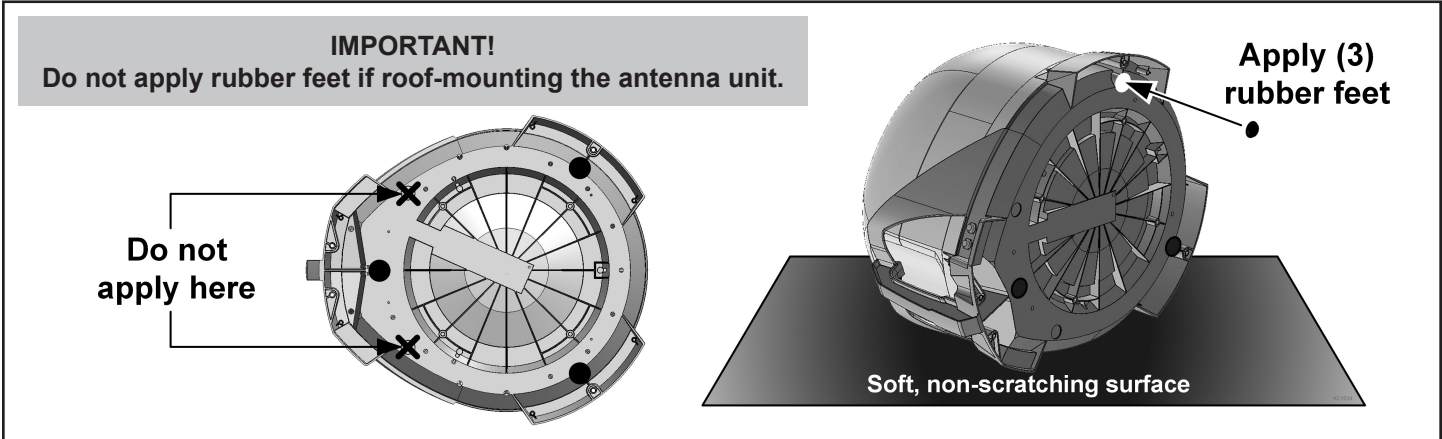

ABOUT SIGNAL LOSS

OBSTRUCTIONS

The DISH Tailgater Pro requires an unobstructed view of the southern sky for the best signal reception.

Be sure to place the DISH Tailgater Pro in a location free from obstructions such as people, trees, buildings, vehicles, etc. This will allow for the strongest signal and will help prevent any interruption to your programming. Point the handle approximately north to speed up scan time.

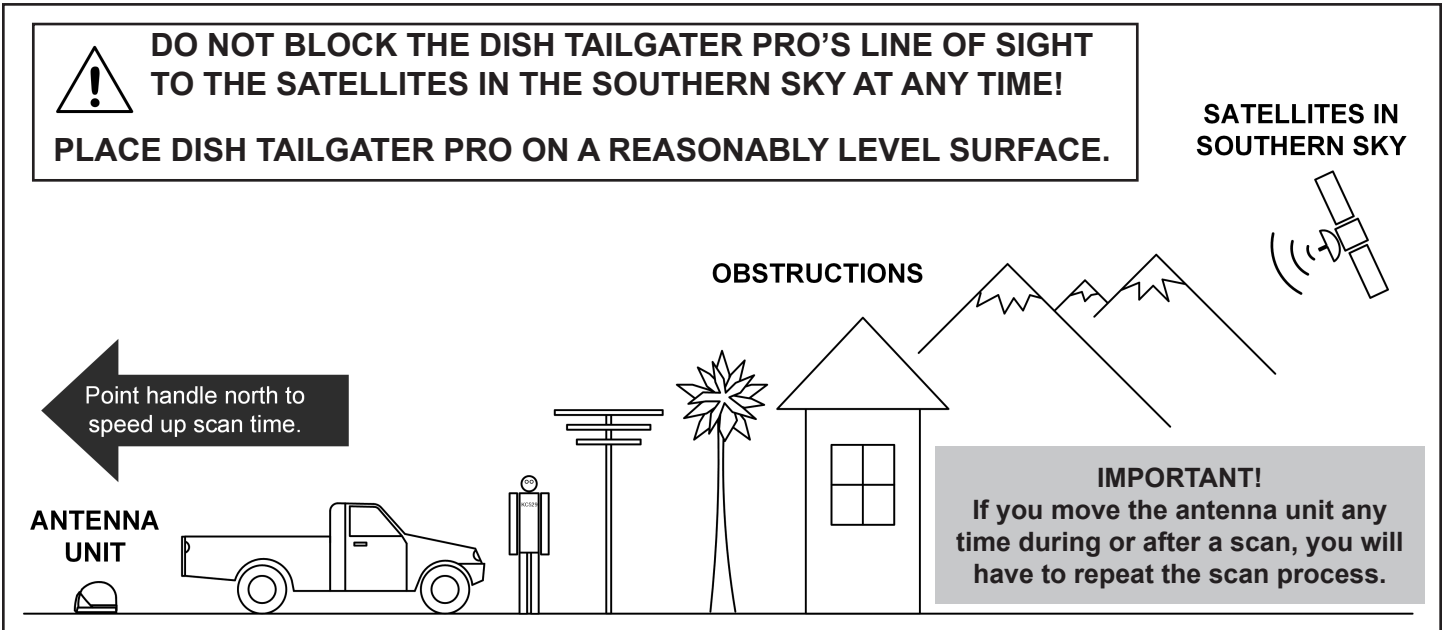

RAIN AND SNOW FADE

Though rare, heavy rain, snow, or dense cloud cover can reduce the satellite signal, which may interrupt your programming. Your programming should return as conditions improve.

ABOUT SATELLITE TV RECEPTION

Satellite television uses satellites in a geostationary orbit over the earth. This type of orbit enables the satellites to stay aligned over one place on the surface of the earth and to transmit your television programming to the DISH Tailgater Pro when pointed at the appropriate satellite.

WALLY RECEIVERS: Your television programming is delivered from up to 3 of 4 satellites located at the 61.5°, 110°, 119° and 129° west longitudes. You will choose between two groups of satellites based on where you are in the country: the 61.5, 110, 119 trio and the 110, 119, 129 trio. A map to assist with this choice is included in the operating section of this manual.

The DISH Tailgater Pro will automatically find and switch between satellites as you change channels to offer you the ideal viewing experience.

CONNECT RECEIVER TO TV



DO NOT PLUG IN OR TURN ON RECEIVER AT THIS TIME.

1. Connect your DISH HD Solo Receiver (ViP211z, ViP211k, ViP211, 411 or Wally)* to your TV using the best connection type supported by your TV. (See your TV owner's manual for its connection options. Connection type and location may vary by model.)**

Back of Wally Receiver

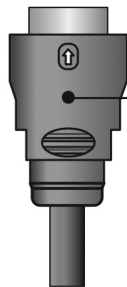
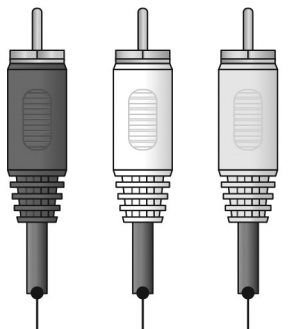
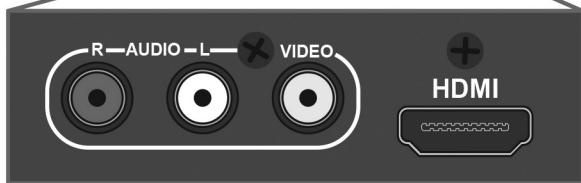

HDMI® Cable
(High-Definition Connection)

OR

Composite Cables
(Standard-Definition Connection)

Go here



and click on
"Receiver Compatibility"

* Receiver models compatible with the DISH Tailgater Pro may change. This list may not be complete. Please visit kingconnect.com/support for the most up-to-date receiver information.

** Your receiver may also have standard-definition "TV SET OUT" and "S-VIDEO" ports, and high-definition "COMPONENT" ports to view video. See your receiver's Owners Manual for more information.

Images shown may vary by receiver model.

CONNECT ANTENNA UNIT TO RECEIVER

The DISH Tailgater Pro requires an unobstructed view of the southern sky for signal reception. Be sure to place the DISH Tailgater Pro in a location free from obstructions such as trees, buildings, etc. (see page 3). Point the handle approximately north to speed up scan time.



HAND-TIGHTEN COAX. OVER-TIGHTENING CAN DAMAGE CONNECTIONS.

1. Connect one end of the supplied RG-6 coax cable to the MAIN port on the DISH Tailgater Pro and place in position. It is recommended you use only the supplied RG-6 coax cable.
2. Connect other end of the supplied RG-6 coax cable to the **SATELLITE IN** port on your receiver.

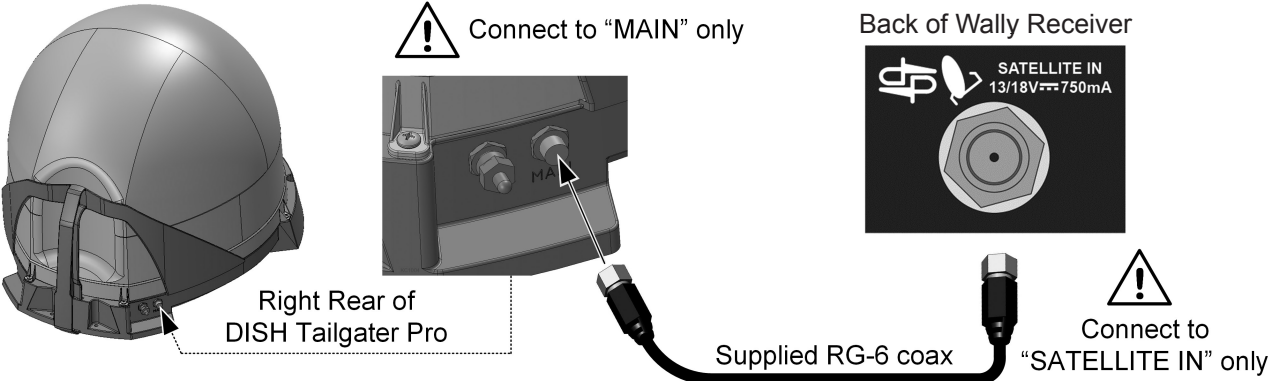

- Do not put the DISH Tailgater Pro where it can be bumped, knocked over or struck by a person or vehicle.
- Do not put the DISH Tailgater Pro near any heat sources.
- Do not route coax cable where it can be tripped on or run over by a vehicle.
- Do not over-tighten coax cable connections.
- Do not put sharp bends or kinks in coax cable.

NOTE: Place the DISH Tailgater Pro on a stable and reasonably level surface with a clear view of the southern sky. When placing the DISH Tailgater Pro in position, be sure surface is dry and free of loose dirt or sand.

3. Plug your receiver into a 110 volt AC power source.

- The green power light on your receiver should illuminate or begin cycling on and off.
- Wait for the green light to turn solid. This may take up to two minutes.
- If it does not turn solid, power on your receiver using the front panel POWER button. (On ViP211z models, this is located behind the door panel.)

4. Plug in and turn on your TV.

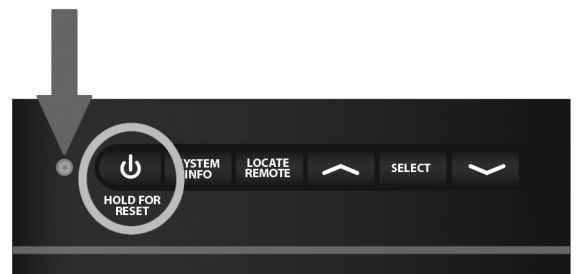

Front of Wally Receiver

In your TV's input selection menu, choose the input that matches the connection from your receiver. (Example: If using an HDMI cable from your receiver, choose the HDMI input on your TV.) See your TV's Owners Manual for details.

OPERATION WITH NEW AND UNACTIVATED RECEIVER



IF YOUR RECEIVER IS NEW AND UNACTIVATED, START HERE.

Otherwise go to **STANDARD OPERATION** on page 12.



WHILE IN USE, DO NOT BLOCK THE DISH TAILGATER PRO'S LINE-OF-SIGHT TO THE SATELLITES IN THE SOUTHERN SKY AT ANY TIME!

SATELLITES IN SOUTHERN SKY

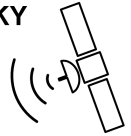

OBSTRUCTIONS

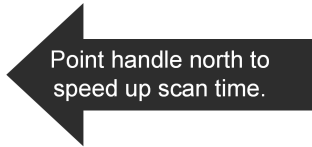

ANTENNA UNIT

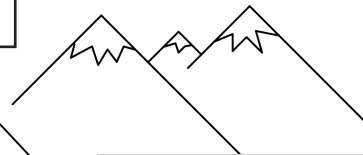
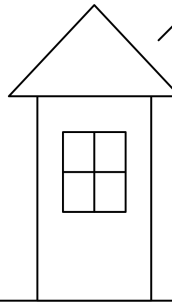
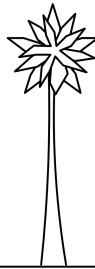
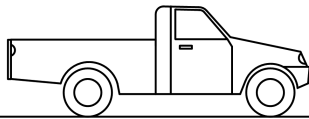

IMPORTANT!
If you move the antenna unit any time during or after the scan, you will have to repeat the scan.

NOTE: This manual shows graphics for a DISH Wally receiver. If you have a ViP model receiver, you can access the DISH Tailgater with ViP Receiver Owner's Manual by going to kingconnect.com/support. Click on "Owners Manuals" and choose the manual for DISH Tailgater with ViP receiver.

1. After connecting and turning on your equipment as instructed on pages 4-5 the Wally Startup screens will appear (this may take several minutes).

IMPORTANT!

Your TV screen may look different from what is shown in this manual. Screen information may vary depending on choices you make during the setup process.

For best results, follow the on-screen instructions.



- Follow the on-screen instructions to pair your remote control.

IMPORTANT!
If present, pull out the protective battery tab from the battery compartment on the back of the remote.

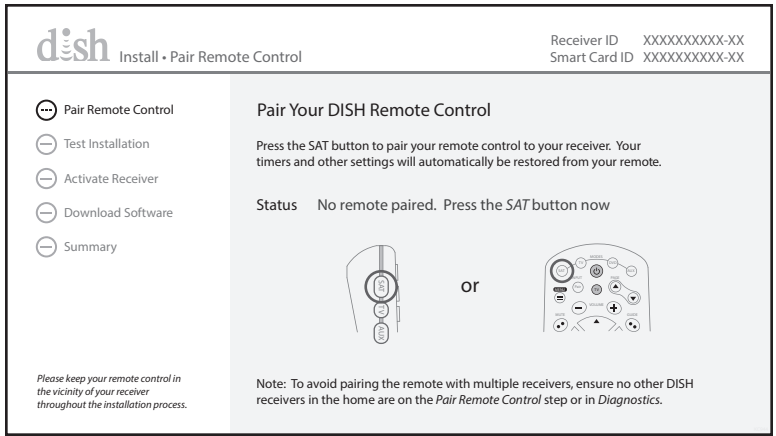

- Use the arrow buttons on your remote to highlight "Next" and press **Select**.

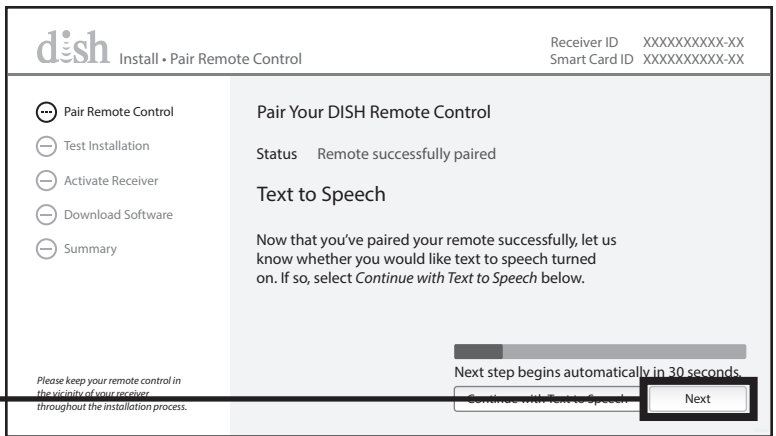

- Follow the on-screen instructions to select your display resolution.

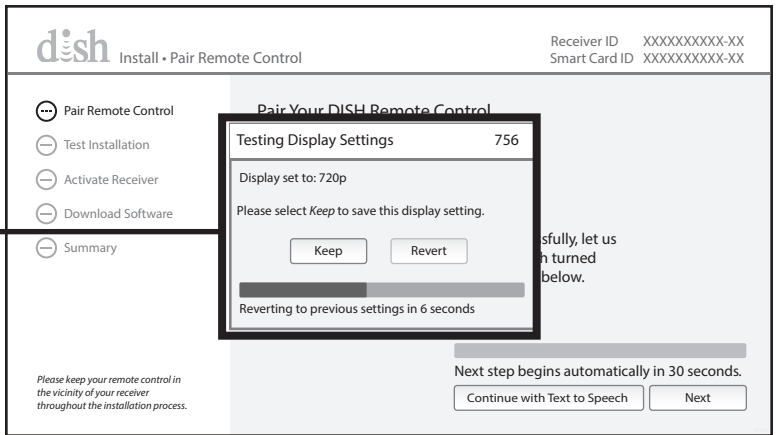

- The Mobile Antenna Setup screen will appear.

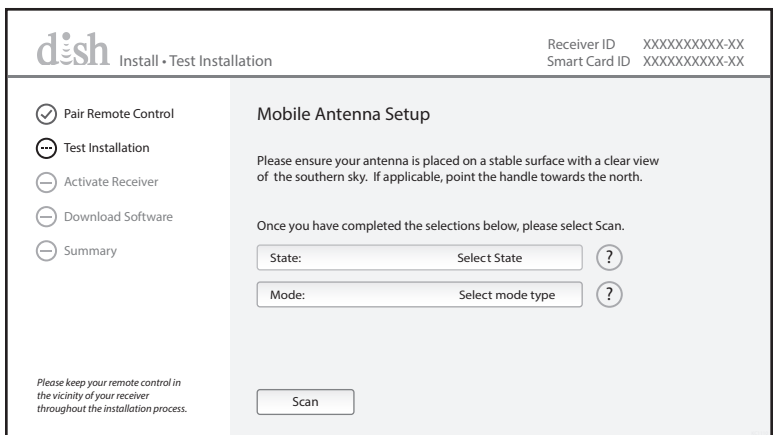

6. Use the arrow buttons on your remote to highlight the state menu. Press **Select** on your remote to open the state menu.

Use the arrow buttons on your remote to highlight the state you are currently in.

Press **Select** on your remote. (State selection will be saved.)

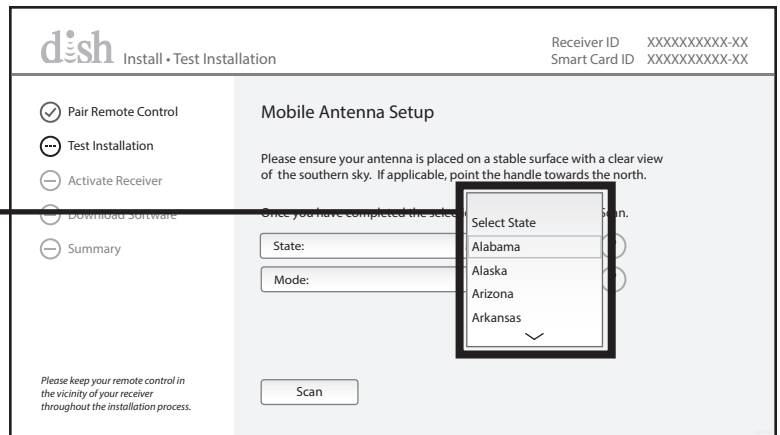

NOTE FOR STEP 7:

The 110, 119, 129 trio will work for most of the country.

The antenna unit may have trouble locking onto the 129 when in the northeastern United States (you can use the Test Installation Screen after a scan to check this).

If the antenna unit does not lock onto the 129, choose the 61.5, 110, 119 trio.

Any programming from the 129 will not be available when using the 61.5, 110, 119 trio.

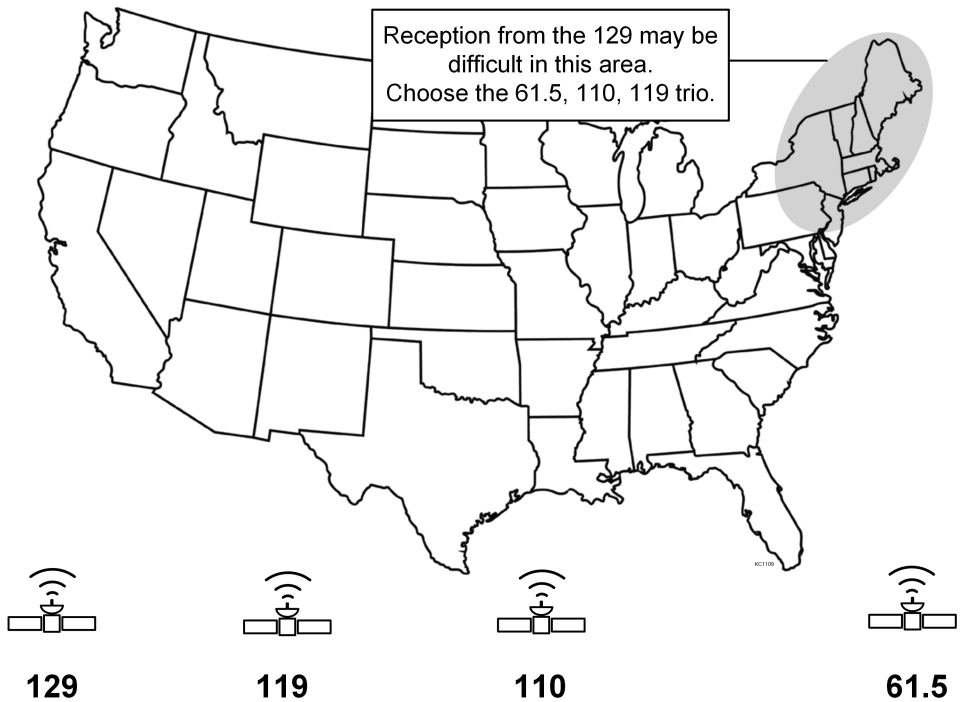

7. Use the arrow buttons on your remote to highlight the mode menu. Press **Select** on your remote to open the mode menu.

Use the arrow buttons on your remote to highlight the mode you wish to select.

Press **Select** on your remote.

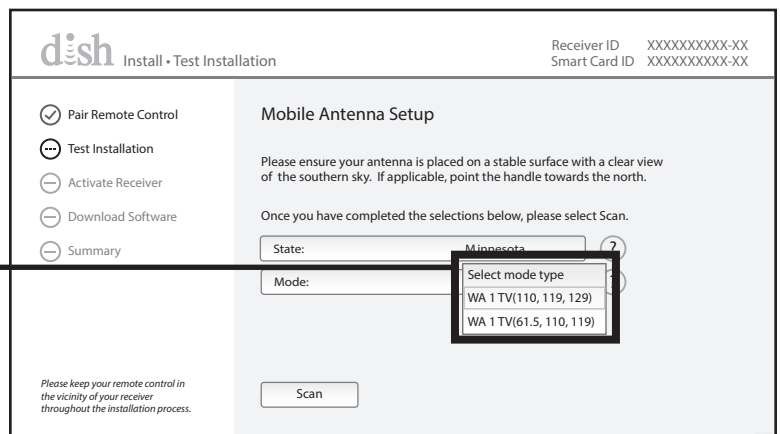

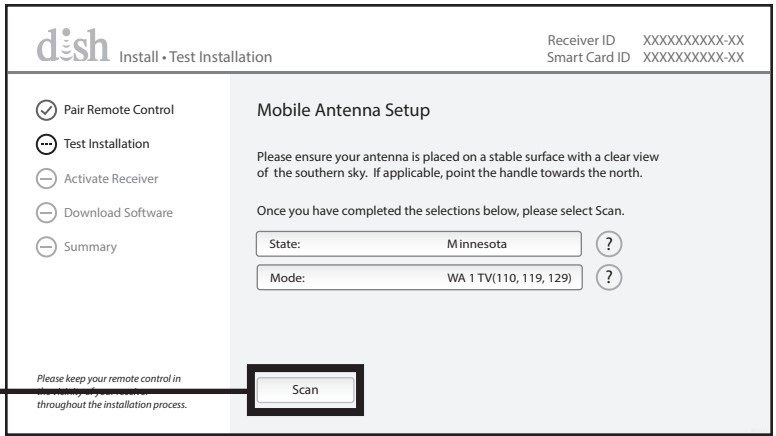

8. Use the arrow buttons to highlight "Scan" and press **Select**.

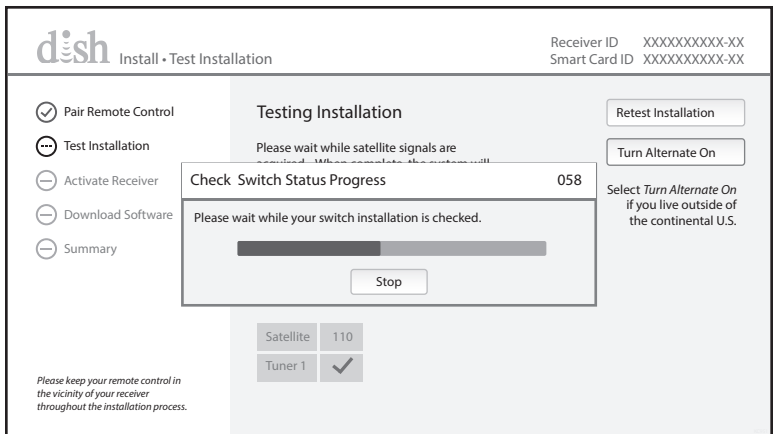

This screen will appear while the antenna scans for satellites.

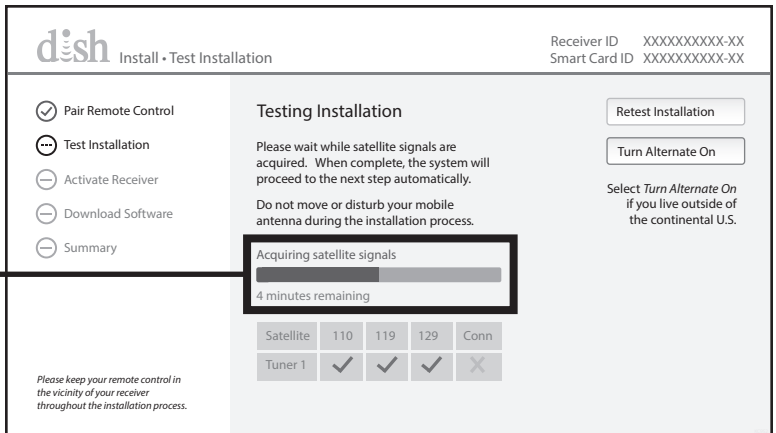

The satellite signals are being acquired. When complete, the system will proceed to the next step automatically.

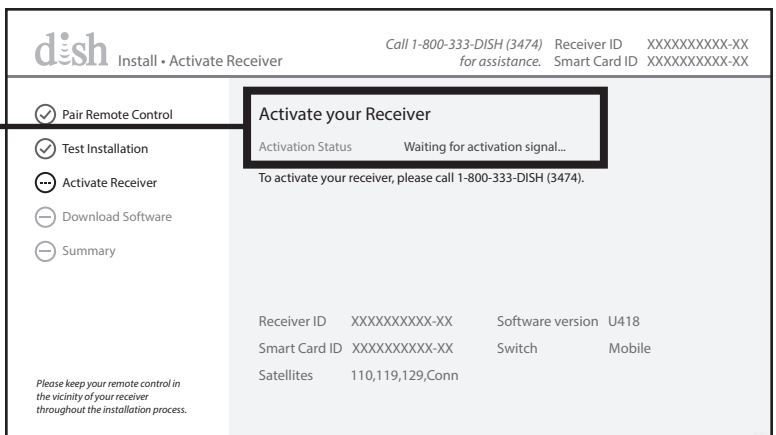

9. You are now ready to activate your receiver. Call a DISH mobile antenna specialist to activate your receiver.

1-800-963-DISH (3474)

After calling to activate your receiver, a software download will begin.

Do not disturb or unplug your receiver during this process!

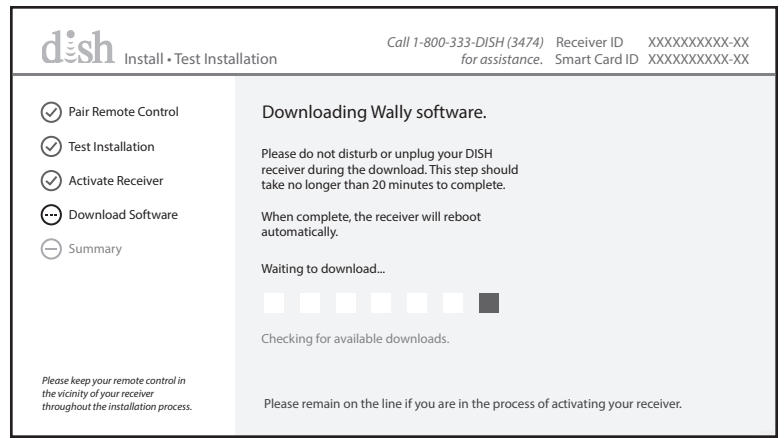

10. When the download is complete, the installation summary will appear.

Use the arrow buttons on your remote to highlight "Activate Receiver" and press **Select**.

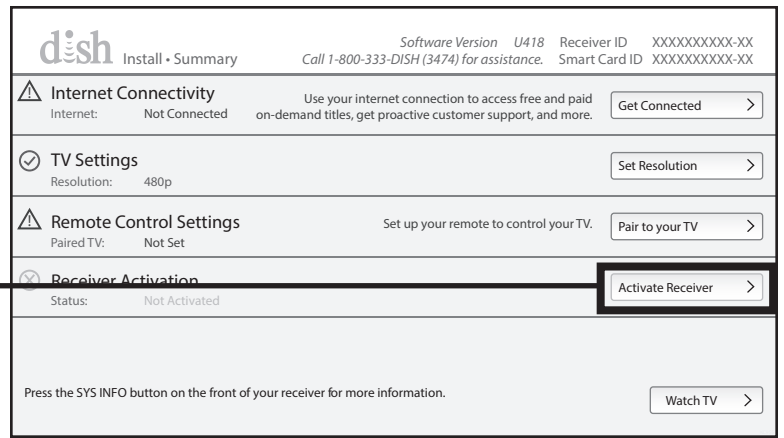

The receiver activates.

This may take a while. PLEASE BE PATIENT.

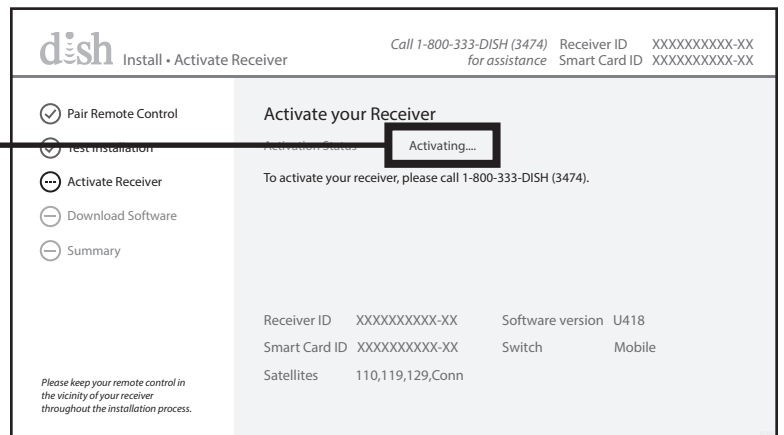

The installation summary screen confirms receiver activation.

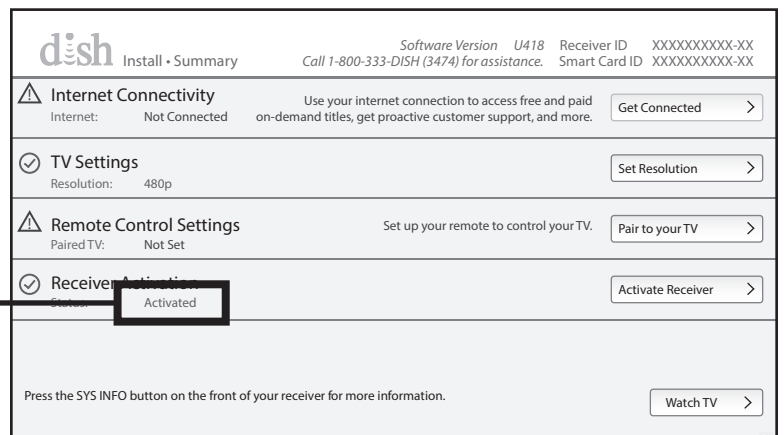

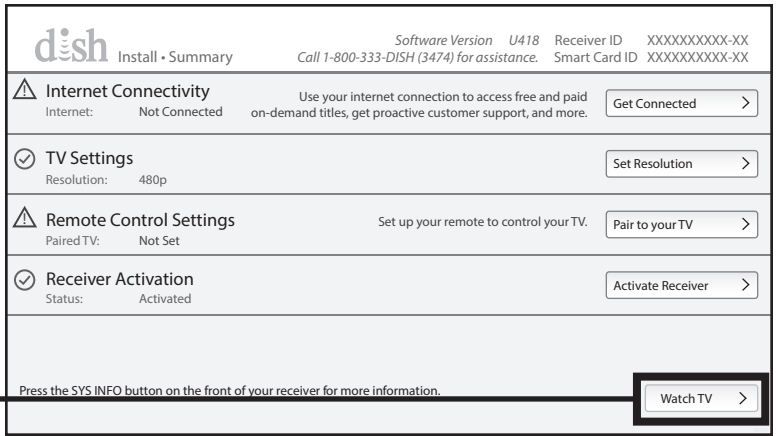

11. Use the arrow buttons on your remote to highlight “Watch TV” and press **Select**.

The receiver will acquire signal.

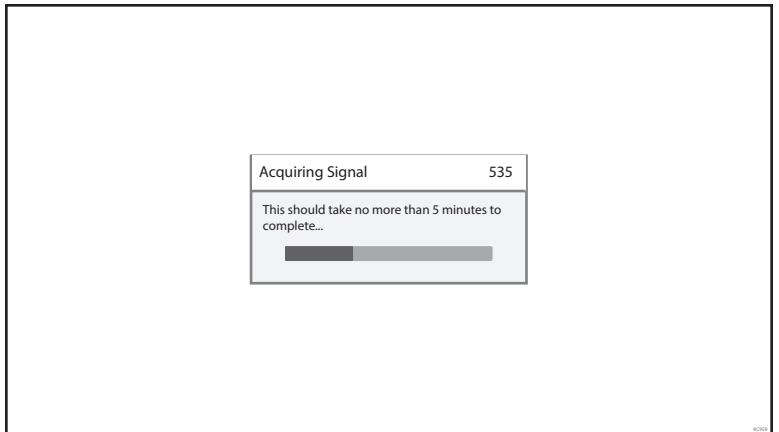

12. Watch TV!



NOTE: Your Wally should have downloaded its program guide already. Check and make sure the full guide is available. If it is not, you will need to reset the Wally for it to download the full guide.

If there is a software update available for your Wally, it will automatically download when you put your Wally in standby mode.

You can now use STANDARD OPERATION on page 12.

STANDARD OPERATION



IF YOUR RECEIVER IS NEW AND UNACTIVATED, MAKE SURE TO DO THE FIRST-TIME SETUP PROCEDURE ON PAGES 6-11 FIRST.



WHILE IN USE, DO NOT BLOCK THE DISH TAILGATER PRO'S LINE-OF-SIGHT TO THE SATELLITES IN THE SOUTHERN SKY AT ANY TIME!

SATELLITES IN SOUTHERN SKY

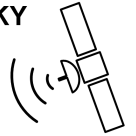

Point handle north to speed up scan time.

ANTENNA UNIT

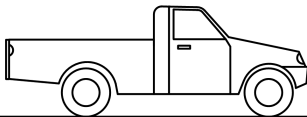

OBSTRUCTIONS

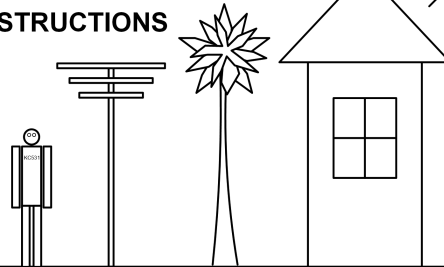

IMPORTANT!
If you move the antenna unit any time during or after the scan, you will have to repeat the scan.

NOTE: This manual shows graphics for a DISH Wally receiver. If you have a ViP model receiver, you can access the DISH Tailgater with ViP Receiver Owner's Manual by going to kingconnect.com/support. Click on "Owners Manuals" and choose the manual for DISH Tailgater with ViP receiver.

1. After connecting and turning on your equipment as instructed on pages 4-5, the Wally Startup screens will appear (this may take several minutes).

NOTE: If the Wally Standby screen appears, press any button on your remote to continue.

WallyTM

Starting Up...

IMPORTANT!

Your TV screen may look different from what is shown in this manual. Screen information may vary depending on choices you make.

For best results,
follow the on-screen instructions.

Starting up...

9999

- After the Wally starts up, the Mobile Antenna Setup screen will appear.

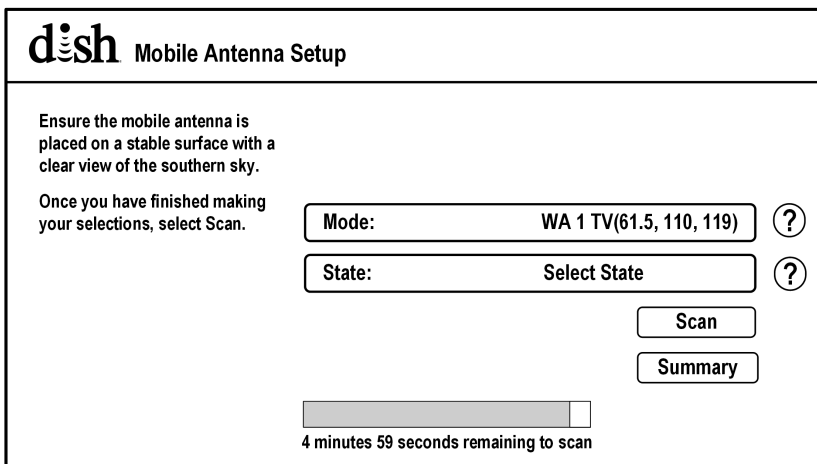

NOTE FOR STEP 3:

The 110, 119, 129 trio will work for most of the country.

The antenna unit may have trouble locking onto the 129 when in the northeastern United States (you can use the Test Installation Screen after a scan to check this).

If the antenna unit does not lock onto the 129, choose the 61.5, 110, 119 trio.

Any programming from the 129 will not be available when using the 61.5, 110, 119 trio.

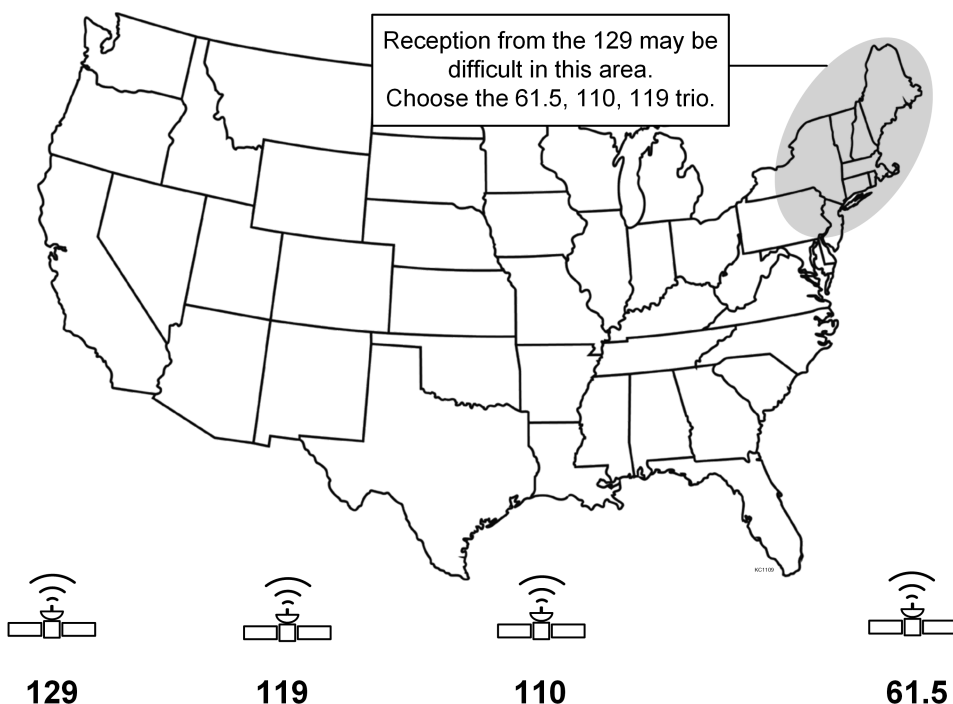

STANDARD OPERATION

- Use the arrow buttons on your remote to highlight the mode menu. Press **Select** on your remote to open the mode menu.

Use the arrow buttons on your remote to highlight the mode you wish to select.

Press **Select** on your remote.

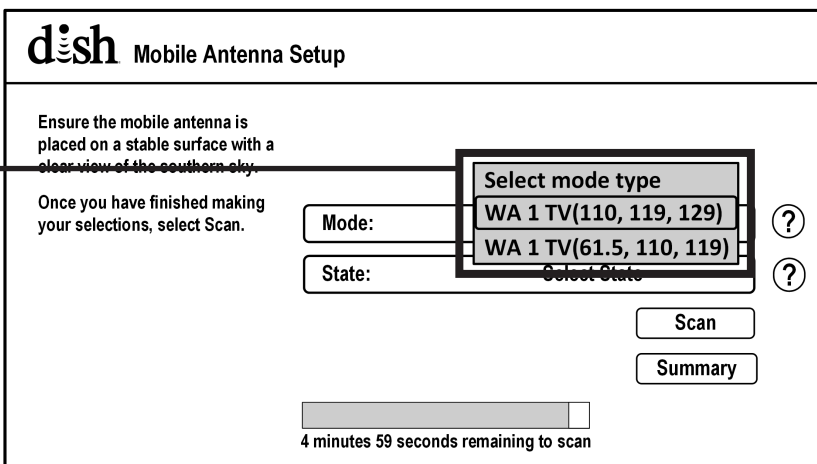

4. Use the arrow buttons on your remote to highlight the state menu. Press **Select** on your remote to open the state menu.

Use the arrow buttons on your remote to highlight the state you are currently in.

Press **Select** on your remote. (State selection will be saved.)

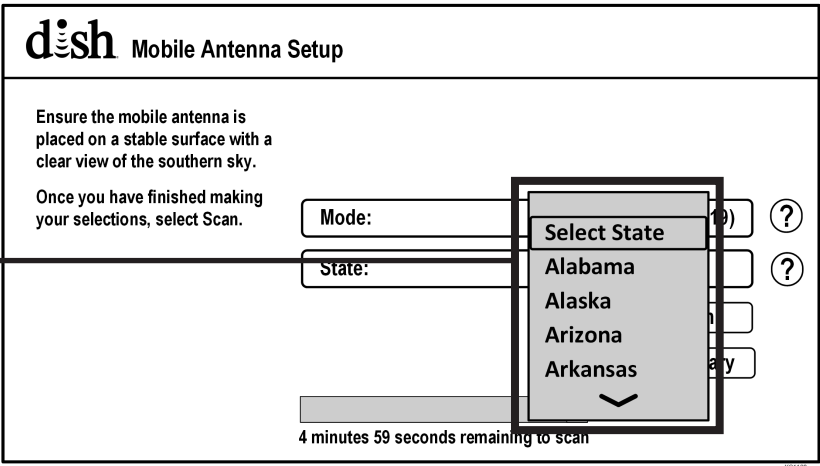

5. Use the arrow buttons on your remote to highlight "Scan."

Press **Select** on your remote.

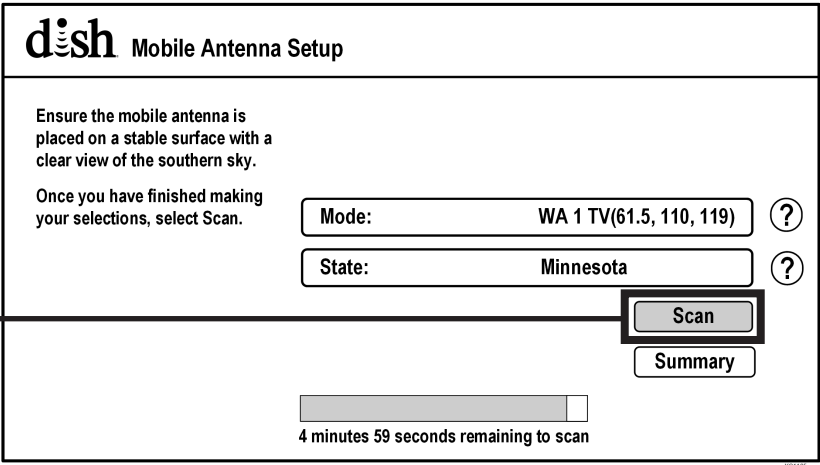

The scan will begin and may take up to several minutes to complete.

This screen will appear during the scan.

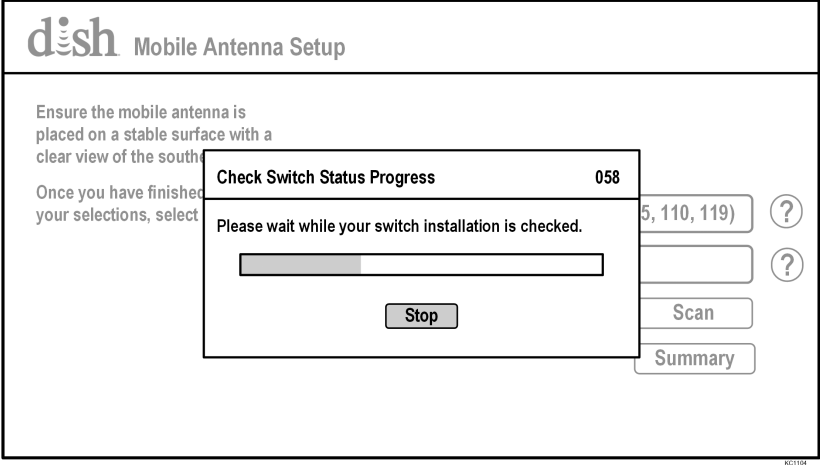

When the scan is complete, the Acquiring Signal screen will appear.

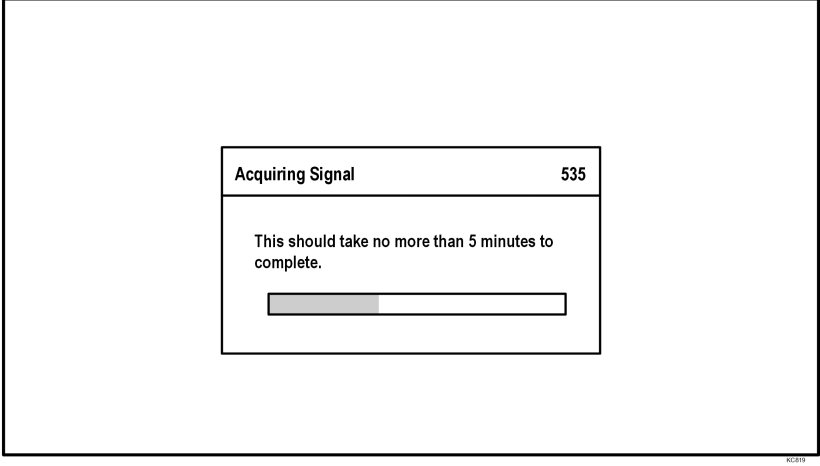

After your receiver has acquired the signal, the program guide will download. This may take up to 10 minutes to complete (potentially longer if an external hard drive is connected).

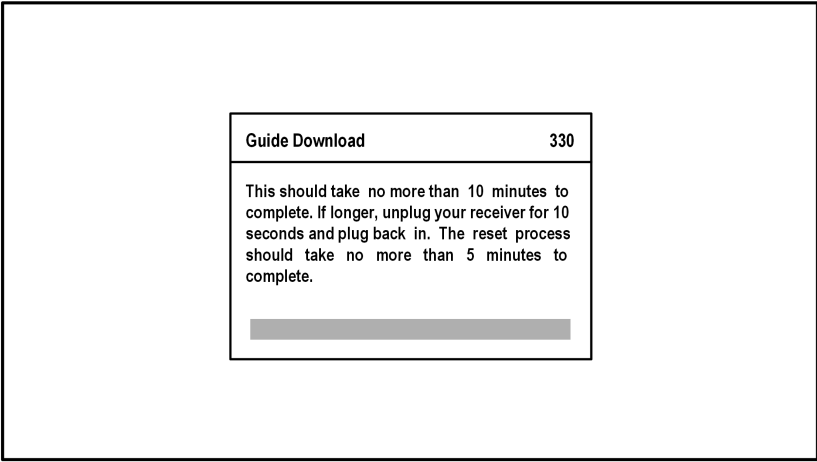

6. When the guide has downloaded, live TV will appear.

Enjoy!



OPERATING NOTES:

If you move the DISH Tailgater Pro while in use, or get a screen indicating complete signal loss, you will have to perform a new scan to restore programming by going to the Mobile Antenna Setup screen as follows:

Press the HOME button to return to the home page. Choose “Settings” and then “Diagnostics.” Choose “Dish 3” and then “Test Installation 5.” This will take you back to the Mobile Antenna Setup screen. Initiate a new scan.

When in the northeastern United States, television programming from the 129 satellite may not be available (see page 13).

If your system is inactive for an extended period of time, you may have to call DISH Customer Service at 1-800-333-DISH (3474) to reauthorize your receiver.



If your receiver has not been used for a while the 013 error message may appear. Call 1-800-333-DISH (3474) and follow the prompts to reauthorize your receiver. Note that if channel 101 appears, scroll channel up or down to make sure 013 error message does not appear.

You can view your programming when your receiver has been authorized and the guide has finished downloading.

SECOND RECEIVER OPERATION

IMPORTANT! If your second receiver is new and unactivated, you must first connect it to the MAIN port and do an initial setup as described in the New and Unactivated Receiver Section starting on page 6.

INITIAL SETUP FOR SECOND RECEIVER

1. Make sure your second receiver has been properly set up and activated (while connected to the MAIN port) as described in the New and Unactivated Receiver Section (page 6).
2. Connect your properly activated main receiver to the MAIN port. Run a scan to lock onto the satellites.
3. Connect the second receiver to the AUX port.
4. Run a check switch test on second receiver. When test is complete, save the results.

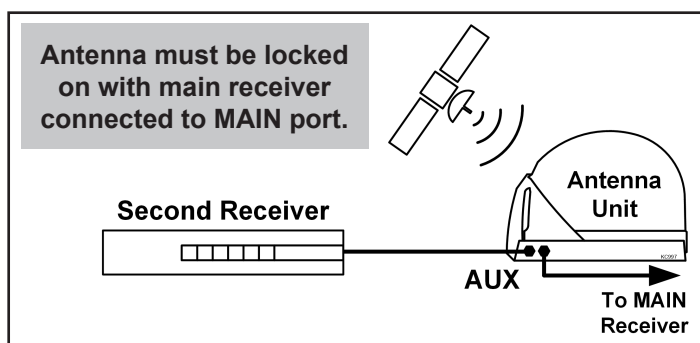

DOWNLOADING PROGRAMMING TO THE SECOND RECEIVER

5. After completing the check switch test, reset the second receiver by pressing the POWER button on the front panel for 10 seconds. The receiver will reboot and go into sleep mode (green light on front panel will be off). Press **Select** to wake it up.

The receiver will then download the program guide to show only the channels available on the current satellite as determined by the channel selected on the main receiver. Downloading the new program guide can take up to five minutes to complete.

The channels available on the second receiver are determined by the channel/satellite selected on the main receiver. For example, if you select a channel on the main receiver that is broadcast from the 119 satellite, then the second receiver will be able to view any channel broadcast from the 119 satellite.

If you switch channels on the main receiver to one that is broadcast from a different satellite, (for example, your channel was broadcast from satellite 119 but your new channel is broadcast from the 110), the antenna will automatically switch to the 110 satellite and programming will be lost on the second receiver until you either:

- Select a channel on the main receiver that is broadcast from the previous satellite (satellite 119 in this example).
- (or)
- Reset the second receiver by running another check switch test to download the program guide for the newly selected satellite (satellite 110 in this example).

NOTE: If you choose a channel on the main TV that causes the antenna to switch satellites, you may have to run a check switch on the second receiver.

This page intentionally left blank.

PROPER CARE OF YOUR EQUIPMENT

1. Always handle the DISH Tailgater Pro carefully. Do not drop the DISH Tailgater Pro. Avoid excessive shock or vibration to the DISH Tailgater Pro.
2. Use caution when carrying the DISH Tailgater Pro. Always carry the DISH Tailgater Pro by the handle.
3. Do not remove the cover of the DISH Tailgater Pro without authorization. Doing so will void the Limited Warranty.
4. Do not stack the DISH Tailgater Pro on top of or below other electronic devices as this can cause heat build-up or block the satellite signal from reaching the DISH Tailgater Pro.
5. Never power wash the DISH Tailgater Pro. Keep the enclosure clean from dirt, bugs, and other debris by hand washing with mild soap and water.
6. Do not coat or paint the DISH Tailgater Pro with any substance.

The DISH Tailgater Pro has been designed to be maintenance and trouble free. If not using the DISH Tailgater Pro for long periods of time, it is recommended that you set up the system on a quarterly basis (every three months) to keep all moving parts of the DISH Tailgater Pro in good working order.

If you have any comments or questions, please contact KING Customer Service at (952) 345-8147, or by email at help@kingconnect.com.

SECURITY

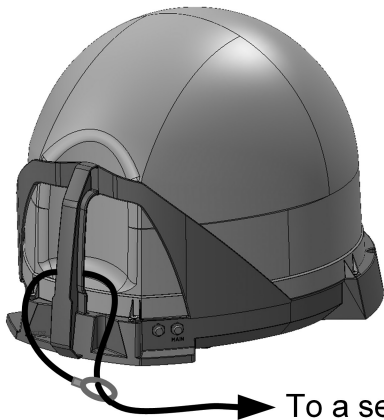

The DISH Tailgater Pro can be secured to an object by looping a cable thru the handle.

NOTE: The optional KING AL1000 Alarm is also available (see next page).

→ To a secure object

Cable sold separately.

ACCESSORIES (Sold separately - see the satellite antenna accessories page at kingconnect.com)

TR1000

Tripod Mount

Allows you to position your DISH Tailgater Pro almost anywhere for best line of sight to satellite. Keeps antenna off the ground away from moisture.

DISH Tailgater Pro not included.



CB1000

Carry Bag

DISH Tailgater Pro fits securely inside. Features include zippered cover, foam padding, carry handles and pockets for cables, receiver and remote.

DISH Tailgater Pro not included.



AL1000 Alarm



The KING AL1000 Alarm goes in-line between your powered receiver and the DISH Tailgater Pro.

It will sound an alarm if the coax is disconnected from the DISH Tailgater Pro.

(Not for use when a second TV and receiver are connected to AUX port.)

DISH Tailgater Pro not included.

MB500 Mounting Bracket

Mounting Bracket

Includes (2)
Hanger Brackets

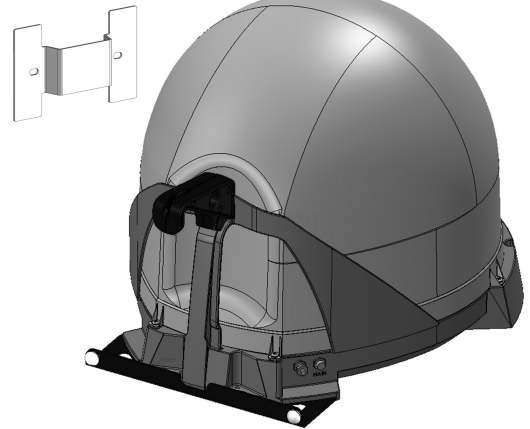

Allows hanging of antenna unit on vehicle window or included hanger bracket.

For stationary use only.
Vehicle must not be in motion while antenna unit is on window or hanger bracket.

DISH Tailgater Pro not included.

MB600 Removable Mounting Feet

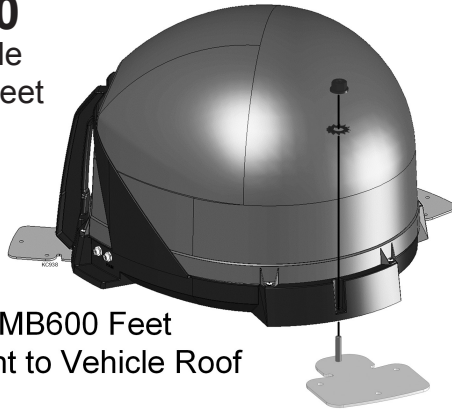

MB600 Feet
mount to Vehicle Roof

The MB600 removable mounting feet allow semipermanent mounting of your DISH Tailgater Pro on your vehicle roof.

DISH Tailgater Pro not included.

MB700 Quick Release Roof-Mount Kit

Allows you to easily use your DISH Tailgater Pro as either a roof-mounted or portable antenna.

DISH Tailgater Pro not included.

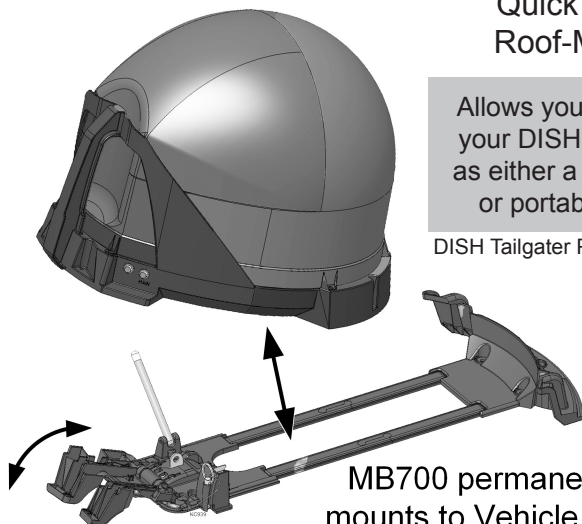

MB700 permanently
mounts to Vehicle Roof

MB160 Mounting Bracket

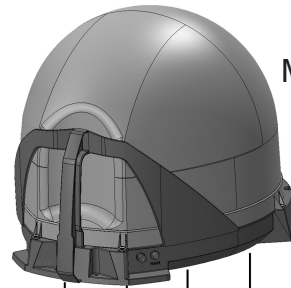

MB160 Mounts to
Back of Vehicle

The DISH Tailgater Pro is not compatible with the MB100 Mounting Bracket. Use of the MB100 will void warranty.

The use of any unauthorized mounting bracket will void warranty.

DISH Tailgater Pro not included.

ROOF INSTALLATION

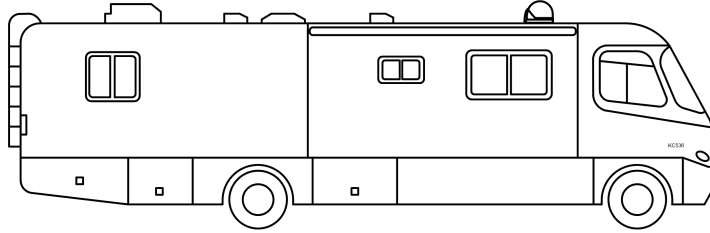

1. Make sure you have the following tools and materials before starting.



Drill

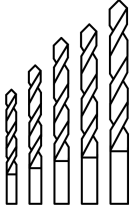

Drill Bit Set



7/16" Open-end Wrench
(for coax connections)



Roof-Compatible Sealant

Appropriate Fasteners to install all components and wiring
(to be determined and supplied by installer)



Optional Installation Accessories
(see page 19)

MB600 Mounting Feet: Allows you to semipermanently mount the antenna unit.

MB700 Roof-Mount Kit: Allows you to easily use the DISH Tailgater Pro as either a roof-mounted or portable antenna.

NOTE: Many RVs are prewired with RG-6 coax cable for satellite antennas. Contact the manufacturer of your RV or your local dealer to verify where this cable is located.

If prewired, run the existing coax cable from the prewired location in the roof to the antenna unit. When choosing the antenna unit location, make sure the prewiring will reach the antenna unit.

ANTENNA UNIT LOCATION (see illustration on next page)

2. Select an area on the roof for the antenna unit and the location where the wiring will enter the vehicle through the roof to the satellite receiver inside using the following criteria:
 - A shorter distance between the antenna unit and the satellite receiver is most desirable.
 - Make sure you have enough room to mount the antenna unit.
 - The antenna unit should be mounted on the center line of the vehicle, and not tilted more than 2 degrees in any direction.
 - There must be no “line of sight” obstructions. Air conditioning units, other antennas, and storage areas that are too close to the antenna unit may prevent the satellite signal from reaching the antenna unit.
 - Mount the antenna unit with the handle to rear of the vehicle.

ANTENNA UNIT LOCATION

| HEIGHT OF OBSTRUCTION | APPROXIMATE MINIMUM DISTANCE TO EDGE OF ANTENNA UNIT |
|-----------------------|--|
| 10" | 8" |
| 11" | 10" |
| 12" | 12" |
| 13" | 14" |
| 14" | 16" |
| 15" | 18" |
| 16" | 20" |

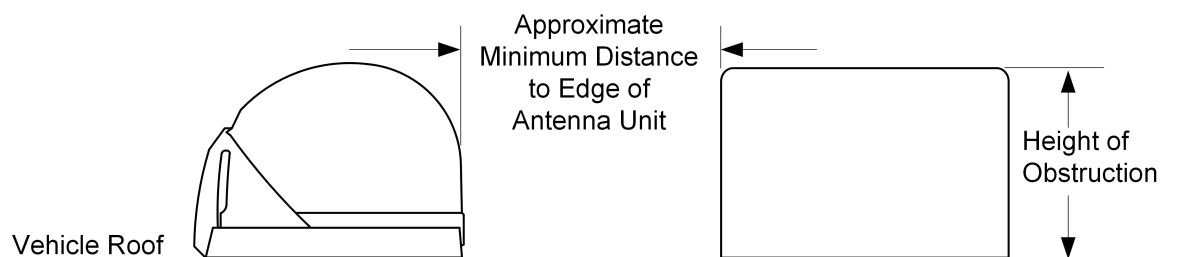

Do not mount antenna unit too close to obstructions.

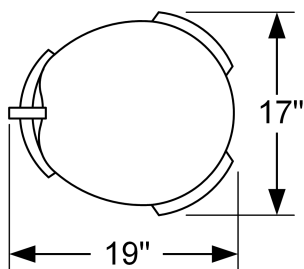

Choose a location with adequate space.

Mount antenna unit on center line of vehicle.

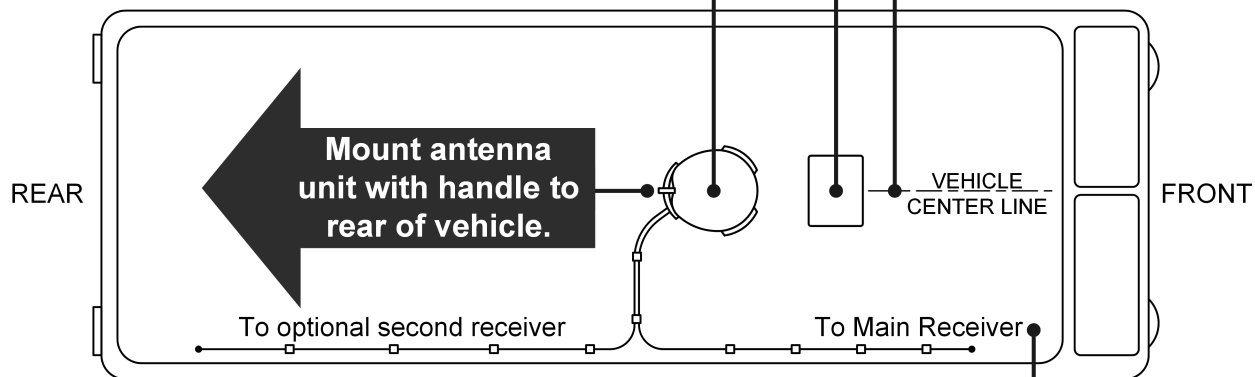

Try to install antenna unit as close as possible to main receiver to minimize coax length.

The installer is responsible for determining the most appropriate fasteners to secure the antenna unit to the roof. Depending on the roof material, fasteners such as lag screws, well nuts, sheet metal screws, toggle bolts and T anchors may be used, and should always be used in combination with a **roof-compatible sealant**.

IMPORTANT! The installer is responsible for weatherproofing all holes (except drain holes) with sealant.

3. If the rubber feet have been installed, remove them from the bottom of the unit.

DO NOT INSTALL UNIT ON ROOF WITH RUBBER FEET IN PLACE.

4. Apply **roof-compatible** sealant to roof around entire area where fasteners will penetrate the roof. Mount the antenna unit using the (4) mounting holes. After mounting unit, seal fastener heads with **roof-compatible** sealant.

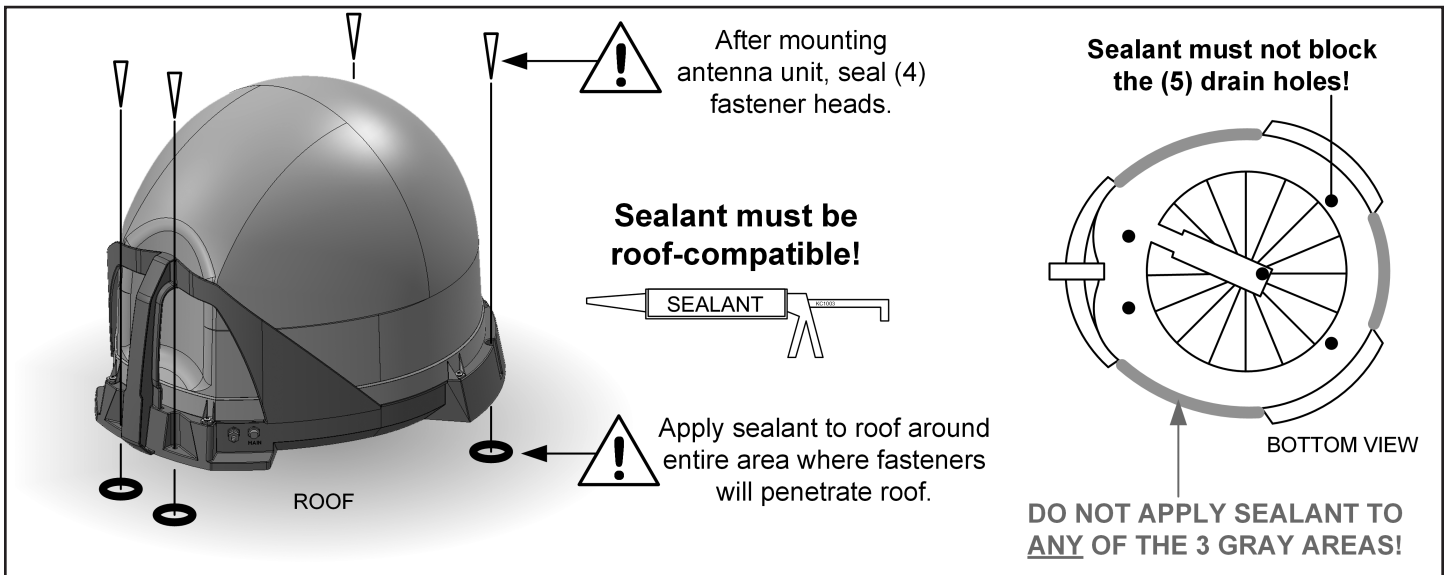
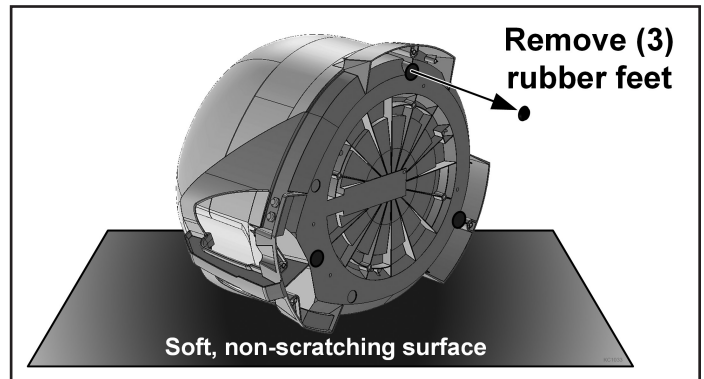

There are two coax ports on the back of the antenna unit. The one labeled "MAIN" **MUST** be connected to the main receiver in vehicle. The one labeled "AUX" can be used for an additional receiver if desired.

5. Connect one end of 50 foot coax cable to the MAIN port and tighten connection (see below). **DO NOT OVER-TIGHTEN.**

If using a second receiver, connect end of second coax (sold separately) to the AUX port. Tighten connection. **DO NOT OVER-TIGHTEN.**

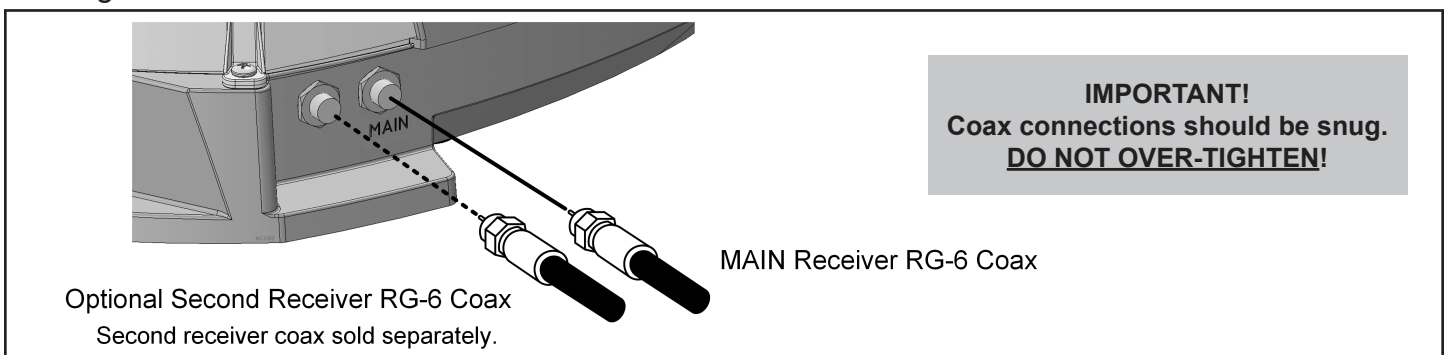

AVOID SHARP BENDS WHEN ROUTING COAX!

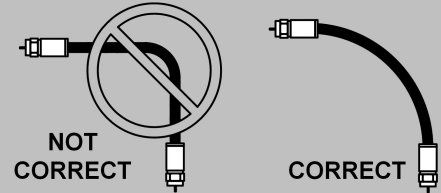

- Run coax from the antenna unit to the roof edge, then along edge to location where coax will be fed into the vehicle. If installing an optional second receiver, run second coax to location where it will enter the vehicle. Secure (both) coax to roof every 12-18 inches (see below).
- Drill 3/4" hole through the roof and into the cabinet where receiver is stored. Feed coax down through hole. Seal opening with roof-compatible sealant so that it is completely waterproof (inside and outside of the 3/4" hole). Repeat for second coax if present.

TYPICAL ROOF INSTALLATION – OVERHEAD VIEW

AVOID SHARP BENDS WHEN ROUTING COAX!

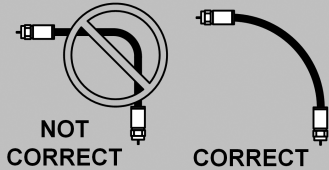

IMPORTANT!

Roof hole(s) for wiring must be sealed so they are completely waterproof.

Sealant must be roof-compatible.

The CE2000 Cable Entry Cover provides a watertight seal where cables penetrate the roof (see the satellite antenna accessories page at kingconnect.com for more information).

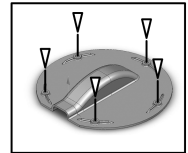

NO SHARP BENDS IN WIRING!

To Optional Second Receiver

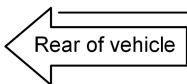

Rear of vehicle

Edge of Roof

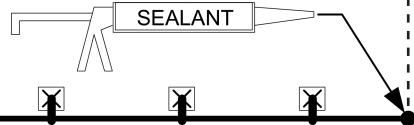

SEALANT

NO SHARP BENDS IN WIRING!

- Inside vehicle, connect coax cable(s) to the receiver(s).

IMPORTANT!

You can cut the coax to length but you must terminate the coax with Snap-n-Seal Connectors.

SNAP-N-SEAL® CONNECTOR

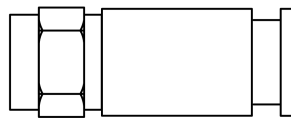

Thomas and Betts part # SNS 1P6

CRIMPER

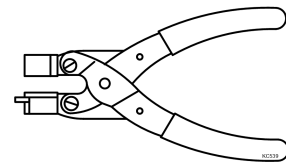

Thomas and Betts part # SNSUTL

Connector and crimper sold separately.

- Installation is complete! Go to the OPERATION Section and watch TV!

TROUBLESHOOTING

| Symptom/Message | Possible Cause | Troubleshooting |
|---|--|---|
| <p>"SmartCard Not Inserted" message (021) on startup.</p> | <p>SmartCard is not fully seated in Wally slot.</p> | <p>Your SmartCard is located on the left side of the Wally. Pull out the SmartCard and insert it back into the slot. Make sure the arrow on the SmartCard is facing up and is inserted first into the receiver. If there is not a SmartCard in your receiver please call 1-800-333-DISH.</p> |
| <p>My remote is not working.</p> | <p>Remote is in wrong mode.</p> | <p>If you think the remote is paired, but in the wrong mode, press the "SAT" button on the left side of the remote.</p> |
| | <p>Your batteries may need to be replaced.</p> | <p>Check to make sure the batteries are properly inserted in your remote. If "SAT" on the front top of the remote does not light up when you press the SAT button on the left side of the remote, replace the batteries.</p> |
| | <p>Your remote is not currently paired with your receiver.</p> | <p>To pair your remote, press the "SYS INFO" button on the front of the Wally and then press the "SAT" button on the left side of your remote.</p> |
| <p>Complete Signal Loss - 015A</p> | <p>Obstructions to the DISH Tailgater Pro's view of the southern sky, such as tree branches, severe rain, etc.</p> | <p>Make sure nothing is blocking the DISH Tailgater Pro's view of the southern sky, such as tree branches, severe rain, or other obstructions.</p> |
| | <p>Coax cable not connected properly between your Wally and the DISH Tailgater Pro.</p> | <p>Check that the coax cable between your Wally and the DISH Tailgater Pro is connected properly and hand-tightened.</p> |
| | <p>You have selected a local channel but are outside of its spot beam area.</p> | <p>First, verify you have reception by selecting a nationally broadcast channel (CNN, ESPN, etc.).</p> <p>Then call DISH at 1-800-333-DISH to have your locals switched to your current area.</p> |
| | <p>DISH Tailgater Pro has been moved.</p> | <p>If DISH Tailgater Pro has been moved, initiate a new scan.</p> |
| <p>Channel Signal Loss - 004</p> | <p>DISH Tailgater Pro has not tracked to the appropriate orbital slot upon channel change.</p> | <p>There may be an obstruction blocking signal from the newly chosen satellite.</p> <p>Verify there are no obstructions, or move DISH Tailgater Pro to have a better view of southern sky and initiate a new scan. Once your system has found its satellites, it may take a few minutes to download the electronic program guide and acquire signal before live TV appears.</p> |

| Symptom/Message | Possible Cause | Troubleshooting |
|-------------------------------------|---|--|
| All Satellites Not Found - 150 | Obstructions to the DISH Tailgater Pro's view of the southern sky, such as tree branches, severe rain, etc. | Make sure nothing is blocking the DISH Tailgater Pro's view of the southern sky, such as tree branches, severe rain, or other obstructions. |
| | Your physical location may be outside the footprint of the desired orbital slot. | Unplug the power cord of your receiver for 10 seconds and plug it back in. It may take up to 5 minutes for your receiver to power back on. |
| No Satellites Found - 151 | Obstructions to the DISH Tailgater Pro's view of the southern sky, such as tree branches, severe rain, etc. | Make sure nothing is blocking the DISH Tailgater Pro's view of the southern sky, such as tree branches, severe rain, or other obstructions. |
| | Coax cable not connected properly between your receiver and the DISH Tailgater Pro. | Check that the coax cable between your receiver and the DISH Tailgater Pro is connected properly and hand-tightened. Unplug the power cord of your receiver for 10 seconds and plug it back in. It may take up to 5 minutes for your receiver to power back on. |
| OTA Channel Signal Lost - 739 | The signal has been lost for this over-the-air channel. This can be due to relocation or realignment of the antenna. | Reposition antenna into optimal position to get clearest signal. May need to scan again for OTA channels. |
| | Possible obstruction of the signal. | Remove obstruction from signal path. |
| OTA Tuner Module Not Detected - 978 | An over-the-air (OTA) tuner module has been removed. | Reinstall OTA tuner module. When this is complete the Wally will request to be reset. Select YES to reset the Wally. |
| Local Channels Interrupted - 536 | | Call DISH at 1-800-333-DISH to have your locals switched to your current area. |
| Missing Channels. | The electronic program guide may not be set to "My Channels." | Press the GUIDE button on your remote twice to display the "Favorite Channels" menu. Select "None" or one of your favorite channels list. |
| | You may not have the orbital slots required to view the missing television programming. | Confirm that you subscribe to the missing channel by using dish.com/mychannels . |
| Low signal strength. | Because of the small size of the highly portable DISH Tailgater Pro, signal strength may not be as strong as with a fixed home antenna. | N/A |

| Symptom/Message | Possible Cause | Troubleshooting |
|--------------------------------|--|--|
| Unable to Access Feature - 024 | Feature not downloadable. | Keep receiver in standby for 1 hour. |
| Sporting Event Blackout - 744 | Blackout patterns are applied based on the physical address on your account. Events outside the area surrounding your physical address may not be available. | N/A |
| Outside of Viewing Area - 120 | You are outside of the viewing area of currently available channels. | Call DISH at 1-800-333-DISH to have your locals switched to your current area. |

MANUFACTURER'S LIMITED WARRANTY

Every new DISH Tailgater Pro Satellite System is thoroughly inspected and tested before leaving the factory, and is covered by the following limited warranty from the date of original purchase:

- Two-year parts warranty: The customer is not responsible for the cost of replacement parts if the original part is determined to be defective under the terms of the warranty. The customer is responsible for the cost of replacement parts after two years.
- One-year labor warranty: The customer is not responsible for labor costs to repair unit if unit falls under the terms of the warranty. The customer is responsible for all labor costs after one year.

Only KING and certified dealers may perform warranty evaluations and repairs. Depending upon the problem, KING may authorize a dealer to perform the necessary repairs. Any warranty labor outside of that performed at the factory is not covered unless 1) the product has been installed by an authorized dealer/installer or OEM manufacturer and 2) the dealer/installer receives prior authorization to perform the repair.

A certified dealer must not perform any repair without first contacting KING for a Service Order Number. KING will advise the dealer on how to proceed with any repairs.

Should any trouble develop during the warranty period, contact KING at (952) 345-8147. You must contact KING before the warranty period expires. The customer must supply proof of purchase (such as a dated sales receipt) when requesting warranty service. If the customer cannot supply proof of purchase, warranty period shall start 30 days after date of manufacture.

If it is determined that the unit needs to be returned to KING, customer must return COMPLETE product, freight prepaid, to:

KING, 11200 Hampshire Avenue South, Bloomington, MN 55438-2453.

If inspection shows the trouble is caused by defective workmanship or material, KING will repair (or at its option, replace) without charge.

When returning product, KING will supply an RMA number (Return Merchandise Authorization). This number must be clearly written on the box. Failure to clearly write RMA number on box will result in delays in processing claim. Along with product, the customer should include in the box: his/her name, address, daytime phone number, proof of purchase and description of the problem.

This warranty does not cover installation and external wiring, or remanufactured units. This warranty does not cover damage caused by the use of an accessory other than a KING accessory designed for the product. This warranty is not transferable from the original owner.

Due to the expanding and changing TV market, KING cannot be held responsible for changes made to satellite services. Software updates to address such issues are not covered under warranty. This warranty also does not apply where:

- The product has been abused, misused, improperly installed or improperly maintained.
- The product has been used with an accessory other than a KING accessory designed for the product.
- Repairs have been made or attempted by others that are not certified by KING to do such repairs.
- Repairs are required because of normal wear and tear.
- Alterations have been made to the product.
- The product or any associated component has been opened without authorization or disassembled to any degree.
- Damage has been caused by power washing.
- Circumstances beyond the control of KING cause the product to no longer operate correctly.
- Customer is not the original owner.

In no event shall KING be liable for any indirect, incidental, or consequential damages from the sale or use of the product. This disclaimer applies both during and after the term of this warranty.

KING disclaims liability for any implied warranties, including implied warranties of "merchantability" and "fitness for a specific purpose," after the term of this warranty.

This warranty gives you specific legal rights, and you may also have other rights, which vary from state to state. Some states do not allow the exclusion or limitation of incidental or consequential damages, so the above limitation or exclusion may not apply to you. Some states do not allow limitations on how long an implied warranty lasts, so the above limitation may not apply to you.

FCC GUIDELINES

This equipment has been tested and found to comply with the limits for a Class B digital device, pursuant to part 15 of the FCC Rules. These limits are designed to provide reasonable protection against harmful interference in a residential installation. This equipment generates, uses and can radiate radio frequency energy and, if not installed and used in accordance with the instructions, may cause harmful interference to radio communications. However, there is no guarantee that interference will not occur in a particular installation. If this equipment does cause harmful interference to radio or television reception, which can be determined by turning the equipment off and on, the user is encouraged to try to correct the interference by one or more of the following measures:

- Reorient or relocate the receiving antenna.
- Increase the separation between the equipment and the receiver.
- Connect the equipment into an outlet on a circuit different from that to which the receiver is connected.
- Consult the dealer or an experienced radio/TV technician for help.

dish || **tailgater**^{PRO}

To subscribe to programming or for assistance with using the DISH Tailgater Pro,
call 1-800-963-DISH (3474).

dishTM
outdoors