

For Service Assistance
Phone Toll Free 1-800-433-0708



Pro 30 Diesel Caddy

Model FC-P30-UL-D
Operator's Manual



Contents	Page
Safety & Warning Instructions	2
General Product Description	3
Assembly	3
Operation	4
Storage	4
Product Specifications	4
Replacement Parts & Accessories	5
Troubleshooting	6
Notes	7



JohnDow Industries, Inc.
151 Snyder Ave.
Barberton, OH 44203

REV 03/2019

TROUBLESHOOTING

CONDITION	POSSIBLE CAUSE	SOLUTION
Pump is hard to turn or poor flow	Filter is incorrect size for type of fuel	Replace with correct size filter 1 micron for E85. 10 micron for gasoline, 30 micron for diesel/kerosene
	Filter is clogged	Replace filter
	Inside of pump is dry or rusted from extended periods of non-use	Remove pump out hose by loosening the 90° elbow swivel fitting on top of pump. Spray WD-40 or other light oil into the pump out port. At the same time, turn handle in the opposite direction of the arrow to lubricate the pump. Must turn opposite direction of arrow to prevent pumping fuel from tank.
Pump is difficult to prime	Hose not submerged in fuel when trying to prime	Check hose and reposition hose in vehicle fuel tank
	Loose filter	Inspect and tighten
	Leak at fittings or pump mount	Check fittings and tighten as required.
	Leak in hose fittings	Check fittings and tighten
	Damaged, kinked, or cracked hose	Replace with hose assembly
	Vane sticking	Check vanes for contamination
	Excessive vane wear	Check vanes for excessive wear and replace
Fuel level gauge does not work	Float positioned diagonally across tank	Remove red plastic nut and indicator cap. Remove float mechanism and position so that float is position across tank. Replace cap and nut.
Ground wire is damaged or will not clamp	Damaged	Replace

GENERAL PRODUCT DESCRIPTION

The Gas Caddy is designed and approved to safely transfer fuel to and from a vehicle. It may be used to safely store fuel during vehicle service. It is approved for use with unleaded gasoline, diesel, kerosene, and E85 (ethanol) fuels.

The direction of flow is controlled by a 4-way valve to assure that fuel is filtered in both directions. **Caution: Turning the pump in the opposite direction will pump the fuel, but this will cause contaminants inside the filter to be introduced into the fuel stream. Always use the valve to control the direction of flow.**

The FC-P30 comes standard with a 10 micron filter for use with gasoline. Other filters are available for other fuels. Select the correct filter for the intended application. Proper filter selection is critical to achieving maximum pumping efficiency and to properly remove contaminants from the fuel.

Refer to the table shown in REPLACEMENT PARTS AND ACCESSORIES if you intend to pump different fuels.

Fuel Type	Filter Type
Unleaded Gasoline	10 micron
Diesel and Kerosene	30 micron
E85 Ethanol	1 micron

ASSEMBLY

Tools and Supplies (not included):

- TPE tape
- 1-1/2 inch open end wrench
- 1-1/16 inch open end wrench
- 1-1/4 inch open end wrench.

1. Wrap 2 inch NPT thread on fill tube 4-6 wraps with PTFE tape wrapping clockwise.
2. Assemble pump "A" onto tank by threading the "IN" side the pump onto the 3/4 close nipple. Hold the manifold with a 1-1/2 inch adjustable wrench to prevent turning. Turn pump until threads tighten with the final turn positioning the pump.
3. Position the handle to the left side of the tank as shown in Figure 1.
4. Assemble the pressure hose "B" to the 90° swivel fitting on top of the pump and to the 90° swivel fitting on the filter support. Place a 1-1/16 inch open end wrench on the hose and tighten the swivel using a 1-1/14 inch open end wrench. Tighten securely to prevent leaks. Note: when tight the swivel will not rotate.
5. Assemble the discharge hose "C" by threading the 3/4 NPT fitting into 90° fitting located on the front of the valve assembly. Place a 1-1/16 inch wrench on the hose and tighten. Tighten with wrench.
6. Coil and hang the discharge hose on the hose hanger bracket on the side of the tank.
7. Thread the 2 inch fill pipe and cap assembly onto the fitting in the center of the tank. Tighten snugly by hand until secure.

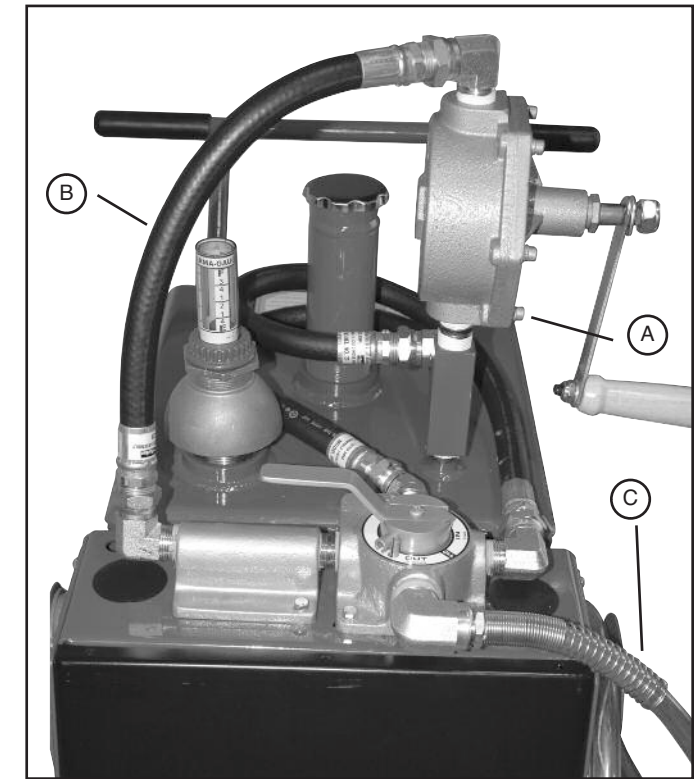

Fig. 1

10. Remove tape from top of fuel gauge and install plastic indicator cap and plastic nut onto float assembly. Align indicator mark to point diagonally across tank so that float is free to move full range. Tighten nut by hand to secure cap and fuel gage.

OPERATION

PUMPING FROM VEHICLE TO GAS CADDY

1. Position the Gas Caddy near the vehicle and lock the front casters brakes.
2. Attach the ground wire clamp to the vehicle to a known ground surface.
3. Place the hose inside the fill pipe of the vehicle fuel tank.
4. Align valve handle so that the point is to the "IN" to tank position. See figure 2.
5. Turn pump in the direction shown on the pump. Turn briskly until pump primes and fluid is visibly flowing in the hose.
6. Continue to turn the pump handle to maintain flow to the Gas Caddy.
7. Stop turning the handle when the desired amount has been pumped.
8. Uncoil and raise the hose and turn the handle 4-8 turns to return any remaining fuel in the system to the tank.
9. Coil and hang the hose on the hanger bracket.
10. Turn valve to the "OFF" position.

PUMPING FROM GAS CADDY TO VEHICLE

1. Position the Gas Caddy near the vehicle and lock the front casters brakes.
2. Attach the ground wire clamp to the vehicle to a known ground surface.
3. Place the hose inside the fill pipe of the vehicle fuel tank.
4. Align valve handle so that the point is position to the "OUT" to vehicle position. (See Fig. 3)
5. Turn pump in direction shown on the pump. Turn briskly until pump primes and fluid is visibility flowing in the hose.
6. Continue to turn the pump handle to maintain flow to the vehicle.
7. Stop turning the handle when the desired amount has been pumped.
8. Turn the valve to the "IN" to tank position.
9. Uncoil and raise the hose and turn the handle 4-8 turns to return any remaining fuel in the system to the tank.
10. Coil and hang the hose on the hanger bracket.
11. Turn valve to the "OFF" position.

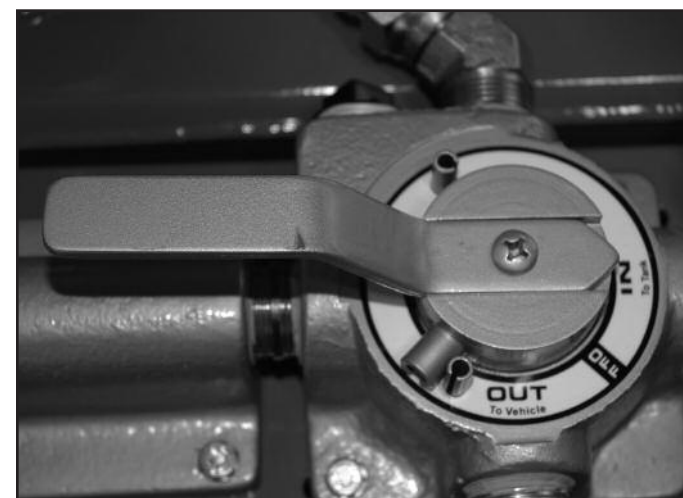

Fig. 2

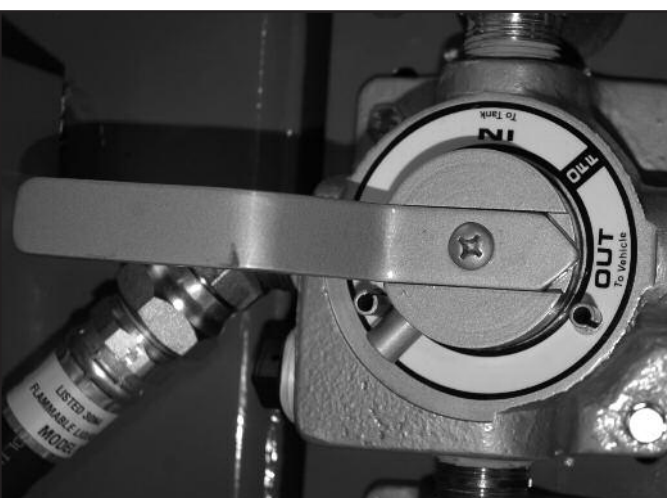

Fig. 3

STORAGE

1. Always place the valve in the "OFF" position when not in use.
2. Wrap and store the hose on the provided hose wrap bracket.
3. Wrap and store the ground wire on the provided wire wrap bracket.
4. Locate the park the Gas Caddy on a flat level surface, away from any potential ignition sources, away from any potential hazards that may impact or damage the Gas Caddy.
5. Lock the wheel brakes.
6. Be certain that the fuel gage vent dome, indicator cap, fill tube and fill tube cap are all present and secure. Replace any missing parts immediately.
7. Do not turn the pump handle when not in use as this may accidentally dispense fuel.

PRODUCT SPECIFICATIONS

Weight (empty):	154 lbs (69.5 kg)
Capacity:	30 gal (114 L)
Length:	31.25" (88.9 cm)
Width:	25.00" (63.5 cm)
Height:	46.00" (117.0 cm)
Approx. Flow:	5 gpm (19 L pm) @ 110 Rev/min

Replacement Parts & Accessories

REPLACEMENT PARTS:

Item	Description	Qty	Part No.
1	Tank	1	_____
2	Handle	1	30GC-02C
3	Cover	1	30GC-49-UL
4	Wheel (10")	2	30GC-06-UL
5	Caster (5")	2	30GC-48
6	Fuel Gage (cap/nut)	1	30GC-FGK
7	Fuel Gage (complete)	1	FC-P30-FG
8	Vent	1	30GC-08-VENT
9	Fill Tube	1	30GC-09-01
10	Fill Cap	1	30GC-09-02
11	Hose Assembly	1	80-593-NI
12	Ground Strap	1	80-572
13	Valve/Filter Support Asm.	1	30GC-30/31
14	Manifold	1	30GC-22A
15	Hose Kit (3 Hoses)	1	FC-P30-HK
16	Rotary Pump	1	JDI-35-UL
17	Contents Decal Set	1	FC-CON
18	Hose Bracket	1	30GC-46
19	Ground Wire Bracket	1	30GC-47

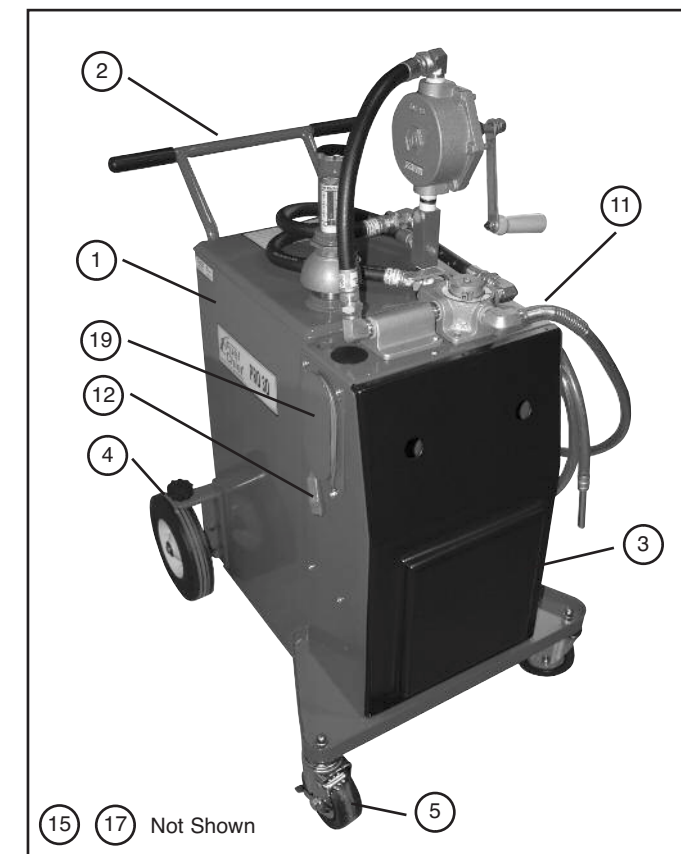
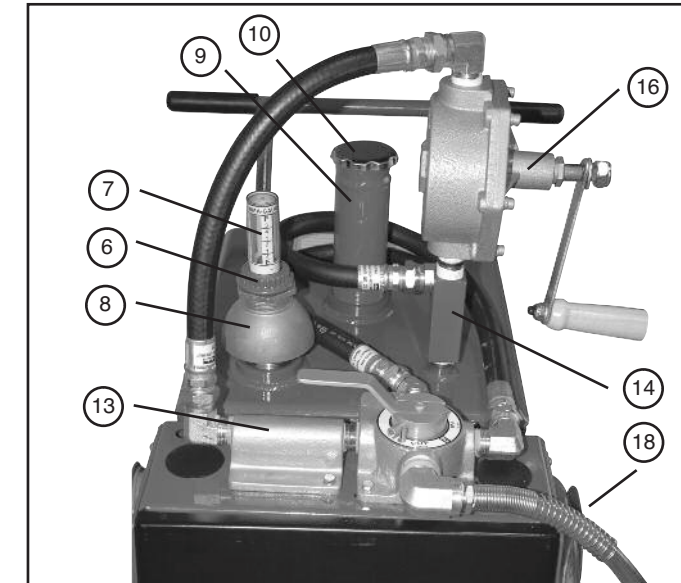

REPLACEMENT FILTERS

Fuel Type	Filter Type	Part No.
Unleaded Gasoline	10 micron	10M-FF
Diesel/Kerosene	30 micron	30M-FF
E85 Ethanol	1 micron	1M-FF

Note: Coat the O-ring seal with oil or grease before assembly. Hand tighten by turning approximately 1/2 turn after rubber seal contacts the filter support. Do not over-tighten.