

PowerLuber grease gun 20 v (lithium ion)

1886, 1886E, 1888, series "A", base model 1890 original instructions

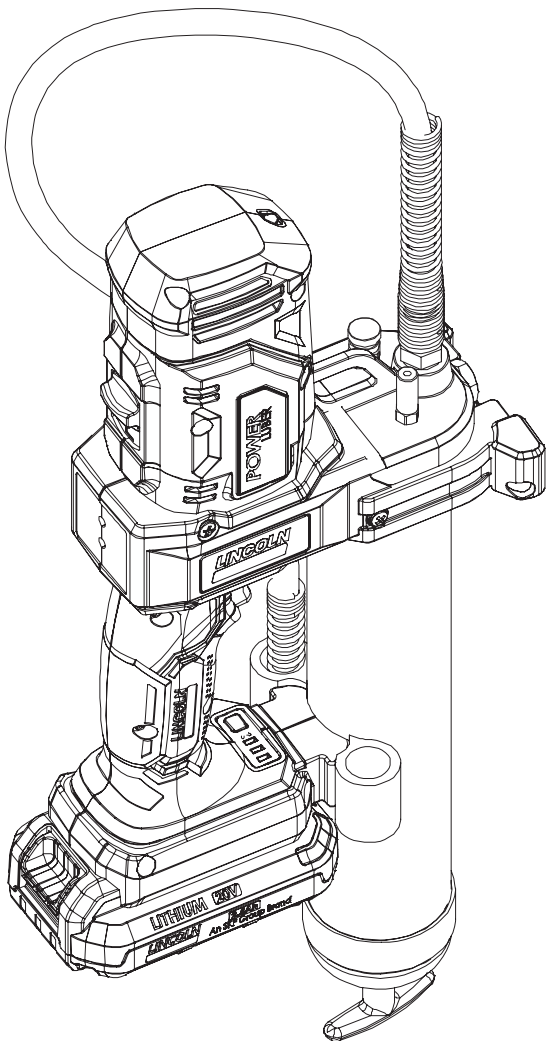

Date of issue	August 2019
Form number	400303
Version	1

Contents

Explanation of signal words	
for safety	3
Intended use	4
Safety instructions	4
General power tool safety warnings	4
Work area safety	4
Electrical safety	4
Personal safety	4
Power tool use and care	5
Battery tool use and care	5
Service	5
Safety of others	5
Specific safety	5
Residual risks	6
Vibration	6
Labels on battery charger	6
Maintenance	6
Protect environment	7
Safety instructions for battery	
and charger	7
Read all instructions	7
Batteries	7
Charger	8
Electrical safety	8
Tool use and care	9
Specifications	9
Description	10
Inspection	10
Operation	10
LED	10
Light sequence	10
Change L or H mode	11
Replace grease cartridge or refill tube	12
Priming instructions	12
Install grease cartridge	12
Fill gun from bulk container	12
Fill gun with filler pump	13
Expel air pockets (air purging)	13
Charger operation	14
Charging battery pack	14
Charging procedure	14
Important charging notices	14
Exploded views	15
Parts list	17
Troubleshooting	18
Declaration of Conformity	19
Warranty	20

Explanation of signal words for safety

NOTE

Emphasizes useful hints and recommendations as well as information to prevent property damage and ensure efficient trouble-free operation.

⚠ CAUTION

Indicates a dangerous situation that may lead to light personal injury if precautionary measures are ignored.

⚠ WARNING

Indicates a dangerous situation that may lead to death or serious injury if precautionary measures are ignored.

⚠ DANGER

Indicates a dangerous situation that will lead to death or serious injury if precautionary measures are ignored.

Intended use

This PowerLuber was exclusively designed to pump and dispense lubricant using 20 V battery power. Do not exceed maximum specification ratings.

⚠ WARNING



Read all safety warnings, instructions, illustrations and specifications provided with this power tool. Failure

to follow all instructions listed below may result in electric shock, fire and/or serious injury.

Safety instructions

General power tool safety warnings

Save all warnings and instructions for future reference. The term "power tool" in warnings refers to mains-operated (corded) power tool or battery-operated (cordless) power tool.

1 Work area safety

1.1 Keep work area clean and well lit.

Cluttered or dark areas invite accidents.

1.2 Do not operate power tools in explosive atmospheres, such as in presence of flammable liquids, gases or dust.

Power tools create sparks which may ignite the dust or fumes.

1.3 Keep children and bystanders away while operating power tool

Distractions can cause loss of control.

2 Electrical safety

2.1 Power tool plugs must match the outlet. Never modify plug in any way. Do not use any adapter plugs with earthed (grounded) power tools.

Unmodified plugs and matching outlets will reduce risk of electric shock.

2.2 Avoid body contact with earthed or grounded surfaces such as pipes, radiators, ranges and refrigerators.

There is an increased risk of electric shock if your body is earthed or grounded.

2.3 Do not expose power tools to rain or wet conditions.

Water entering a power tool will increase the risk of electric shock.

2.4 Do not abuse the cord. Never use cord for carrying, pulling or unplugging the power tool. Keep cord away from heat, oil, sharp edges or moving parts.

Damaged or entangled cords increase the risk of electric shock.

2.5 When operating a power tool outdoors, use an extension cord suitable for outdoor use.

Use of cord suitable for outdoor use reduces risk of electric shock.

2.6 If operating a power tool in a damp location is unavoidable, use a residual current device (RCD) protected supply.

Use of an RCD

reduces the risk of electric shock.

NOTE The term "residual current device (RCD)" can be replaced by the term "ground fault circuit interrupter (GFCI)" or "earth leakage circuit breaker (ELCB)".

3 Personal safety

3.1 Stay alert, watch what you are doing and use common sense when operating a power tool. Do not use a power tool while you are tired or under the influence of drugs, alcohol or medication.

A moment of inattention while operating power tools may result in serious personal injury.

3.2 Use personal protective equipment. Always wear eye protection.

Protective equipment such as a dust mask, non-skid safety shoes, hard hat or hearing protection used for appropriate conditions will reduce personal injuries.

3.3 Prevent unintentional starting. Ensure the switch is in the off-position before connecting to power source and/or battery pack, picking up or carrying the tool.

Carrying power tools with your finger on the switch or energising power tools that have the switch on invites accidents.

3.4 Remove any adjusting key or wrench before turning the power tool on.

A wrench or a key left attached to a rotating part of power tool may result in personal injury.

3.5 Do not overreach. Keep proper footing and balance at all times.

This enables better control of the power tool in unexpected situations

3.6 Dress properly. Do not wear loose clothing or jewellery. Keep your hair and clothing away from moving parts.

Loose clothes, jewellery or long hair can be caught in moving parts.

3.7 If devices are provided for the connection of dust extraction and collection facilities, ensure these are connected and properly used.

Use of dust collection can reduce dust-related hazards

3.8 Do not let familiarity gained from frequent use of tools allow you to become complacent and ignore tool safety principles.

A careless action can cause severe injury within a fraction of a second.

4 Power tool use and care

- 4.1 Do not force the power tool. Use correct power tool for your application.** The correct power tool will do the job better and safer at the rate for which it was designed.
- 4.2 Do not use the power tool if the switch does not turn it on and off.** Any power tool that cannot be controlled with the switch is dangerous and must be repaired.
- 4.3 Disconnect the plug from the power source and/or remove the battery pack, if detachable, from the power tool before making any adjustments, changing accessories, or storing power tools.** Such preventive safety measures reduce the risk of starting the power tool accidentally.
- 4.4 Store idle power tools out of the reach of children and do not allow persons unfamiliar with power tool or these instructions to operate the power tool.** Power tools are dangerous in the hands of untrained users.
- 4.5 Maintain power tools and accessories. Check for misalignment or binding of moving parts, breakage of parts and any other condition that may affect power tool's operation. If damaged, have the power tool repaired before use.** Many accidents are caused by poorly maintained power tools.
- 4.6 Keep cutting tools sharp and clean.** Properly maintained cutting tools with sharp cutting edges are less likely to bind and are easier to control.
- 4.7 Use the power tool, accessories and tool bits etc. in accordance with these instructions, taking into account the working conditions and the work to be performed.** Use of the power tool for operations different from those intended could result in a hazardous situation.
- 4.8 Keep handles and grasping surfaces dry, clean and free from oil and grease.** Slippery handles and grasping surfaces do not allow for safe handling and control of the tool in unexpected situations.

5 Battery tool use and care

- 5.1 Recharge only with the battery charger specified by the manufacturer.** A charger that is suitable for one type of battery pack may create a risk of fire when used with another battery pack.
- 5.2 Use power tools only with specifically designated battery packs.** Use of any other battery packs may create a risk of injury and fire.
- 5.3 When battery pack is not in use, keep it away from other metal objects, like paper clips, coins, keys, nails, screws or other small metal objects, that can make a connection from one terminal to another.** Shorting battery terminals together may cause burns or fire.
- 5.4 Under abusive conditions, liquid may be ejected from the battery; avoid contact. If contact accidentally occurs, flush with water. If liquid contacts eyes, additionally seek medical help.** Liquid ejected from the battery may cause irritation or burns.
- 5.5 Do not use a battery pack or tool that is damaged or modified.** Damaged or modified batteries may exhibit unpredictable behaviour resulting in fire, explosion or risk of injury.
- 5.6 Do not expose a battery pack or tool to fire or excessive temperature.** Exposure to fire or temperature above 130 °C may cause explosion. NOTE The temperature "130 °C" may be replaced by the temperature "265 °F".
- 5.7 Follow all charging instructions and do not charge the battery pack or tool outside the temperature range specified in the instructions.** Charging improperly or at temperatures outside the specified range may damage the battery and increase the risk of fire.

6 Service

- 6.1 Have your power tool serviced by a qualified repair person using only identical replacement parts.** This will ensure that the safety of the power tool is maintained.

6.2 Never service damaged battery

packs. Service of battery packs should only be performed by the manufacturer or authorized service providers.

Safety of others

This appliance is not intended for use by persons with reduced physical, sensory or mental capabilities, or lack of experience and knowledge, unless they have been given supervision or instruction concerning use of the appliance by a person responsible for their safety.

Children should be supervised to ensure that they do not play with the appliance.

Specific safety

Always wear eye protection. The PowerLuber can generate up to 10 000 psi (689 bar). Use only Lincoln 1218, 1224, 1230, 1236 or 1248HP outlet whip hoses. Grease injection injuries are a very serious injury. Hold hose only in area of spring guard. Avoid accidental starting. Be sure switch is not depressed when inserting battery pack. Replace the hose at the first sign of wear, kink or damage to the outside jacket.

Do not bend hose so that it becomes kinked.

Do not overreach. Keep proper footing and balance at all times. Proper footing and balance enable better control of the tool in unexpected situations.

Use safety equipment. Always wear eye protection.

Dust mask, non-skid safety shoes, hard hat or hearing protection must be used for appropriate conditions.

The gun uses lubricants, that may be flammable and poisonous if ingested. Do not use gun near open flame or other fire hazards.

Greases are often marketed as high temperature because it must maintain their lubricating properties in hot areas, but the lubricants may be flammable if the temperature is too high. Please read all warnings on lubricants before using this gun. Do not use flammable greases with this grease gun.

⚠ WARNING

Do not use any hose not approved by Lincoln. Extreme pressure may cause nozzle extension or whip hose to burst.

Replace hose at first sign of wear, kinks, or damage to outside jacket.

Follow whip hose instructions and warnings.

Failure to comply may result in death or serious injury.

⚠ WARNING

Grease gun can develop high pressure up to 10 000 psi (689 bar). Use safety glasses and gloves for protection during operation. Keep hands clear of exposed rubber portion of hose.

Failure to comply may result in death or serious injury.

Residual risks

Additional residual risks may arise when using tool that may not be included in enclosed safety warnings. These risks can arise from misuse, prolonged use, etc.

Even with application of relevant safety regulations and implementation of safety devices, certain residual risks cannot be avoided. These include:

- Injuries caused by touching any rotating/moving parts.
- Injuries caused when changing any parts, blades or accessories.
- Injuries caused by prolonged use of tool. When using any tool for prolonged periods ensure regular breaks are taken.
- Impairment of hearing.
- Health hazards caused by breathing dust developed when using your tool (example: working with wood, especially oak, beech and MDF).

NOTE

Vibration emission value during actual use of power tool can differ from declared value depending on how tool is used. Vibration level may increase above level stated.

Vibration

Declared vibration emission values stated in technical data and declaration of conformity have been measured in accordance with a standard test method provided by EN 62841 and may be used for comparing one tool with another.

Declared vibration emission value may also be used in a preliminary assessment of exposure.

When assessing vibration exposure to determine safety measures required by 2002/44/EC to protect persons regularly using power tools in employment, estimation of vibration exposure should consider actual conditions of use and the way the tool is used, including taking account of all parts of operating cycle such as times when tool is switched off and when it is running idle in addition to trigger time.

Labels on battery charger

The following symbols are shown on tool:

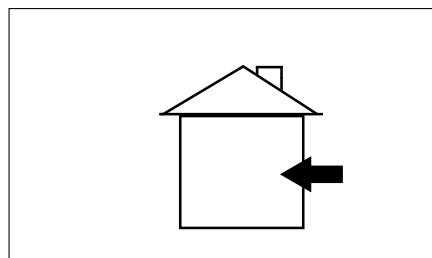
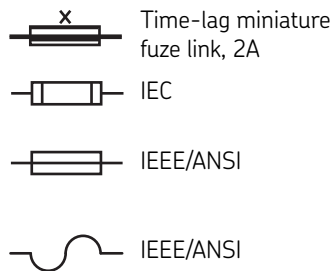

Maintenance

PowerLuber has been designed to operate over long period of time with minimum of maintenance. Continuous satisfactory operation depends upon proper tool care and regular cleaning.

Charger does not require any maintenance apart from regular cleaning.

⚠ WARNING

Do not perform maintenance on tool with battery installed.

Do not clean charger with battery plugged in.

Failure to comply may result in death or serious injury.

NOTE

Regularly clean ventilation slots in tool and charger using soft brush or dry cloth.

Regularly clean motor housing using damp cloth. Do not use any abrasive or solvent-based cleaner.

Regularly open chuck and tap it to remove any dust.

⚠ WARNING

Do not use tool before reading manual to reduce risk of injury.

Failure to comply may result in death or serious injury.



Protect environment

Do not dispose of Lincoln product with household waste. Make product available for separate collection.

Local regulations may provide for separate collection of electrical products from household, at municipal waste sites or by retailer when purchasing new product.

NOTE



Separate collection. Do not dispose of with normal household waste.

NOTE

Separate collection of used products and packaging allows materials to be recycled and used again.

Reuse of recycled materials helps prevent environmental pollution and reduces demand for raw materials.

NOTE



Run battery down completely and remove from tool.
NiCd, NiMH and Li-Ion batteries are recyclable.

Take to any authorized repair agent or local recycling.

Safety instructions for battery and charger

Save these instructions

This manual contains important safety and operating instruction for Lincoln model 1870 battery charger.

⚠ DANGER

Do not probe with conductive objects.

Do not charge damaged battery.

Replace immediately.

Risk of electric shock 120 V AC present at charger terminals.

Failure to comply will result in death or serious injury.

Read all instructions

Batteries

- Never attempt to open for any reason.
- Do not expose battery to water.
- Do not store in locations where temperature may exceed 105 °F (40 °C) such as outside sheds or metal buildings in summer.
- Charge only at ambient temperatures between 50 and 104 °F (10 and 40 °C).
- Charge only using charger provided with tool.
- When disposing of batteries, follow instructions given in section **Protect environment**.

NOTE

Do not attempt to charge damaged batteries.

NOTE

Do not expose battery to fire.



⚠ DANGER

Do not expose battery to spark or flame. Battery liquid may burn.

Do not splash or immerse in water or other liquids. This may cause premature cell failure.

Failure to comply will result in death or serious injury.

⚠ DANGER

Never attempt to open battery pack for any reason. If plastic housing of battery pack breaks or cracks, return to service center for recycling.

Failure to comply will result in death or serious injury.

⚠ CAUTION

Do not charge Lincoln model 1871 battery packs with any other charger.

Do not charge any other type of battery with 1870 battery charger.

Other types of batteries may burst.

Do not clean charger with it plugged into electrical outlet.

Failure to comply may result in personal injury.

Charger

- Before using battery charger, read all instructions and cautionary markings on battery charger, battery pack, and product using battery.
- Do not expose charger to rain, snow or frost.
- Do not abuse cord. Never carry charger by cord or pull on it to disconnect from receptacle. Pull by plug rather than cord when disconnecting charger. Have damaged or worn power cord and strain reliever replaced immediately. Do not attempt to repair power cord.
- Locate cord so that it will not be stepped on, tripped over, or otherwise subjected to damage or stress.
- Do not use extension cord unless absolutely necessary. Use of improper extension cord could result in risk of fire and electric shock.
- Do not operate charger if it has received a sharp blow, been dropped, or otherwise damaged in any way, take it to qualified service center.
- Do not disassemble charger or battery pack. Take it to qualified service center when service or repair is required. Incorrect reassembly may result in risk of electrical shock or fire.
- Unplug charger from outlet before attempting any cleaning to reduce risk of electric shock.
- Charge battery pack in well ventilated place; do not cover charger and battery with anything while charging.
- Do not store charger or battery packs in locations where temperature may reach or exceed 122 °F (50 °C) such as metal tool shed, or car in summer. High temperatures can lead to deterioration of storage battery.

- Do not charge battery pack when temperature is below 40 °F (5 °C) or above 105 °F (40 °C). This is very important for proper operation.
- Do not incinerate battery pack. It can explode in fire.
- Do not charge battery in damp or wet locations.
- Do not short across terminals of battery pack. Extremely high temperatures could cause personal injury or fire.
- This appliance is not intended for use by persons with reduced physical, sensory or mental capabilities or lack of experience and knowledge.
- Lincoln model 1871 battery pack contains rechargeable, lithium-ion batteries. Batteries must be recycled or disposed of properly.
- Drop off expended battery packs at local replacement battery retailer, or recycling center.

NOTE

Do not attempt to replace charger unit with regular main plug. Charger is double insulated and no ground wire is required. Check mains voltage corresponds to voltage on rating plate.

Electrical safety

If supply cord is damaged, it must be replaced by manufacturer or authorized Lincoln service center in order to avoid hazard.

NOTE

Charger is intended for indoor use only.

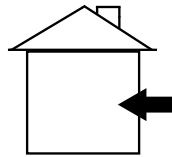

NOTE

Read instruction manual before use.



Tool use and care

- Do not continue to hold down trigger if grease gun is stalled. This could damage motor or cause fire.
- Disconnect battery pack from tool before making any adjustments, changing accessories, or storing tool.
Such preventive safety measures reduce risk of starting tool accidentally.
- Store tools out of reach of children and other untrained persons. Tools are dangerous in hands of untrained users.
- If damaged, have tool serviced before using. Many accidents are caused by poorly maintained tools.
- Use only accessories that are recommended by Lincoln.
- Do not use any accessory that is not capable of handling 10 000 psi (689 bar). Accessories that may be suitable for one tool may create risk of injury when used on another tool.

Table 1

Specifications

Basic PowerLuber model 1890

Operating power	20 V 
Maximum operating pressure	
Low output	10 000 psi (689 bar)
High output	6 000 psi (414 bar)
Grease reservoir capacity	14.5 oz (411 g)
Operating temperature range	0 to 122 °F (-18 to 50 °C)
Operating current	4.0 A
Rated current	5.0 A
Lubricant	Up to NLGI 2
Weight	8.8 lb (4,0 kg)
Grease output	
Low output	3.5 oz/min (99 g/min)
High output	8.9 oz/min (252 g/min)

Accessories

Battery li-ion	Model 1871
Output	20 V 
Capacity	2 500 mAh
Battery charger	Model 1870
Charge time	1 hour
Input	120 V AC, 50 - 60 Hz
Battery charger	Model 1870E
Charge time	1 hour
Input	230 V AC, 50 Hz
Outlet hose	Model 1248HP
Pressure rating	10 000 psi (689 bar)
Length of hose	48 in (1 219 mm)

Sound pressure (LpA) 73.5 dB(A), uncertainty (K) 3 dB(A), acoustic power (LwA) 84.5 dB(A), uncertainty (K) 3 dB(A), vibration emission value (ah) 1.0 m/s², uncertainty (K) 1.5 m/s².

Table 2

Sales model	Battery	Charger	Case
1890	1871	N/A	N/A
1886	1871	1870	280311
1888	1871 (2)	1870	280311
1886E	1871	1870E	280311

Description

Model 1890 PowerLuber is a lithium-ion battery-operated grease gun developed for manual lubrication of grease points.

PowerLuber is driven by a small, low-voltage electric motor that is connected to a gear transmission.

Rotary motion of motor is converted into reciprocating motion of plunger, using yoke mechanism. This PowerLuber is a positive displacement single acting pump.

Technology incorporated into 1890 series PowerLuber includes (→ **fig. 3, page 11**):

- Motor protection preventing overload due to excessive current draw.
- Battery charge indicator displays battery charge.
- LED to help locate grease fittings in dim light.

Inspection

Visually inspect for damaged, loose or missing parts. If equipment is worn or damaged, remove from service. Contact an authorized service center for damage assessment or repair.

Operation

LED

- Tool's trigger turns on LED and motor.
- Short stroke of trigger turns on LED only.
- LED will turn off after 15 seconds, following stop of motor or trigger release.

Light sequence

During normal operation, solid green **Prime** light is displayed on back side of tool. If prime is lost for more than 2 seconds, green light will flash (→ **fig. 1**).

Red **Stall** light illuminates when motor overloads. Prime light remains green during this time. Motor cannot stall without grease in tool. Green light flashes when tool loses prime or is empty of grease (→ **fig. 2**).

Fig. 1

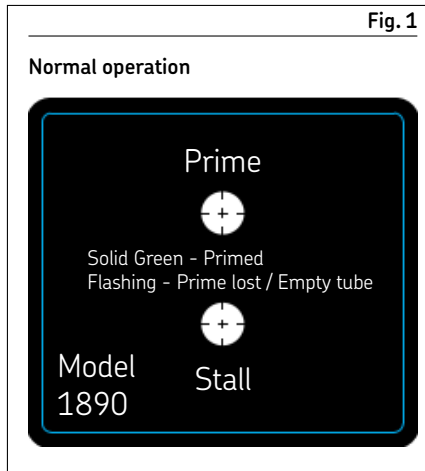
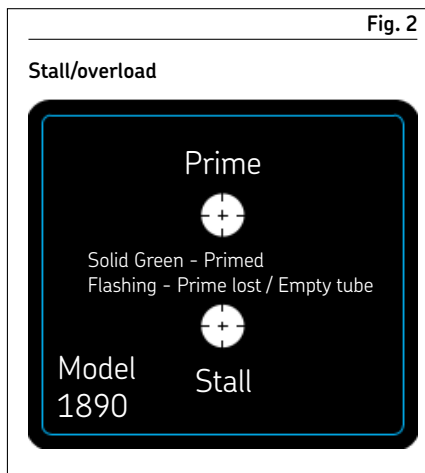

Fig. 2



Change L or H mode

To change mode of operation:

NOTE

Completely stop motor before changing lever to **L** or **H** (low or high) mode of operation to prevent damage to gears in transmission.

L (low output/high pressure)

H (high output/low pressure)

When motor is not running, push gear selector until letter **L** or **H** is completely visible in window.

If gear selector does not completely shift/engage, hold gear selector and toggle switch to engage gears.

For bearings requiring low pressure, below 3 000 psi (206 bar), high output is recommended.

If tool is used to refill small reservoirs of automatic lubrication systems, high output is recommended.

Low output provides maximum pressure of up to 10 000 psi (689 bar) and is suggested when tool is used in construction, mining applications, and general lubrication.

It is normal for batteries to lose power retention capacity over hundreds of charge cycles. Replace battery when this happens.

Prime PowerLuber after each refill or grease cartridge change. Prime gun before using it to lubricate grease points.

To prime, operate gun until grease flows from hose. Use vent valve (17) (→ fig. 3) to expel air pockets.

NOTE

Lincoln recommends this feature only on low output/high pressure mode.

1890 series PowerLuber grease gun

Fig. 3

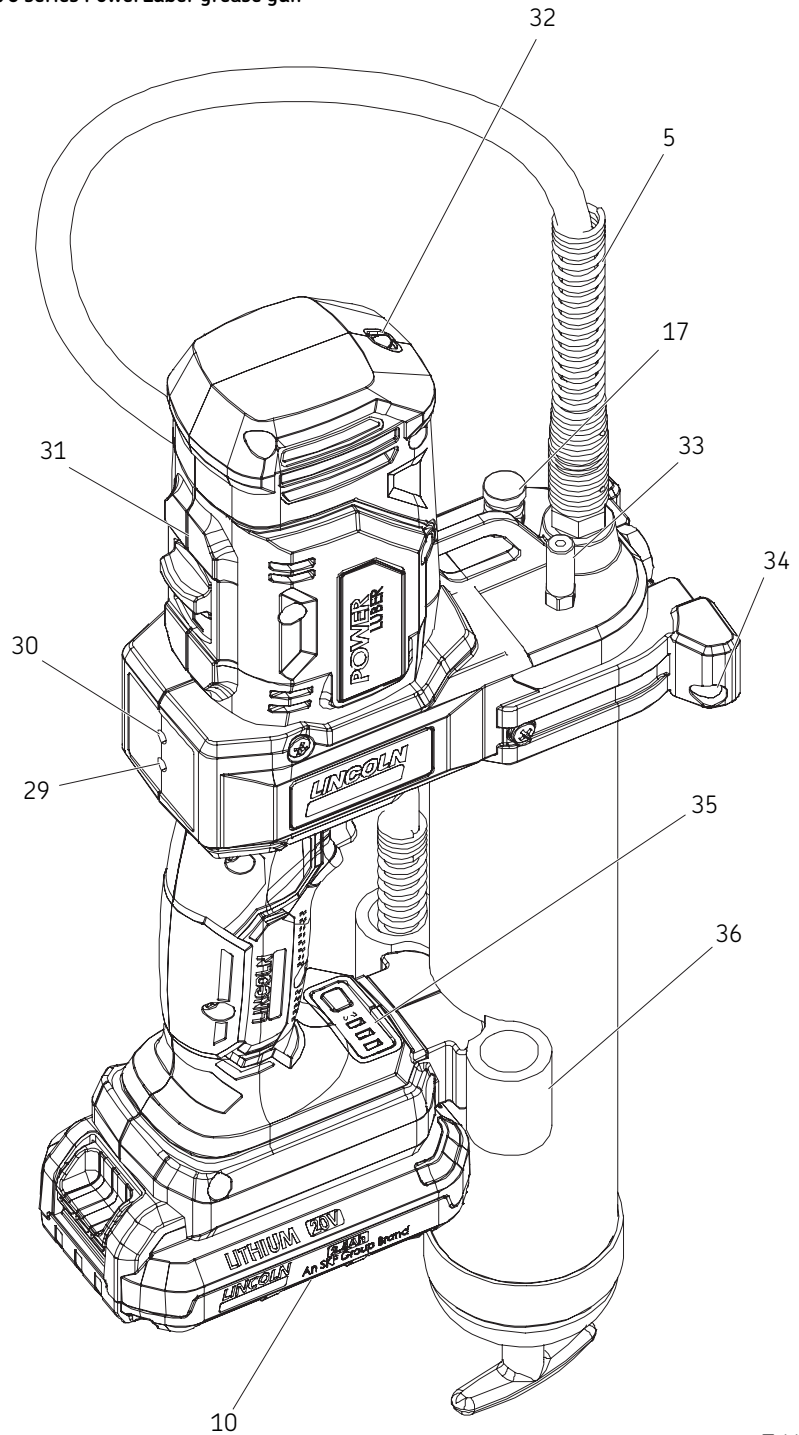

Table 3

Parts

Item	Part	Item	Part
5	Hose 48 in	32	LED
10	Battery	33	Filler nipple
17	Vent valve	34	Support
29	Stall signal	35	Battery gauge/indicator
30	Loss of prime/empty grease tube	36	Hose holder
31	Gear selector		

Replace grease cartridge or refill tube

Prime PowerLuber after each refill or grease cartridge change.

- 1 To prime, operate gun until grease flows from hose.
- 2 Use vent valve (17) (→ fig. 3, page 11) to expel air pockets.

Priming instructions

- 1 Open vent valve (17) (→ fig. 3, page 11).
- 2 Operate gun until grease flows from vent valve (17).
- 3 Close vent valve (17).

Install grease cartridge

- 1 Unscrew grease tube assembly from PowerLuber.
- 2 Pull back on follower handle and latch follower rod groove into slot on tube cap.
- 3 Remove plastic cap from grease cartridge and insert cartridge into container tube.
- 4 Remove pull tab from grease cartridge and screw grease tube assembly into pump assembly.
- 5 Thread grease tube assembly back onto power head.
- 6 Release follower rod from slot. Purge air from pump. Refer to **Expel air pockets, page 13** for air purging instructions.

NOTE

Air pockets in cartridge lubricant cause grease gun to lose prime.

Always open vent valve (17) after replacing cartridge. This allows air to escape from cartridge and prime grease gun.

Prime PowerLuber after each refill or grease cartridge change.

Fill gun from bulk container

- 1 Remove pump assembly from grease tube assembly.
- 2 Pack lubricant into cavity of pump assembly.
- 3 Insert open end of grease tube assembly into lubricant. Slowly pull follower handle back while pushing grease tube assembly deeper into lubricant to prevent air pockets from being pulled into grease tube.
- 4 With follower rod fully extended, pull it sideways to latch rod groove into slot in grease tube assembly cap.
- 5 Loosely assemble pump to grease tube assembly. Release follower rod from grease tube assembly cap and disengage follower rod from follower by rotating follower handle.
- 6 Push follower rod into grease tube assembly.
- 7 Unscrew grease tube assembly from pump until lubricant oozes from interface. Tighten grease tube assembly into pump assembly.

Fig. 4

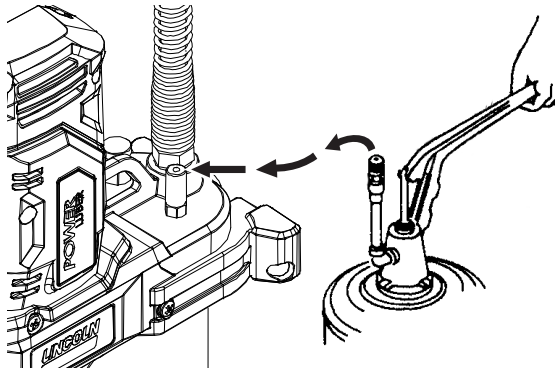

Fill gun with filler pump

- 1 Engage follower rod with follower by rotating follower handle.
- 2 Insert gun bulk fill valve into filler pump socket.
- 3 Operate filler pump to fill container.

NOTE

Do not overfill.

When follower rod groove is exposed, grease tube assembly is filled. Follower rod will be extended approximately 8 in (20 cm).

- 4 Disengage follower rod from follower by rotating follower handle.
- 5 Push follower rod into grease tube assembly.

NOTE

Remove air pockets. Air pockets at grease inlet prevent grease from being pumped.

Unscrew vent valve three to four turns to remove small air pockets trapped in this area.

If air pocket is substantial and no grease flows from coupler after trigger is pulled for 15 seconds, refer to **Expel air pockets (air purging)**.

Expel air pockets (air purging)

- 1 Withdraw follower rod from grease tube assembly cap.
- 2 Engage follower rod with follower by rotating follower handle.
- 3 Unscrew plug of vent valve three to four turns.
- 4 Exert force on follower handle until grease flows through small hole in side of vent valve.
- 5 Tighten vent valve.
- 6 If steps 3-4 fail, unscrew grease tube assembly three turns from pump assembly.
- 7 Pull trigger in short bursts to operate gun until trapped air is expelled.
- 8 Disengage follower rod from follower by rotating and exerting force on follower handle.
- 9 Push follower rod into grease tube assembly.
- 10 Exert force on follower handle until lubricant oozes from grease tube assembly and pump assembly mating surfaces.
- 11 Retighten grease tube into pump assembly.
- 12 Disengage follower rod from follower by rotating follower handle.
- 13 Push follower rod into grease tube assembly.

Charger operation

Charging battery pack

Before using PowerLuber for the first time, battery pack should be fully charged. If battery pack is installed in PowerLuber, remove it and follow charging procedure.

Lincoln chargers are designed to charge Lincoln lithium-ion batteries in 30 to 90 minutes depending on battery's state of charge and temperature.

Charging procedure

Do not use charger with any voltage other than what is shown on charger specification plate.

- 1 Plug charger into appropriate outlet before inserting battery pack.
- 2 Insert battery pack into charger. Green (charging) light will blink continuously indicating that charging process has started.
- 3 Charge is complete when solid green light is shown on charger.
- 4 Disconnect charger from power source when not in use.

⚠ CAUTION

Do not probe charger with any tool or object that may short circuit battery. 120 VAC present at charging terminals. Failure to comply may result in death or personal injury.

NOTE

Do not charge battery immediately after use. Battery will not accept a full charge.

Do not charge until battery has reached room temperature for best results.

NOTE

Do not obstruct vent slots in top or bottom of charger.

Do not charge battery when temperature is below 40 °F (5 °C) or above 104 °F (40 °C).

Important charging notices

Longest life and best performance can be obtained if battery is charged when air temperature is between 65 and 75 °F (18 and 24 °C).

Do not charge battery in air temperature below 40 °F (5 °C) or above 105 °F (41 °C). This is important and will prevent serious damage to battery.

- 1 Charger and battery may become warm to touch while charging. This is a normal condition, and does not indicate a problem.
- 2 If battery does not charge properly:
 - 2.1 Check current at receptacle by plugging in lamp or other appliance.
 - 2.2 Check to see if receptacle is connected to light switch that turns power off when you turn out lights.
 - 2.3 Move charger and battery to location where surrounding air temperature is between approximately 65 and 75 °F (18 and 24 °C).
 - 2.4 If charging problems persist, take tool, battery and charger to local service center.

- 3 Battery should be recharged when it fails to produce sufficient power on jobs.

NOTE

Do not continue to use under these conditions. Follow charging procedure. You may also charge partially used pack whenever you desire, with no adverse affect on battery.

- 4 Under certain conditions, with charger plugged into power supply, exposed charging contacts of charger can be shorted by foreign material.

Foreign materials of conductive nature such as, but not limited to, steel wool, aluminum foil, or any build up of metallic particles should be kept away from charger cavities.

NOTE

Always unplug charger from power supply when there is no battery in cavity. Unplug charger before attempting to clean.

⚠ WARNING

Do not allow any liquid inside charger. Electric shock may result.

To facilitate cooling of battery pack after use, avoid placing charger or battery pack in warm environment such as metal shed or non-insulated trailer.

Failure to comply may result in death or serious injury.

Table 4

Indicator light operation

—————	Charge is complete (solid green)
-----	Battery charging (flashing green)
.....	Red, at a fast rate. Replace battery
-----	Charger detected a weak or damaged battery. Stop charging battery. Hot/cold pack delay. Charger detected a battery that is excessively hot or cold. It automatically starts a hot/cold pack delay, suspending charging until temperature of battery has normalized. After this, charger automatically switches to battery charging mode.

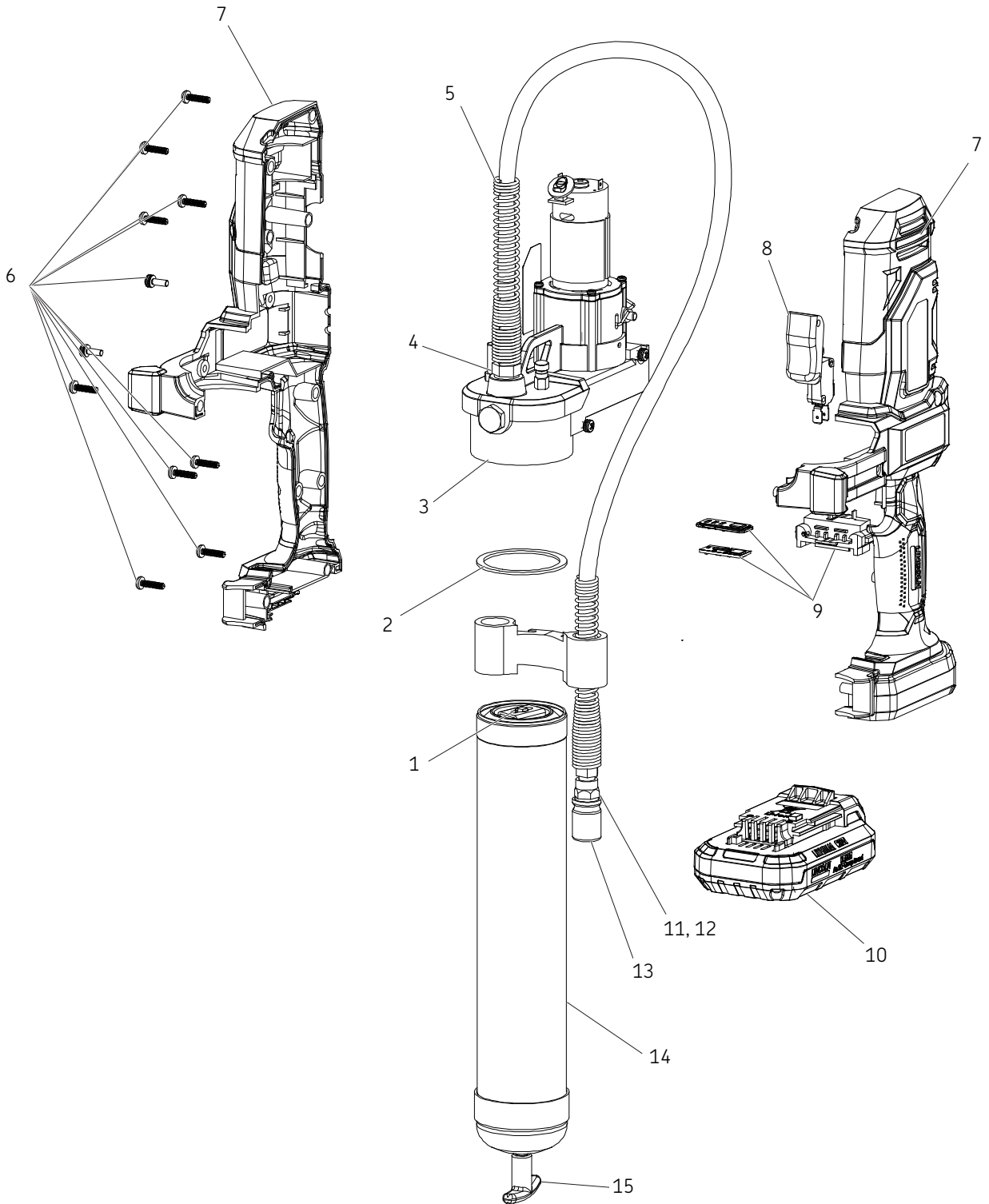

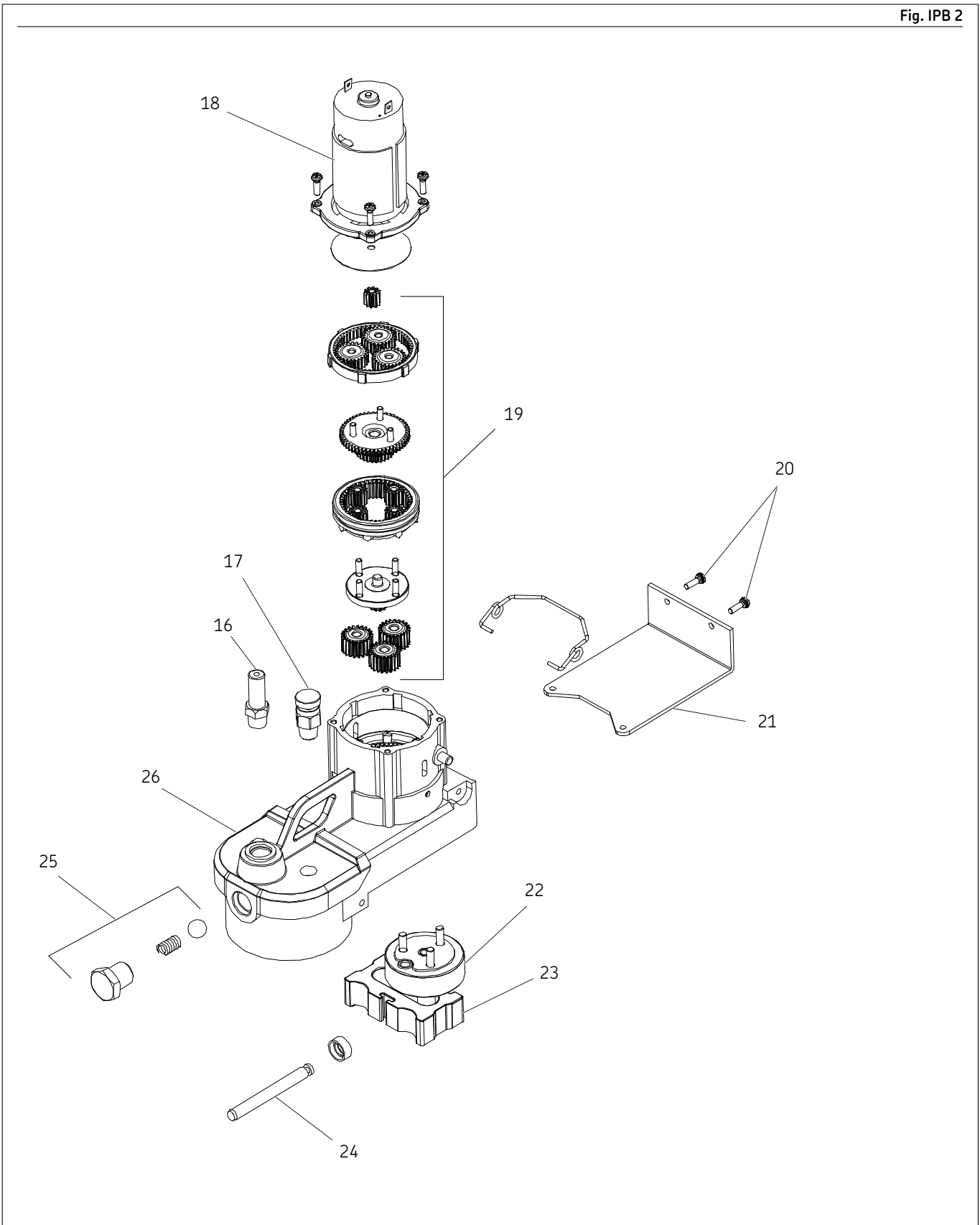

Table 5

Parts list		
Item	Description	Part number
1	Follower assembly kit	272072
2	Packing	34793
3	Pump assembly kit	280330
4	Gasket (hose) kit	271884
5	Hose 3/16 in ID x 42 in	1248HP
6	Hardware kit (1260)	280213
7	Handle with screws kit	280332
8	Trigger, switch kit	280235
9	Electrical components kit	280331
10	Battery 20V (Li-Ion)	1871
11	Coupler, midget hyd	5852
12	Coupler, European midget	251-10124-7
13	Coupler cap kit	286419
14	Grease tube kit	271882
15	Handle kit	286090
16	FTG, Filler 1/8 NPT	91108
17	Vent valve kit	286315
18	Motor with plate kit	280336
	Motor with plate kit, European	280336E
19	Gear set kit	280257
20	Pump hardware kit	286105
21	Cover pump kit	286106
22	Driver assembly kit	286285
23	Yoke kit	286107
24	Plunger kit	286109
25	Check valve kit	280335
26	Housing with bearing 1890 kit	280334
27	Charger 12-20V (Li-Ion)	1870 ¹⁾
28	Charger (E) 12-20V (Li-Ion)	1870E ¹⁾
29	Stall signal	N/A
30	Loss of prime / empty grease tube	N/A
31	Gear selector	N/A
32	LED	N/A
33	Filler nipple	N/A
34	Support	N/A
35	Battery gauge/indicator	N/A
36	Hose holder	N/A

¹⁾ Not shown.

Table 6

Troubleshooting

Condition	Possible cause	Corrective action
PowerLuber fails to dispense grease.	Grease tube assembly is out of grease.	Check that grease tube assembly (14) has grease.
	Loss of prime.	Repeat priming operation.
	Ball check is not functioning.	Remove check ball (25). Clean and inspect ball seat area.
	Clogged whip hose.	Clean or replace whip hose (5).
PowerLuber continues to lose prime.	Air may be trapped in several locations in container after bulk filling.	Empty grease tube assembly (14), refill and repeat priming instructions.
	Follower may be binding in grease tube assembly.	Disassemble grease tube assembly (14) and clean. Be sure that follower (1) has properly entered grease cartridge.
		Verify that follower (1) is not caught on rim of grease cartridge.
		Replace grease tube assembly (14) if damaged.
Battery fails to take a charge.	Check ball seat and check ball dirty.	Clean check ball (25) and check ball (25) seat.
	Charger may not have power.	Check that receptacle has power.
Motor fails to run.	Battery may be bad.	Replace battery (10).
	Battery needs charging.	Recharge battery (10).
	Faulty wiring to motor.	Remove battery (10), disassemble handle and check wiring connections on terminal, trigger switch (8) and motor (18).

Declaration of conformity according to EMC directive 2014/30/EU

We declare that the model of the PowerLuber grease gun 1886E, complies with the provisions of the above mentioned directive. Applied harmonized standards in particular:

EN 55014-1:2017
Electromagnetic compatibility – requirements for household appliances, electric tools and similar apparatus – Part 1: Emission – Product Family Standard

EN 55014-2:2015
Electromagnetic compatibility requirements for household appliances, electric tools and similar apparatus – Part 2: Immunity. Product Family Standard



St. Louis, MO August 2019
Brad Edler, Director Product Development and Product Engineering

Declaration of conformity as defined by machinery directive 2006/42/EC and low voltage directive 2014/32/EU

We declare that the model of the PowerLuber grease gun 1890 in the version supplied by us complies with the provisions of the above mentioned directive. Applied harmonized standards in particular:

EN 62841-1:2015
Hand held motor-operated electric tools. Safety general requirements.

Declaration of conformity as defined by machinery directive 2006/42/EC

We declare that the model 1871 battery charger in the version supplied by us complies with the provision of the above mentioned directive. Applied harmonized standards in particular:

EN 60335-1: 2012
Household and similar appliances – industrial. Safety. Part 1. General requirements.

EN 60335-2-29: 2004+A2: 2010
Household and similar appliances industrial. Safety. Part 2. Particular requirements for gas, oil appliances having electrical connectors.

EN 62233:2008
Measurement method for electromagnetic fields of household appliances and similar apparatus with regard to human exposure.

Warranty

The instructions do not contain any information on the warranty. This can be found in the General Conditions of Sales, available at: www.lincolnindustrial.com/technicalservice or www.skf.com/lubrication.

skf.com | lincolnindustrial.com

® SKF and Lincoln are registered trademarks of the SKF Group.

© SKF Group 2019
The contents of this publication are the copyright of the publisher and may not be reproduced (even extracts) unless prior written permission is granted. Every care has been taken to ensure the accuracy of the information contained in this publication but no liability can be accepted for any loss or damage whether direct, indirect or consequential arising out of the use of the information contained herein.
August 2019 · Form 400303 Version 1