

DOORMINATORTM_{USA}

DOOR HANDLER

OPERATOR'S MANUAL

For Model 40100



⚠ WARNING ⚠

Read and become familiar with this manual **BEFORE** operating unit.

Before operating this equipment, thoroughly read this set of instructions, make sure you understand them, and only then follow the step-by-step directions. Failure to do so could result in serious property damage and / or serious bodily injury.

MADE BY **PARAGON PRO**
MANUFACTURING SOLUTIONS

www.paragonpromfg.com

To our valued customer,

Thank you for choosing a **Telpro Inc.**® product by **PARAGON PRO** Manufacturing Solutions. We are pleased that we are able to provide equipment to make your work easier.

Our efforts are focused on producing the finest quality equipment of which we are capable. We make sure to spend extra time and effort on our design and production in order to reduce your time and effort spent using the product.

We take pride in providing the best for our customers. Quality, innovation, and excellence are all qualities this company ensures. No product is sent without being factory tested and inspected to ensure the highest quality for you.

It all began in 1972 when Roland Young designed our first product, the PANELLIFT® Brand Drywall Lift, and revolutionized the drywall industry. To this day we are continuously making advancements in manufacturing and design.

Thank you again for giving us the opportunity to work with you. Any questions or comments that you have are always welcome.

PARAGON PRO
M a n u f a c t u r i n g S o l u t i o n s

CONTENTS

Warnings / Instructional Information	Page 1
Care & Maintenance	Page 2
User Components & Specification	Page 3
Initial Assembly	Pages 4
Terms & Definitions	Pages 5-6
Operation	Pages 7-12
Parts Index	Page 13
Notes	Page 14
Other Products	Page 15
Order Form	Page 16

www.paragonpromfg.com

All photos are for illustrative purposes only. Always wear proper Personal Protective Equipment.

Warning

Read and follow these warnings and the instructions that follow. Failure to do so could result in serious property damage and/or serious bodily injury.

- Never release the roller pads while a door is loaded on the Doorminator®. The door will lose its support and tip or fall possibly resulting in personal injury or property damage.
- When using the Doorminator® as a dolly to transport doors, proceed slowly and carefully, especially around corners to avoid tipping.
- Doorminator® is to be used only on *hard, level floors* capable of supporting the weight of itself plus the weight of the door.
- The door must be *centered, side to side on the carrier*. If the door is not centered on the carrier, it might slip off and fall possibly resulting in personal injury or property damage. NOTE: Carrier is a separate part from the frame - hold onto it when loading doors and when releasing Doorminator® from a hung door.
- Do not push or pull on the door itself when attempting to move a loaded Doorminator®. The door may be dislodged from the carrier and fall possibly resulting in personal injury or property damage. Move the loaded Doorminator® by carefully guiding the upright frame end of the unit.

Questions? - Call Our Customer Service at 1-800-448-0822 or 1-800-441-0551



- ✓ Occasionally lubricate wheels and casters, hinge points, pull pins, and frame latch.
- ✓ Store Doorminator® in a dry place.
- ✓ Adjust door tilt and carrier tilt handles as needed by tightening or loosening their nuts and bolts.

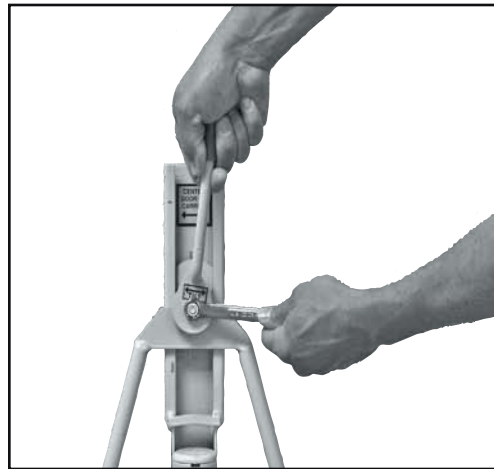
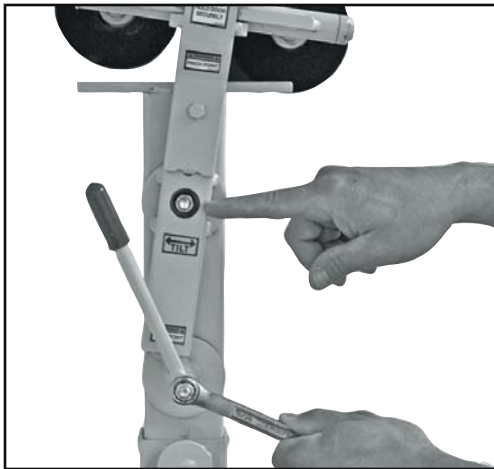

- ✓ Take reasonable care to avoid damaging the Doorminator® when transporting it.

USER COMPONENTS and SPECIFICATIONS

Model 40100

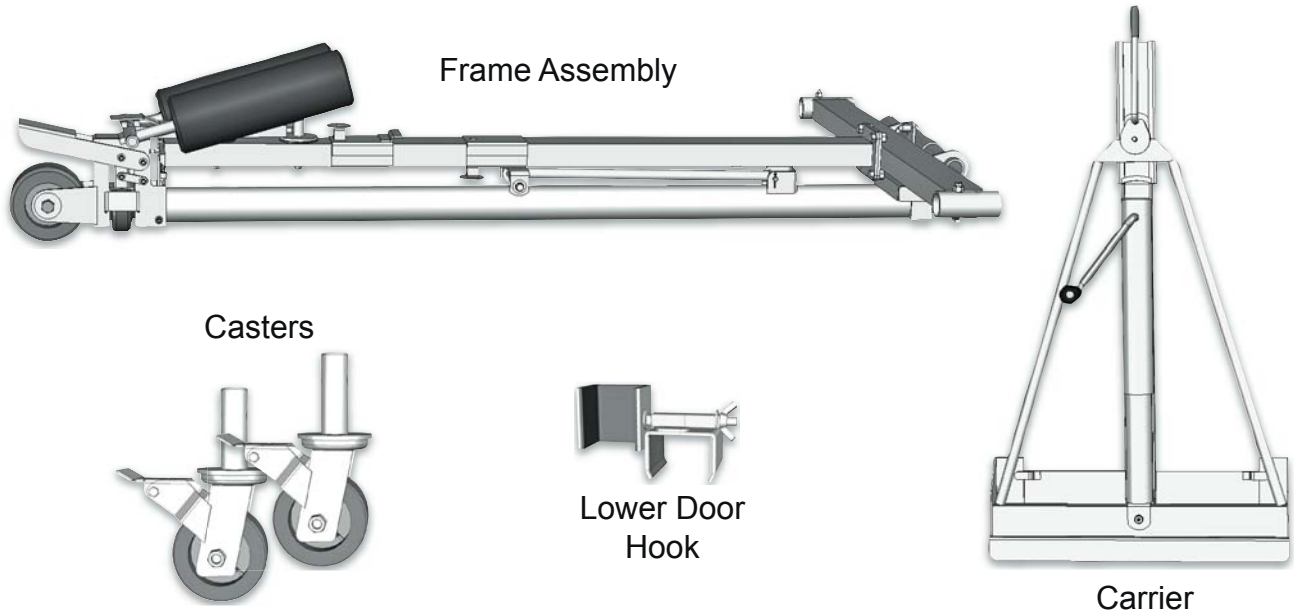

Specifications:

- Doorminator® Load Limit 400 lbs.
- Maximum Door Dimensions: 4'W x 10'H x 2"D
- Net Weight: 111 lbs.
- Model No. _____ Serial No. _____

INITIAL ASSEMBLY - Model 40100

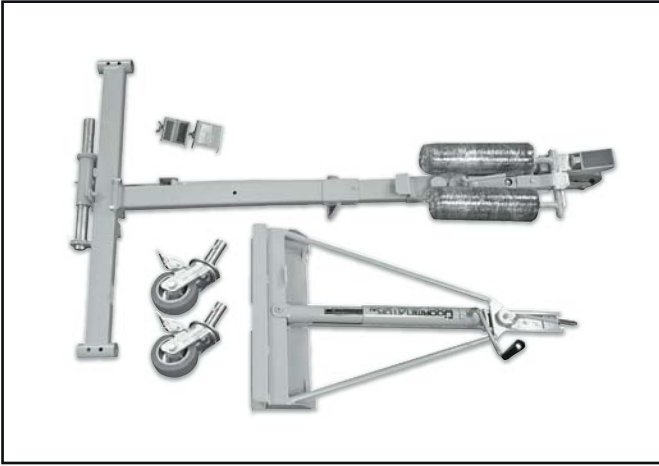

1. Unpack unit.



4. Bolt on crank handle to door carrier.



2. Bolt in two casters with fasteners.



5. Hang carrier on storage pin and fasten to frame with storage latch pull pin.

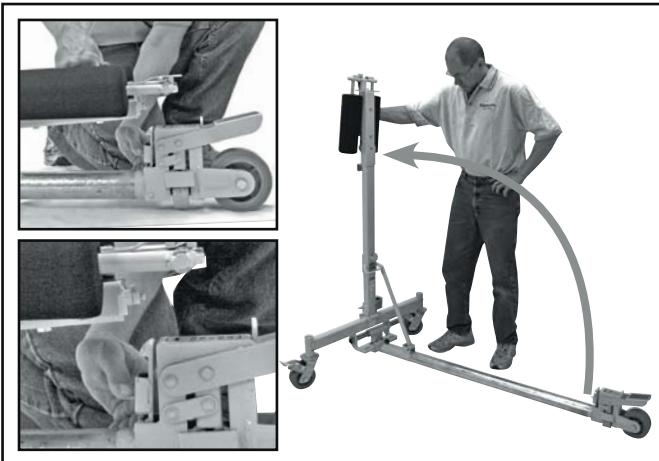

3. Release wheel base catch and lift the frame to upright position until brace pull pin engages in locked position.

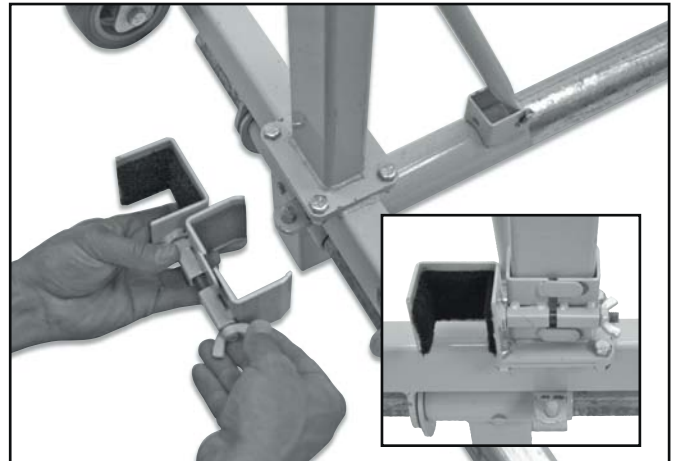

6. Clamp the lower door hook in storage position on frame as shown.

TERMS & DEFINITIONS

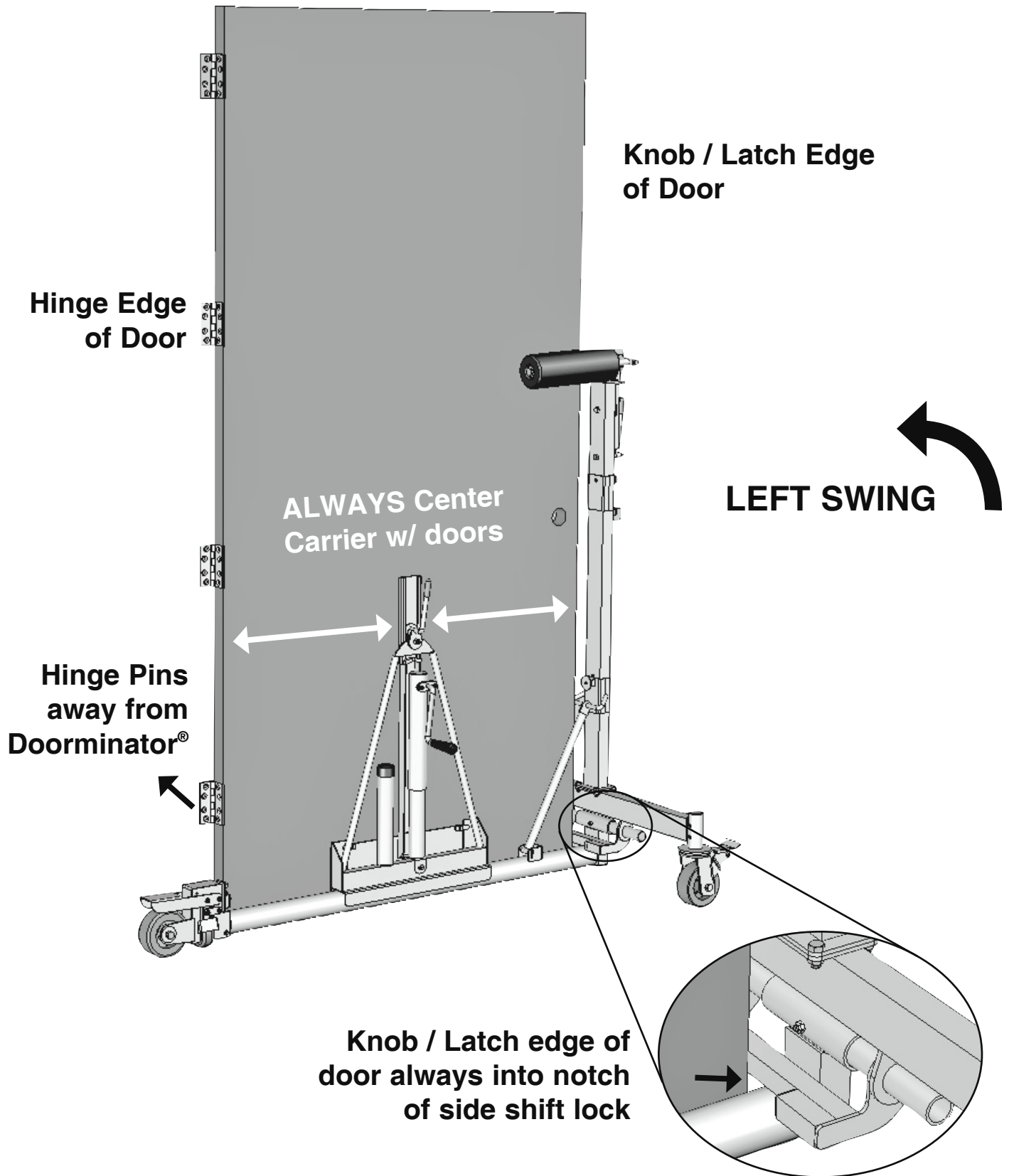

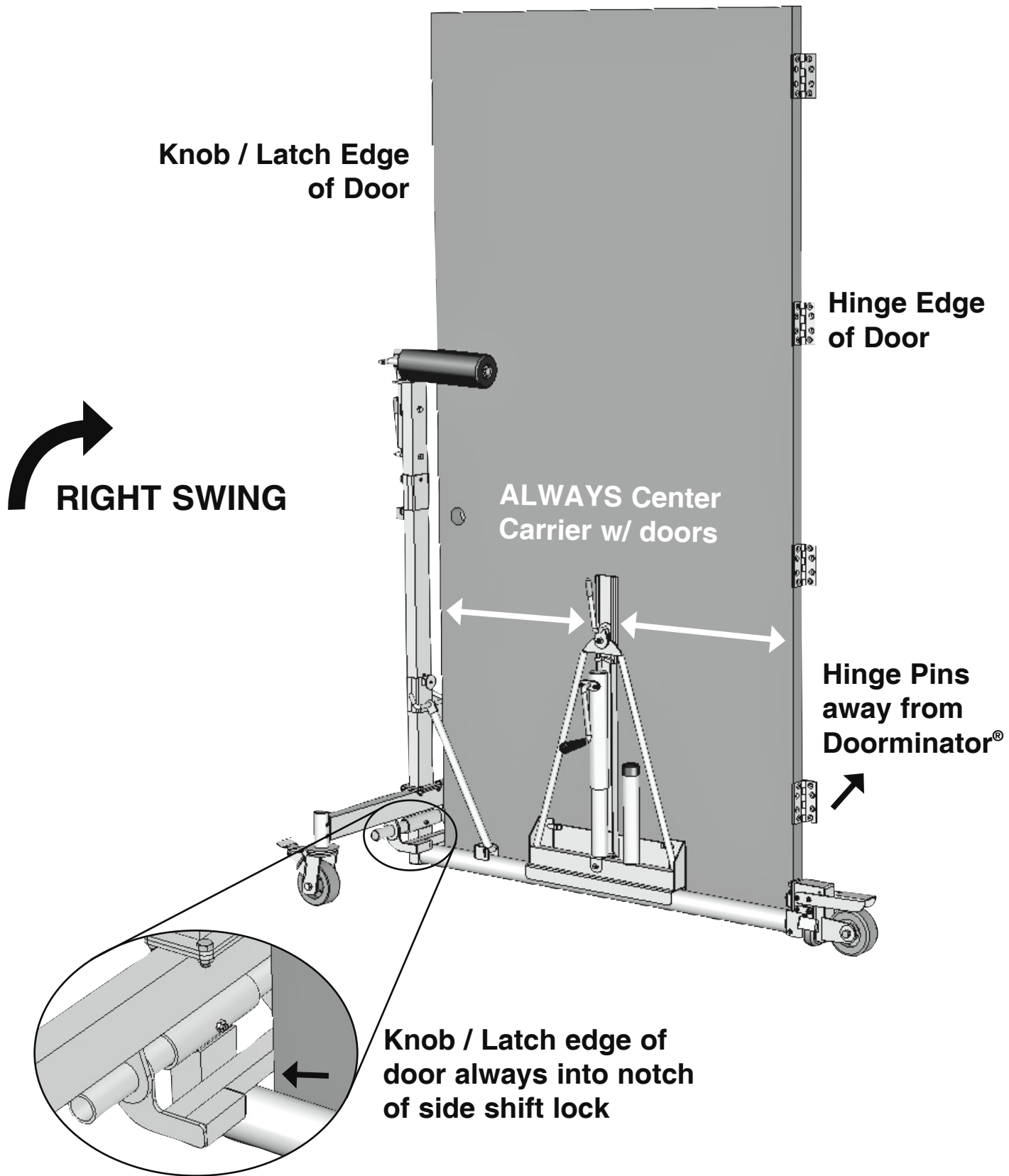

OPERATION: LOADING THE DOOR

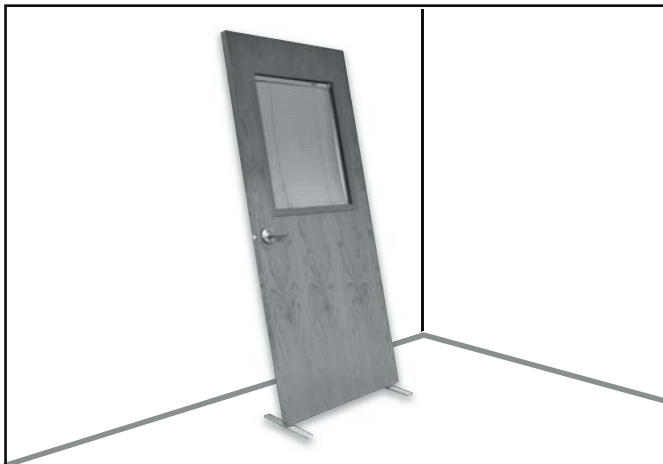

1. Begin with door 18" - 20" away from and leaned against the wall (with hinge pins toward wall) and supported on lower corners by laths or similar spacer shims to provide easy access for carrier door shoe.



2. Position Doorminator® near the door with the upright frame at the latch side of door and the step-down transverse wheel at the hinge side of door.

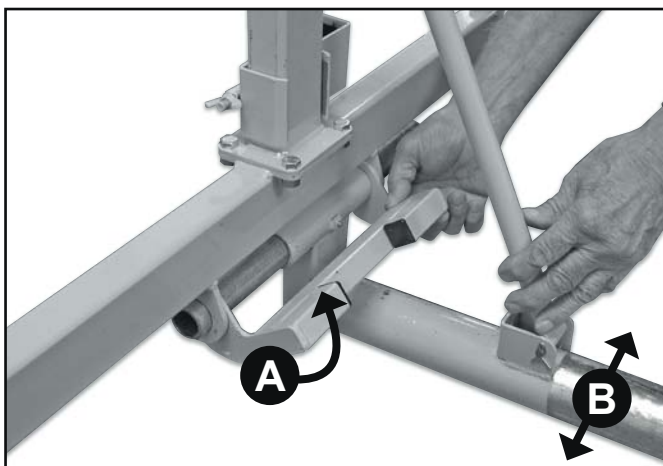

3. Check to see that the frame is set correctly for left swing or right swing doors. Raise side shift lock "A" and shift the wheel base "B" left or right as needed. See details on pages 5-6.



4. Release carrier slide box latch, swing top of carrier left or right and lift it off of storage pin.



5. Position carrier under the door and be sure to *center it, side to side*, with the door! Be sure hinge pins are on the side of the door away from Doorminator®. See details on pages 5-6.

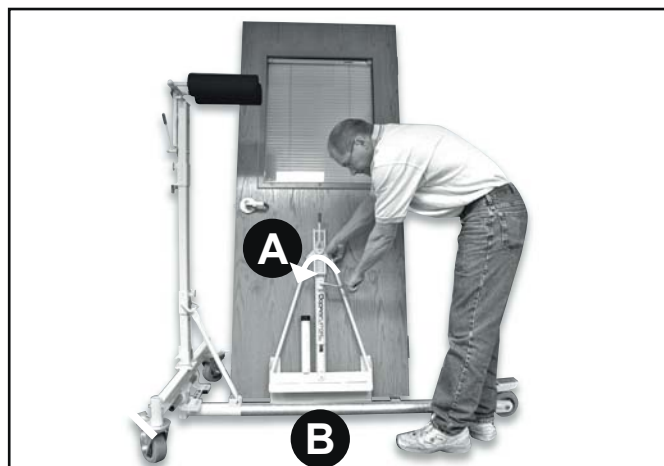

6. Crank handle "A" counterclockwise to raise carrier channel high enough to allow wheel base "B" to pass underneath.

OPERATION: LOADING THE DOOR



7. While holding the door carrier against door with one hand, move wheelbase into position until latch edge of door is engaged in notch of the side shift lock as shown.



8. Lock caster brake to hold in position.



9. Turn the crank handle clockwise until carrier channel contacts top of wheel base and just begins to lift door.



10. Swing the first roller pad (furthest from wall) around to horizontal position and grasp door with two hands.



11. With your foot braced against the door carrier, carefully pull door toward you to the vertical position against the first roller pad.



12. Immediately swing the second roller pad around to horizontal position behind the door to hold the door on the Doorminator®. **WARNING:** Do not release the roller pads if door is not mounted on hinges or firmly controlled! Door will tip and come off of the Doorminator®.

OPERATION: LOADING THE DOOR

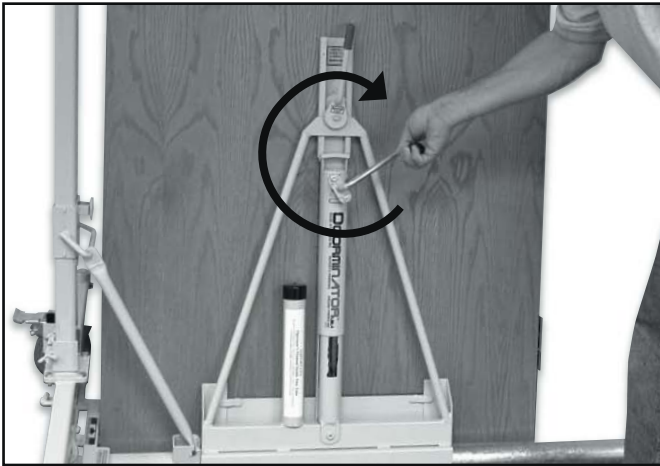

13. Crank carrier handle clockwise to raise door for transport.

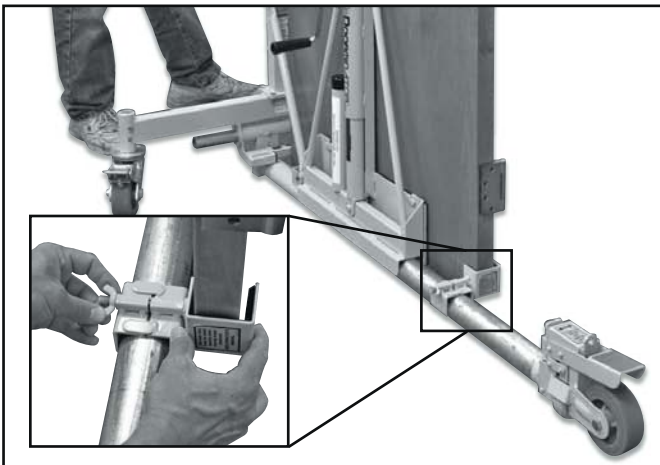

14. You may choose to use lower door hook for added security when moving doors longer distances.

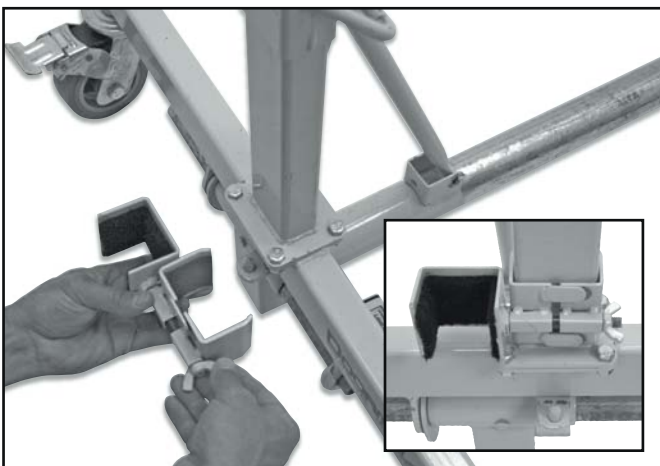

15. When not in use, the lower door hook clamps onto frame upright tube for storage.



16. When using the Doorminator® as a dolly to transport doors, proceed slowly and carefully, especially around corners to avoid tipping.

OPERATION: INSTALLING THE DOOR

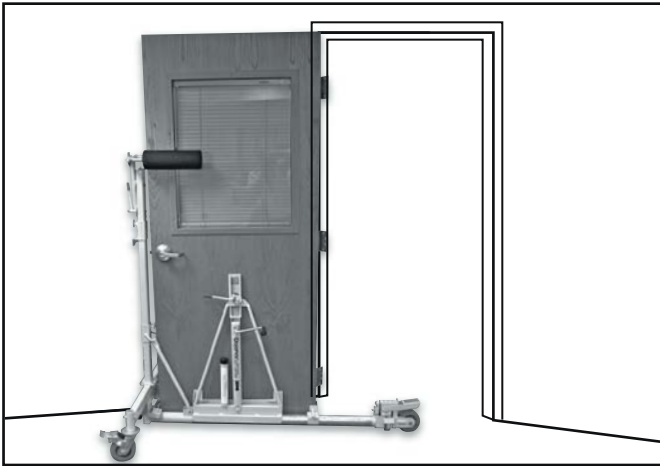

1. Roll the loaded Doorminator® into position so that the door hinges line up with the mounting surface in the door frame. **WARNING:** Do not push directly on the door to move it. It may be dislodged from door carrier and tip over possibly resulting in damage or injury.

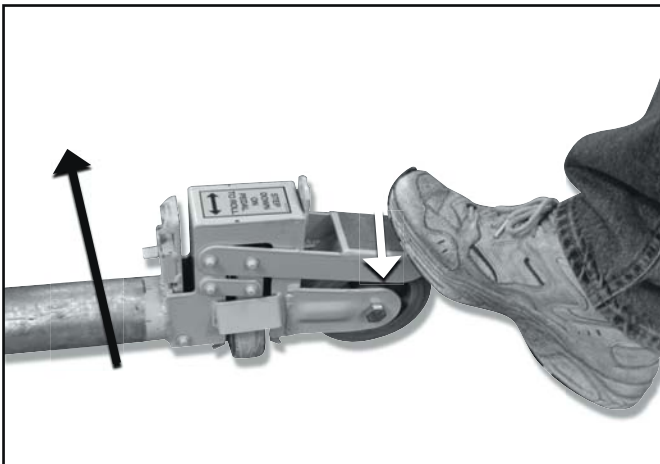

2. To move hinge side of door laterally closer to the frame, step down and sideways on wheel pedal to activate transverse wheel.

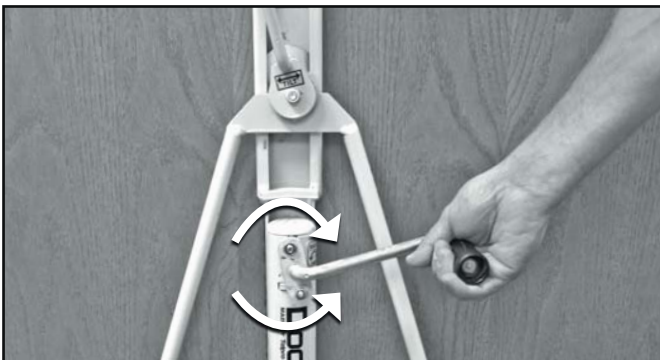

3. To raise door turn the crank clockwise.
To lower door, turn the crank counter-clockwise.

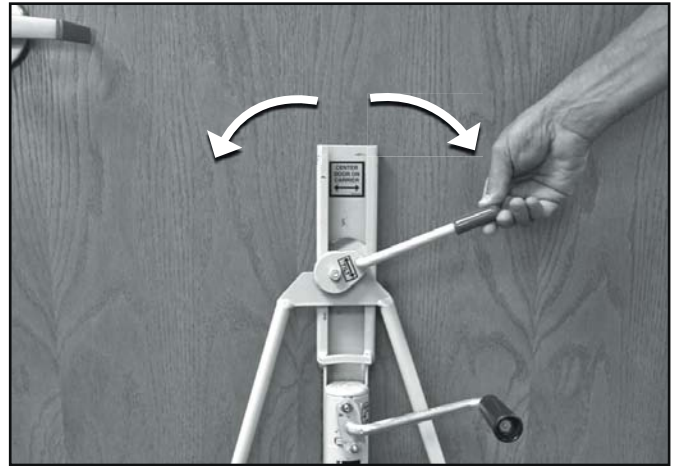

4. To tip door side to side, use carrier tilt handle.

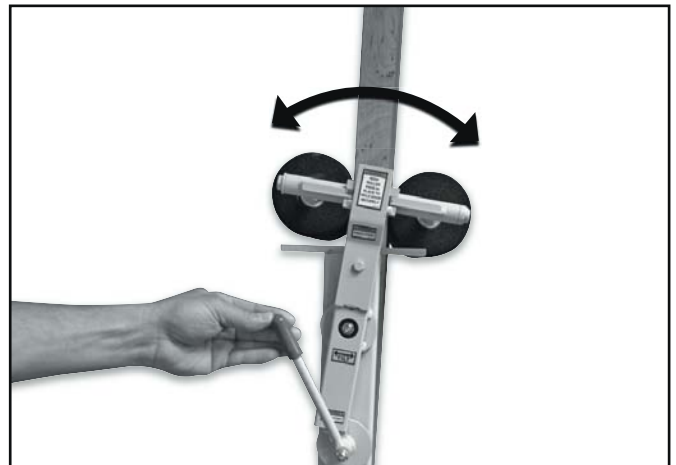

5. To tip door front to back, use door tilt handle.



6. When hinges line up properly, install screws to fasten door into frame.

OPERATION: INSTALLING THE DOOR



7. After door is securely mounted on its hinges, release roller pads by pulling back on latch bar.



8. Flip the roller pads around to the vertical position.

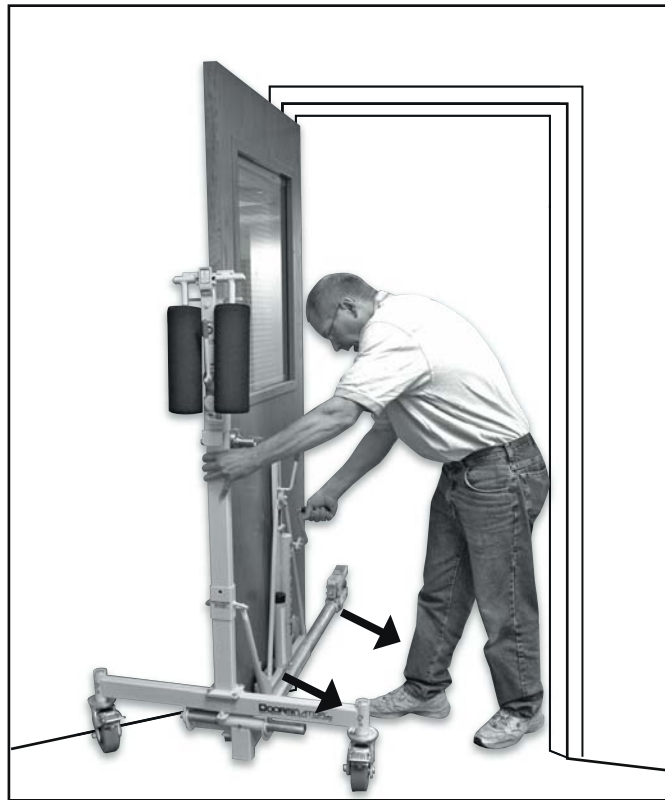

9. Crank the handle counter clockwise until carrier is free from the bottom of door. Then while holding carrier with one hand so it will not tip off and fall, move it together with Doorminator® frame away from the door.



10. As soon as it's free and clear you can lift the carrier off of the wheel base and return it to its storage position on the upright tube.

OPERATION: FOLDING & TRANSPORT



1. To fold unit for transport and compact storage begin with roller pads hanging in the vertical position. Pull on the brace slide box pin to release and carefully lower the upright frame down until it latches with the wheelbase.

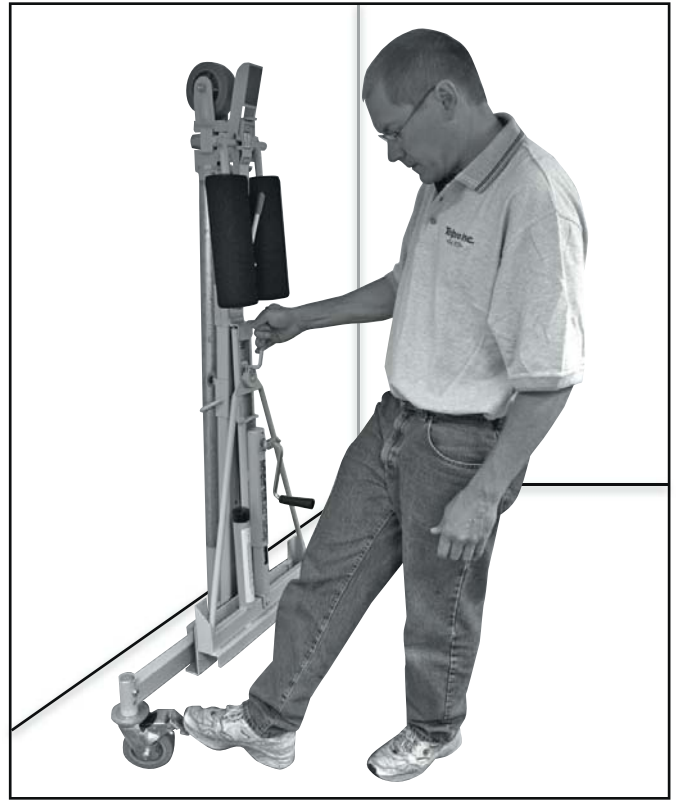

2. Now the Doorminator® can be easily rolled to its storage location. If unit is leaned against wall for storage - be sure to lock both caster brakes.

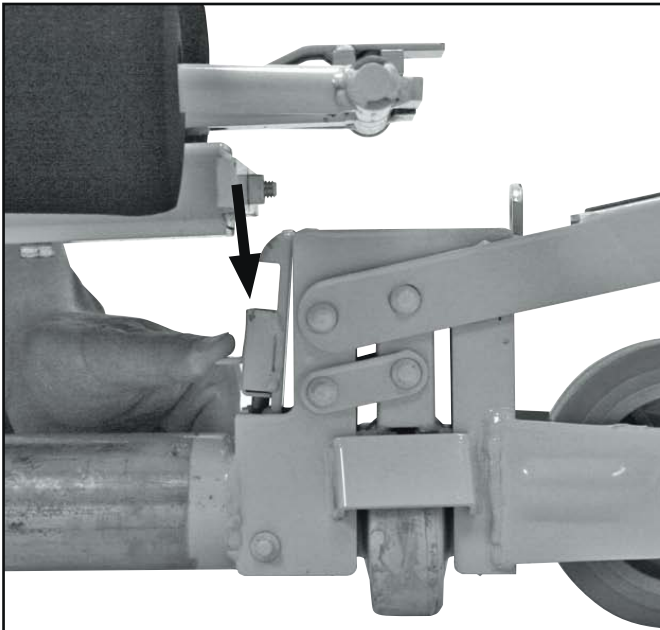

Be sure latch engages completely.

COMPLETE DOORMINATOR® ASSEMBLY

PART NUMBER	DESCRIPTION
10-00	5" Caster W/Fast
64-01	Caster Base W/Fast
64-02	Wheel Base W/Fast
64-03	3" Wheel Assembly
64-06	5" Wheel W/Fast
64-07	Side Shift Lock
64-08	Side Shift Tube
64-09	Upright Tube W/Fast
64-11	Brace Slide Box W/Fast
64-12	Carrier Slide Box
64-13	Top Latch Assembly
64-14	Door Tilt Assembly
64-15	Latch Bar W/Fast
64-16	Roller Arm W/Pin
64-17	Pair Roller Pads
64-18	Door Tilt Handle W/Fast
64-19	Wheel Base Catch W/Fast
64-20	Lower Door Holder W/Fast
65-00	Complete Carrier
65-01	A Frame
65-02	Jack Frame W/Fast
65-03	Carrier Tilt Handle W/Fast

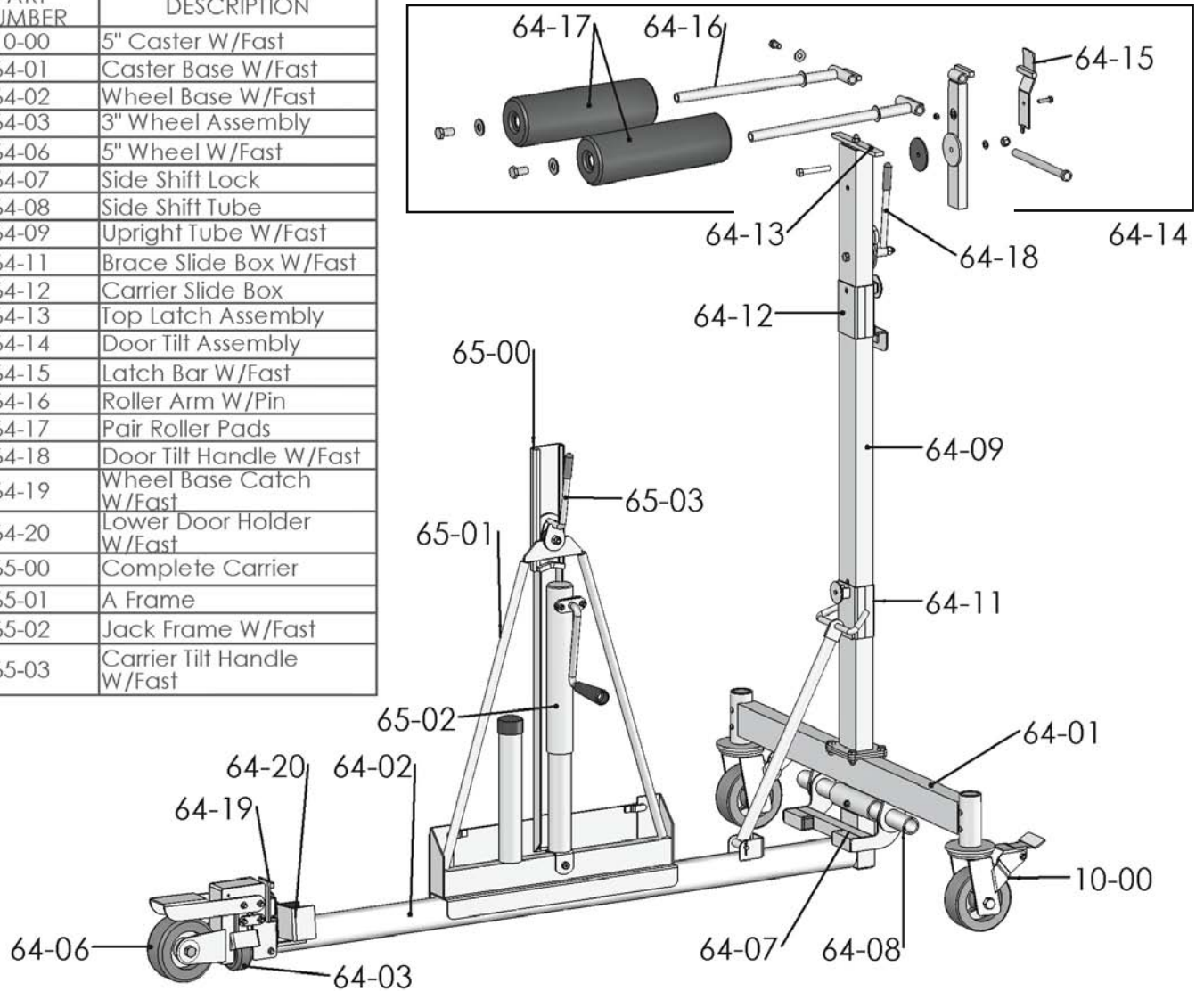

PARAGON PRO MANUFACTURING SOLUTIONS INC

LIMITED WARRANTY

TELPRO INC products manufactured by PARAGON PRO MANUFACTURING SOLUTIONS INC are warranted to be free from defects in material and workmanship under normal use for one year from date of purchase.

NOTE: The following components of the **PANELIFT® Model 439** Drywall Lift are warranted to be free from defects in material and workmanship under normal use for three years from date of purchase.

Part#	Description		
52-03	#35 chain assembly	52-05	#40 chain assembly
52-07	#50 chain assembly	52-09	1 1/4" #50 roller assembly
52-10	Outer plate set w/ bronze bearings	52-11	Drive assembly
52-12	1/2" x 2 1/4" Shoulder bolt w/ fasteners	52-15	Clutch assembly w/ sprocket
52-16	#40 winch drive chain		

If a TELPRO INC product is proven to be defective in material or workmanship within the covered time frame from the date of purchase, return the defective part to PARAGON PRO MANUFACTURING SOLUTIONS INC and we will either repair or replace the part at our option. We will neither assume nor authorize any other person to assume for us any other liability.

Written notice including commercial invoice detailing the nature of the defect, date of purchase, and the company from which you purchased your unit must be received and acknowledged by PARAGON PRO MANUFACTURING SOLUTIONS INC before any units may be returned. Shipping costs shall be the responsibility of the product purchaser.

This warranty shall not apply to any equipment that has been repaired or altered outside of the factory in any way so as in our judgment to affect its stability or reliability nor which has been subjected to abuse, misuse, or negligence.

PARAGON PRO MANUFACTURING SOLUTIONS INC reserves the right to make changes or improvements in design without incurring obligation to install the same on previous units.

PARAGON PRO MANUFACTURING SOLUTIONS INC shall not be liable for loss, damage, or expense directly or indirectly from use of its products, their transportation, their repair, or from any other cause. Acceptance of the manufacturer's product constitutes agreement to the terms of this warranty and further that the manufacturer shall have no liability for any special or consequential damages.

This Warranty is in lieu of all warranties express or implied.

Fill in the following information, attach a copy of your sales receipt or invoice and file in a safe place.

Date of purchase: _____/_____/_____

Name& model# _____

Serial #: _____

Check out these other back-saving tools made by Paragon Pro.

DOORMINATOR™ DOOR HANDLER



Model 3070

Install and remove heavy, awkward doors: 4' wide, 7' tall, up to 160 lbs. Fully adjustable levers allow for perfect alignment and pain free installations. No need to hire extra help, one person installations saves you money!



The Troll® Material Handling Cart

Model 1814

Model 1361

TROLL® Carts Model 1361 or 1814 are the most versatile carts you will find. Convert to a flatbed or use upright - either way store or transport up to 4,000 lbs. of material. The handles store onboard - fold it up to save space or easily transport to another job site. Use to move/store: lumber, tools, ducts, auto parts, machinery, and more. Check out the Troll Bridge for more versatility!



Model 2722



Two TROLL® Carts Model 1361 and the TROLL® Bridge Model 2722 turn into a super sized cart when put together! This is an economical way to add versatility to your existing carts without having to buy a whole other unit.

This product contains trace amounts of the following items which are known to cause
These chemicals are not hazardous under product's intended use.
Please review CAS# for more information.

Chemical	Hazard	CAS#	% By Weight
Arsenic	Cancer	7440-38-2	Trace
Cadmium	Developmental	7440-43-9	Trace
Chromium	Cancer, Developmental	7440-47-3	Trace
Ethylbenzene	Cancer	100-41-4	Trace
Lead	Cancer	7439-92-1	Trace
Methanol	Developmental	67-56-1	Trace
Methylene Chloride (Dichloromethane)	Cancer	75-09-2	Trace
Nickel	Cancer	7440-02-0	Trace
Propylene glycol monobutyl ether	Cancer	5131-66-8	Trace
Toluene	Developmental	108-88-3	Trace
Hexane	Developmental	110-54-3	Trace



Questions about assembly?

Can't find a part?

Need some other help?

Call us: **PARAGON PRO**
MANUFACTURING SOLUTIONS

1(800)441.0551

1(800)448.0822

We'll get you set up!