

HIGH BACK/DUAL SIDE DOOR WORK PLATFORM - WP-4848-84B-DD

APPROX WEIGHT: 313.42 lbs.
DOES NOT INCLUDE WEIGHT OF POWER OR PACKAGING!!!

*** ANY ADDITIONS, DELETIONS, OR OMISSIONS MUST BE CORRECTED ON THIS DRAWING AS THIS DRAWING WILL BE CONSIDERED ALL INCLUSIVE ***
ALL GRAPHICS PROVIDED ARE FOR REFERENCE ONLY. IF CERTAIN DIMENSIONS ARE CRITICAL PLEASE VERIFY THOSE DIMENSIONS WITH YOUR SALESPERSON

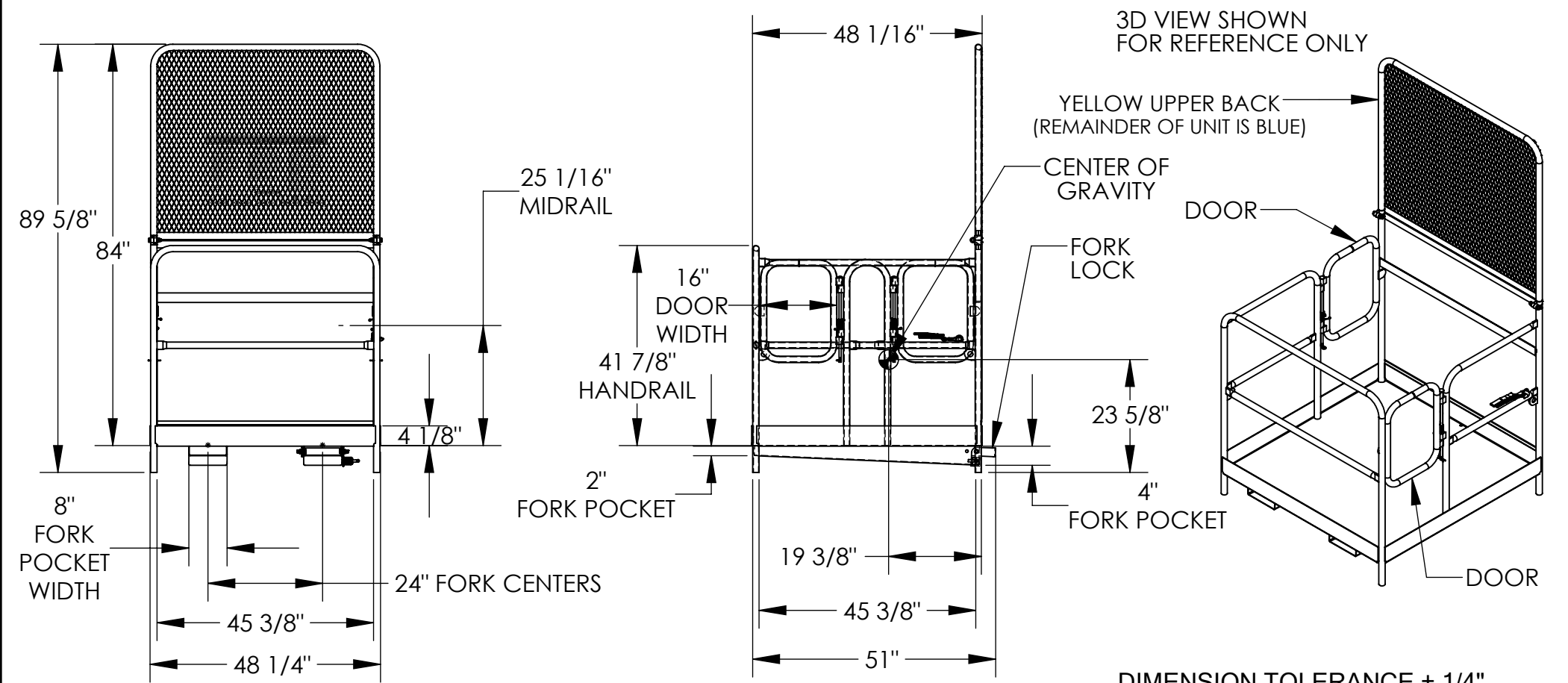

STANDARD FEATURES

- MODEL NUMBER IS WP-4848-84B-DD
- CAPACITY IS 1,000 LBS. (EVENLY DISTRIBUTED LOAD)
- OVERALL WIDTH IS 48 1/4"
- USABLE WIDTH IS 45 3/8"
- OVERALL LENGTH IS 51"
- USABLE LENGTH IS 45 3/8"
- 42" HIGH HANDRAIL WITH 25 1/16" MIDRAIL AND 4 1/8" TOEBOARD
- (2) SELF-CLOSING DOORS SWING IN ONLY (WILL NOT OPEN OUT)
- FORK LOCK IS ROTATED UP BEHIND BACK OF FORK AND LOCKED WITH SPRING LOADED PLUNGER
- 36" LONG STRAP WITH HOOK (NOT SHOWN) MUST ATTACH PLATFORM TO FORK TRUCK
- 84" HIGH EXPANDED MESH BACKING
- USABLE FORK POCKET HEIGHTS: 3 7/8" REAR, 1 7/8" FRONT
- USABLE FORK POCKET WIDTH: 7 3/4"
- MANUFACTURED TO MEET OUR INTERPRETATION OF OSHA STANDARDS
- DURABLE BAKED IN POWDER COATED ERGO BLUE FINISH FRAME AND YELLOW UPPER BACK

APPROX. WEIGHT / LOST LOAD = 281.73
MINIMUM EFFECTIVE THICKNESS = >1"
NEVER EXCEED LOAD CENTER RATING PER FORKTRUCK MANUFACTURERS GUIDELINES.
DO NOT USE THIS FORK TRUCK ATTACHMENT IF LOAD WILL EXCEED FORK TRUCK MANUFACTURER'S LOAD CENTER RATING

SPECIAL FEATURES

NONE

DIMENSION TOLERANCE ± 1/4"

APPROVAL

I, THE UNDERSIGNED, AGREE THAT THE PRODUCT AS REPRESENTED SATISFIES DESIGN AND DIMENSION REQUIREMENTS. I ALSO ACKNOWLEDGE MY DUTY TO CONFIRM PRODUCT AND INSTALLATION COMPLIANCE WITH ALL APPLICABLE FEDERAL, STATE AND LOCAL REGULATIONS AND STANDARDS.

UNITS REQUIRING APPROVAL DRAWINGS OR MODIFIED ARE NON-RETURNABLE

[] As drawn [] As marked

Signed: _____ Date: _____

Printed Name: _____

LEAD TIME WILL START UPON RECEIPT OF SIGNED APPROVAL DRAWING

DISTRIBUTOR'S NAME:		P.O.#
VESTIL MANUFACTURING		X
DRAWN BY:	DATE:	W.O.#
C.WOLF	08/31/06	X
REFERENCE:	SCALE:	SALES:
X	1:30	X
QUOTED LEAD TIME:	QUOTE #	FILE NAME:
X	X	14-007-084