

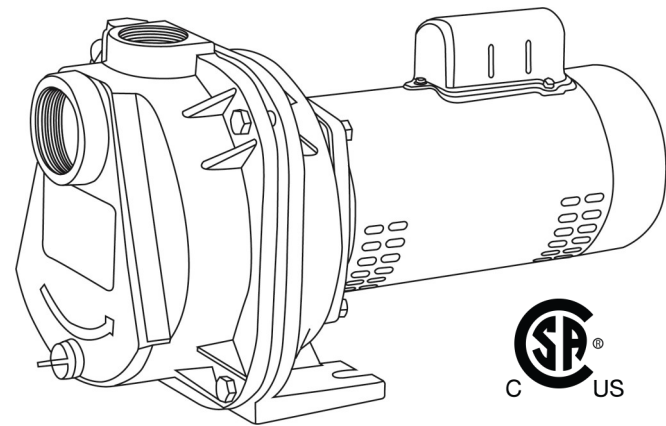

# **OWNER'S MANUAL**

**INSTALLATION AND OPERATION  
INSTRUCTIONS FOR:**

**SHALLOW WELL &  
CONVERTIBLE JET PUMPS  
96210, 96215, 96220**



## Safety Guidelines

Carefully read, understand and follow all safety instructions in this manual.

 This is the safety alert symbol. When you see this symbol, look for one of the following signal words.

**⚠ DANGER** Indicates a hazardous situation which, if not avoided, will result in death or serious injury.

**⚠ CAUTION** Indicates a hazardous situation which, if not avoided, could result in death or serious injury.

**⚠ WARNING** Indicates a hazardous situation which, if not avoided, could result in minor or moderate injury.

**NOTICE** Indicates important information, that if not followed, may cause damage to the equipment.

## Safety Information

Read these warnings carefully. Know the application and limitations of this pump. Failure to follow these warnings could result in serious bodily injury and/or property damage.

**⚠ DANGER** This pump is not submersible. Do not submerge the motor in water or expose to water. Personal injury and/or death could result from electric shock.

**⚠ DANGER** Do not use to pump flammable or explosive liquids such as gasoline, kerosene, fuel oil, etc. Personal injury and / or death could result. Do not use this pump in a flammable or explosive environment. This pump is intended to pump clear water only.

**⚠ DANGER** Do not touch this pump while standing in or walking on wet surfaces until all power is turned off. Do not touch an operating motor. Allow motor to cool before performing service. Failure to follow this warning could result in electric shock.

**⚠ WARNING** Do not run the pump dry. Running the pump dry can damage the internal parts of the pump or cause the pump to overheat which could result in personal injury. Running the pump dry will void the warranty.

**⚠ WARNING** RISK OF ELECTRICAL SHOCK. This pump has not been investigated for use in swimming pool areas.

**NOTICE** This pump is not designed to handle salt water, brine, laundry discharge or any other application which may contain caustic chemicals and/or foreign materials. Pump damage could occur if used in these applications and will void warranty.

## Specifications

Circuit Requirements.....15 Amp

Motor Bearings.....Permanently Lubricated Ball Bearings

Models	HP	Volts	Amps	Hz	Suction	Discharge	Construction	Max. Liquid Temp.
96210	1	115/230	16.4/8.2	60	2"	1-1/2"	Cast Iron	120°F
96215	1-1/2	115/230	17.4/8.7	60	2"	1-1/2"	Cast Iron	120°F
96220	2	115/230	20/10	60	2"	1-1/2"	Cast Iron	120°F

## LIMITED WARRANTY - RESIDENTIAL JET PUMPS:

Superior Pump warrants this product, to the original purchaser, for the initial residence in which it is installed (upon verification that it is installed correctly) to be free from defects in materials and or workmanship for a period of 1 YEAR from the date of purchase. During the time period and subject to the terms and conditions, Superior Pump will repair or replace to the original user or consumer any portion of this product which proves to be defective due to materials or workmanship. At all times Superior Pump shall have and possess the sole right and option to determine whether to repair or replace defective equipment, parts, or components. Superior Pump has the option to inspect any product returned under warranty to confirm that the warranty applies before repair or replacement under warranty is approved. This warranty sets forth Superior Pump sole obligation and purchaser's exclusive remedy for defective product. Return defective product to the place of purchase or postpaid to Superior Pump, Attn: Warranty Dept., 2301 Traffic Street N.E., Minneapolis, MN 55413 for warranty consideration.

## WARRANTY PERIOD - PRODUCTS:

If, within the duration of product use by the original user, this product proves to be defective due to materials or workmanship, the product shall be repaired or replaced at Superior Pump option, subject to the terms and conditions set forth in this warranty statement. Proof of purchase is required for warranty consideration. In the absence of suitable proof of the purchase date, the effective period of this warranty is 12 months from the product's date of manufacture.

## LABOR, ETC. COSTS:

Superior Pump shall IN NO EVENT be responsible or liable for the cost of field labor or other charges incurred by any customer in removing and/or affixing any product, part, or component thereof.

## PRODUCT IMPROVEMENTS:

Superior Pump reserves the right to change or improve its products or any portions thereof without being obligated to provide such a change or improvement for units sold and/or shipped prior to such change or improvement.

## GENERAL TERMS AND CONDITIONS:

This warranty shall not apply to damage due to acts of God, normal wear and tear, normal maintenance services and the parts used in connection with such service, lightning or conditions beyond the control of Superior Pump, nor shall it apply to products which, in the sole judgment of Superior Pump, have been subject to negligence, abuse, accident, misapplication, tampering, alteration; nor due to improper installation, operation, maintenance or storage; nor to excess of recommended maximums as set forth in the instructions. Warranty will be VOID if any of the following conditions are found:

1. Product is used for purposes other than those for which it was designed and manufactured
2. Product not installed in accordance with applicable codes, ordinances, and good trade practices
3. Product connected to voltage other than indicated on nameplate
4. Pump exposed to but not limited to the following: sand, gravel, cement, grease, plaster, mud, tar, oil, gasoline, solvents or other abrasive or corrosive substances
5. Pump has been used for pumping liquids above 120°F
6. Pump allowed to operate dry (liquid supply cut off)

## DISCLAIMER:

Any oral statements about the product made by the seller, Superior Pump, the representatives, or any other parties do not constitute warranties, shall not be relied upon by the user, and are not part of the contract for sale. Seller's and Superior Pump only obligation, and buyer's only remedy, shall be the replacement and/or repair by Superior Pump of the product as described above. NEITHER SELLER NOR SUPERIOR PUMP SHALL BE LIABLE FOR ANY INJURY, LOSS OR DAMAGE, DIRECT, INCIDENTAL OR CONSEQUENTIAL (INCLUDING, BUT NOT LIMITED TO, INCIDENTAL OR CONSEQUENTIAL DAMAGES FOR LOST PROFITS, LOST SALES, INJURY TO PERSON OR PROPERTY, OR ANY OTHER INCIDENTAL OR CONSEQUENTIAL LOSS), ARISING OUT OF THE USE OR THE INABILITY TO USE THE PRODUCT, AND THE USER AGREES THAT NO OTHER REMEDY SHALL BE AVAILABLE TO IT. Before using, the user shall determine the suitability of the product for his/her intended use, and user assumes all risk and liability whatsoever in connection therewith.

THE WARRANTY AND REMEDY DESCRIBED IN THIS LIMITED WARRANTY IS AN EXCLUSIVE WARRANTY AND REMEDY AND IS IN LIEU OF ANY OTHER WARRANTY OR REMEDY, EXPRESSED OR IMPLIED, WHICH OTHER WARRANTIES AND REMEDIES ARE HEREBY EXPRESSLY EXCLUDED, INCLUDING BUT NOT LIMITED TO ANY IMPLIED WARRANTY OF MERCHANTABILITY OR FITNESS FOR A PARTICULAR PURPOSE, TO THE EXTENT EITHER APPLIES TO A PRODUCT SHALL BE LIMITED IN DURATION TO THE PERIODS OF THE EXPRESSED WARRANTIES GIVEN ABOVE.

Some states and countries do not allow the exclusion or limitations on how long an implied warranty lasts or the exclusion or limitation of incidental or consequential damages, so the above exclusion or limitations may not apply to you. This warranty gives you specific legal rights, and you may also have other rights which vary from state to state.



## PUMPING FROM A WELL - DRIVEN WELL POINT

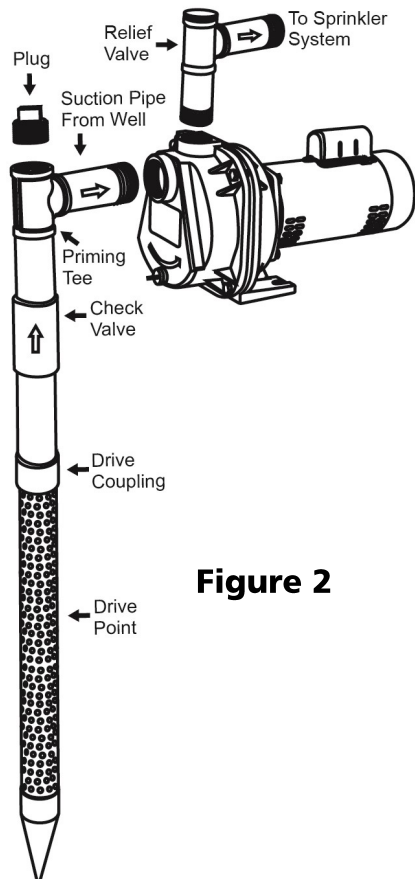

**Figure 2**

1. Drive the point using drive couplings and a drive cap. Do not use regular pipe fittings as the threads may strip out due to the force of driving the point.
2. Position the pump as close as possible to the water source to keep suction lift as low as possible.
3. Install a priming tee with a plug on the suction pipe from the water source as shown in Figure 2. An inline check valve should also be installed on the suction line going to the pump. Install a union or other fitting that will allow the pump to be easily disassembled from the piping for easy servicing. **Make sure teflon tape or pipe joint compound is used on all joints.**
4. Run piping from the discharge tee on the pump housing to the sprinkler system.

## Troubleshooting

PROBLEM	POSSIBLE CAUSES	HOW TO CORRECT
If the pump does not start or run	Pump is not plugged in, switch/breaker is off	Plug pump in or turn on switch/breaker
	Check for blown fuses or tripped circuit breakers or tripped GFCI outlets	Replace fuse, reset breaker, reset GFCI
	Wire connections are loose or wired incorrectly	Tighten connections or re-wire following wiring diagram on page 7
Motor runs hot and thermal overload protector turns pump off	Voltage is too low	Use heavier gauge wire
	Motor is not properly vented	Make sure there is adequate room for air to circulate around the pump
If the pump runs but moves little or no water	Loss of prime	Re-prime if necessary. See page 8
	Air lock in suction line	Make sure horizontal piping between the pump and the well pitches upward towards the pump. Otherwise an airlock may form
	Leak in suction line	Check all connections for leaks. Make sure all connections are air tight.
	Discharge or suction pipes may be clogged or corroded	Remove clog or replace pipes if necessary
	Distance from the pump to the water is greater than 25 feet	Change to a deep well application
	Intake screen/foot valve is obstructed	Clean or replace if necessary
	Foot valve or check valve is stuck in the closed position	Inspect, repair or replace if necessary
	Foot valve or check valve is installed backwards	Make sure valve is installed in the correct direction of flow
	Worn, damaged or clogged pump parts (Injector, impeller, diffuser, seal, etc.)	Inspect for wear, damage or clog and clean or replace if necessary
	Foot valve is buried in sand or mud	Raise above surface bottom
	Water level in the well is too low	Lower suction pipe or convert to deep well application
	Well is "dry" or has slow recovery	Move location of well
	Pipes are frozen	Thaw pipes, heat pump house or bury pipes below frost line

**⚠ WARNING**

Never run your pump dry. Damage to the internal parts of the pump could result and void the warranty.

**⚠ WARNING**

Never run the pump with the discharge side of the pump closed. The water inside the pump may boil and reach dangerous pressures which may result in severe burns if handled.

**How to prime your jet pump**

1. Remove the prime plug on the pump and fill the pump and all piping with water. Use a funnel if necessary. If you installed a priming tee on the suction side, remove the plug and fill all piping.
2. Replace all plugs making sure all joints are air and water tight. Use Teflon tape or pipe joint compound.
3. Open a faucet to vent the system of air.
4. Turn on the pump. Water should be pumped within 1-2 minutes. If there is no water being pumped after 2 minutes, turn the pump off and repeat the above steps. NOTE: if you are pumping from a depth of 20' or more it may take several attempts to prime your pump.
5. Once the pump is moving water, let the system operate for a few minutes to flush all air out of the pipes.
6. Once primed test the sprinkler system

**Prime Plug**

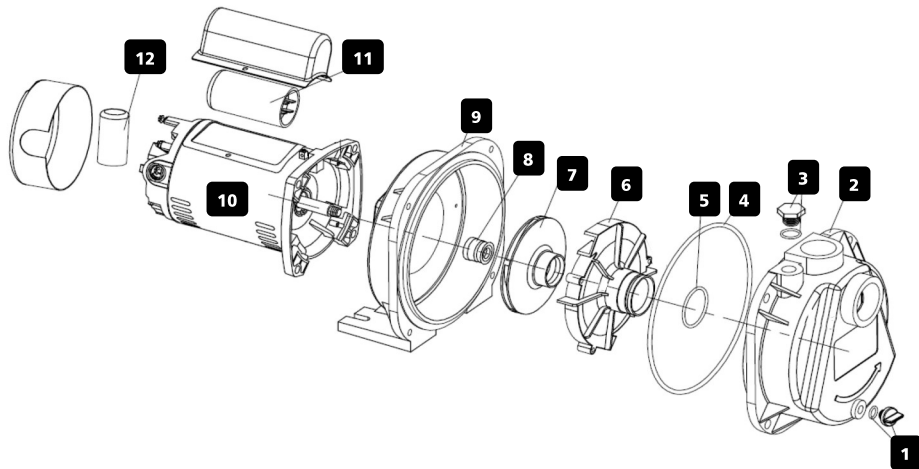

Ref#	Description	96210	96215	96220
1	Drain Plug	*	*	*
2	Pump housing	n/a	n/a	n/a
3	Priming plug			
4	O-Ring large			
5	O-Ring small			
6	Diffuser			
7	Impeller			
8	Shaft seal			
9	Seal plate	n/a	n/a	n/a
10	Motor	*	*	*
11	Starting capacitor	n/a	n/a	n/a
12	Running capacitor	n/a	n/a	n/a

\*If motor fails, replace entire pump.

**PUMPING FROM A WELL - CASED WELL POINT**

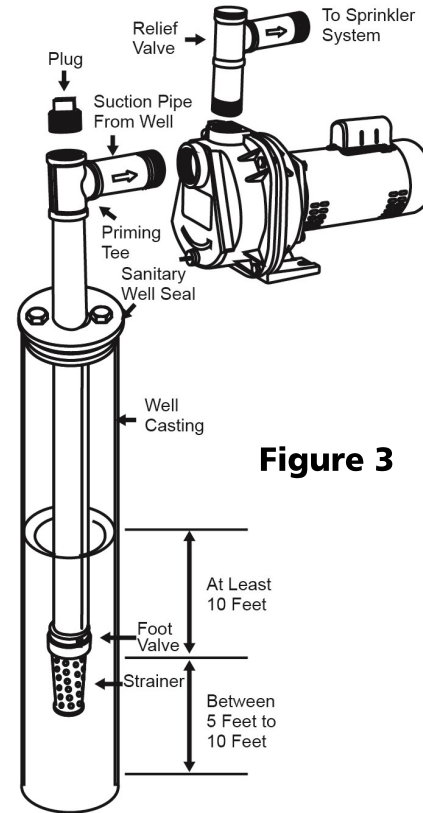

**Figure 3**

1. Install a foot valve with strainer on the first section of pipe and lower it into the well.
2. Add enough pipe until the foot valve is about 10 feet below the water level. Make sure the foot valve does not rest on the bottom of the well.
3. Long lengths of pipe or hose and use of many fittings will reduce pump flow. Use the smallest number of fittings and shortest possible length of pipe or hose as possible.
4. Install a priming tee with a plug on the suction pipe from the water source as shown in Figure 3. Install a union to allow the pump to be easily disassembled from the piping for easy servicing. **Make sure Teflon tape or pipe joint compound is used on all joints. The suction pipe should be at least 1 1/4"**
5. Install a well seal to prevent debris and other contaminants from entering the well.

6. Run piping from the discharge tee on the pump housing to the sprinkler system.

## Electrical Connections

**⚠ CAUTION** Risk Of Fire. Never connect a 230 volt line to a 115 volt motor.

Check Voltage Setting Switch

**TURN OFF POWER SUPPLY TO PUMP!!**

**NOTE:** The voltage switch is factory set for 230 volt service. If you have 230 volt service do not change the voltage switch (Figure 4 & 5).

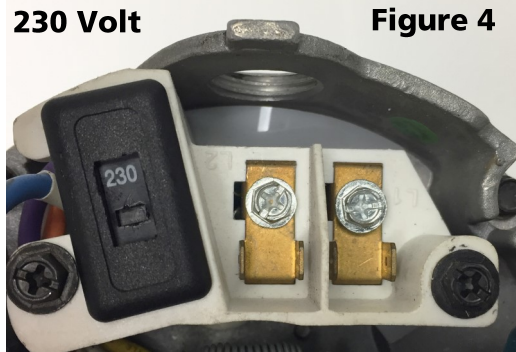

The voltage switch is factory set for 230 volt service.

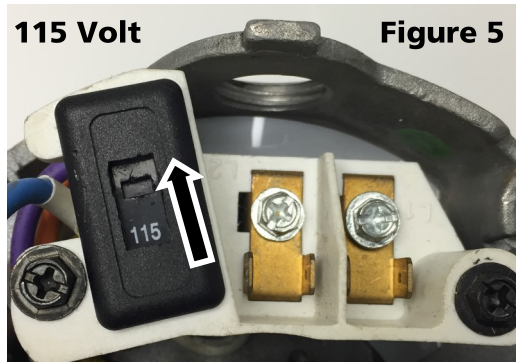

To change to 115 volt operation slide the voltage switch to "115" volts

Use the chart below to determine what gauge wire you should be used in your installation.

115 Volt			Distance in Feet from Motor to Power Supply		
HP	Volts	Amps	Wire Size (AWG)		
			0-50'	51-100'	101-200'
1	115	16.4	12	10	8
1-1/2	115	17.4	12	10	8
2	115	20	10	8	8

230 Volt			Distance in Feet from Motor to Power Supply		
HP	Volts	Amps	Wire Size (AWG)		
			0-50'	51-100'	101-200'
1	230	8.2	14	14	12
1-1/2	230	8.7	14	14	12
2	230	10	14	12	12

## Electrical Connections (continued)

### 230 VOLT CONNECTION

1. Connect the ground wire from the power source to the ground terminal on the pump. Make sure the ground from the power source is connected to a grounded terminal in the service panel, a metal underground water pipe, a metal well casing, or a grounding rod.
2. Connect one hot wire (usually black or red) from the power source to one of the line terminals on the pump. It doesn't matter which one. Follow wiring diagram in Figure 5.
3. Connect the other hot wire from the power source to the other line terminals on the pump.

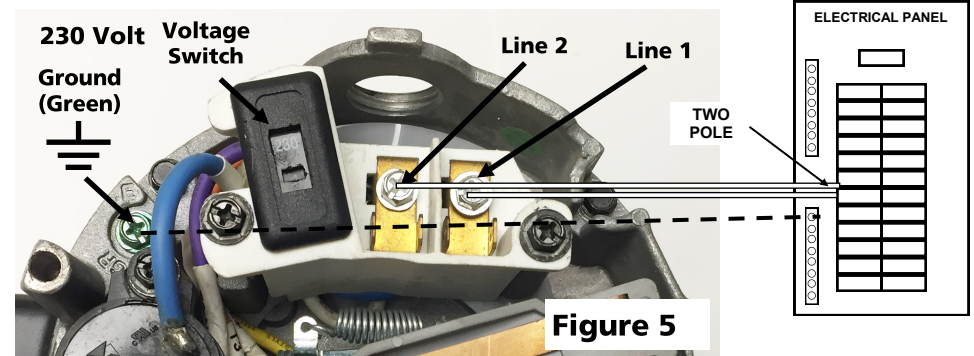

### 115 VOLT CONNECTION

1. Connect the ground wire from the power source to the ground terminal on the pressure switch. Make sure the ground from the power source is connected to a grounded terminal in the service panel, a metal underground water pipe, a metal well casing, or a grounding rod.
2. Connect one hot wire (usually black or red) from the power source to one of the line terminals on the pump. It doesn't matter which one. Follow wiring diagram in Figure 6.
3. Connect the white (neutral) wire from the power source to the other line terminal on the pump.

