

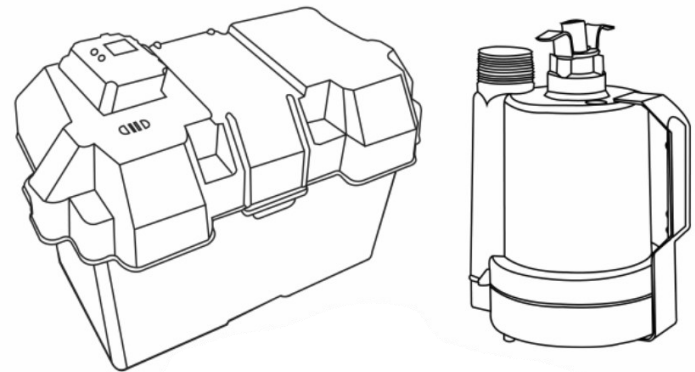

# **OWNER'S MANUAL**

## **INSTALLATION AND OPERATION INSTRUCTIONS FOR 12 VOLT BATTERY BACK-UP SYSTEM Models: 92900 & 92910**





**SUPERIORPUMP.COM**  
**1-800-495-9278**

## Safety Guidelines

Carefully read, understand and follow all safety instructions in this manual.

 This is the safety alert symbol. When you see this symbol, look for one of the following signal words.

 **DANGER** Indicates a hazardous situation which, if not avoided, will result in death or serious injury.

 **CAUTION** Indicates a hazardous situation which, if not avoided, could result in death or serious injury.

 **WARNING** Indicates a hazardous situation which, if not avoided, could result in minor or moderate injury.

## Safety Information

Read these warnings carefully. Know the application and limitations of this pump. Failure to follow these warnings could result in serious bodily injury and/or property damage.

 **DANGER** RISK OF ELECTRICAL SHOCK. Disconnect and lockout power supply before removing old pump or installing or servicing this pump.

 **DANGER** This pump is designed to pump clear water. Do not use this pump to pump chemicals, flammable liquids, sewage or corrosive liquids. You could injure yourself and the pump will fail. Pumping these types of liquids voids the warranty.

 **DANGER** This system is designed for indoor use only. Keep all electrical connections away from wet and moist environments. Wet connections can cause electrical shock resulting in personal injury. Do not plug in or unplug the power supply cord(s) while standing on a wet floor or in water. If the floor is wet, disconnect power to the pump before walking on floor.

 **WARNING** Battery acid is corrosive. Do not spill on skin, clothing, or parts of this system. Wear gloves and eye protection when handling the battery.

 **WARNING** **DO NOT** use the power cord to install or carry the pump. The cord may pull apart exposing bare wires which could cause a fire or electrical shock. Use the handle supplied with the pump for installing and transporting the pump.

 **WARNING** Do not run the pump dry. This pump relies on water for cooling and lubrication. Running the pump dry can cause the pump to overheat and the possibility of burns to anyone that handles the pump. Running the pump dry will void the warranty.

 **WARNING** This system is designed to be used in a residential backup sump pump application only. It is not designed to be used as a primary sump pump.

 **WARNING** Make sure the sump basin is clear of rocks, sand, mud & debris. Debris can damage or clog the pump which could result in flooding.

 **WARNING** This product can expose you to chemicals including vinyl chloride which is known to the state of California to cause cancer. For more information go to [www.P65Warnings.ca.gov](http://www.P65Warnings.ca.gov)

 **CAUTION** Do not use this pump for potable/drinking water. Use only in applications for which the pump is designed for.

## LIMITED WARRANTY - BATTERY BACKUP PUMPS:

Manufacturer warrants the products specified in this warranty to be free from defects in material or workmanship for one (1) year from date of purchase. During the time period and subject to the terms and conditions, the manufacturer will repair or replace to the original user or consumer any portion of this product which proves to be defective due to materials or workmanship. At all times the manufacturer shall have and possess the sole right and option to determine whether to repair or replace defective equipment, parts, or components. The manufacturer has the option to inspect any product returned under warranty to confirm that the warranty applies before repair or replacement under warranty is approved. This warranty sets forth the manufacturer's sole obligation and purchaser's exclusive remedy for defective product. Return defective product to the place of purchase for warranty consideration.

## WARRANTY PERIOD - PRODUCTS:

If, within the duration of product use by the original user, this product proves to be defective due to materials or workmanship, the product shall be repaired or replaced at the manufacturer's option, subject to the terms and conditions set forth in this warranty statement. Proof of purchase is required for warranty consideration. In the absence of suitable proof of the purchase date, the effective period of this warranty is 12 months from the product's date of manufacture.

## LABOR, ETC. COSTS:

The manufacturer shall **IN NO EVENT** be responsible or liable for the cost of field labor or other charges incurred by any customer in removing and/or affixing any product, part, or component thereof.

## PRODUCT IMPROVEMENTS:

The manufacturer reserves the right to change or improve its products or any portions thereof without being obligated to provide such a change or improvement for units sold and/or shipped prior to such change or improvement.

## GENERAL TERMS AND CONDITIONS:

This warranty shall not apply to damage due to acts of God, normal wear and tear, normal maintenance services and the parts used in connection with such service, lightning or conditions beyond the control of the manufacturer, nor shall it apply to products which, in the sole judgment of the manufacturer, have been subject to negligence, abuse, accident, misapplication, tampering, alteration; nor due to improper installation, operation, maintenance or storage; nor to excess of recommended maximums as set forth in the instructions. Warranty will be VOID if any of the following conditions are found:

1. Product is used for purposes other than those for which it was designed and manufactured
2. Product not installed in accordance with applicable codes, ordinances, and good trade practices
3. Product connected to voltage other than indicated on nameplate or labels
4. Pump exposed to but not limited to the following: sand, gravel, cement, grease, plaster, mud, tar, oil, gasoline, solvents or other abrasive or corrosive substances
5. Pump has been used for pumping liquids above 120°F
6. Pump allowed to operate dry (liquid supply cut off)

## DISCLAIMER:

Any oral statements about the product made by the seller, the manufacturer, the representatives, or any other parties do not constitute warranties, shall not be relied upon by the user, and are not part of the contract for sale. Seller's and the manufacturers only obligation, and buyer's only remedy, shall be the replacement and/or repair by the manufacturer of the product as described above. NEITHER SELLER NOR THE MANUFACTURER SHALL BE LIABLE FOR ANY INJURY, LOSS OR DAMAGE, DIRECT, INCIDENTAL OR CONSEQUENTIAL (INCLUDING, BUT NOT LIMITED TO, INCIDENTAL OR CONSEQUENTIAL DAMAGES FOR LOST PROFITS, LOST SALES, INJURY TO PERSON OR PROPERTY, OR ANY OTHER INCIDENTAL OR CONSEQUENTIAL LOSS), ARISING OUT OF THE USE OR THE INABILITY TO USE THE PRODUCT, AND THE USER AGREES THAT NO OTHER REMEDY SHALL BE AVAILABLE TO IT. Before using, the user shall determine the suitability of the product for his/her intended use, and user assumes all risk and liability whatsoever in connection therewith.

**THE WARRANTY AND REMEDY DESCRIBED IN THIS LIMITED WARRANTY IS AN EXCLUSIVE WARRANTY AND REMEDY AND IS IN LIEU OF ANY OTHER WARRANTY OR REMEDY, EXPRESSED OR IMPLIED, WHICH OTHER WARRANTIES AND REMEDIES ARE HEREBY EXPRESSLY EXCLUDED, INCLUDING BUT NOT LIMITED TO ANY IMPLIED WARRANTY OF MERCHANTABILITY OR FITNESS FOR A PARTICULAR PURPOSE, TO THE EXTENT EITHER APPLIES TO A PRODUCT SHALL BE LIMITED IN DURATION TO THE PERIODS OF THE EXPRESSED WARRANTIES GIVEN ABOVE.**

Some states and countries do not allow the exclusion or limitations on how long an implied warranty lasts or the exclusion or limitation of incidental or consequential damages, so the above exclusion or limitations may not apply to you. This warranty gives you specific legal rights, and you may also have other rights which vary from state to state.

## Replacement Parts

For parts assistance, please call 1-800-495-9278

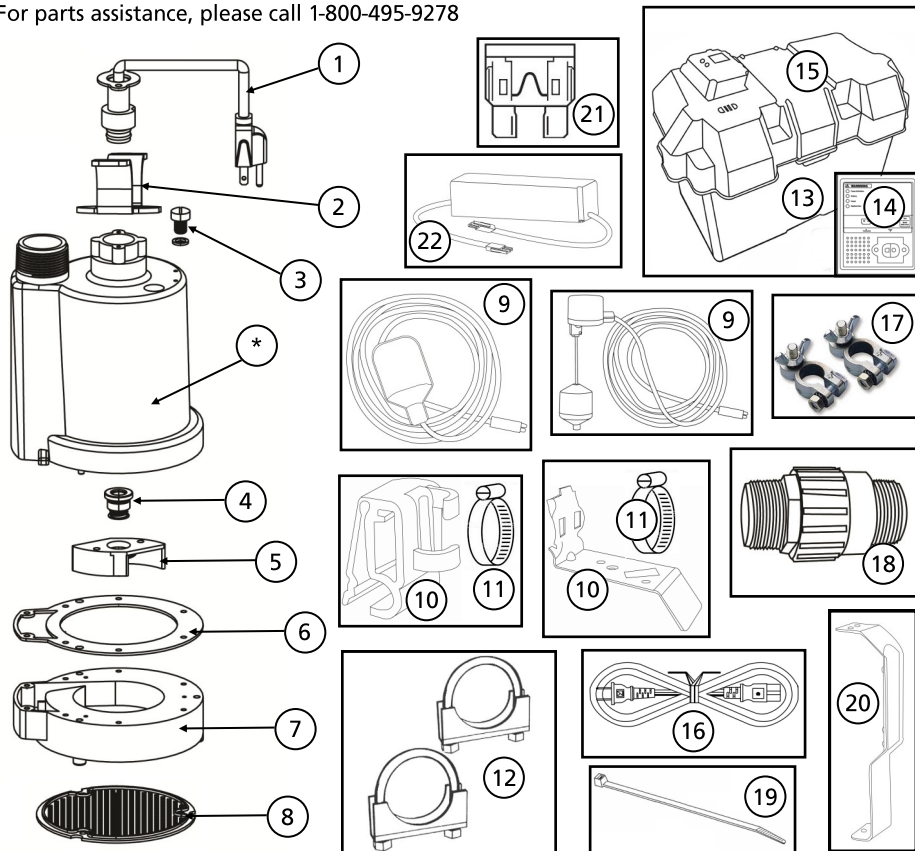

Ref #	Description	Part for Model #	
		92900	92910
1	Power Cord - Pump	99158	99158
2	Pump Handle	99050	99050
3	Plug with O-ring	99056	99056
4	Shaft Seal	99057	99057
5	Impeller	99060	99060
6	Gasket	99062	99062
7	Volute/Base	99067	99067
8	Intake Screen	99073	99073
9	Float Switch	92050	99091
10	Float Switch Mounting Bracket	99180	99195
11	Stainless Steel Hose Clamps	99183	99183
12	U-Bolt & Saddle Clamp Assembly - 2 sets	99462	99462
13	Battery Box	99459	99459
14	Control Panel	99455	99455
15	Battery Box Cover with Control Panel	99456	99456
16	Power Cord - Control Panel	99452	99452
17	Battery Terminals (+ & -)	99460	99460
18	Universal Check Valve	99505	99505
19	Cable Ties	Purchase Locally	Purchase Locally
20	Pump Mounting Bracket	99461	99461
21	30 Amp Fuse (Blade Type - Automotive)	Purchase Locally	Purchase Locally
22	2 Amp Charger	99454	99454

## Battery Selection

This system is designed to work with 12 volt, lead-acid, deep cycle marine/RV and AGM batteries. Either a flooded cell (serviceable or maintenance free) or sealed AGM battery are acceptable. It is recommended to choose a battery with a minimum 40 amp-hour rating. The higher the amp-hour rating on the battery, the longer the pump will run on battery power. Avoid using automobile batteries as these types of batteries are not intended to be charged/discharged for extended periods of time.

The battery case will accommodate group 24 or 27 batteries.

During prolonged periods of power failure or in an emergency situation, your automobile battery may be used. Make sure to replace the deep cycle battery as soon as possible as the automobile battery will be quickly damaged by the continuous charge/discharge cycles.

## General Information

This battery back-up system is not intended to replace or be used without a primary sump pump. It is intended to provide temporary back up during power failures or malfunctions associated with the primary pump.

## Carbon Monoxide (CO) Detectors

All backup pump systems that use lead acid batteries, regardless of brand, give off gaseous by-products when the battery is charging. Some of these by-products can cause a carbon monoxide (CO) detector to give a false alarm. When installing this system, position the battery as far away from the CO detector as possible. **DO NOT** move or remove CO detectors from their original location. Always follow the instructions that accompany your CO detector.

If your CO detector alarm sounds, take the following actions.

1. Take immediate action for personal safety as outlined in the CO detector manual.
2. Contact the appropriate utility agency to determine if the CO is coming from your furnace, water heater or other appliance that uses natural gas.

If it's determined that a charging battery is causing the CO detector to activate, contact the battery manufacturer for recommendations on how to alleviate the problem.

## Installation

**⚠ WARNING** Always disconnect the power source before attempting to install, service or perform maintenance on the pump (primary or backup).

Failure to do so may result in fatal electric shock. If required, a qualified electrician must install all wiring.

**⚠ WARNING** This system is designed for indoor use only. Do not install outdoors or where the electronics could be exposed to wet conditions.

## TOOLS & MATERIALS REQUIRED

- Pencil or marker
- Socket wrench with 10mm socket, 10mm nut driver or adjustable wrench
- Hacksaw
- Pipe cleaner & cement
- Pliers
- Slip joint pliers
- Tape measure
- Deep cycle battery (see battery selection section)

**NOTE: Install this system when the primary pump will not be required.**

1. Start by finding the water level at which your primary pump turns on. Mark this point on the discharge pipe with a pencil or marker.
2. **NOTE:** If your existing discharge pipe is metal or flexible tubing it will need to be replaced with Schedule 40 PVC or ABS pipe.
3. Drain as much excess water from the sump basin as possible.
4. When the basin has been drained, turn off the power to the outlet / pump to avoid the risk of electrical shock.
5. Before removing the primary pump, make sure the discharge pipe is properly supported to prevent it from collapsing.
6. If your installation uses a flexible pipe coupling with hose clamps, simply disconnect the coupling and remove the pump. If a flexible coupling is not used, cut the pipe using a hacksaw as close to the floor level as possible and remove the pump from the basin. **NOTE: BE PREPARED FOR WATER TO LEAK FROM THE PIPE WHEN CUTTING.** Keep tools and components of this system away from the work area when cutting pipe. If any components get wet, make sure they are dry before installing.
7. If your primary pump does not have a check valve in or near the pump discharge, install one at this time (sold separately). It is necessary to have a check valve installed on both the back up pump and on the primary pump. **NOTE: The primary pump check valve must be located below the junction of where the back up and primary piping meet.** This is to prevent backflow from the back-up pump when it is running.

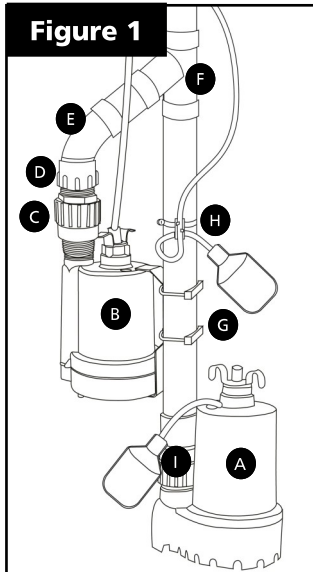

- d - Primary Pump (sold separately)
- e - Back up Pump
- f - Check Valve
- g - Female Adapter
- h - 45° Street Elbow
- i - Wye fitting
- j - U-Bolts & Clamps
- k - Float Switch Clamp
- l - Primary pump check valve\* (sold separately)

**\*The primary pump check valve must be located below the junction of where the back up and primary piping meet.**

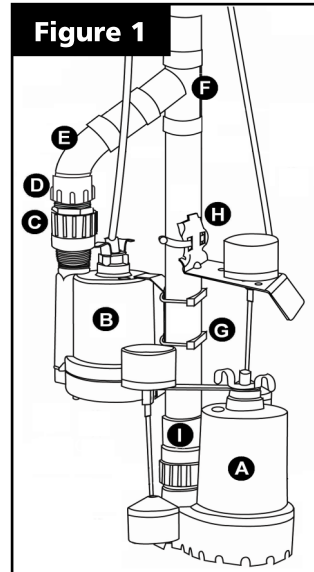

8. Attach the back-up pump to the primary discharge pipe using two U-Bolts, Clamps, washers and nuts (G). Position the backup pump so it is located near the water level that was marked in Step 1. Tighten the nuts using a 10mm socket or adjustable wrench. **DO NOT** over tighten. **NOTE:** Make sure the U-bolts are properly seated in the recessed channels on the pump mounting bracket. (The pump mounting bracket comes pre-attached to the pump).

## Performances

Height and/or piping restriction will reduce the pump output performance. See the performance chart below to ensure the pump will work in your application. Whenever possible use the same size or larger pipe as the pump discharge for optimum performance. Reducing the pipe size will not harm your pump, it will just reduce the output.

Output in gallons per minute at listed discharge height above pumping level*					
Model #	0'	5'	10'	15'	20'
92900 / 92910	23	22	18	13	8

\*Performance ratings are based off using a fully charged, 12 volt, deep cycle AGM battery with a 100 Ah rating. Performances may vary depending on size & type of battery used. Performance will decrease as the battery discharges.

## Specifications

Model	92900	92910
Volts	12 volt DC	12 volt DC
Amps	12 Amps	12 Amps
Discharge Size	1-1/4" & 1-1/2" NPT*	1-1/4" & 1-1/2" NPT*
Max. Solids Handling	1/8"	1/8"
Liquid Temperature Range	32°F - 120°F	32°F - 120°F
Pump Cord Length	10'	10'
Switch Type	Tethered	Vertical
Pump Housing Construction	Thermoplastic	Thermoplastic
Pump Base Construction	Thermoplastic	Thermoplastic
Impeller Material	Thermoplastic	Thermoplastic
Motor Shaft	Stainless Steel	Stainless Steel
Mechanical Shaft Seal	Carbon/Ceramic/Stainless Steel	Carbon/Ceramic/Stainless Steel
Fasteners	Stainless Steel	Stainless Steel
Shut off head	21'	21'
Max. PSI	9.0	9.0
Battery Requirement	12 volt Deep Cycle	12 volt Deep Cycle
Battery Charger	2 Amp	2 Amp
Low Voltage Cutoff	≈10.8 Volts	≈10.8 Volts

\*1-1/2" NPT size when using included universal check valve

## Troubleshooting

Problem	Possible Causes	How to Correct
Pump won't run.	Loose, corroded or reversed wire connections	Tighten, clean or reconnect if necessary
	Discharged battery	Charge battery
	Defective battery	Replace battery
	Blown fuse	Replace with 30 amp fuse
	Float switch is stuck	Position float so it moves freely
	Battery is discharged below 10.8 volts	Fully charge battery
Pump cycles too often	Float switch positioned improperly	Reposition float switch
	Defective or missing check valve	Install or replace check valve
Pump runs but moves little or no water	Low or discharged battery	Fully charge battery
	Obstruction in pipe or frozen pipe.	Clear obstruction or thaw pipe.
	Discharge pipe height/length exceeds the capacity of the pump	Check performance section for capacity of this pump
	Defective check valve	Replace Check Valve if necessary

- Thread the check valve (C) onto the discharge of the back-up pump
- Plumb the back-up pump to the primary pump piping using a 1-1/2" Female Adapter (D), 45° Street Elbow (E) and a Wye fitting (F). It is highly recommended to do a "dry fit" before permanently gluing the pipe and fittings together. Place the assembly in the basin to make sure that it fits and that the primary float switch operates freely before permanently gluing the pipe and fittings together.
- Remove the assembly from the basin and glue all fittings.
- Secure the float switch to the discharge pipe using the provided mounting clamp and hose clamp. See figure 2 below for proper installation. DO NOT fully tighten the clamp at this time. Leave it a bit loose so you can adjust the position of the float in the next steps.
- After the float switch has been attached to the discharge pipe, place the entire assembly in the basin. Make sure the primary pump float switch will operate freely and not contact the sides of the basin. Connect the pump assembly to the discharge pipe. Use either a flexible coupling with clamps or a solvent weld PVC or ABS coupling.

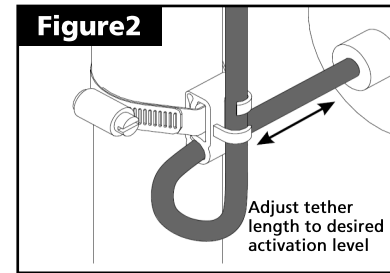

TETHERED SWITCH INSTALLATION

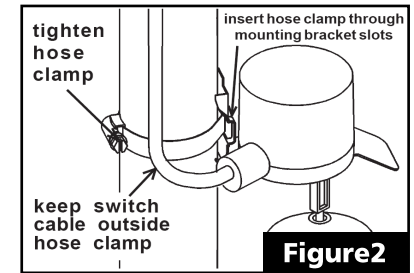

VERTICAL SWITCH INSTALLATION

### Tethered Switch Installation

Adjust the tether length of the float switch so the back up pump will turn on when the water level rises above the start level of the primary pump. Make sure the "on" level does not exceed the top of the basin. It is recommended to keep at least a 2" clearance from the top of the basin. Position the float so that it will operate freely and not contact the sides of the basin or the primary pump. Once positioned properly, completely tighten the float switch clamp.

### Vertical Switch Installation

Position the Vertical Float Switch on the discharge pipe so it will turn on when the water level rises above the start level of the primary pump. Make sure the "on" level does not exceed the top of the basin. It is recommended to keep at least a 2" clearance from the top of the basin. You can adjust the "off" level of the vertical float by moving the grommet up or down on the vertical float rod. Once positioned properly, completely tighten the float switch clamp.

**NOTE:** There are many different options for assembling this unit. The instructions above represent one of the most common installations. Your installation may vary. If you have a very shallow basin, mounting the back-up pump above the primary pump may not be feasible. You may also position the pump on bottom of the basin. Make sure the back up pump is positioned so that it won't interfere with the primary pump operation. If you have any questions about your particular installation, please feel free to contact us at 1-800-495-9278.

## Wiring & Electrical Connections

1. If necessary, attach the provided battery terminals to the battery (battery is sold separately). Many deep cycle marine & AGM batteries come with a threaded post terminal built in. **NOTE:** The provided battery terminals are labeled (+) positive and (-) negative. Make sure the terminals are connected to the proper terminal on the battery. Place the battery in the battery box.
2. Connect the battery lead wires from the control panel to the corresponding terminals on the battery. Connect the red (+) positive lead to the positive battery terminal and securely tighten the nut. Connect the black (-) negative lead to the negative battery terminal and securely tighten the nut. Secure the battery box cover to the lower case.
3. Connect the backup pump power cord to the corresponding receptacle on the control panel. Make sure it is fully seated in the receptacle.
4. Connect the backup pump float switch plug to the corresponding receptacle on the control panel. Make sure it is fully seated in the receptacle.
5. Connect the control panel power cord into the side of the control panel. Make sure it is fully seated in the receptacle. Plug the power cord into the outlet.
6. Test the float switch and pump by lifting and holding the float. The alarm will sound and the "PUMP ACTIVATION" light on the control panel will illuminate. The "SYSTEM" light will also change from green to red. The pump should start after lifting the float. If it does not run, check your connections and retry.
7. Test the "MUTE" button when the alarm is sounding. Press once to mute the alarm, or press and hold for 5 seconds to silence the alarm. **NOTE:** When silencing the alarm press and hold the "MUTE/SILENCE" button until it beeps (approximately 5-6 seconds). This will indicate that the alarm is silenced. To re-activate the alarm, press and hold the TEST/RESET button until it beeps.
8. Secure the float switch and pump cords to the discharge pipe using the provided zip ties. This is to prevent the cords from obstructing the float switches during operation.

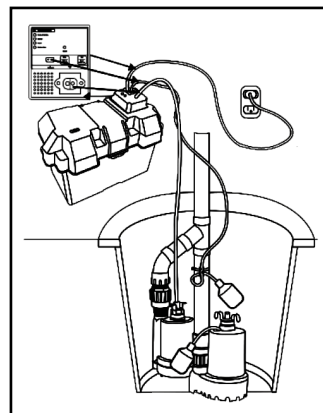
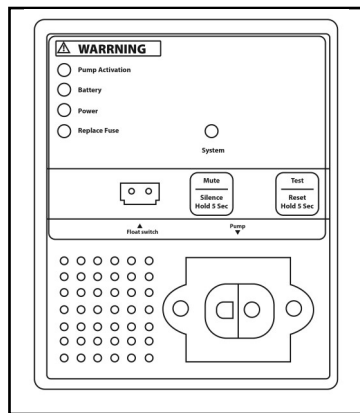

## Installation - Testing installation

1. Once your installation and wiring connections are complete, unplug or disconnect the power to the primary pump.
2. Fill the basin using buckets or a hose. Observe the float switches to make sure they are positioned properly when the basin is filling. Fill the basin until the backup float activates the alarm. The pump should start and drain the basin.
3. Make any necessary adjustments to the float(s) and/or pumps at this time.

## Operation

1. When the power fails or when there is a problem with the primary pump, the back-up pump will automatically start. The back up pump will operate for many hours intermittently on battery power. During prolonged periods of power outage the pump may stop pumping when the battery voltage drops below 10.8 volts. When this happens the an alarm will sound signaling that the voltage is too low to operate the pump.
2. This unit is equipped with a 2 amp charger. It will charge a discharged battery at a rate of 2 Ah (Amp hours). Once the battery reaches a full charge, the charger will gradually reduce the charge rate. It will also maintain a charged battery by periodically checking the voltage of the battery.
3. The charger is equipped with over charge protection. It will not let the battery become over charged.

## WARNING LIGHTS & CONTROLS

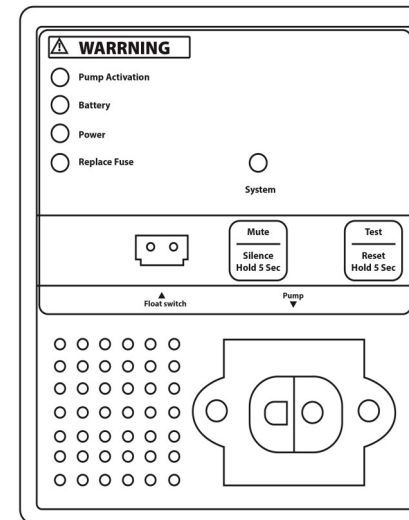

**System** - When the system is operating normally without any warnings or notifications, this light will illuminate solid green.

**Pump Activation** - This light will illuminate and the alarm will sound when the back up pump has activated. Press and hold the test/reset for 5 seconds (until it beeps) to re-set.

**Battery** - This light will illuminate and the alarm will sound when the battery voltage drops below 10.8 volts. Press and hold the Test/Reset button (until it beeps) for 5 seconds to reset.

**Power** - This light will illuminate and the alarm will sound when the AC power to the control panel is interrupted or disconnected. This would indicate a loose or disconnected power cord, a power outage, or a blown fuse/circuit breaker or tripped GFCI outlet. Press and hold Test/Reset button for 5 seconds (until it beeps) to reset.

**Replace Fuse** - This light will illuminate and the alarm will sound when the fuse is blown and needs to be replaced. Press and hold Test/Reset button for 5 seconds (until it beeps) to reset.

**Mute / Silence** - Press this button once to mute the alarm. The alarm will remain muted until another warning is detected. Press and hold this button for 5 seconds until it beeps to permanently silence the alarm. To reactivate the alarm, press and hold the Test/Reset button for 5 seconds (until it beeps).

**Test/Reset** - Press this button once to test the status of the control panel and operation of the back up pump. The green light will flash and the pump will operate for 5 seconds and turn off. If any problems are detected, the alarm will sound and the corresponding light will illuminate. Press and hold this button for 5 seconds (until it beeps) to reset all alarm & warning notifications.