

# Installation Instructions

## DBV2500 & DBV3500 Dump Body Vibrator

### CAUTION

Read and follow these instructions for proper installation of a TruckSTAR dump body vibrator model DBV2500 OR DBV3500.

1. When selecting the vibrator's mounting location always follow safe working procedures including, but not limited to: Engaging parking brake, chocking truck tires in both directions, locking dump body safety prop in place and turning off truck engine.
2. The vibrator should be mounted as close to  $\frac{1}{4}$  the body's length from the front of the body as possible. It should be centered between the body's long members/sills.
3. Check for proper clearance between the vibrator and: hoist, truck frame, oil tanks, air tanks, fuel tanks etc.
4. The dump body will need to be reinforced to accept the force of the vibrator. For bodies with traditional channel, I-beam or tubing cross members select and cut a 4" to 6" wide channel long enough to cover the length of three cross members (typically 36"-38") as shown in Figure "A". Position the channel perpendicular across the three cross members and stitch weld in place. Locate the supplied (threaded) vibrator plate over the middle of the three cross members and weld in place. It should run the same direction of the mounting channel

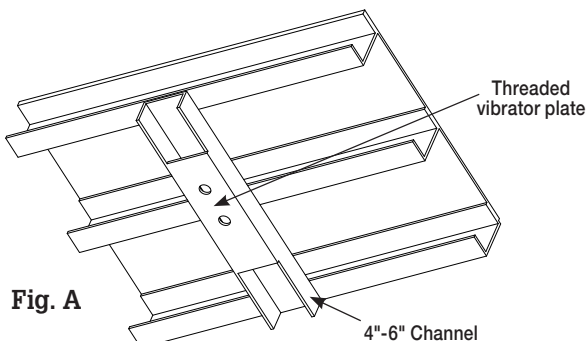
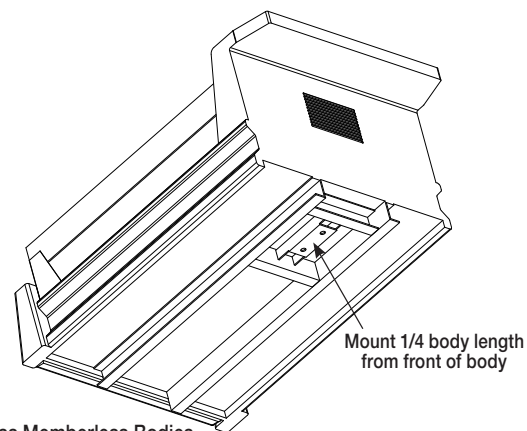

**Fig. A**

For Bodies with Cross Members



5. Place vibrator on threaded mounting plate. On one side of vibrator insert bolt and retainer lock, and apply medium/strong thread locker to bolt and tighten. Inspect vibrator mounting plate for any warping from welding. If there is any warping, shim (over shim a little) the other mounting foot so mounting surface and feet are flush. Note: Failure to mount vibrator on flat surface can crack the housing and/or affect vibrator performance. Insert second bolt and retainer lock, and apply medium/strong thread locker to bolt and tighten. Torque mounting bolts to 280 ft. lbs. Note: When vibrator is wired, run for 10+ minutes in 15 seconds on/30 seconds off intervals (Caution! Vibrator will be hot), retighten and torque each



**Fig. B**

For Cross Memberless Bodies

bolt to 280 ft. lbs. Bend both bolt retainer lock tabs (as shown in Fig. "C") to prevent bolts from loosening. Chain vibrator to body for added safety (chain not included).

**6.** Wire vibrator per Figure "C" wiring schematic.

**7.** Install a chassis grounding strap for a more positive ground. Adequate (4) AWG wire and (2) additional terminals have been provided for this purpose.

**8.** Optional Timer Installation: (Figure "D" or Figure "E")

**a.** Push button and timer should be mounted in the cab in a convenient location.

**b.** The operating time (ON time) of the vibrator is preset to 15 seconds for the optional timer.

**c.** To operate: press and release push button. The vibrator will run for 15 seconds and stop. To run the vibrator again wait 30 seconds, then press button again.

**d.** Wire the timer and push button to truck's ignition for secured operation.

### Trouble Shooting Guide

**1.** Vibrator runs slow: Measure motor voltage. If less than 12 volts DC, increase wire size from standard 4 AWG to 2 AWG. **Installations requiring over 50' of wire use 2 AWG wire.**

Inspect motor brushes and change as needed. Brush

life varies with duty cycle.

**2.** Loud, unusual vibrator noise: Make sure vibrator bolts are tight. Inspect mounting plate for cracks. Reinforce mounting plate and weld as needed. If vibrator casting is cracked replace with new parts.

**3.** Vibrator fails to operate: Check vibrator to make sure it is getting power. Check all electrical connections (and ground) for secure corrosion free connections. Vibrator is grounded through its foot. Install grounding strap for a more positive ground. Check cab push button switch, solenoid and circuit breaker for proper operation. Note: 150 Amp circuit breaker requires manual reset. If tripped, reset. Maximum continuous run time is 15 seconds followed by 30 seconds cooling time before operating again.

**Although the vibrator has o-ring seals and the bearings are permanently lubricated, avoid spraying vibrator directly with water and do not pressure wash.**

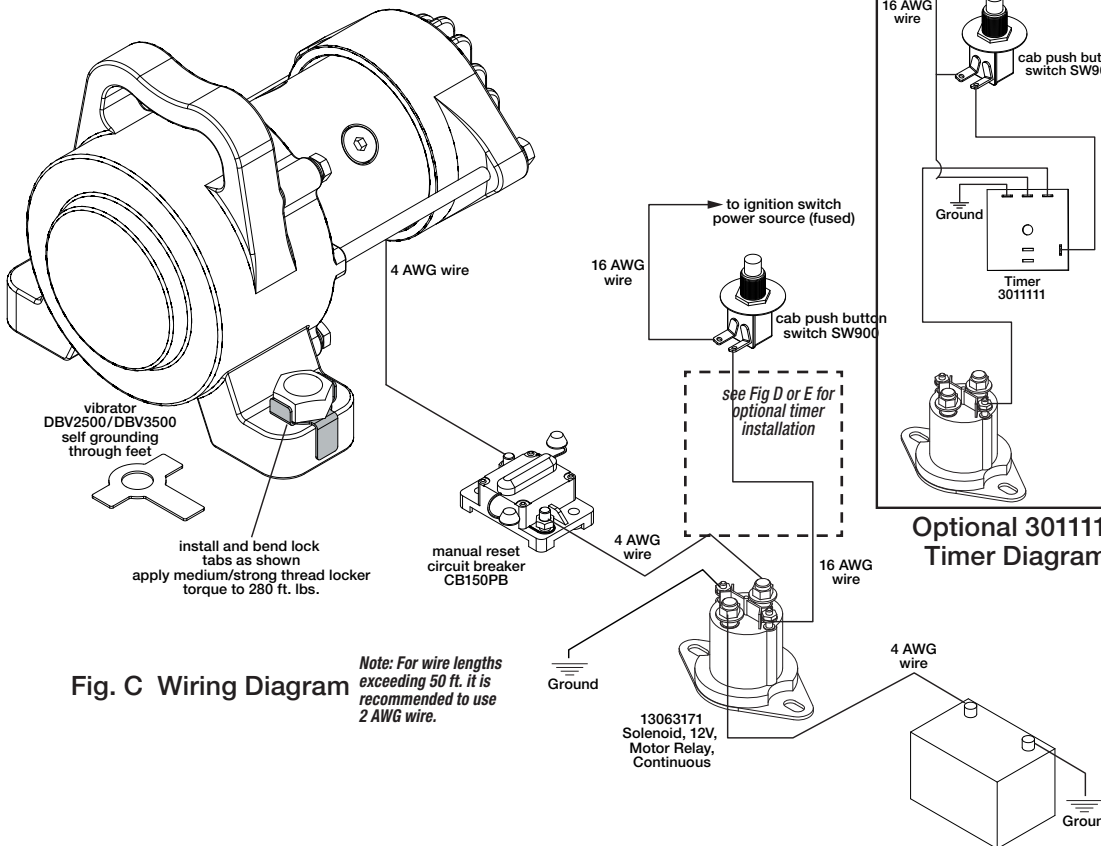
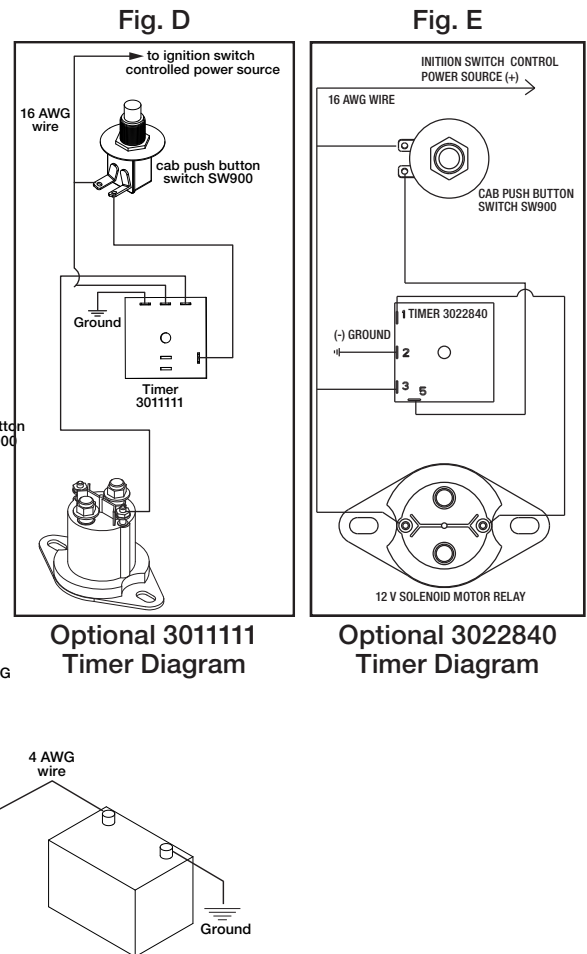

Fig. C Wiring Diagram

Note: For wire lengths exceeding 50 ft. it is recommended to use 2 AWG wire.



Optional 301111 Timer Diagram

Optional 3022840 Timer Diagram

## Vibrator Parts List

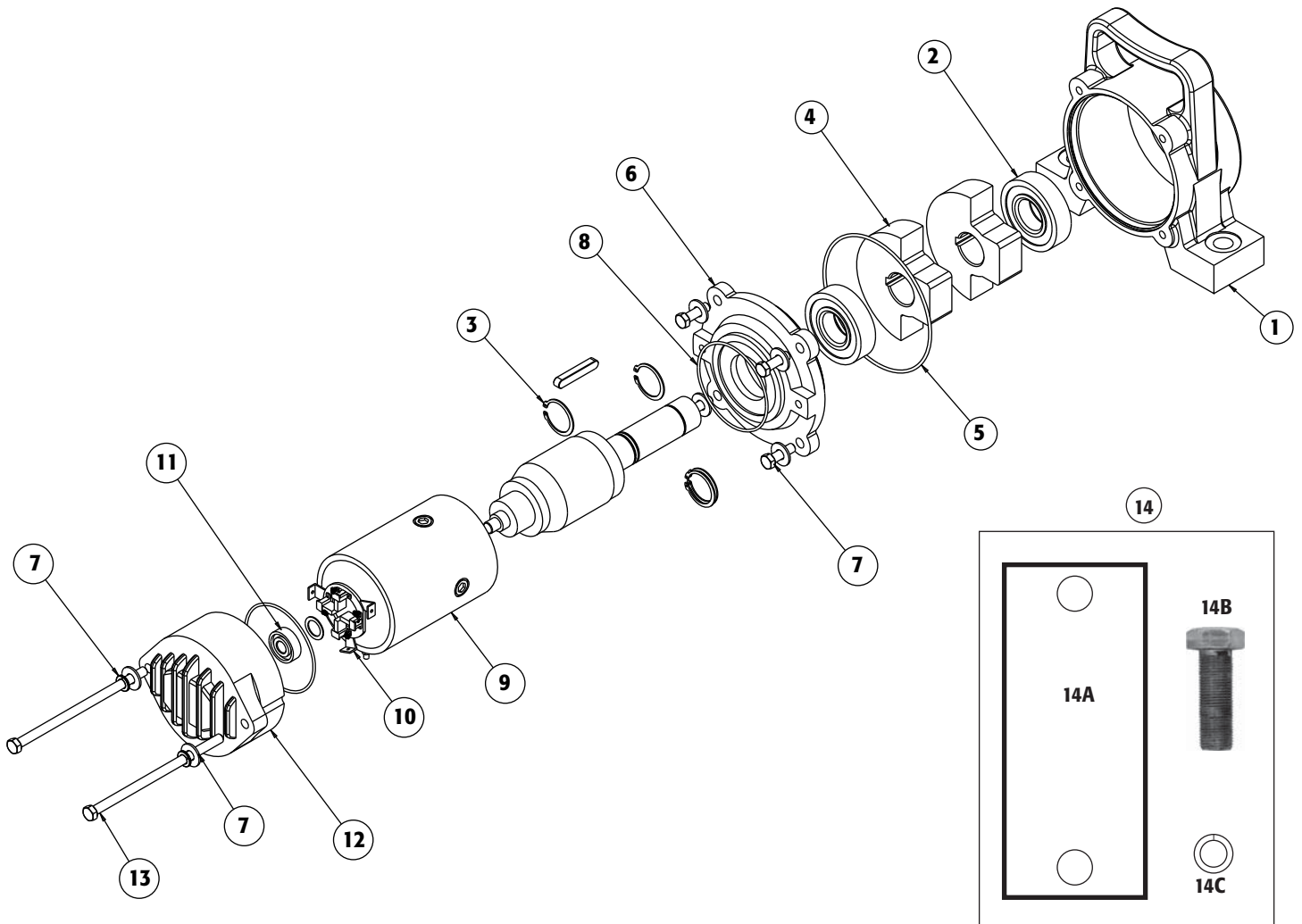

### Bill of Materials

ITEM	PART NO.	QTY.	DESCRIPTION
1	3011078	1	Vibrator Housing
2	3011080	2	Eccentric Shaft Bearings
3	3011081	2	Snap Rings
4	3011082	2	Eccentric Weights
5	3011083	1	Housing Cover "O" Ring
6	3011084	1	Housing Cover
7	3011086	4 Sets	Vibrator Housing Cover Fasteners M10-1.5 x 35 mm
8	3011087	1	Motor "O" Ring
9	3011089	1	12 Volt Motor
10	3011090	1	Brush Assembly Replacement
11	3011091	1 Each	Motor Bearing w/Spring Washer
12	3011092	1	Motor End Cover
13	3011093	2	Tie Rod Fasteners M10-1.5 x 180 mm
14	3009255	1	Mounting Kit, Steel
14A	3011239	1	Mounting Bracket, Steel
14B	3011079	2	Screw Hex Cap .75-16 x 3.5 Grade 8 Zinc
14C	3011238	2	Washer, 1/4" Split Lock Zinc

## 3010636 Vibrator Installation Mounting Kit

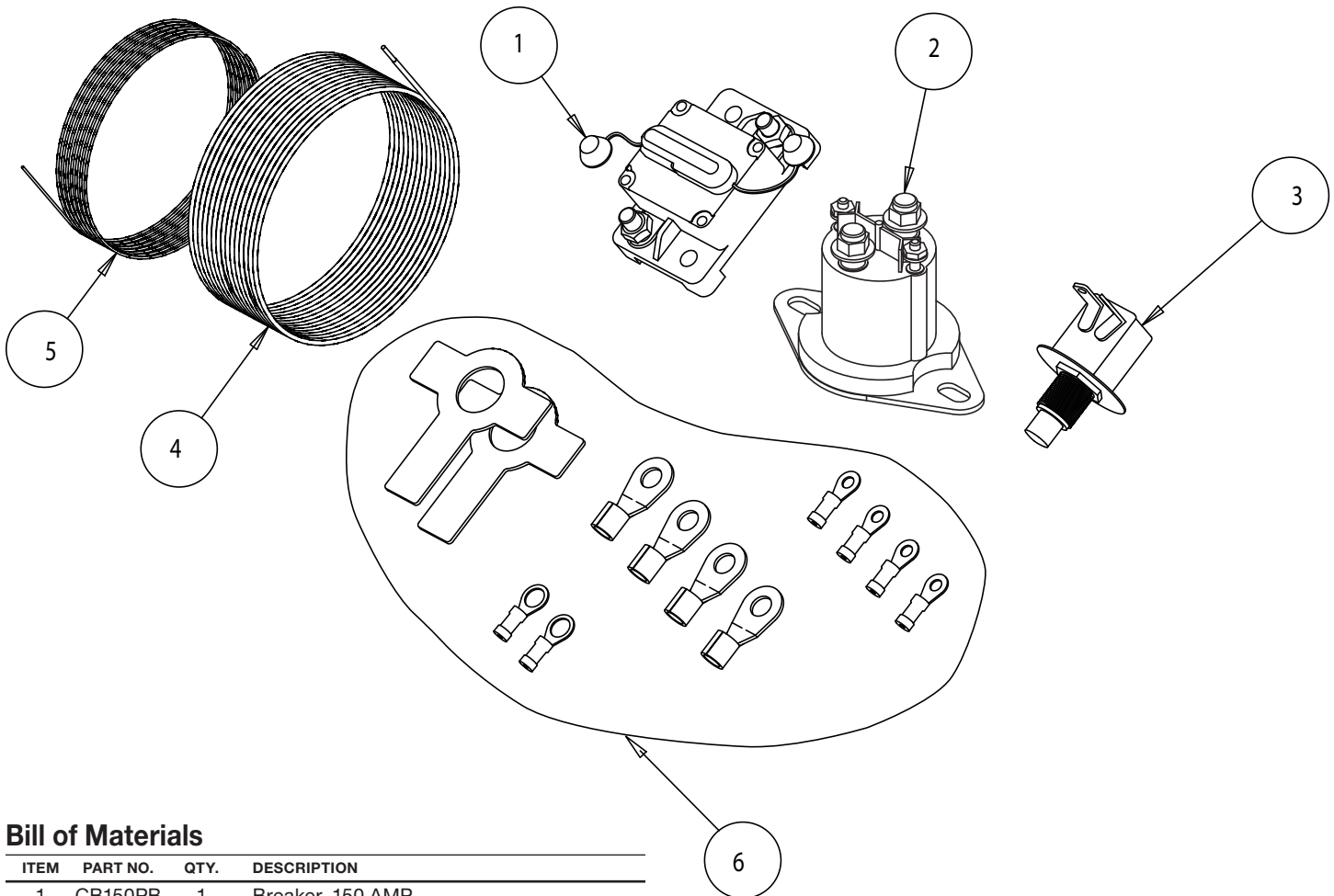

### Bill of Materials

ITEM	PART NO.	QTY.	DESCRIPTION
1	CB150PB	1	Breaker, 150 AMP.
2	13063171	1	Solenoid, 12V, Motor Relay, Continuous
3	SW900	1	Switch, Momentary, 12V
4	3010629	50 ft.	Wire, Copper, 4 AWG, 50'
5	3010631	20 ft.	Wire, 16 Gage, MTW, 20'
6	3010635	1	Hardware, 2500 & 3500 VIB.
-	BTN040	4	Nylon Cable Tie, 4" x .100"
-	3010634	1	Instruction Sheet, Vib Kit

### Warranty

Buyers Products Co. warrants all truck/trailer hardware manufactured or distributed by it, to be free from defects in material and workmanship for a period of one year from date of shipment. Parts must be properly installed and used under normal conditions. Any product which has been altered, including modification, misuse, accident or lack of maintenance will not be considered under warranty. Normal wear is excluded. The sole responsibility of Buyers Products Co. under this warranty is limited to repairing or replacing any part or parts which are returned, prepaid, and are found to be defective by Buyers Products Co. Authorization from Buyers Products Co. must be obtained before returning any part. No charges for transportation or labor performed on Buyers' products will be allowed under this warranty.