

**OWNER'S MANUAL FOR:**  
**44" Rough Cut Mower**  
**w/ Elec. Clutch Blade Engagement**

*This machine is intended for use behind a tractor, ATV or UTV  
to cut field, brush and saplings up to 2" thick.*



## WARNING

**READ and UNDERSTAND this manual completely before using rough cut mower.**

All operators of this equipment must read and completely understand all safety information, operating instructions, maintenance and storage instructions. Failure to properly operate and maintain the mower could result in serious injury or death to the operator and bystanders from moving parts that can cut, amputate, flying objects, burns, fire or explosion or carbon monoxide poisoning and be aware of the following hazards.

- **WARNING:** Keep all guards and shields in place to avoid injury.
- **DANGER:** Do not operate the rough cut mower near people. Debris can be thrown hundreds of feet. Clear work area of foreign objects and debris. Debris thrown by rough cut mower can cause serious injury or death.
- **CAUTION:** Avoid fires. Keep the machine clean of debris, trash and any other flammable material.
- **WARNING:** Tighten all nuts and bolts before starting. Replace or repair any safety device, bolts, etc if damaged or worn.
- **DANGER:** Stay clear of rotating blades. Keep hands and feet away.
- **DANGER:** Never operate rough cut mower without it mounted securely to the tow vehicle.
- **WARNING:** Wear protective clothing. Wear close-fitting clothing and other protective devices appropriate for the job.
- **DANGER:** Keep riders off machine. Riders can be seriously injured or killed by entanglement or by falling.
- **DANGER:** Exercise caution while working near machine. Failure to heed warnings may lead to serious injury or death.
- **DANGER:** Always maintain a safety distance. Never operate rough cut mower with bystander's present. The rough cut mower creates a serious discharge hazard. Never point the discharge direction at anyone. Be aware of where bystanders are located, especially children. Never assume they will remain where you last saw them. Be sure to know what is in the path of the discharge area.

## STOP!

**ADD OIL TO ENGINE BEFORE USING:** Engine is shipped without oil. **DO NOT** start rough cut mower without first adding oil.

**INSPECT COMPONENTS:** Closely inspect to make sure no components are missing or damaged.

See Initial Unpacking and Set-up for instructions and for whom to contact to report missing or damaged parts.

**Any Questions, Comments, Problems or Parts Orders**

Call BRAVE Product Support 1-800-350-8739

# **SAFETY INTRODUCTION**

Your safety, and the safety of others, is very important. To help you make informed decisions about safety, we have provided operating procedures and other information on labels and in this manual. This information alerts you to potential hazards that could hurt you or others.



**This safety alert symbol is used to indicate safety instructions. Follow these instructions to avoid personal injury and/or property damage. Read and follow all instructions in this manual and the included engine manual.**

You will find important safety information in a variety of forms, including:

**Safety Labels** – on the mower.

**Safety Messages** – preceded by a safety alert symbol  and one of three signal words: **DANGER**, **WARNING**, or **CAUTION**.

These signal words mean:



**DANGER:** Indicates an imminently hazardous situation that, if not avoided, will result in death or serious injury. This signal word is to be limited to the most extreme situations typically for machine components which, for functional purposes, cannot be guarded.



**WARNING:** Indicates a potentially hazardous situation that, if not avoided, could result in death or serious injury, and includes hazards that are exposed when guards are removed. It may also be used to alert against unsafe practices.



**CAUTION:** Indicates a potentially hazardous situation that, if not avoided, may result in minor or moderate injury. It may also be used to alert against unsafe practices.

**This entire manual is filled with important safety information. Please read it carefully.**

## **IMPORTANT SAFETY INFORMATION**



**WARNING:** Do not allow anyone to operate this equipment who has not fully read and comprehended the safety manual and who has not been properly trained in the safe operation of the equipment.



**WARNING:** Operator should be familiar with all functions of the unit.



**DANGER:** Keep hands, feet, hair and clothing away from moving parts.



**WARNING:** Remove all objects from the work area that might be picked up and thrown by the blades.



**WARNING:** Do not mow when children and others are around.



**WARNING:** Keep all safety shields and deflectors in place during operation.



**WARNING:** Shut off the engine and allow the mower blades to come to a complete stop before making any adjustments to the mower.



**WARNING:** Shut off engine before disconnecting the mower from the tow vehicle or attempting to move the mower by hand.



**WARNING:** Never carry children or passengers.



**WARNING:** Do not allow children to operate this machine.



**WARNING:** Follow all safety precautions outlined by the manufacturer of the tow vehicle being used to pull this product.

**This entire manual is filled with important safety information. Please read it carefully.**

# WARNING AND BRAND DECALS

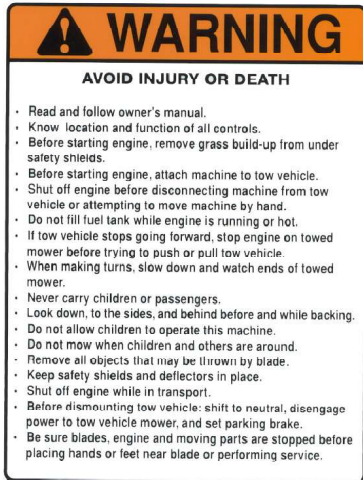

275002 - Warning Decal, General



275003 - Danger Decal, Hand & Foot



275007- Warning Decal, Belt Shield

## ZUBRPRC108H - Decal Sheet Set



**Clean or Replace Any Safety Signs That Are Not Readable or Damaged**  
 Replacement decals can be purchased from your local dealer or  
 Call BRAVE Product Support 1-800-350-8739

# ASSEMBLY INSTRUCTIONS

Read the complete assembly instructions before starting the assembly.

**You should have:**

- one mower deck assembly
- two carrier arm assemblies
- two rear tire assemblies
- one front cross brace tube and one rear cross brace tube with height adjust assy.
- one ATV tongue assembly

**A. ASSEMBLY OF REAR WHEELS AND CARRIER ARMS**

1. Set the mower deck assembly on wood blocks so that it is suspended off the ground.

**Note:** The operator controls are on the front of the deck. (Left and right are determined by looking in the direction of travel or by standing at the rear of the deck assembly looking forward.)

2. Install the rear tire assemblies on the carrier arm assemblies. Remove the hex nut and lock washer from the rear tire assembly and install the 5/8"x7-1/2" tire axle bolt through the hole in the carrier arm assembly. **See figure 1.** Secure assembly with the lock washer and hex nut provided on the rear tire assembly. The rear tires should be offset to the outside of the deck assembly on both sides. **See figure 2.**

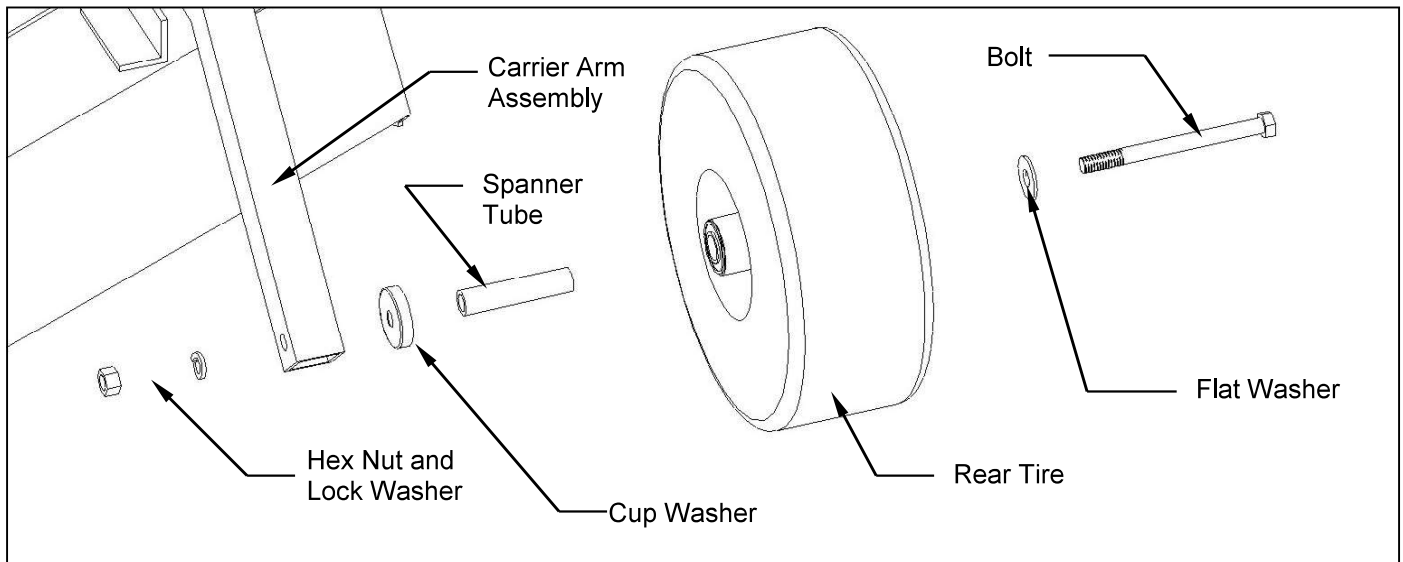

Figure 1: Rear Tire Assembly Installation

3. Install the two carrier arm assemblies in the pivot arms, which are located on the mower deck assembly. Place the assembly so that the castered tires are on the front and the fixed tires are on the back. **See figure 2.** Secure with 1/2" x 3-1/2" hex head bolts and lock nuts provided on the pivot arms.

**Note:** Tighten 1/2" x 3-1/2" hex head bolts until just snug. This area needs to pivot when adjusting the height. Under tightening can result in excessive wear and flexing. Over tightening will make adjusting the cutting height very difficult.

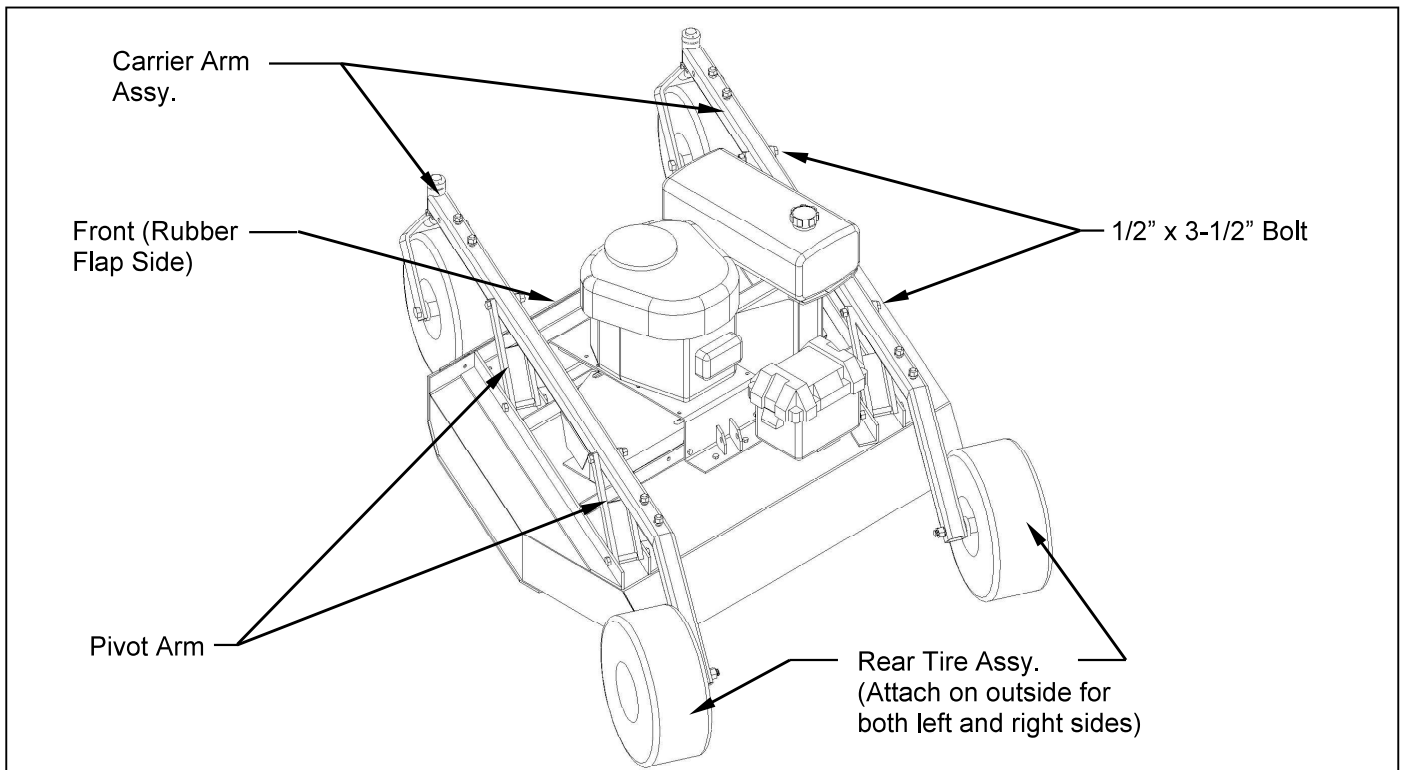

Figure 2: Carrier Arm Installation

## B. INSTALLATION OF CROSS BRACE TUBES AND HEIGHT ADJUST ASSY.

For this section, if your mower was purchased with an Electric Lift Kit (Part #003912), refer to Section C of the Electric Lift Kit Owner's Manual.

1. Remove the 1/2" x 3" hex head bolts, lock washers and nuts that are located on the top of each carrier arm (four per carrier arm). The removed hardware will be used in step 2.
2. Install the cross brace tubes on the carrier arms with the 1/2" x 3" hex head bolts, lock washers and nuts. Only hand tighten the hardware for this step. The support that has the height adjust assy. fastened to it needs to be placed on the rear location. Orientate the support such that the height adjust assy. hangs towards the engine. **See figure 3.**
3. Remove the 1/2" x 1" bolt and lock nut from the lower deck mount. Manually turn the screw down towards the deck until the screw mounting flat hole lines up with the lower deck mount hole. After achieving alignment, attach the screw mounting flat with the 1/2" x 1" hex head bolt and secure the bolt with the provided lock nut. Do not over-tighten. This location must be able to pivot. **See figure 4.**

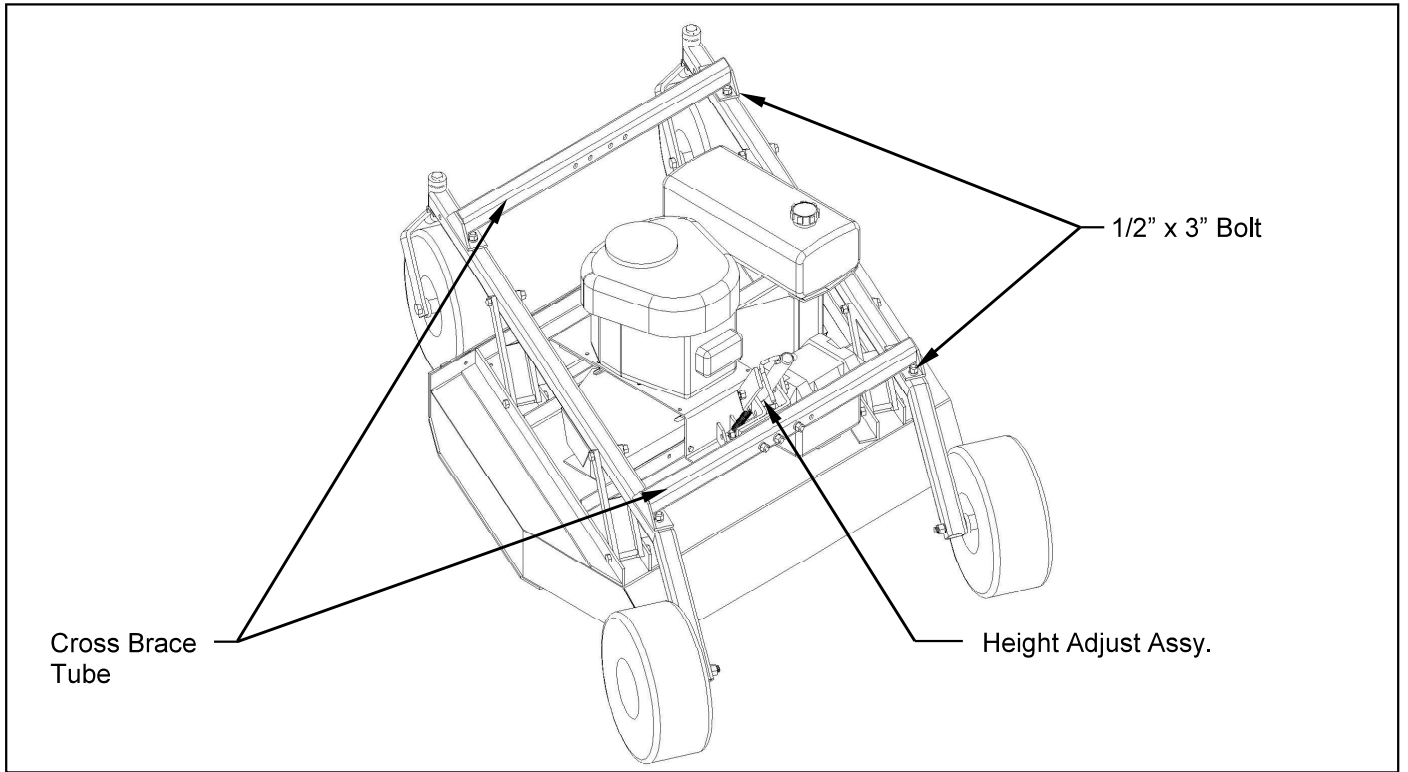

Figure 3: Cross Brace Tube Installation

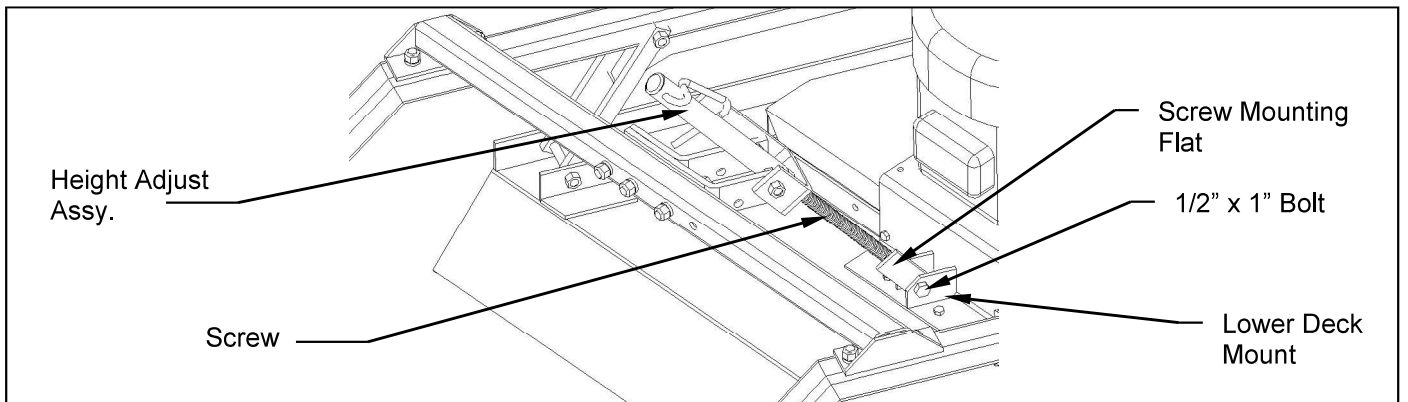

Figure 4: Height Adjust Assy. Installation

4. Turn the crank on the height adjust assy. and raise the mower to its highest position. At this time securely tighten the 1/2" x 3" hex head bolts, lock washers and nuts holding the cross brace tubes in place. This step insures that proper alignment of the carrier arms has been achieved.

### C. INSTALLATION OF TONGUE ASSEMBLY

1. The tongue can be installed either on the left or right carrier arm assembly depending on how the tow-behind mower will be towed. **See figure 5.** Secure the hitch pivot on the chosen carrier arm assembly with the 1/2" x 3-1/2" hex head bolt, lock washer, and nut provided.
2. Install the tongue into the hitch pivot and secure by placing the provided 5/16" wire lock pins on each side of the hitch pivot.

**Note:** To help prevent any unwanted pin removal caused by oncoming debris install the 5/16" wire lock pins with the wire lock section back from the direction of travel. **See Figure 6.**

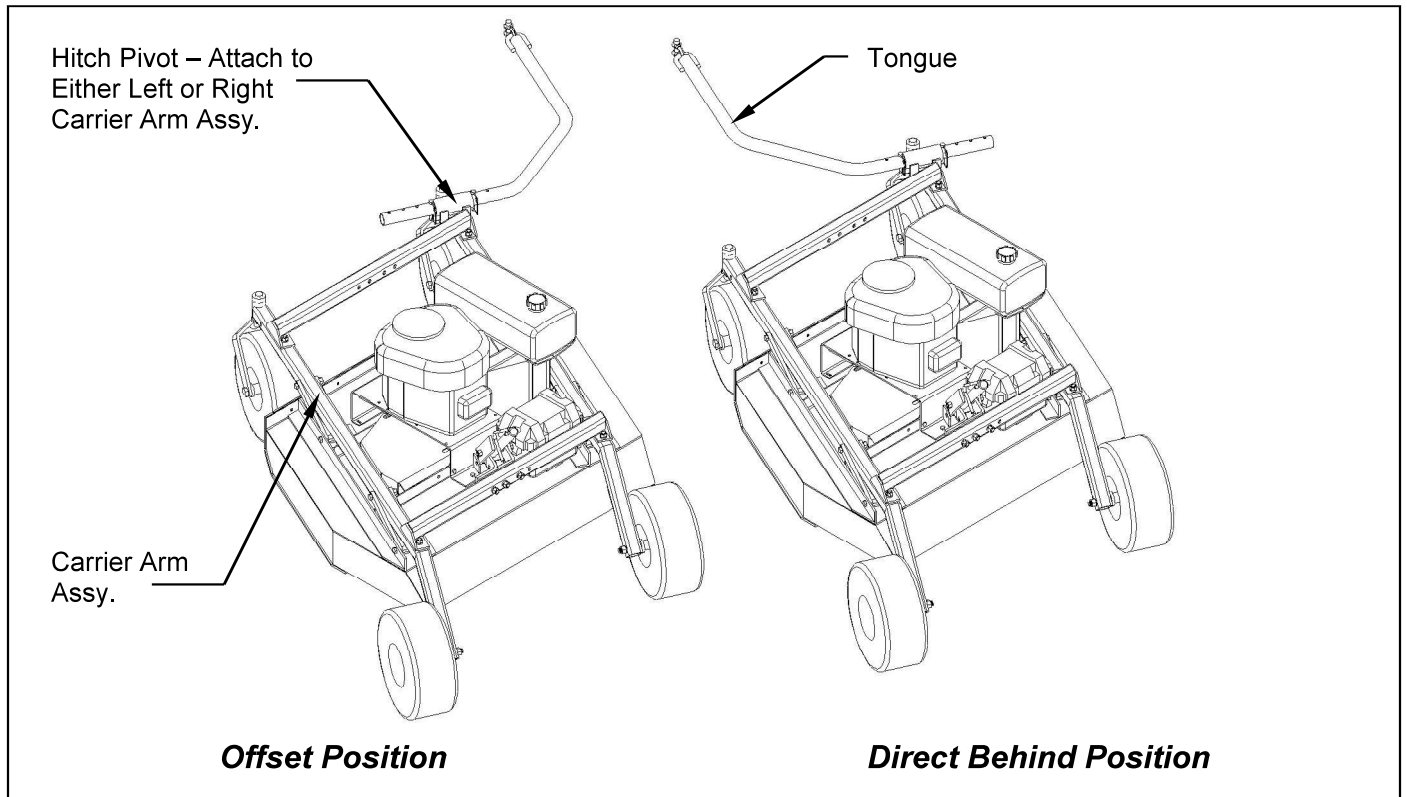

Figure 5: Assembly of the Tongue and Hitch Pivot

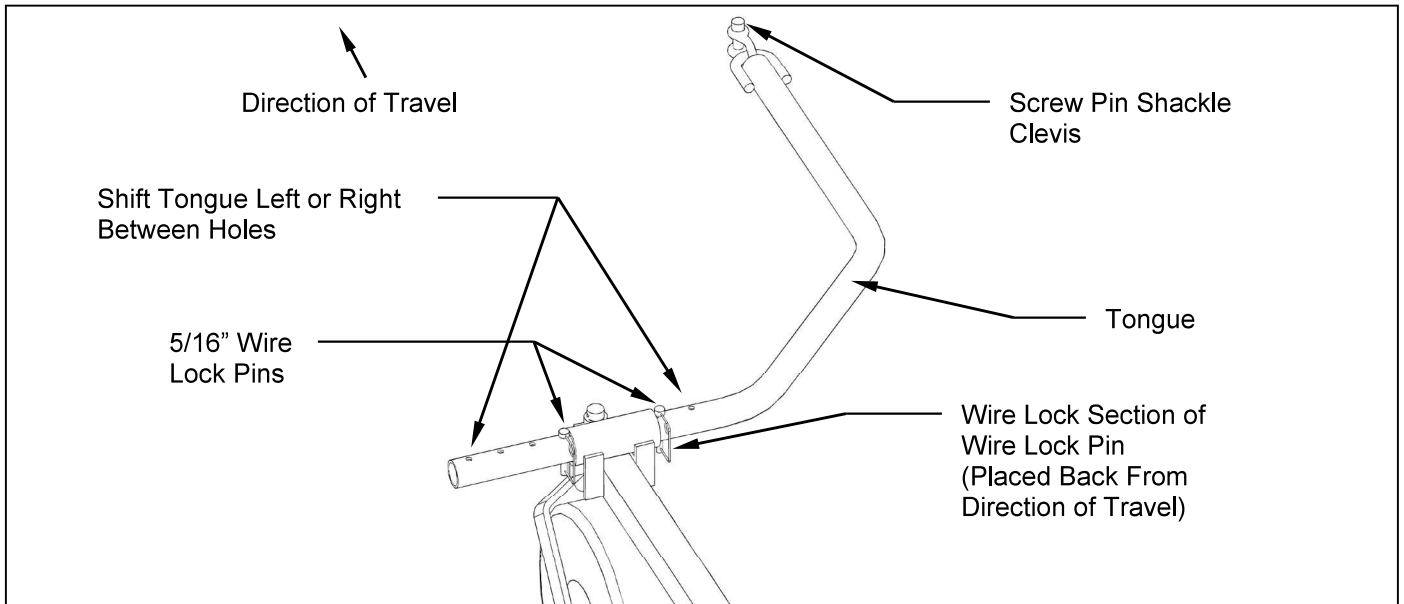

Figure 6: ATV Tongue Assembly

## OPERATIONS AND ADJUSTMENTS



This safety alert symbol is used to indicate safety instructions. Follow these instructions to avoid personal injury and/or property damage. Read and follow all instructions in this manual and the attached engine manual.



**WARNING:** Do not allow anyone to operate this equipment who has not fully read and comprehended the safety manual and who has not been properly trained in the safe operation of the equipment.



**WARNING:** Operator should be familiar with all functions of the unit.

### A. TONGUE CONFIGURATIONS AND ADJUSTMENTS



**WARNING:** Shut off the engine and allow the mower blades to come to a complete stop before adjusting the tongue.

The hitching system is designed so that the rough cut mower can be pulled directly behind a tow vehicle or offset to the left or right. **See Figure 7.**

**Note:** When pulling the mower directly behind, the hitch pivot should be fastened on the right carrier arm for maximum maneuverability. **See Figure 5.** When pulling the mower in the offset position the hitch pivot can be fastened on either the right or left carrier arm. **See Figure 5.**

The tongue is equipped with a screw pin shackle clevis to provide movement in all directions on rough uneven ground. To prevent loss of the screw pin due to vibration or debris, place the screw pin through the tow vehicle hitch and clevis and turn the screw pin until snug.

The tongue is designed to adjust from left to right within the hitch pivot. This allows the mowers position to be varied behind the tow vehicle. This is accomplished by pulling the 5/16" wire lock pins out and choosing two other hole locations on the tongue. **See Figure 6.**

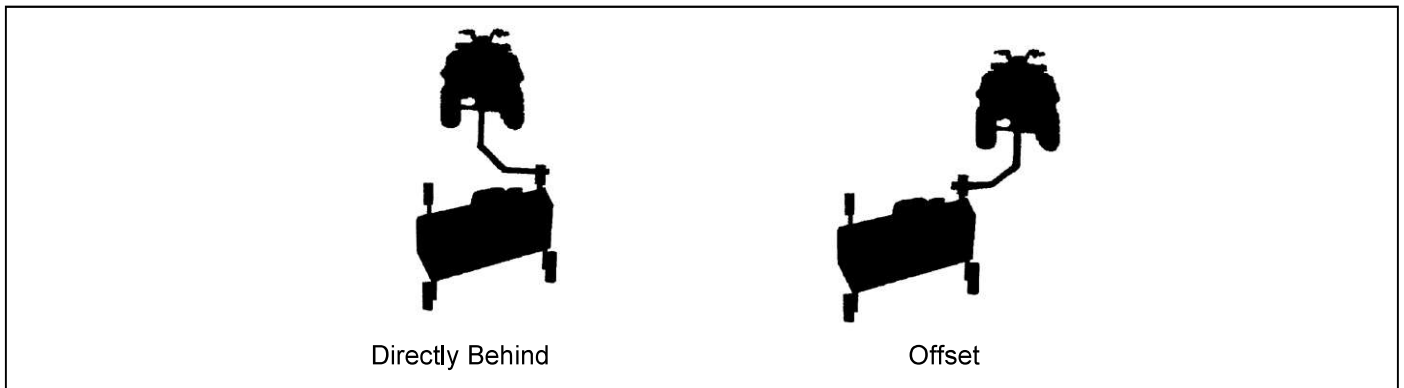

Figure 7: Rough Cut Tow Behind Towing Suggestions

### B. ADJUSTING CUTTING HEIGHT



**WARNING:** Shut off the engine and allow the mower blades to come to a complete stop before adjusting the cutting height.

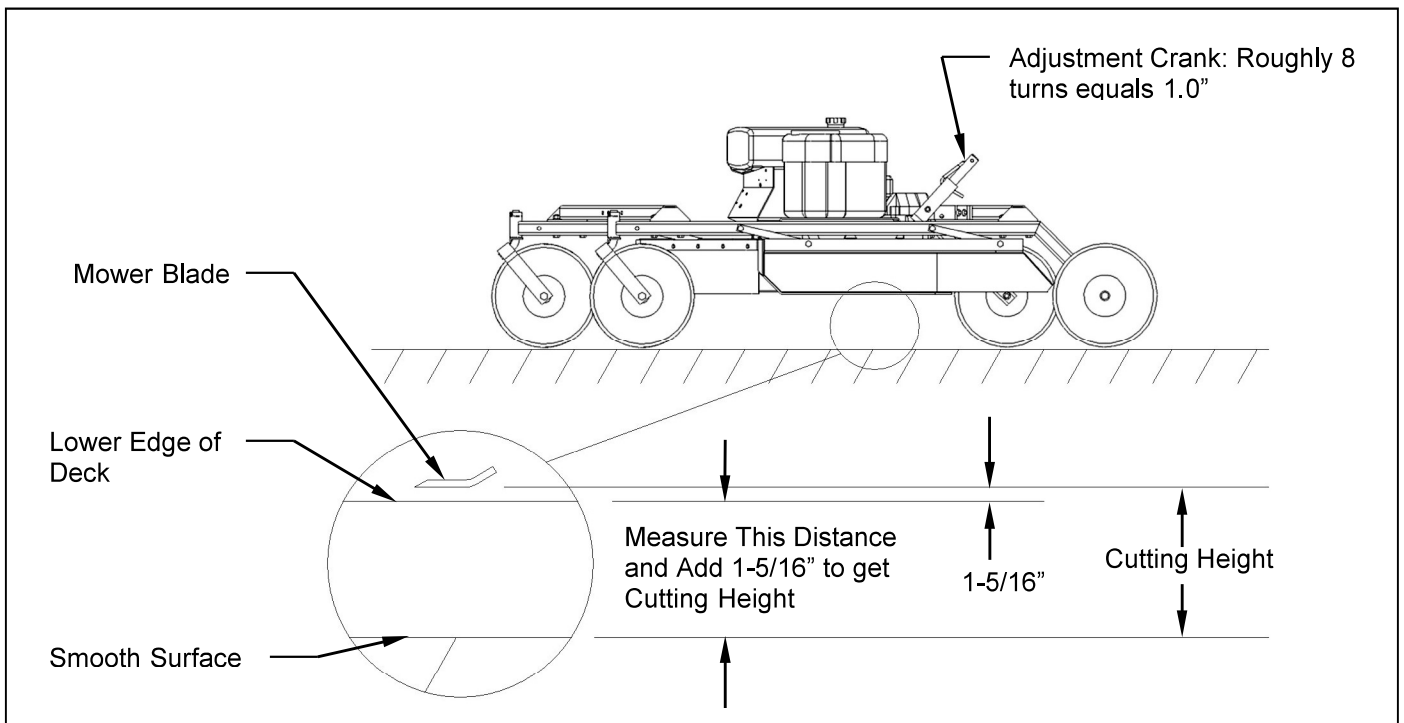

Figure 8: Adjusting Rough Cut Mower Cutting Height

The cutting height can be adjusted in a range from 2.0" to 8.0". This is accomplished by turning the height adjust crank located at the back of the mower. **See Figure 8.** Turn the crank clockwise to raise the mower cutting height and counter-clockwise to lower the mower cutting height.

**⚠ DANGER:** Shut off tow vehicle engine and allow mower blades to stop completely before attempting to measure the cutting height.

Adjust the mower as follows:

1. Pull the mower on to a smooth, level surface.
2. The desired cutting height can be determined by measuring the distance from the ground to the outside lower edge of the mower deck and adding 1-5/16". The mower blade cutting edge is 1-5/16" above the outside lower edge of the mower deck.

**Note:** If the height adjust crank does not turn easily, the pivot bolts holding the carrier arm assemblies and height adjust screw may be too tight. Loosen the pivot bolts slightly to allow easier pivoting. Care should be taken not to loosen too much or excess wear and flexing may occur. Greasing the threads on the height adjust screw may also allow greater ease in adjustment.

**Note:** After setting the initial cutting height, quick field adjustments can be completed by counting crank turns. Roughly 8 turns will equal 1" of vertical movement.

The adjustment crank may turn due to vibration. This will allow the mower's cutting height to change. The crank can be secured by folding it down between the adjustment nut tube and the height adjust support. **See Figure 9.**

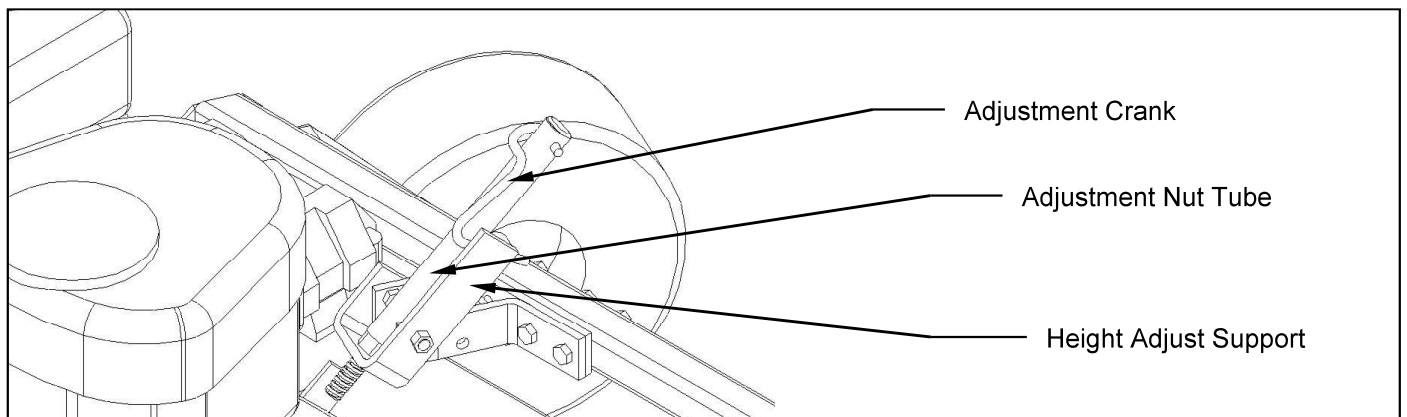

Figure 9: Securing Crank While Not In Use

### C. STARTING ENGINE



**WARNING:** Set parking brake on tow vehicle.

Attach mower tongue to tow vehicle.



**WARNING:** Do not start rough cut mower unless it is attached to the tow vehicle.

Turn on the fuel shut off valve (red colored rotating knob) located inline on the fuel hose. The **off** position on the valve is when the red handle lines up with the “O” symbol.

Set the choke to the desired position.

Set the throttle at approximately half throttle.

Start engine and allow engine to warm up.

Set engine speed at about half throttle and engage the mower blades clutch by pulling outward on the PTO switch. (The PTO switch is located at the front of the mower deck on the control panel.)

**Note:** To help extend the life of the clutch the engine rpm should be placed as low as possible before clutch engagement. If the engine should stall during clutch engagement raise the engine rpm until clutch engagement is possible.



**CAUTION:** If the mower’s engine dies while in use, remove the rough cut mower from the uncut area before attempting to engage the clutch. Inspect the blades for any obstructions that may prevent blade engagement. Failure to follow these instructions may result in premature belt failure or a fire.

Adjust engine speed to full throttle.

### D. SHUTTING OFF ROUGH CUT MOWER



**WARNING:** Shift to neutral and set the parking brake before dismounting the tow vehicle.

Slow the engine speed down and disengage the clutch by pushing inward on the PTO switch.

Allow engine to cool down for a short time before moving the ignition switch to the **off** position.

Turn off the fuel shut off valve (red colored rotating knob) located inline on the fuel hose. The **off** position on the valve is when the red handle lines up with the “O” symbol.

## E. MOWER OPERATION



**DANGER:** Keep hands, feet, hair and clothing away from moving parts.



**CAUTION:** Clean or replace any safety signs that are not readable or damaged.



**WARNING:** Remove all objects from the work area that might be picked up and thrown by the blades.



**WARNING:** Do not mow when children and others are around.



**WARNING:** Do not fill fuel tank while engine is running or hot.



**WARNING:** Keep all safety shields and deflectors in place during operation.



**CAUTION:** Remove grass build up from under safety shields before each use. Do not remove safety shields while engine is running. Dry grass build up around belts and sheaves can cause fires.



**WARNING:** Shut off engine before disconnecting the mower from the tow vehicle or attempting to move the wing mower by hand.



**WARNING:** Never carry children or passengers.



**WARNING:** Do not allow children to operate this machine.



**CAUTION:** Slow down and watch the ends of the mower when making turns so objects are not struck and/or run over.



**WARNING:** Look down, to the sides, and behind before and while backing to avoid backing over something or someone. Care should also be taken while backing so that the wing mower or mowers do not jackknife and damage hitches.



**WARNING:** Stop the mower blades on the mower if the tow vehicle becomes stuck or stops going forward because of loss of traction. Shut off the engine on the mower before attempting to push or pull the tow vehicle.

Listen to the rough cut mower engine while mowing. The engine should run free and not work too hard. Working the engine too hard will cause overheating and premature failure.



**CAUTION:** If the mower's engine dies while in use, remove the rough cut mower from the uncut area before attempting to engage the clutch. Inspect the blades for any obstructions that may prevent blade engagement. Failure to follow these instructions may result in premature belt failure or a fire.

Do not allow material to build up on the air inlet to the engine cooling system. Special care should be taken to make sure the engine is getting enough inlet air. Do not allow the engine cooling fins under the shroud to be blocked. If air flow over the engine is restricted, the engine could overheat.

## F. DRIVE BELT REMOVAL AND TENSION – Refer to Figure 10



**WARNING:** Shut off engine and allow mower blades to stop turning before making any adjustments or repairs.

Remove the safety shields.

Loosen the nuts on the spring-loaded idler; adjust bolt until the belt can be slipped off the idler and drive sheaves.

Slip the belt down under the drive sheave and off the blade spindle sheaves.

Install the new belt and then adjust the tension as follows: **See Figure 10.**

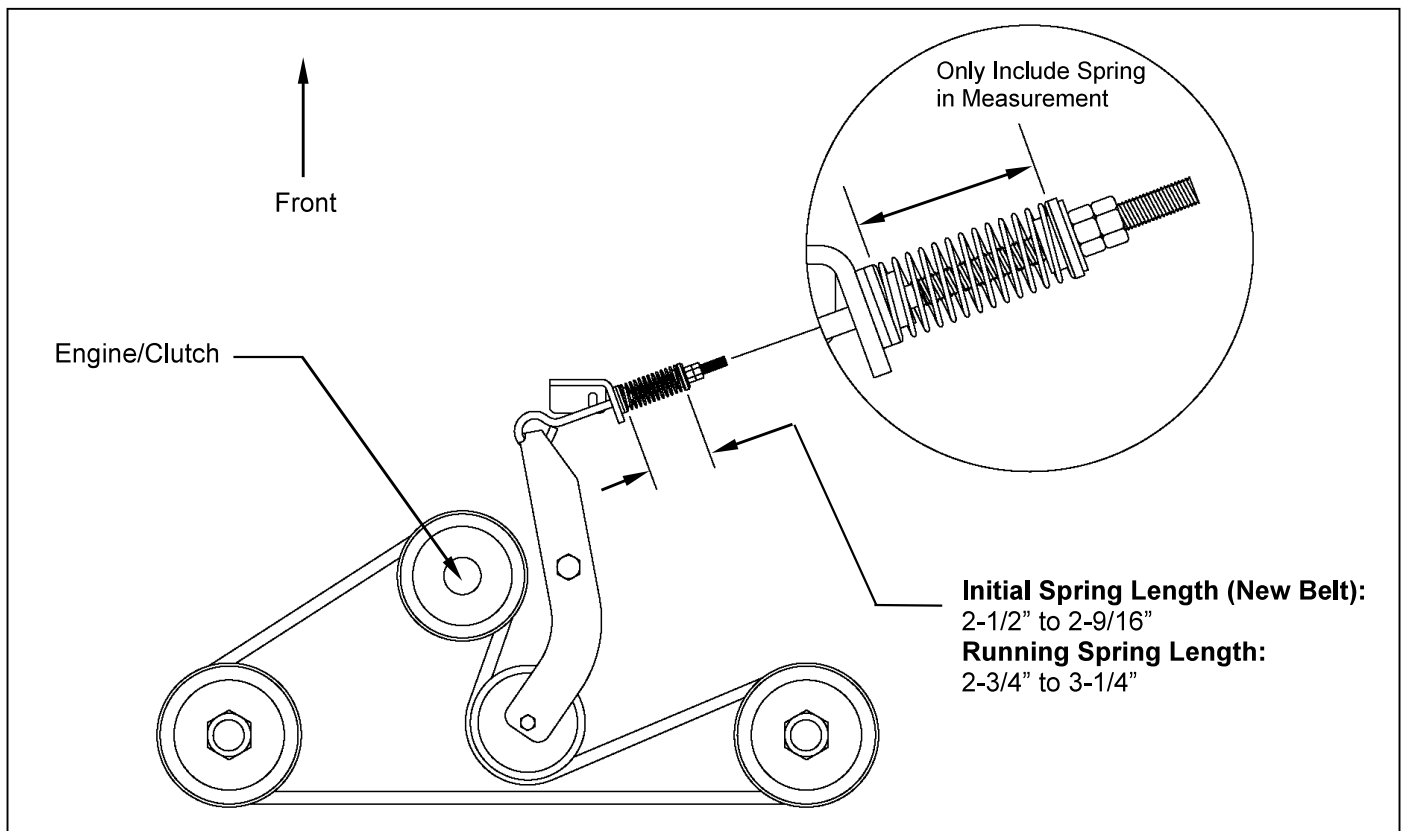

Figure 10: Belt Pattern, Spring Adjustment, and Brake Adjustment

Adjust the nuts on the spring-loaded idler adjuster bolt until the length of the spring is between 2-1/2" and 2-9/16". This is the initial belt break in spring length. When the belt is broken in after several hours of mowing, the running spring length should be between 2-3/4" and 3-1/4". For maximum belt life, periodic checks every 3-4 hours should be done to make sure the spring length has not exceeded the recommended running length.

**Note:** Failure to periodically adjust the belt tension will result in severe belt wear and premature belt failure.

## G. MOWER BLADE REMOVAL, BALANCING & INSTALLATION



**CAUTION:** Sharp blades can cause bodily injury if not handled properly.

When removing the blade, it is recommended that a block of wood be placed between the blade and the underside of the mower deck. This will allow the removal of the blade without the need to hold the blade by hand.



**CAUTION:** Always balance the mower blades each time they are sharpened.

Out of balance mower blades cause excessive vibrations which lead to premature bearing failures, bolts coming loose, and overall deterioration of the mower.



**CAUTION:** Always properly tighten the blade bolts to the specified torque. Failure to do so can lead to unwanted loosening of the blade and damage to the blade holding saddle.

The Model BRPRC108HE uses Part # (202141) blade bolt. This particular hex head bolt is a 3/4" – 16NF x 1-1/4" long, grade 5 and its proper torque is 300 ft-lbs.

To ease in the blade installation process, use the same block of wood and method used during the removal of the blades.

## H. LUBRICATION

There are three lubrication points on the rough cut mower -- one spring-loaded idler pivot and two caster wheel pivots. Lubricate at approximately 10 hr. intervals or more often as required in dusty conditions.

## I. FUSE LOCATION

These particular mowers come equipped with a 10 AMP mini blade type fuse. The fuse is located behind the ignition switch/control panel in a black rubber inline fuse holder.

## J. STORAGE

Turn off the fuel shut off valve (red colored rotating knob) located inline on the fuel hose. The **off** position on the valve is when the red handle lines up with the "O" symbol. If the mower is stored outside, the engine should be covered to prevent water from getting inside the engine during heavy rainstorms. See the Engine Manual for additional information.

## **K. EPA EVAPORATIVE COMPONENTS**

This mower has been designed and built to meet all current EPA regulations. Any modification to the fuel tank, fuel lines, vapor hose, fuel cap, roll-over / fuel vapor valve, carbon canister (California Only) and hose clamps are prohibited. Replacement evaporative components should be purchased from Brave. Any questions about EPA regulations or evaporative components can be directed to Brave at 800-350-8739

# **BRPRC108HE ROUGH CUT MOWER SPECIFICATIONS**

Model	BRPRC108HE
<b><u>ENGINE</u></b>	
Engine Make	Honda
Engine Model	GXV630RHQYF
Engine Muffler	MUF-0526-KIT
Cylinders	2
Cycles	4
Crankshaft	Vertical
Engine HP	20.8 @ 3600
Bore	78mm 3.07in
Stroke	75mm 2.83in
Displacement	688cm, 41.97 cu-in
Oil Capacity	1.7 Liters, 1.8 quart
Crankshaft Dia.	1 inch
Key Slot	.25 in
Crankshaft Length	3.11 inch
Threaded Hole in End of Crankshaft	7/16-20UNF2B
Engine Mounting Bolts	5/16-18x1.50 Through Bolt
Starter	12 volt
Choke	remote cable
<b><u>MOWER</u></b>	
Fuel Tank	3 Gallon
Effective Cutting Width	44"
Deck Construction	8 ga. Welded steel
Cutting Height	2" to 8"
Height Adjustment	Single Crank
Rear Wheels (Fixed) (4 ply Turf Pneumatic)	Two 15/600 x 6
Front Wheels (Caster) (4 ply Turf Pneumatic)	Two 5.30/4.50 x 6
Blade Dia.	2-23"
Engine Speed, Blades Running	3500 RPM
<b><u>CLUTCH</u></b>	
Type	Electric Clutch
<b><u>DIMENSIONS</u></b>	
Length	95.5"
Width	46.5"
Height	29"
Weight	530 lbs.
<b><u>HITCH</u></b>	
Hitch Type	ATV Tongue

# **BRPRC108HE ROUGH CUT MOWER PARTS LIST**

<b>Item</b>	<b>Part #</b>	<b>Description</b>	<b>Quantity</b>
1	202141	Blade Bolt, .75"-16UNF x 1.25"	2
2	214030	Cup Washer	6
3	216002	Wire Lock Pin, .31" x 2.50"	2
4	216009	Screw Pin Shackle Clevis	1
5	222005	Worm Drive Hose Clamp (7-7/8" to 9-1/8" Clamping Dia.)	2
6	222012	Single Split Collar (1" I.D. x 1/2: Thick)	2
7	225005	Compression Spring, 4-1/2"L x 1-3/32" O.D. x .125" Wire dia.	1
8	226012	Offset Wheel Assy. (15/600 x 6, 4 Ply Turf)	2
8	226014	Offset Wheel Assy. (15/600 x 6, Urethane Foam-Flatproof)	Optional
9	226013	Centered Wheel Assy. (5.30/4.50 x 6, 4 Ply Stud)	2
9	226015	Centered Wheel Assy. (5.30/4.50 x 6, Urethane Foam-Flatproof)	Optional
10	238007	"V" Belt, .62" x 77" O.C. (B74K)	1
11	241001	Flat Idler, 4" O.D. x 3/8" Hole	1
12	243010	Plastic Bearing (1-3/8" O.D. x 1.00" I.D., Flange, Nylon)	4
13	243015	Precision Sealed Wheel Bearings (2" O.D. x 1" I.D.)	8
14	258018	Electric Clutch	1
15	258023	Spindle Assy.	2
	900075	Spindle Shaft (1)	
	900160	Housing Assy. (With Two Bearings) (1)	
	243006	Bearing (6206 w/ Trash Guard Seals) (2)	
	600271	Bearing Spacer (3.33" Long) (1)	
	241011	Sheave, (5.56" Dia., B-Section) (1)	
16	259008	Offset Mower Blade, 2-1/2" Wide, 23" Long, 3/4" Hole	2
17	260004	Roll-Over / Fuel Vapor Valve (Includes Gromet)	1
18	264000	Solenoid	1
19	264010	Ignition Switch	1
20	264003	Hour/Tack Meter	Optional
21	269000	Choke Control, 20"	1
22	269009	Throttle Control, 27"	1
23	275001	Control Panel Decal, Starting Instructions	1
23	275002	Warning Decal General	1
23	275003	Danger Decal, Cut Finger	2
23	275007	Warning Decal, Belt Sheild	2
23	275011	Clutch Engagement Decal	1
23	ZUBRPRC108H	Branding Decal & Safety Decal Sheet Set	1
24	277002	Rubber Gromet	6
25	277035	Gas Cap - Audible Click/Tethered, Non-Venting	1
26	277036	Carbon Canister - 300cc (California Only)	1
27	277040	Fuel Tank, 3 Gal., 3-Layer EPA Certified	1
28	600146	Crank Arm	2
29	600185	Top Long Support	1
30	600186	Top Short Support	1
31	600198	Clutch Stop	1
32	600252	Flap Retainer Strip	1

<u>Item</u>	<u>Part #</u>	<u>Description</u>	<u>Quantity</u>
33	600253	Safety Belting	1
34	600254	Battery Box Spacer	2
35	600264	Belt Sheild, Left	1
36	600265	Belt Sheild, Right	1
37	600268	Height Adjust Support	1
38	600291	Canister Support (California Only)	1
39	600305	Control Panel	1
40	600306	Tank Support	1
41	600314	Spring Support Bracket	1
42	600315	Tube Spacer (1.32" O.D. x .88" Long)	1
43	900049	Battery Box Assy.	1
44	900058	Hitch Pivot	1
45	900061	Pivot Arm	4
46	900082	Tongue	1
47	900148	Caster Fork	1
48	900150	Engine Support Bracket	1
49	900154	Upper Actuator Mount	2
50	900155	Carrier Arm	2
51	900156	Mower Deck	1
52	900157	Height Adjust Nut	1
53	900158	Screw Adjuster	1
54	900192	Idler Arm Assy.	1
	243016	Bronze Bearing, 5/8" I.D. x 3/4" O.D. x 3/4" Long	2

# BRPRC108HE 44" ROUGH CUT MOWER

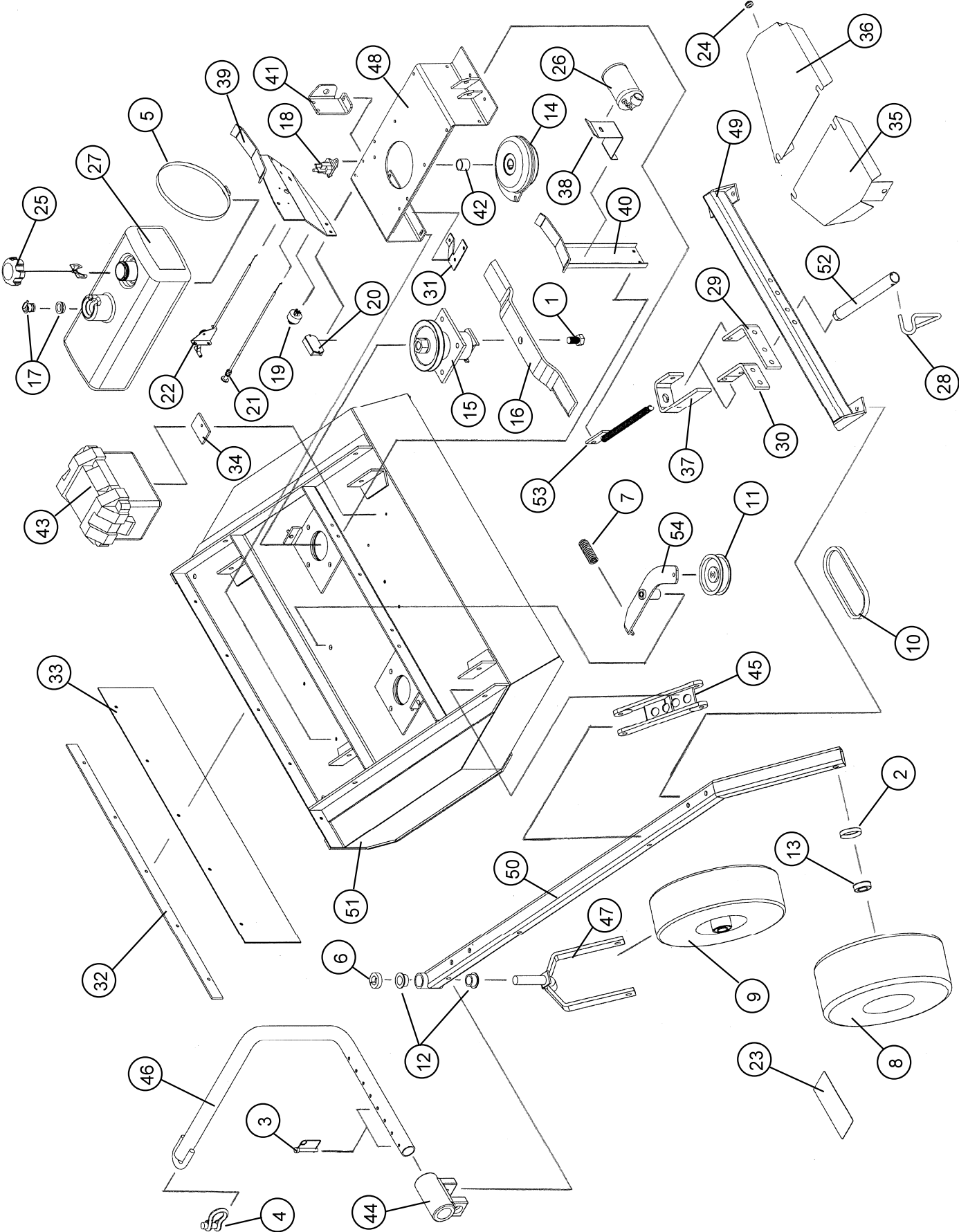



20195 South Diamond Lake Road, Suite 100 • Rogers, MN 55374  
 Toll-Free: 800-350-8739 • Website: braveproducts.com • Email: sales@braveproducts.com

**Dear Valued Customer:**

The Brave product you just purchased is built with the finest material and craftsmanship. Use this product properly and enjoy the benefits from its high performance. By purchasing a Brave product, you show a desire for quality and durability. Like all mechanical equipment this unit requires a due amount of care. Treat this unit like the high-quality piece of machinery it is. Neglect and improper handling may impair its performance.

Thoroughly read the instructions and understand the operation before using your product. Always contact Brave Product Support at 1-800-350-8739 prior to having any service or warranty work performed, as some services performed by parties other than Brave approved service centers may void this warranty. This limited warranty is in lieu of any other warranty expressed or implied, written or oral and Brave assumes no other responsibility or liability outside that expressed within this limited warranty.

**Limited Warranty for Brave Tow-Behind Mowers:**

**Models:**

**BRPRC108HE**

**BRPRC110HE**

**BRPFC112HE**

	<b>Consumer Warranty Period</b>	<b>Commercial Warranty Period</b>
<b>Weldments</b>	2 years from date of purchase by user	2 year from date of purchase by user
<b>Wear Parts</b>	In addition to the normal warranty, Brave shall warrant some normal wear items from defects in material or workmanship for a period of 30 days from the date of purchase by user. Normal wear items covered under this warranty are limited to: High impact wear related components such as standard retention hardware for wear items, spindles, bearings, belts and bushings, clutch/brake assembly, tires, blades, battery, cables, switches. Routine maintenance items such as lubricants, clutch adjustments, tune ups are not covered under warranty.	
<b>Engines</b>	The engine warranty is covered under the terms and conditions as outlined by the engine manufactures warranty contained herein and is the sole responsibility of the engine manufacturer. Normal engine maintenance such as spark plugs, oil changes, air filters, adjustments, fuel system cleaning and obstruction due to build up is not covered by this Brave limited warranty.	

“**Consumer use**” means personal residential household use by a consumer. “**Commercial use**” means all other uses, including, but not limited to, use for commercial, income producing or rental purposes or when purchased by a business.

This limited warranty applies to the original purchaser of the equipment (verification of purchase, in the form of a receipt, is the responsibility of the buyer), is non-transferable, and covers parts and labor. Parts will be replaced or repaired at no charge, except when the equipment has failed due to lack of proper maintenance. If a part is no longer available, the part may be replaced with a similar part of equal function. Any misuse, abuse, alteration or improper installation or operations will void warranty. Determining whether a part is to be replaced or repaired is the sole decision of Brave. Brave will not provide for replacement of complete products due to defective parts. Any costs incurred due to replacement or repair of items outside of a Brave approved facility is the responsibility of the buyer and not covered under warranty. Transportation costs to and from service center and/or service calls are the responsibility of the customer.

This limited warranty specifically excludes the following: failure of parts due to damage caused by accident, fire, flood, windstorm, acts of God, applications not approved by Brave in writing, corrosion caused by chemicals, use of replacement parts which do not conform to manufacturer’s specifications, damage related to rodent and/or insect infestation and damage caused by vandalism. Additional exclusions: loss of running time, inconvenience, loss of income, or loss of use, including any implied warranty of merchantability of fitness for a specific use. Also, outdoor power equipment needs periodic parts and service to perform well, and this limited warranty does not cover instances when normal use has exhausted the life of a component or the engine.

This limited warranty does not cover any personal injury or damage to surrounding property caused by failure of any part, misuse or inability to use the product. Alteration of the product, including safety features, shall void this limited warranty.

Repair or replacement of parts does not extend the warranty period. This limited warranty gives you specific legal rights. You may also have other rights that vary by state. Please have model number, item number and serial number on hand prior to making a warranty claim or inquiry.

*For products purchased on or after January 1, 2018*

*PAGE INTENTIONALLY LEFT BLANK*



Brave  
Product Registration Form

**YOUR INFORMATION**

Full Name:

\_\_\_\_\_  
Last First M.I.

Address:

\_\_\_\_\_  
Street Address Apartment/Unit #

\_\_\_\_\_  
City State ZIP Code

Home Phone:

\_\_\_\_\_  
Alternate Phone: \_\_\_\_\_

Email

\_\_\_\_\_

**PURCHASED FROM**

Company:

\_\_\_\_\_

Address:

\_\_\_\_\_  
Street Address Apartment/Unit #

\_\_\_\_\_  
City State ZIP Code

**MODEL INFORMATION**

Purchase Date

\_\_\_\_\_

Application Type

Homeowner  Commercial  Rental

Model (i.e. BRPT704H)

Serial # (i.e. 123456)

Signature

\_\_\_\_\_

***Register your product online at [www.braveproducts.com](http://www.braveproducts.com)***

# BRAVE

---

A GNE BRAND

**BRAVE**

*A Brand of:*

*Great Northern Equipment Distributing, Inc.*

*20195 S. Diamond Lake Road, STE 100*

*Rogers, MN 55374*