

ITEM NUMBERS: BRPTL140H, BRPTL160B

MANUAL SERIAL TAG HERE

# Owner's Manual

## Truck Loader Vac:

*This machine is intended for vacuuming leaves, clippings, and other similar sized organic material from the ground into a truck or trailer.*

### WARNING

**READ and UNDERSTAND this manual completely before using truck loader vac.**

All operators of this equipment must read and completely understand all safety information, operating instructions, maintenance, and storage instructions. Failure to properly operate and maintain the truck loader vac could result in serious injury to the operator and bystanders from moving parts that can crush or cut, flying objects, burns, fire or explosion or carbon monoxide poisoning and be aware of the following hazards.

- **WARNING:** Never operate this unit free standing. It must be secured in place before use.
- **DANGER:** Do not operate the truck loader vac near people. Debris can be thrown hundreds of feet. Clear work area of foreign objects and debris. Debris thrown by truck loader vac can cause serious injury or death.
- **CAUTION:** Avoid fires. Keep the machine clean of debris, trash, and any other flammable material.
- **WARNING:** Tighten all nuts and bolts before starting. Replace or repair any safety device, bolts, etc. if damaged or worn.
- **DANGER:** Never operate this unit without the suction hose securely mount to blower housing
- **DANGER:** Stay clear of rotating blades. Keep hands and feet from impeller.
- **DANGER:** Never operate truck loader vac without hose mounted securely.
- **WARNING:** Wear protective clothing. Wear close-fitting clothing and other protective devices appropriate for the job.
- **DANGER:** Keep riders off machine. Riders can be seriously injured or killed by entanglement or by falling.
- **DANGER:** Exercise caution while working near machine. Failure to heed warnings may lead to serious injury or death.
- **DANGER:** Always maintain a safety distance of at least 150 feet. Never operate truck loader vac with bystander's present. The truck loader vac creates a serious discharge hazard.
- **DANGER:** Be aware of the suction power of your Brave Truck Loader, it is capable of vacuuming unwanted material/product.
- **DANGER:** Do not operate if excessive vibration occurs. Shut off engine immediately if excessive vibration occurs. Check impeller for loose impeller bolts, worn impeller, loose impeller key, or other issues that could cause the vibration.

### STOP!

**ADD OIL TO ENGINE BEFORE USING:** Engine is shipped without oil. **DO NOT** start truck loader vac without first adding oil.

**INSPECT COMPONENTS:** Closely inspect to make sure no components are missing or damaged.

See Initial Unpacking and Set-up for instructions and for whom to contact to report missing or damaged parts.

**Any Questions, Comments, Problems or Parts Orders**

**Call BRAVE Product Support 1-800-350-8739**

## Hazard Signal Word Definitions





	<p>This is the safety alert symbol. It is used to alert you to potential personal injury hazards. Obey all safety messages that follow this symbol to avoid possible injury or death.</p>
	<p>DANGER (red) indicates an imminently hazardous situation which, if not avoided, will result in death or serious injury.</p>
	<p>WARNING (orange) indicates a potentially hazardous situation which, if not avoided, could result in death or serious injury.</p>
	<p>CAUTION (yellow) indicates a potentially hazardous situation which, if not avoided, may result in minor or moderate injury.</p>
	<p>CAUTION (yellow) used without the safety alert symbol indicates a potentially hazardous situation which, if not avoided, may result in property damage.</p>

fig01453

## Table of Contents

Important Safety Rules .....	4
Warning Label Locations .....	10
Assembly Instructions.....	11
Machine Component Identification.....	11
Operation Instructions .....	13
Maintenance and Storage.....	21
Troubleshooting .....	23
Specifications .....	24
Parts Exploded View .....	25
Warranty.....	28

# Important Safety Rules

**Thank you for purchasing your Brave Truck Loader Vac!**

## **About Your Truck Loader Vac:**

This truck loader vac is a machine designed for vacuuming leaves, clippings, and other similar sized organic material from the ground into a truck or trailer. Do not feed sand, metal, rocks, bottles, cans or other non-botanical objects and debris into the machine.

## **Owner/Operator/Renter Training**

Read and follow all instructions and safety precautions presented throughout this manual. A summary of important safety information can be found at the end of the manual. Keep this manual for reference and review. **If the owner of this unit is different than the operator, give a copy of this manual to any operator to read.**

## **Rental Companies**

*All persons to whom you rent/loan this truck loader vac must have access to this manual and read it. Advise all persons who will operate the machine to read it. You should also provide personal instruction on how to safely operate the truck loader vac and remain available to answer any questions a renter/borrower might have. If videos are available, have renter watch training video.*

## **Engine Instructions**

For detailed Engine operation and maintenance information, always refer to the engine Owner's Manual furnished with the truck loader vac.

## **Product Suitability**

Before using, the user shall determine the suitability of this product for their intended use and assumes liability therein.

Your Brave truck loader vac can be used to remove debris such as leaves, clippings, and other similar sized organic material from the ground into a truck or trailer. Make sure you completely read and understand this manual before using the truck loader vac for the first time. If you have any questions, contact your retail or rental dealer or BRAVE Customer Service at 1-800-350-8739.

BRAVE is constantly improving its products. The specifications outlined herein are subject to change without prior notice or obligation. The purchaser and/or user shall assume liability for any modification and/or alterations of this equipment from original design and manufacture.

**Contact BRAVE Customer Service at 1-800-350-8739 for any questions about the appropriate use of this truck loader vac or about optional accessories.**

## **Warranty Registration**

Please fill out and submit the warranty registration card so that we have your contact information for any future product literature or replacement parts you may need. Or you can register online at [www.braveproducts.com](http://www.braveproducts.com).

# Important Safety Rules



## READ OWNER'S MANUAL COMPLETELY

Carefully read and make sure you understand the following safety information before using the truck loader. Serious injury or death can result if safety instructions are not followed. Improper use or maintenance of the truck loader can result in serious injury or death from fire/explosion, carbon monoxide poisoning, lacerations, entanglement or burns. Damage can also occur to windows, siding, vehicles, and bystanders from chips and debris which can become projectiles. If the owner of this unit is different than the operator, give a copy of this manual to any operator to read. Read and follow all instructions and safety precautions presented throughout this manual. Keep this manual for reference and review.

## GENERAL

- **Read manual.** Read this Owner's Manual and the engine Owner's Manual completely before attempting to use and service the truck loader vac. Serious injury or death can result if safety instructions are not followed.
- **Instruct operators.** The truck loader vac owner must instruct all operators in safe truck loader vac set-up and operation. Do not allow anyone to operate the truck loader vac who has not read the Owner's Manual and been instructed on its safe use.
- **Adults only.** Only trained adults should operate and service the truck loader vac. Do not let children operate.
- **Under the influence.** Never operate, or let anyone else operate, the truck loader vac while under the influence of alcohol, drugs, or medication.
- **Intended use.** Carefully read about and understand the intended use of this truck loader vac. Do not use for other purposes, as unforeseen hazards or equipment damage may result.
- **Controls and safety labels.** Learn how to use the machine and it's controls safely. Understand and follow all safety labels.
- **Weather.** Never use in foul, bad, or questionable weather, which causes an unsafe condition.
- **Mounting.** Never use unit freestanding. Unit must be secured.
- **Guards.** Never use this equipment with ANY safety features or guards removed.
- **Attended.** Never leave this unit unattended while in operation.
- **Bystanders.** Never operate this equipment with bystanders in the area

## PROHIBITION AGAINST MODIFICATIONS

Never modify or alter the truck loader vac in any way. Modifications can create serious safety hazards and will also void the warranty.

- **Fuel/exhaust system.** Never modify the exhaust system, fuel tanks, or fuel lines. Carbon monoxide poisoning, fire, or explosion could result.
- **Guards.** Do not operate truck loader vac unless all guards and cover shields, which prevent access to moving parts and pinch points, are in place. Failure to guard all moving parts/components *may result in serious injury or death.*

# Important Safety Rules

## SAFETY – BEFORE USE

### Know how to operate.

- **Review safety rules.** Before use of this truck loader vac, review all “Important Safety Rules.”
- **Know how to operate.** Be thoroughly familiar with all controls and with the proper use of the equipment. Know how to stop the truck loader vac quickly if needed.

### Getting Ready

- **Flying debris.** Clear area of objects such as stones, toys, steel wire, etc. that could become caught in moving machine parts and ejected as a projectile. Never direct discharge material toward anyone. Avoid discharging material towards a wall, car, house, or other objects. Material may ricochet back at operator.
- **Operate OUTSIDE only – dangerous carbon monoxide exhaust!** truck loader vac gives off carbon monoxide exhaust, a poisonous gas that can kill. You CANNOT smell it, see it, or taste it. ONLY run truck loader vac OUTDOORS and away from building air intakes. NEVER run truck loader vac engine inside homes, garages, sheds, or other semi-enclosed spaces. These spaces can trap poisonous gases.
- **Bystanders.** Do not operate this equipment near bystanders. Keep area of operation clear of all persons, especially small children. It is recommended that bystanders keep at least 50 feet away from the area of operation.
- **Cooling ventilation.** The truck loader vac needs adequate, unobstructed flow of air to allow for proper cooling of engine and truck loader vac housing. Do not allow debris to accumulate and block airflow.
- **Transporting.** During transporting, take precautions to make sure truck loader vac will not tip over and cause a fuel leak hazard.
- **Hot exhaust - fires.** Exhaust from engine can be extremely hot and cause fire. Position muffler at least 7 feet from combustible objects during operation.
- **Fire extinguisher.** Keep a fire extinguisher rated “ABC” by the National Fire Protection Association nearby is always recommended when using gasoline operated machinery. Keep it properly charged and be familiar with its use.

## SAFETY – DURING USE

- **Safety equipment / controls.** Always operate the truck loader vac with all safety covers, guards, and barriers in place and in good working order, and all controls properly adjusted for safe operation.
- **Know how to stop.** Know how to stop the truck loader vac quickly if needed by Turing the **on/off** switch on engine to **OFF**.
- **Slipping/Falling.** Operating in wet or icy conditions could lead to losing your footing and slipping or falling.
- **Body parts.** Never place hands or feet inside the nozzle intake, debris discharge outlet or near any moving parts while the blades are turning. The truck loader vac can pull you into the blade, causing amputation or other body injury.
- **Damaged.** Do not operate the truck loader vac with damaged, missing, incorrectly adjusted, or broken parts.
- **Check for gas leak before starting.** After opening gasoline valve, smell for gas before starting engine. If you smell gas, DO NOT start engine. DO NOT light a match. DO NOT flip on an electrical switch. Exit area immediately and call fire department.
- **Carbon monoxide exhaust.** The running engine gives off carbon monoxide, a poisonous gas that can kill you. You CANNOT smell it, see it, or taste it. If you start to feel sick, dizzy, or weak while using the truck loader vac, shut off the engine and get to fresh air RIGHT AWAY. See a doctor. You may have carbon monoxide poisoning.

## Important Safety Rules

- **Other exhaust dangers.** This product contains or emits chemicals known to the State of California to cause cancer, birth defects or other reproductive harm. Avoid inhalation of exhaust.
- **Smoking/sparks.** Never smoke near the running truck loader vac, and never operate near sources of sparks or flames.
- **Hot muffler.** Never touch hot muffler or hot exhaust manifold. Exhaust and engine parts can be very hot and will burn you. Never operate engine with grass, leaves or other combustible materials near the muffler
- **Slopes.** Never operate this unit on slopes greater than listed in the specification's sections of this manual.
- **Starting.** Never attempt to start engine without the hose and all safety systems securely in place.
- **Hose.** Never remove hose until engine and all moving parts have stopped.
- **Clogs:** Turn truck loader vac **OFF** and wait for all moving parts to completely stop. Disconnect the spark plug wire before attempting to free any clogged area.
- **Maintenance/Repair:** Turn truck loader vac **OFF** and wait for all moving parts to completely stop. Disconnect the spark plug wire before moving, unclogging, refueling, or performing maintenance or repairs.
- **Starting & Stopping Unit:** Make sure hands, feet and all body parts are clear of intake hose. Make sure the inlet is empty when starting the machine.
- **Machine's moving parts.** Keep hands, feet, and apparel away from moving parts. Never remove any guard while the unit is operating. Contact with rotating impeller will cause personal injury.
- **Refueling.** DO NOT refuel the engine until it has cooled at least two minutes.
- **Worksite.** Set up your work site so you are not endangering people or the surroundings. Ensure work area is marked and section off so bystanders cannot enter.
- **Malfunction during operation.** Always shut the machine off if any unusual noise or vibration occurs.
- **Vibration.** Overexposure to machine vibration on a daily basis may lead to circulatory or nerve damage.
- **Adjusting / repairing.** Always turn off truck loader vac and remove spark plug or spark plug wire before working on the truck loader vac to prevent accidental starting.

### SAFETY – AFTER USE

- **Cool engine before storing.** Let engine cool for at least five minutes before storing. A hot engine can be a fire hazard.
- **Shut off fuel supply.** Make sure gasoline shut-off valve is in the OFF position.
- **Prevent accidental starting.** When truck loader vac is not in use, remove key from starter (electric start engines) and secure in a safe location, or remove spark plug in order to ensure that truck loader vac cannot be started in a storage location or by untrained persons.
- **Storage location.** Store the truck loader vac in a dry location away from sources of heat, open flames, sparks, or pilot lights – such as water heaters, space heaters, furnaces, clothes dryers, or other gas appliances – EVEN IF the truck loader vac's gas tank is empty. Residual gasoline could ignite.

### SAFETY – INSPECTION/MAINTENANCE

Inspect and maintain your truck loader vac on a regular basis and repair as needed to keep it in safe working condition:

- **Turn off** truck loader vac. Always turn off truck loader vac and remove spark plug or spark plug wire before working on the engine or truck loader vac to prevent accidental starting.
- **Replace guards / shields.** Make sure all guards and shields are replaced after servicing the truck loader vac.
- **Burns.** Do not touch hot muffler. Muffler will be hot even if unit is stopped. Allow unit to cool before servicing.

## Important Safety Rules

- **Replacement parts.** If a part needs replacement, only use parts that meet the manufacturer's specifications. Replacement parts that do not meet specifications may result in a safety hazard or poor operation of the truck loader vac and will void the warranty



### Personal protective equipment

- **Hearing protection.** The use of ear plugs, or other hearing protection device is recommended for those in close proximity to the truck loader vac while it is operating.
- **Eye protection.** Wear ANSI approved eye protection when operating the truck loader vac.
- **Face protection.** Wear a full-face visor or mesh visor with protective glasses is recommended.
- **Loose / dangling.** Loose or dangling apparel, jewelry or hair can become entangled in moving parts. Never wear jewelry or loose-fitting clothing when operating the truck loader vac.
- **Long pants.** Wear long, heavy-duty pants to protect legs from ejected materials.



### GASOLINE SAFETY - RISK OF FIRE AND EXPLOSION

Gasoline is highly flammable and explosive. Drain the fuel into an approved container OUTDOORS and far away from open flame. NEVER store an engine with fuel in the tank indoors or in poorly ventilated spaces where fuel vapor can come in contact with static electric sparks sparks from electric wiring, batteries, or running engines sources of heat (such as a hot engine or exhaust) open flames, including pilot lights

Gasoline is highly flammable and explosive. You can be burned or seriously injured when handling fuel. Use extreme care when handling gasoline:

- **Fuel outdoors.** Fill fuel tank outdoors – never indoors. Gasoline vapors can ignite if they collect inside an enclosure. Explosion can result.
- **Use approved container.** Never pump fuel directly into engine at gas station. Static charge can build and ignite fuel. Use an UL approved fuel container to transfer gas to the engine.
- **Running / hot engine.** A running engine is hot enough to ignite fuel. Never add fuel or remove gas cap if engine is running or still hot. Stop the engine and allow to cool at least two minutes before adding fuel.
- **Heat / flames / sparks.** Keep sources of heat, flame, or sparks away while adding fuel.
- **Don't fill to the top** DO NOT overfill the gas tank. Allow at least 1" of empty space below the fill neck to allow for fuel expansion and operation on slopes.
- **Replace cap.** Replace gas cap securely before starting engine.
- **Spills.** Clean up fuel spills immediately. Move truck loader vac away from spilled fuel on the ground. Wipe fuel off engine and wait 5 minutes for excess fuel to evaporate before starting engine. Gas-soaked rags should be disposed of properly.
- **On skin / clothes.** If gasoline is spilled on your skin or clothes, change clothes and wash skin immediately.
- **Inspect fuel system.** Check fuel system on a regular basis. Look for signs of leaks, damaged fuel tank, cracked hose or a defective fuel shut-off valve. Do not start truck loader vac until needed repairs have been completed.

## Important Safety Rules

- **Gasoline storage.** Store gasoline in a cool, dry place in an UL-approved, tightly sealed container away from children.

### SPECIAL SAFETY INFORMATION ON STATIC ELECTRICITY

#### Static electricity and filling gasoline:

**Static electricity can initiate from ungrounded gasoline tanks or containers, from flowing gasoline, and from persons carrying a static electric charge.**

Static electricity on numerous occasions has explosively ignited gasoline vapors that were present during fueling processes, resulting in serious burns to nearby persons. To avoid static electricity while fueling, certain steps must be followed before and during the fueling process in order to minimize and safely dissipate static charge build-up.

#### Filling Portable Containers at Service Stations:

**Use a portable container to fill truck loader vac tank. Never fill the truck loader vac gas tank directly from the service station's fuel dispenser pump – the truck loader vac tank is not grounded and the high velocity flow of gasoline from a fuel pump can cause static electric build-up. Use an approved portable container to transfer gasoline to the truck loader vac tank.**

- **Use a portable container made of metal or conductive plastic.** It will dissipate charge to ground more readily.
- **Fill container on the ground. Never fill the portable gas container while it is sitting inside a vehicle, trailer, trunk, or pick-up truck bed. ALWAYS place container on the ground to be filled.**
- **Touch a grounded metal object before starting. Always dissipate static charge from your body before beginning the fueling process by touching a grounded metal object at a safe distance away from fuel sources.**
- **Keep nozzle in contact with container. Keep fuel dispenser nozzle in contact with the portable container at all times while filling at a service station. Do not use the nozzle lock-open device on the dispenser hose.**

#### About static electricity and fueling

Many common objects can accumulate and retain a static electric charge. Objects made of non-conductive materials (e.g., plastics) easily accumulate and retain static electric charge, as can objects made of conductive material (e.g., metal, water) if they are not electrically grounded. The static electric charge on an object, such as a human body or plastic fuel tank/container, can reach as high as several thousand volts!

A static electric spark can be generated if the static electric charge stored on an object "jumps" to another, less charged object. Such a spark can ignite invisible gasoline vapors that are present during fueling situations.

#### Typical sources of static electric hazards during fueling.

The following objects can accumulate a static electric charge and cause an ignition spark in typical fueling situations:

- Ungrounded tanks/containers. Any ungrounded fuel tank or container can accumulate a static electric charge as a result of contact with other objects or friction during transportation. This static electricity can discharge as a spark to the grounded gasoline dispenser nozzle, as the nozzle is first brought close to the tank/container at the beginning of the fueling process.
- Flowing gasoline. Most people are not aware that gasoline accumulates static electric charge while flowing through a hose or pipe. This charge then transfers to and accumulates in the gas tank or container that is being filled. The total amount of charge accumulation depends on the amount of gas pumped into the container, the speed with which it is pumped, and whether or not the tank/container is grounded. If sufficient static electric charge accumulates in the fuel tank or container during the fueling process, the tank/container may discharge a spark to the grounded gasoline dispenser nozzle.
- Persons. A person dispensing the gasoline can carry a static electric charge on their body, typically resulting from contact with their car seat or electronics. The static electricity can discharge as a spark between that person's hand and either the grounded dispenser nozzle or the fuel tank opening.

**Save These Instructions**

# Warning Label Locations

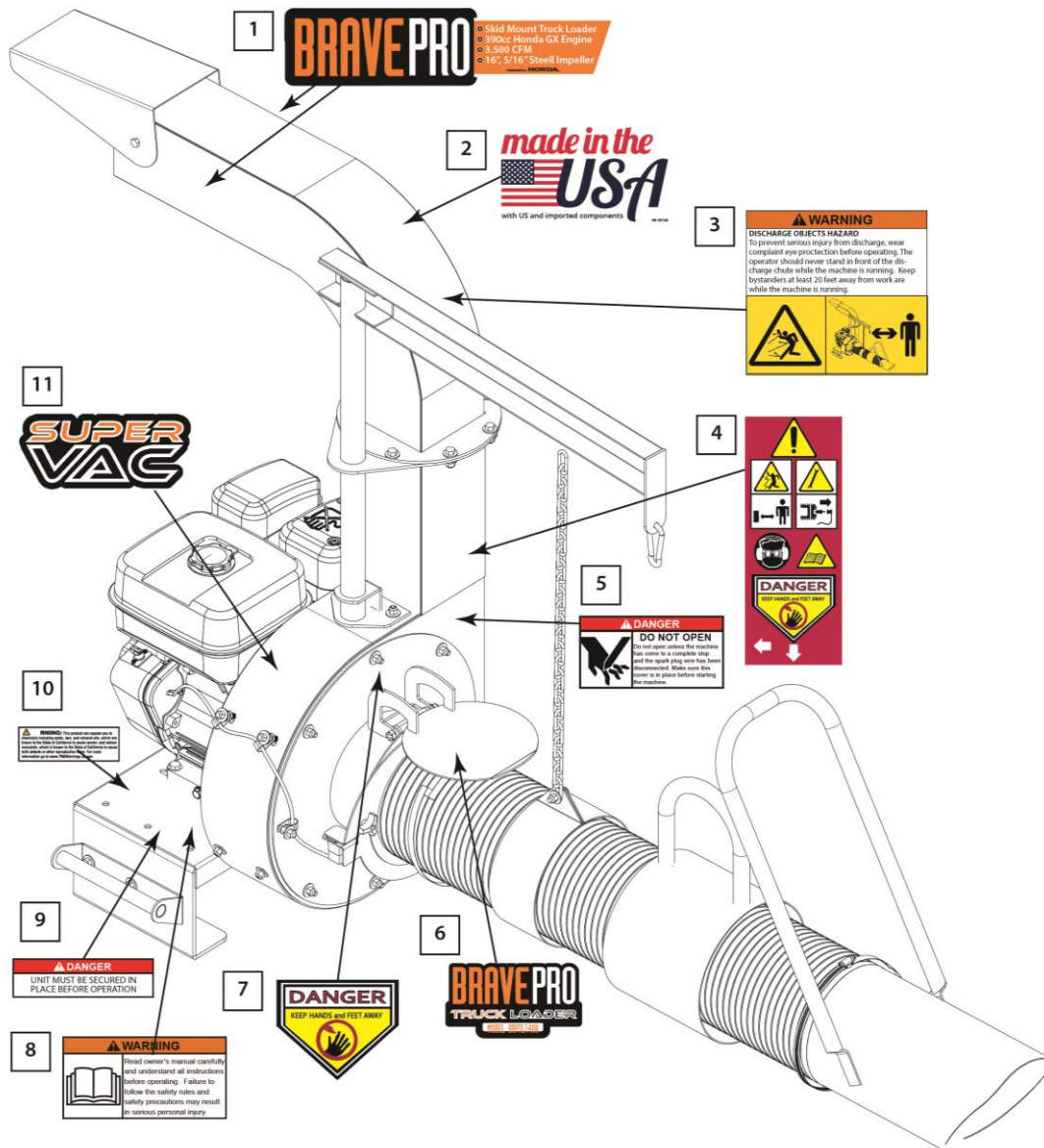

Reference #	Part #	Description
Decal Sheet Set	ZUBRPTL140H ZUBRPTL160B	Decal Sheet Set – BRPTL140H Honda Model Decal Sheet Set – BRPTL160B Briggs Model <i>Sheet Sets Include:</i> <i>Ref. 1 – BravePro Branding Decal for Discharge Chute</i> <i>Ref. 2 – Made in USA</i> <i>Ref. 3 – Warning, Objects Hazard</i> <i>Ref. 5 – Do Not Open</i> <i>Ref. 6 – Brave Pro Branding Decal for Hose Cover</i> <i>Ref. 8 – Warning, Read Owner's Manual</i> <i>Ref. 9 – Danger, Secure Before Transport</i> <i>Ref. 10 – Prop 65</i>
4	1100-074	Truck loader Safety Decal
7	12133	Danger – Keep hands and feet away

## WARNING

ALWAYS make sure safety labels are in place and in good condition. If a safety label is missing or not legible, order new labels. To order replacement safety decals contact BRAVE Customer Service at 1-800-350-8739

# Assembly Instructions

## I.) Unpack.

Your truck loader vac is shipped fully assembled except for a few components: Exhaust Chute, Nozzle, Floating Collar, Hose Support Collar, Hose Support Boom, Hose Clamps, and Misc. Hardware.

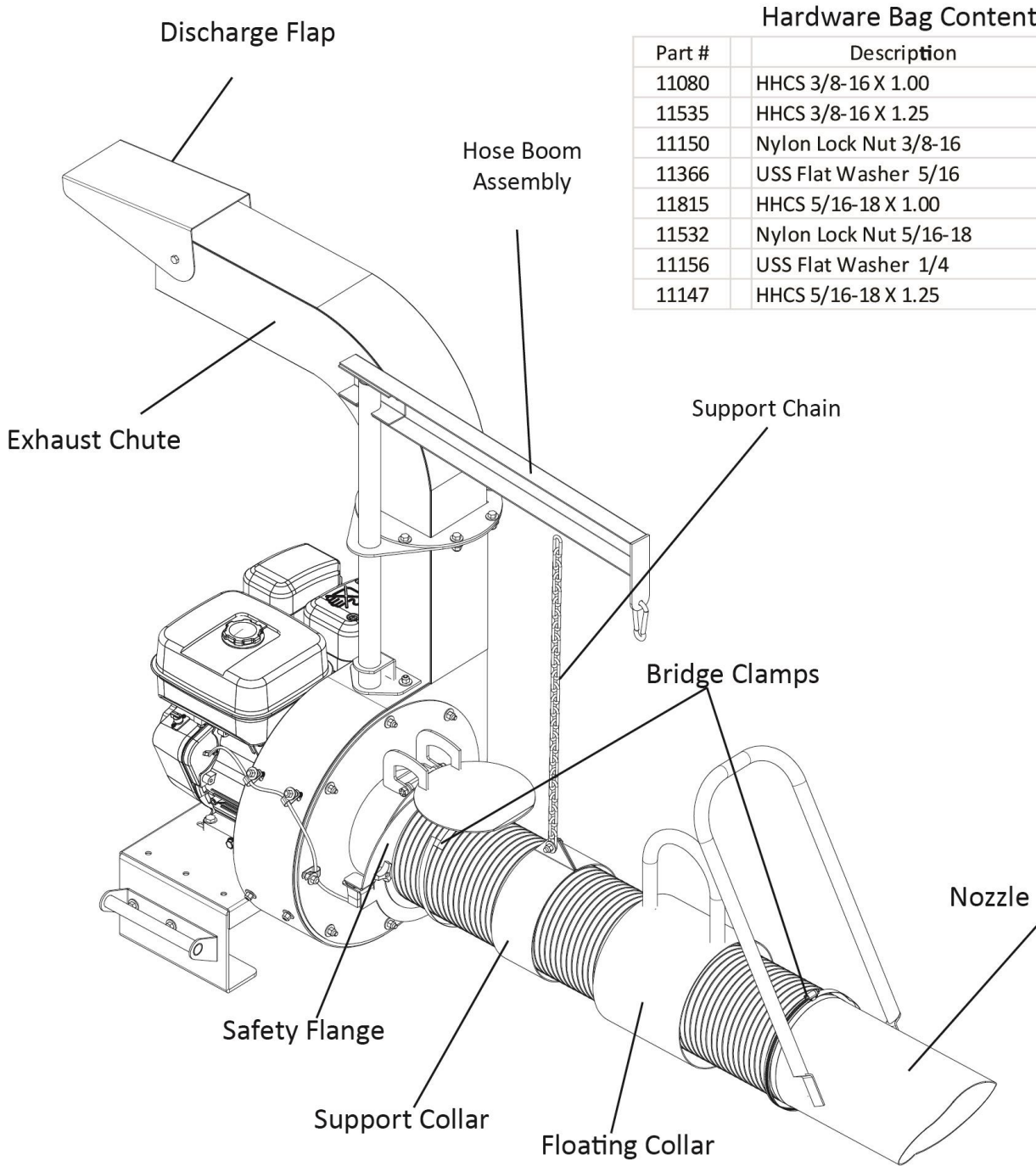

### Hardware Bag Contents

Part #	Description	Quantity
11080	HHCS 3/8-16 X 1.00	2
11535	HHCS 3/8-16 X 1.25	8
11150	Nylon Lock Nut 3/8-16	10
11366	USS Flat Washer 5/16	26
11815	HHCS 5/16-18 X 1.00	3
11532	Nylon Lock Nut 5/16-18	4
11156	USS Flat Washer 1/4	2
11147	HHCS 5/16-18 X 1.25	1

**Any Questions, Comments, Problems or Parts Orders**

***Call BRAVE Product Support 1-800-350-8739***

# Assembly Instructions

## **Intake Hose Assembly**

- 1.) On one end of the hose, slide on the floating collar (#12387) and attach the nozzle (12386) using the bridge clamp (#12406). Securely fasten the clamp.
- 2.) On the other end of the hose, slide the support collar over the hose and attached the safety flange (#12389) to the hose using the bridge clamp (#12406)

## **Exhaust Chute Assembly**

- 3.) Attach exhaust chute (#12398) to the top of the loader housing and secure with 8 bolts, washer, and nuts.
- 4.) Install the discharge flap (#12399) and secure with the supplied hardware.

## **Safety Flange Assembly**

- 5.) Attach safety flange (#12389) to the front of the truck loader vac housing using the two phenolic securing knobs.
- 6.) Carefully stretch the hose and secure the support collar (#12388) at a point where the chain dangles to the hose.

## **Hose Support Boom Assembly**

- 7.) Assemble hose support boom/hanger arm (#12403) and attach support chain (#12411) to hose support boom.

## **Truck Loader Vac Mounting**

- 8.) This unit MUST be securely fastened to a trailer, or truck bed so the exhaust discharges into an enclosed container. This truck loader vac MUST be securely mounted prior to and during all operation and assembly. The unit is not intended to be operated free standing and will create an unsafe situation if attempted. The loader must be secured using 3/8" bolts with washers and lock nuts.

# Operation Instructions

## Pre-start Check List & Procedures

**⚠ CAUTION:**

Add engine crankcase oil. A new engine is shipped without oil. You must add the correct amount of oil to engine crankcase or engine will be damaged beyond repair.

Before starting the engine, you will want to make sure you have completed the following:

1. **Checking Controls**
2. **Checking/Adding Oil**
3. **Filling Truck Loader Vac Gasoline Tank**
4. **Inspecting Fuel System for Leaks**
5. **Wearing Personal Protection**
6. **Ensuring unit is securely mounted**
7. **Clearing Area of People and Objects**
8. **Working During Daylight**

Each of these procedures is discussed in detail below.

**Check controls.**

**Check that:**

- All guards are in place and tight.
- Inspect hose mounting flange to blower housing safety switch, insure it is operational.
- Throttle lever operates freely.
- Inspect suction hose for damage.
- Hose hanger moves freely

**Check/add oil**

**Check the oil level using the dipstick and add oil as needed daily.**

Using a funnel, add oil up to the FULL mark on the dipstick with the recommended oil type for your engine and expected ambient conditions. (See engine Owner's Manual for oil type and capacity, and more detailed oil check/fill instructions.)

**⚠ WARNING: Burn hazard**

Never open oil fill port while engine is running. Hot oil can spray over face and body.

# Operation Instructions

<p><b>Fill truck loader vac gasoline tank</b></p>	<p>Check the gasoline level in the truck loader vac fuel tank. If needed, fill tank with fresh unleaded gasoline from a portable container, after first reading the warnings and instructions below.</p> <ul style="list-style-type: none"> <li>- Do NOT fill the gas tank to the top. Gasoline may spill when operating on a slope.</li> <li>- Do NOT overfill the gasoline tank. Allow at least 1” of empty space below the fill neck to allow for fuel expansion.</li> </ul> <p><b>⚠WARNING: Gasoline fire/explosion hazard</b> Gasoline is highly flammable and explosive. Heat, sparks, and flames can ignite gasoline vapors, which can become widespread during fueling. A flash fire ignition and/or explosion could result and cause serious injury or death. The following conditions could result in gasoline ignition/explosion:</p> <ul style="list-style-type: none"> <li>• gas vapor collection inside enclosures</li> <li>• static electric sparks</li> <li>• sparks from electric wiring, batteries, or running engines.</li> <li>• sources of heat (such as a hot engine or exhaust)</li> <li>• open flames, including pilot lights</li> </ul>
<p><b>Inspect Fuel System / Check for Leaks</b></p>	<p style="text-align: center;">Inspect fuel system &amp; check for leaks BEFORE starting truck loader vac.</p> <p><b>⚠WARNING: Fuel leak hazard</b> A leaking fuel line no matter how small the source of a fire or explosion can be when starting or operating the engine.</p> <ul style="list-style-type: none"> <li>• Inspect the entire fuel system. <i>Look for:</i> Signs of leaks, damaged fuel tank, cracked hose or a defective fuel shut-off valve. Do not start truck loader vac until needed repairs have been completed.</li> </ul> <p><b>If truck loader vac is in an enclosed area and you smell gas, DO NOT start engine!</b> DO NOT light a match. DO NOT flip on an electrical switch. Exit area immediately leaving doors open and call fire department.</p>
<p><b>Personal Protection</b></p>	<p><b>Use approved protective clothing and approved protective equipment when using the machine.</b></p> <ol style="list-style-type: none"> <li>1) <b>Always wear ANSI-approved and OSHA-compliant safety glasses with side shields and a full-face shield.</b></li> <li>2) <b>The use of ear plugs, or other hearing protection device is also recommended</b> for persons working within 15-20 feet of the running truck loader vac for longer than a few minutes. Hearing can be damaged from prolonged, close-range exposure to the type of noise produced by this truck loader vac.</li> </ol>

## Operation Instructions

	<p>3) <b>Wear long pants to protect legs from sparks, hot engine and flying debris.</b></p> <p>4) <b>Never wear jewelry or loose-fitting clothing when starting or operating the truck loader vac or any mechanical device.</b> Loose or dangling apparel, jewelry or hair can become entangled in moving parts.</p>
<b>Ensuring unit is securely mounted</b>	Never operate unit free standing. Unit needs to be mounted securely to truck or trailer before use.
<b>Clearing Area of People and Objects</b>	Never direct discharge material toward anyone. Avoid discharging material towards a wall, car, house, or other objects. Material may ricochet back at operator.
<b>Work During Daylight Hours</b>	Only use the machine in daylight or in well-lit conditions. Never operate the truck loader vac after dark.

### Starting the Truck Loader Vac

After you have completed the pre-start checklist and procedures, you are ready to start the truck loader vac.

The following directions detail how to start the engine of your truck loader vac.

**⚠ WARNING:**

Never attempt to use the truck loader vac without proper protective equipment, particularly eye protection and a full-face shield.

**To start the truck loader vac:**

Note: For additional engine starting instructions see your engine manual.

**⚠ WARNING:**

**Never leave truck loader vac unattended.**

- 1) Turn the On/Off Engine Switch to the ON position located on engine.
- 2) For cold engine, Place the choke in the closed/on choke if engine is cold. If engine is hot, do not use choke.
- 3) **A) Pull Start:** Rapidly pull "Start" cord (recoil starter) with right hand several times until engine starts. Allow starter cord to return slowly.  
**B) Electric Start:** Turn Key switch to the START position and hold until the engine starts.

# Operation Instructions

## Vacuuming Operation & Safety

- When operating, engine should run at full RPM.
- Using a sweeping motion, point hose inlet towards debris and sweep back and forth to remove debris.
- Keep hand, feet, and body parts away from hose inlet, discharge chute and any moving parts.
- Keep hose straight and avoid sharp bends in hose during use. This will prevent clogs.
- Keep nozzle close to debris while using a sweeping motion, but do not bury or block the air flow of the nozzle.
- Before shutting unit off, run and evacuate the entire system, hose, and blower housing

## Stopping the Engine

### Stop the engine using the following steps:

1. Turn the On/Off engine switch to OFF position located on engine.
2. Allow the engine to cool for at least 5 minutes before moving to storage or transporting. A hot engine can be a fire hazard.

## Unclogging Unit

### Unclogging hose: If decreased suction is present, there may be a blockage in hose.

1. With engine running and securely mounted, stretch hose out fully to dislodge.
2. If the hose does not clear the clog by stretching, you will need to turn **OFF** engine and wait for impeller to **STOP** completely.
3. Disconnect spark plug wire and battery cables if applicable.
4. Remove the hose assembly. Wearing gloves, clear any debris that is clogging the hose.
5. Once clog is cleared, reassemble, and reconnect the spark plug wire to resume operation.

### Unclogging Housing or Exhaust Chute: If decreased suction is present, there may be a blockage.

1. Turn engine OFF.
2. Wait for impeller to completely **STOP**.
3. Disconnect spark plug wire and battery cables if applicable.
4. Remove the hose assembly from housing to locate clog.
5. If possible clear clog from housing intake opening.

## Operation Instructions

6. If clog is present in discharge chute, carefully remove chute. Note this is heavy, please use caution removing. Wear gloves, clear debris clogging chute.
7. Once clog is cleared, reassemble, and reconnect the spark plug wire and battery cables if applicable to resume operation.

**⚠ CAUTION:**

Caution should be used when clearing the clogged debris. Always wear gloves. Sharp edges on the impeller or objects maybe be present.

### Refueling

- 1) Before removing gas cap, turn engine off and allow to cool for at least two minutes.

*Note:* A running, or hot engine can ignite fuel.

- 2) Remove gasoline cap.
- 3) Add gasoline through the fill opening:
  - Use only an UL-approved portable gasoline container to transfer the gasoline to the truck loader vac's tank.
  - Be aware of safety warning and instructions below for avoiding static electric caused fires.

**⚠ WARNING:**

**Static electric spark hazard**

A static electric spark can explosively ignite gasoline vapor, resulting in a flash fire that could cause serious injury or death. See "Special Safety Information on Static Electricity" in this manual.

- 4) Clean up gasoline spills /splashes immediately.
  - If possible, move the truck loader vac away from spilled gasoline on the ground.
  - Wipe up spilled gasoline and wait 5 minutes for excess gasoline to evaporate before starting engine.
  - Gasoline-soaked rags are flammable and should be disposed of properly.
  - If gasoline is spilled on your skin or clothes, change clothes and wash skin immediately.
- 5) Replace gasoline cap securely before starting engine.
- 6) Store extra gasoline in a cool, dry place in an UL-approved, tightly sealed container.
- 7) Filling towable units or portable containers at service stations:

Even if you have a towable unit, avoid static electric sparking while filling the gasoline tank:

- Never fill the truck loader vac's gas tank directly from the fuel pump. The truck loader vac's tank is not grounded and high velocity flow from the pump can cause static electricity build-up. Use an approved portable container to

## Operation Instructions

transfer gas to the truck loader vac's tank.

- Use a portable container made of metal or conductive plastic. This is preferred because it dissipates static charge to ground more readily.
- Never fill a portable gas container while it is sitting inside a vehicle, trailer, trunk, or pick-up truck bed. ALWAYS place container on the ground to be filled.
- Keep nozzle in contact with container while filling. Do not use a nozzle lock-open device.

### Storing the Truck Loader Vac

**When you are finished using the truck loader vac and it has cooled, you must:**

- Cool engine before storage.
- Clean the truck loader vac.
- Inspect for worn or damaged parts.
- Choose covered storage location.
- Prevent accidental starting.
- Plan on exercising the engine at least monthly unless the truck loader vac is prepared for long-term storage.

Detailed instructions are provided below.

<b>Cool engine</b>	<b>Let engine cool for at least five minutes before storing.</b> A hot engine can be a fire hazard.
<b>Clean truck loader vac</b>	<b>Clean all grease, dirt, mud, and other foreign matter from the machine. Touch up paint damage to prevent rust.</b>
<b>Inspect truck loader vac</b>	<b>Inspect the machine for worn or damaged parts and tighten any nuts or screws that may have become loose. Pay particular attention to the impeller.</b>
<b>Choose a storage location</b>	<b>Store the truck loader vac in a location that is:</b> <ul style="list-style-type: none"> <li>○ Clean and dry</li> <li>○ Away from sources of heat, open flames, sparks, or pilot lights, even if the truck loader vac's gas tank is empty. Residual gasoline could ignite.</li> <li>○ Away from extreme high or low temperatures.</li> <li>○ Cover it for extra protection</li> </ul>
<b>Remove key</b>	<b>Remove key from starter and secure key in a safe location, or remove</b>

# Operation Instructions

	<p><b>spark plug</b>, in order to ensure the truck loader vac cannot be started in a storage location or by untrained persons or children.</p>
<p><b>Start truck loader vac every 4 weeks</b></p>	<p><b>The truck loader vac should be started regularly.</b> At least every four weeks, start the engine and let it run for 10 to 15 minutes.</p> <p>Monthly exercising of the truck loader vac will dry out any moisture that has accumulated, lubricate cylinders, and clean out old gas in the carburetor. Moisture, old gas, and dry mechanical parts cause deterioration in stored engines.</p>
<p><b>Prepare engine for long term (seasonal) storage if needed</b></p>	<p><b>If you will not be able to start the truck loader vac regularly, you must prepare the engine for long term storage</b> to prevent gum deposits from forming and causing malfunction of the engine.</p> <p>Prepare engine for long term storage by:</p> <ul style="list-style-type: none"> <li>○ <b>Removing all gasoline</b> from the tank and carburetor</li> <li style="text-align: center;"><u>OR</u></li> <li>○ <b>Adding fuel stabilizer</b> to the gasoline (following manufacturer's instructions)</li> </ul> <p style="margin-left: 40px;"><u>Fuel stabilizer steps:</u></p> <ol style="list-style-type: none"> <li>1. Ensure gas tank is full.</li> <li>2. Add fuel stabilizer to fuel tank.</li> <li>3. Run engine at least 10 minutes after adding stabilizer to allow it to enter the fuel system.</li> <li>4. Shut off engine.</li> <li>5. Disconnect spark plug wire and remove spark plug.</li> <li>6. Add one teaspoon oil through spark plug hole.</li> <li>7. Place rag over spark plug hole and turn starter (or pull the recoil) a few times to lubricate the combustion chamber.</li> <li>8. Replace spark plug, but do not reconnect the spark plug wire.</li> </ol> <div style="background-color: #e0e0e0; padding: 10px; margin-top: 20px;"> <p><b>⚠ WARNING: Gasoline fire/explosion hazard</b></p> <p>Gasoline is highly flammable and explosive. Drain the fuel into an approved container OUTDOORS and far away from open flame. NEVER store an engine with fuel in the tank indoors or in poorly ventilated spaces where fuel vapor can come in contact with</p> <ul style="list-style-type: none"> <li>• static electric sparks</li> <li>• sparks from electric wiring, batteries, or running engines</li> <li>• sources of heat (such as a hot engine or exhaust)</li> <li>• open flames, including pilot lights</li> </ul> </div>

# Operation Instructions



## WARNING

ALWAYS shut off the engine, make sure the engine is cool, and disconnect the spark plug before cleaning, adjusting, or servicing the truck loader vac. Make sure all guards and shields are replaced before using.

## Hose Care

**The hose is a replaceable wear item and care should be given to ensure a long hose life.**

To maintain and increase the life of your hose, rotate hose and reposition nozzle and collar periodically. Avoid wearing one side by rotating during use.

Keep hose in good condition by never dragging, avoid sharp bends, and keep hose as straight as possible to avoid clogs and for best suction. Always remove the hose and store safely before transporting truck loader vac. Storing hose in a straight and flat manner will help to maintain its flexibility.

## Battery Maintenance (when applicable)

**Maintain and extend the life of your battery with proper maintenance care.**

- Do not run the battery charge down too low.
- Store unused battery in cool, dry area. Do not allow to freeze.
- If not being used, charge the battery every 4 weeks.
- Do not overcharge battery. If battery is fully charged do not charge.
- When battery is low, do not continue to crank engine.
- Operate engine for at least 45 minutes to maintain a properly charge battery.
- Use a trickle charger if the battery loses its charge to recharge it. Be sure to check your battery and charger to ensure compatibility. Using a charger with higher amps will cause damage to battery.
- Disconnect battery from charger once charged.

# Maintenance and Storage

<b>Maintenance</b>	
<b>Perform regular maintenance</b>	<b>Perform periodic maintenance</b> as directed in this manual to keep the truck loader vac in safe working condition.
<b>Follow safety rules</b>	<p><b>Read and follow these safety rules whenever you will be servicing the truck loader vac:</b></p> <ul style="list-style-type: none"> <li>• <b>Turn off truck loader vac.</b> Always turn off truck loader vac and remove spark plug or spark plug wire and disconnect battery on electric start models before working on the engine or truck loader vac to prevent accidental starting.</li> <li>• <b>Replace guards/shields.</b> Make sure all guards and shields are replaced after servicing the truck loader vac.</li> <li>• <b>Burns.</b> Muffler will be hot even after unit is stopped. Allow unit to cool before servicing.</li> <li>• <b>Repair.</b> Major service, including the installation or replacement of parts, should be performed only by a qualified service technician. Obtain factory approved parts from Brave Service at 1-800-350-8739.</li> <li>• <b>Replacement parts.</b> If a part needs replacement, only use factory approved repair parts. Replacement parts that do not meet specifications may result in a safety hazard or poor operation of the truck loader vac and will void the warranty.</li> </ul>
<b>Perform engine maintenance</b>	<p><b>Perform engine maintenance as specified in the engine owner's manual.</b></p> <p>Engine maintenance items include:</p> <ol style="list-style-type: none"> <li>1. Change Oil and oil filter (if applicable)</li> <li>2. Air filter check/replacement</li> <li>3. Spark plug cleaning and replacement</li> <li>4. Fuel tank cleaning.</li> </ol>
<b>Inspect fuel system / check for leaks</b>	<p><b>Inspect the fuel system and check for leaks on a regular basis.</b></p> <p>Look for signs of leaks, damaged fuel tank, cracked hose or a defective fuel shut-off valve. Do not start truck loader vac until needed repairs have been completed.</p>

## Maintenance Mode

Before performing any maintenance on the truck loader vac, it must be placed in maintenance mode.

- 1.) Turn off engine.
- 2.) Shut off fuel valve.
- 3.) Unplug spark plug wire from spark plug, (see engine owners' manual).

# Maintenance and Storage

## Maintenance Schedule

Component	Maintenance Required	Refer to Engine Operator Manual	Before Each Use	Every 8 Hours	Every 20 Hours
Engine Oil	Check/Fill/Change Oil	✓	✓		
Fuel Filter	Replace	✓			
Spark Plug	Check condition & gap	✓			
Air Filter Element	Clean or replace	✓		✓	
Hose Mount Safety Switch	Check to make certain it's in working order		✓		
Hose & Hose Bands	Check Condition & Tighten Bands				✓
Clean Engine of Debris	Blow off, clean all debris from engine		✓		
Evacuate System	Clean out blower housing and hose		✓		
Impeller	Inspect Impeller for damage				✓
All fasteners	Check & Tighten as needed			✓	

## Long Term Storage

Follow the engine owner's manual for storing the engine.

## Winter Storage

See page 20 for long term storage.

# Troubleshooting



## WARNING

Turn OFF machine and wait for all moving parts to come to a complete STOP. Disconnect the spark plug wire before proceeding with any repairs, maintenance, unclogging, refueling.

<b>Problem</b>	<b>Possible Cause</b>	<b>Solution</b>
Engine will not start	<ol style="list-style-type: none"> <li>1. No Fuel</li> <li>2. Low quality/deteriorated, old gasoline.</li> <li>3. Spark plug cap is not connected securely.</li> <li>4. Dirty fuel passageways</li> <li>5. Low engine oil</li> </ol>	<ol style="list-style-type: none"> <li>1. Add fuel.</li> <li>2. Use fresh unleaded gasoline.</li> <li>3. Connect spark plug cap properly.</li> <li>4. Clean out passageways using a fuel additive. Heavy deposits may require further cleaning.</li> <li>5. Add engine oil to proper level.</li> </ol>
Excessive Vibration	<ol style="list-style-type: none"> <li>1. Loose, damaged, or out of balance impeller</li> </ol>	<ol style="list-style-type: none"> <li>1. Inspect impeller for damage. Replace if necessary.</li> </ol>
Vacuum Not Working/Loss of Suction	<ol style="list-style-type: none"> <li>1. Hose is not attached properly.</li> <li>2. Engine is not running at full RPM.</li> <li>3. Clogged Hose</li> </ol>	<ol style="list-style-type: none"> <li>1. Connect hose properly.</li> <li>2. Set throttle control to FAST if equipped.</li> <li>3. Unclog hose. See Unclogging hose section in manual. Must turn engine <b>OFF</b></li> </ol>
Engine is locked	<ol style="list-style-type: none"> <li>1. Debris is clogged against impeller not allowing it to turn.</li> </ol>	<ol style="list-style-type: none"> <li>1. Unclog. See Unclogging hose section in manual. Must turn engine <b>OFF</b></li> </ol>
Engine Runs but nothing discharges from chute	<ol style="list-style-type: none"> <li>1. Discharge chute or hose is clogged.</li> <li>2. Engine is not running at full RPM</li> </ol>	<ol style="list-style-type: none"> <li>1. Unclog hose or chute. See Unclogging section in manual. Must turn engine <b>OFF</b>.</li> <li>2. Set throttle control to FAST if equipped</li> </ol>

## Specifications

Model:	<b>BRPTL140H</b>	<b>BRPTL160B</b>
Engine:	Honda GX390	Briggs & Stratton
Mounting	Skid Mount	Skid Mount
Fuel Type	Gas	Gas
Engine: Fuel Capacity	6.9 qt.	9 qt.
Engine: Oil Capacity	1.16 qt.	1.75 qt.
Loader Vac Total Weight	244 lbs.	337 lbs.
Maximum Operating Slope	25 Degrees	25 Degrees
Dimensions H x W x L	47" x 22" x 26"	49" x 29" x 34"
CFM	3,500	4,400
Intake Hose	8" x 10' Clear Urethane	10" x 10' Clear Urethane
Discharge	5.75" x 5.75"	7" x 7"
Starter	Recoil	Electric/Recoil
Impeller	5/16" Steel	5/16" Steel
Shredding	Yes, up to 12:1	Yes, up to 12:1
Diameter	16"	18"
Engine Shaft Connection	Bored to Size	Taper Lock Hub
Replaceable Housing Liner	12 Gauge Steel	11 Gauge Steel
Battery (Elec Models Only)	N/A	Battery Not Included (Battery Group U1)

The manufacturer reserves the right to make improvements in design and/or changes in specifications at any time without incurring any obligation to install them on units previously sold.

**Any Questions, Comments, Problems or Parts Orders**

***Call BRAVE Product Support 1-800-350-8739***



# Exploded Parts View

BRPTL140H - Honda Model Debris Loader				BRPTL160B - Briggs Model Debris Loader			
Item	QTY	Part #	Description	Item	QTY	Part #	Description
1	1	BR12386	Hose Nozzle w/Handle	1	1	BR12467	Hose Nozzle w/Handle
2	1	BR12387	Floating Handle	2	1	BR12469	Floating Handle
3	1	BR12388	Support Collar	3	1	BR12471	Support Collar
4	1	*12411	Support Chain - 26 Links	4	1	*12411	Support Chain - 26 Links
5	1	BR12389	Hose Ring Flange	5	1	BR12454	Hose Ring Flange
6	1	BR12391	Safety Plate Assembly	6	1	BR12453	Safety Plate Assembly
7	1	BR12390	Intake Assembly	7	1	BR12452	Intake Assembly
8	1	*12370	Interlocking Switch	8	1	*12370	Interlocking Switch
9	1	12405	8' Intake Hose (Heavy Duty)	9	1	12445	10' Intake Hose (Heavy Duty)
10	1	12393	Impeller	10	1	12458	Impeller
11	1	12392	Shark Blade (Shredder)	11	1	12466	Shark Blade (Shredder)
12	1	BR12396	Housing	12	1	BR12456	Housing
13	1	*BR12400	Hanger Support Plate	13	1	*BR12400	Hanger Support Plate
14	1	*BR12403	Hanger Arm Assembly	14	1	*BR12403	Hanger Arm Assembly
15	1	*1092	Adjustable Snap Clip	15	1	*1092	Adjustable Snap Clip
16	1	BR12398	Chute Assembly	16	1	BR12450	Chute Assembly
17	1	BR12399	Discharge Flap	17	1	BR12451	Discharge Flap
18	1	BR12404	Engine Spacer	18	1	BR12462	Engine Spacer
19	1	*1100-012	.250" Key Stock	19	1	*1100-012	.250" Key Stock
20	1	12416	Safety Interlock Wiring Harness	20	1	12472	Safety Interlock Wiring Harness
21	1	Engine	Model Specific	21	1	Engine	Model Specific
22	1	BR12394	Motor Base	22	1	BR12457	Motor Base
23	1	BR12395	Base Handle	23	1	BR12455	Base Handle
24	2	12406	8" Bridge Clamp	24	2	12446	10" Bridge Clamp
25	2	12407	Quick Release Knob	25	2	*12407	Quick Release Knob
26	4	11149	Bolt, 3/8-16 x 1.750" HHCS	28	5	11815	Bolt, 5/16-18 x 1.000" HHCS
28	3	*11815	Bolt, 5/16-18 x 1.000" HHCS	29	1	12447	Bolt, 7/16-20 x 1.50" HHCS Gr8 YZ
29	1	12409	Bolt, 3/8-24 x 2.25" HHCS Gr8 YZ (Impeller)	31	1	11147	Bolt, 5/16-18 x 1.250" HHCS
30	4	11395	Bolt, 3/8-16 x 2-1/2" HHCS	32	1	12426	Cord Grip Strain Relief
31	1	*11147	Bolt, 5/16-18 x 1.25" HHCS, Gr5	34	4	*11709	Bolt, Carriage, 5/16-18 x 1"
33	4	11709	Bolt, Carriage, 5/16-18 x 1"	35	11	12001	Bolt, Carriage, 5/16-18 x 3/4"
34	3	12408	Bolt, Carriage, 1/4-20 x 1"	38	57	*11366	Washer, 5/16" USS
35	8	*12001	Bolt, Carriage, 5/16-18 x 3/4"	40	18	*11150	Nut, 3/8-16 Nylon Lock
36	3	11845	Washer, 1/4"	41	25	*11905	Nut, 5/16-18 Nylon Lock
37	4	11155	Washer, 3/8" Flat	42	3	11914	Bolt, 5/16-18 x 1.750" HHCS
38	57	*11366	Washer, 5/16" USS	43	2	12242	Bolt, 5/16-18 x 2.00" HHCS
39	5	11525	Washer, 3/8" Split Lock	46	3	*12435	Strain Relief Metal Cable Clamp
40	18	*11150	Nut, 3/8-16 Nylon Lock	47	1	12463	Replaceable Wear Liner, 11 Gauge

## Exploded Parts View

							Steel
41	25	*11905	Nut, 5/16-18 Nylon Lock	48	14	*11535	Bolt, 3/8-16 x 1.25" HHCS
42	3	11151	Nut, 1/4-20 Nylon Lock	50	4	12447	Bolt, 7/16-14 x 1-1/2" HHCS
46	3	*12435	Strain Relief Metal Cable Clamp	51	1	*12422	Bolt, 5/16-18 x 4.00" HHCS
47	1	12417	Replaceable Wear Liner, 12 Gauge	52	1	12478	Muffler Heat Shield
48	14	*11535	Bolt, 3/8-16 x 1.25" HHCS	54	4	12448	Washer, 7/16 Split Lock
51	1	*12422	Bolt, 5/16-18 x 4.00" HHCS	55	4	12468	Washer, 7/16" USS
				57	1	12441	Bushing, 1-1/8 Taper Lock
				58	1	12460	Battery Hold Down.
				59	1	12465	Terminal protector -RED
				60	1	12464	Terminal protector -BLACK
				61	1	12443	Cable, Bare Copper, Battery, Red
					1	12444	Cable, Bare Copper, Battery, Black

***\*Indicated parts used  
on both machines***



**Dear Valued Customer:**

The Brave product you just purchased is built with the finest material and craftsmanship. Use this product properly and enjoy the benefits from its high performance. By purchasing a Brave product, you show a desire for quality and durability. Like all mechanical equipment this unit requires a due amount of care. Treat this unit like the high-quality piece of machinery it is. Neglect and improper handling may impair its performance.

Thoroughly read the instructions and understand the operation before using your product. Always contact Brave Product Support at 1-800-350-8739 prior to having any service or warranty work performed, as some services performed by parties other than Brave approved service centers may void this warranty. This limited warranty is in lieu of any other warranty expressed or implied, written or oral and Brave assumes no other responsibility or liability outside that expressed within this limited warranty.

**Limited Warranty for Brave Truck Loader Vacs:**

**BRPTL140H      BRPTL160B**

	<b>Consumer Warranty Period</b>	<b>Commercial Warranty Period</b>
<b>Weldments</b>	2 years from date of purchase by user	2 year from date of purchase by user
<b>Wear Parts</b>	In addition to the normal warranty, Brave shall warrant any normal wear items from defects in material or workmanship for a period of 30 days from the date of purchase by user. Normal wear items include, but are not limited to bearings, zerks, impeller, throttle control assembly, hose, handle.	
<b>Engines</b>	The engine warranty is covered under the terms and conditions as outlined by the engine manufactures warranty contained herein and is the sole responsibility of the engine manufacturer. Normal engine maintenance such as spark plugs, oil changes, air filters, adjustments, fuel system cleaning and obstruction due to build up is not covered by this Brave limited warranty.	

“Consumer use” means personal residential household use by a consumer. “Commercial use” means all other uses, including, but not limited to, use for commercial, income producing or rental purposes or when purchased by a business.

This limited warranty applies to the original purchaser of the equipment (verification of purchase, in the form of a receipt, is the responsibility of the buyer), is non-transferable, and covers parts and labor. Parts will be replaced or repaired at no charge, except when the equipment has failed due to lack of proper maintenance. If a part is no longer available, the part may be replaced with a similar part of equal function. Any misuse, abuse, alteration or improper installation or operations will void warranty. Determining whether a part is to be replaced or repaired is the sole decision of Brave. Brave will not provide for replacement of complete products due to defective parts. Any costs incurred due to replacement or repair of items outside of a Brave approved facility is the responsibility of the buyer and not covered under warranty. Transportation costs to and from service center and/or service calls are the responsibility of the customer.

This limited warranty specifically excludes the following; failure of parts due to damage caused by accident, fire, flood, windstorm, acts of God, applications not approved by Brave in writing, corrosion caused by chemicals, use of replacement parts which do not conform to manufacturer’s specifications, damage related to rodent and/or insect infestation and damage caused by vandalism. Additional exclusions: loss of running time, inconvenience, loss of income, or loss of use, including any implied warranty of merchantability of fitness for a specific use. Also, outdoor power equipment needs periodic parts and service to perform well, and this limited warranty does not cover instances when normal use has exhausted the life of a component or the engine.

This limited warranty does not cover any personal injury or damage to surrounding property caused by failure of any part, misuse or inability to use the product. Alteration of the product, including safety features, shall void this limited warranty.

Repair or replacement of parts does not extend the warranty period. This limited warranty gives you specific legal rights. You may also have other rights that vary by state. Please have model number, item number and serial number on hand prior to making a warranty claim or inquiry.

# Warranty Registration Form



## Your Information

Full Name:

\_\_\_\_\_

**Last**

\_\_\_\_\_

**First**

\_\_\_\_\_

**M.I.**

Address:

\_\_\_\_\_

**Street Address**

\_\_\_\_\_

**Apartment/Unit #**

\_\_\_\_\_

**City**

\_\_\_\_\_

**State**

\_\_\_\_\_

**ZIP Code**

Home Phone:

\_\_\_\_\_

Alternate  
Phone:

Email

\_\_\_\_\_

## Purchased From

Company:

\_\_\_\_\_

Address:

\_\_\_\_\_

**Street Address**

\_\_\_\_\_

**Apartment/Unit #**

\_\_\_\_\_

**City**

\_\_\_\_\_

**State**

\_\_\_\_\_

**ZIP Code**

## Model Information

Purchase Date

\_\_\_\_\_

Application Type

**Homeowner**

**Commercial**

**Rental**

\_\_\_\_\_

**Model** (i.e., BRPTL140H)

\_\_\_\_\_

**Serial #**

Signature

\_\_\_\_\_

*Register your product online at [www.braveproducts.com](http://www.braveproducts.com)*



**WARNING:**

Cancer and Reproductive Harm - [www.P65Warnings.ca.gov](http://www.P65Warnings.ca.gov).

**BRAVE**

---

A GNE BRAND

**BRAVE**

*A Brand of:*

*Great Northern Equipment Distributing, Inc.*

*20195 S. Diamond Lake Road, STE 100*

*Rogers, MN 55374*