



Installation Manual

Generator Set

QSJ2.4 Engine with PowerCommand® 1.1 Control

C20 N6 (Spec A), C22 N6 (Spec A)

C25 N6 (Spec A), C30 N6 (Spec A)

C36 N6 (Spec A), C40 N6 (Spec A)

C30 N6H (Spec A), C36 N6H (Spec A)

C40 N6H (Spec A), C45 N6H (Spec A)

C50 N6H (Spec A), C60 N6H (Spec A)

Table of Contents

1. IMPORTANT SAFETY INSTRUCTIONS	1
1.1 Warning, Caution, and Note Styles Used in This Manual	1
1.2 Save These Instructions	1
1.3 General Information	2
1.4 General Precautions	2
1.5 Generator Set Voltage Is Deadly	6
1.6 Fuel and Fumes Are Flammable	6
1.7 Starting Batteries	7
1.8 Batteries Can Explode	7
1.9 Vented Batteries	8
1.10 Moving Parts Can Cause Severe Personal Injury or Death	9
1.11 Exhaust Gases Are Deadly.....	9
1.12 The Hazards of Carbon Monoxide.....	10
2. INTRODUCTION.....	11
2.1 About This Manual.....	11
2.2 Schedule of Abbreviations	11
2.3 Related Literature	13
2.4 Before Installation	14
2.5 Model Specifications	15
3. PRE-INSTALLATION CONSIDERATIONS.....	21
3.2 Installation Codes and Standards for Safety	22
3.3 Required Items for Installation.....	24
4. INSTALLATION.....	29
4.1 Site Assessment and Preparation	29
4.2 Fuel Selection and Fuel System Connection.....	32
4.3 Engine Exhaust.....	43
4.4 Electrical Connections	43
5. STARTUP AND CONFIGURATION.....	57
5.1 Time Setup (1-Phase ATS).....	57
5.2 Exercise Settings	60
5.3 Brightness and Contrast	64
5.4 History and About Menu	66
5.5 InPower Service Tool.....	68
5.6 Installation Checklist	69
5.7 Startup	70
APPENDIX A. FUEL LINE SELECTION.....	73
A.0 Fuel System Pipe Sizing Introduction.....	74
A.1 Gas Pipe Sizing	75

APPENDIX B. OUTLINE AND SYSTEM DRAWINGS.....	87
APPENDIX C. WIRING DIAGRAMS.....	101
APPENDIX D. SEISMIC REQUIREMENTS.....	111
D.1 Seismic Installation Instructions (A044H911).....	113

1 IMPORTANT SAFETY INSTRUCTIONS

SAVE THESE INSTRUCTIONS. This manual contains important instructions that should be followed during installation and maintenance of the generator set and batteries.

Safe and efficient operation can be achieved only if the equipment is properly operated and maintained. Many accidents are caused by failure to follow fundamental rules and precautions.

1.1 Warning, Caution, and Note Styles Used in This Manual

The following safety styles and symbols found throughout this manual indicate potentially hazardous conditions to the operator, service personnel, or equipment.

 DANGER
<i>Indicates a hazardous situation that, if not avoided, will result in death or serious injury.</i>

 WARNING
<i>Indicates a hazardous situation that, if not avoided, could result in death or serious injury.</i>

 CAUTION
<i>Indicates a hazardous situation that, if not avoided, could result in minor or moderate injury.</i>

NOTICE
Indicates information considered important, but not hazard-related (e.g., messages relating to property damage).

1.2 Save These Instructions

This manual contains important instructions for the generator set that should be followed during installation, operation and maintenance of the generator set and batteries.

Thoroughly read the operator manual before operating the generator set. Safe operation and top performance can only be obtained when equipment is properly operated and maintained.

The following symbols in this manual alert you to potential hazards to the operator, service person and equipment.

⚠ DANGER

Alerts you to an immediate hazard that will result in severe personal injury or death.

⚠ WARNING

Alerts you to a hazard or unsafe practice that can result in severe personal injury or death.

⚠ CAUTION

Alerts you to a hazard or unsafe practice that can result in personal injury or equipment damage.

1.3 General Information

This manual should form part of the documentation package supplied by Cummins Inc. with specific generator sets. If this manual has been supplied in isolation, please contact your authorized dealer.

NOTICE

It is in the operator's interest to read and understand all warnings and cautions contained in the documentation relevant to the generator set operation and daily maintenance.

1.4 General Precautions

- Keep multi-type ABC fire extinguishers accessible.
- Make sure that all fasteners are secure and torqued properly.
- Keep the generator set and its compartment clean. Do not store any items in the generator set compartment.
- Before working on the generator set, make sure the generator set is shut down and disabled.
 1. Press the generator set's "O" (Off) button or the red STOP button on the local display (whichever is applicable) to stop the generator set. Allow the generator set to thoroughly cool to the touch.
 2. If applicable, turn off and disconnect the battery charger from the AC source before disconnecting the battery cables.
 3. Disconnect the negative (–) cables from the battery and secure it from contacting the battery terminals to prevent accidental starting.

- Use caution when making adjustments when the generator set is running, hot, or when parts are electrically live, as all situations may cause personal injury or death.
- Used engine oil has been identified by some state and federal agencies as causing cancer or reproductive toxicity. Do not ingest, inhale, or come into contact with used oil or its vapors.
- Do not work on the generator set when mentally or physically fatigued or after consuming alcohol or drugs.

NOTICE

Only trained and authorized personnel shall maintain or service the generator set.

NOTICE

The installation of the generator set shall provide enough ventilation to ensure that gases generated by vented batteries during charging, or caused by equipment malfunction, are removed.

General Safety Precautions

⚠ WARNING

Hot Pressurized Liquid

Contact with hot liquid can cause severe burns.

Do not open the pressure cap while the engine is running. Let the engine cool down before removing the cap. Turn the cap slowly and do not open it fully until the pressure has been relieved.

⚠ WARNING

Moving Parts

Moving parts can cause severe personal injury.

Use extreme caution around moving parts. All guards must be properly fastened to prevent unintended contact.

⚠ WARNING

Toxic Hazard

Used engine oils have been identified by some state and federal agencies to cause cancer or reproductive toxicity.

Do not ingest, breathe the fumes, or contact used oil when checking or changing engine oil. Wear protective gloves and face guard.

⚠ WARNING***Electrical Generating Equipment***

Incorrect operation and maintenance can result in severe personal injury or death.

Do not operate equipment when fatigued, or after consuming any alcohol or drug.

Make sure that only suitably trained and experienced service personnel perform electrical and/or mechanical service.

⚠ WARNING***Toxic Gases***

Substances in exhaust gases have been identified by some state and federal agencies to cause cancer or reproductive toxicity.

Do not breathe in or come into contact with exhaust gases.

⚠ WARNING***High Noise Level***

Generator sets in operation emit noise, which can cause hearing damage.

Wear appropriate ear protection at all times.

⚠ WARNING***Hot Surfaces***

Contact with hot surfaces can cause severe burns.

The unit is to be installed so that the risk of hot surface contact by people is minimized. Wear appropriate PPE when working on hot equipment and avoid contact with hot surfaces.

⚠ WARNING***Toxic Hazard***

Ethylene glycol, used as an engine coolant, is toxic to humans and animals.

Wear appropriate PPE. Clean up coolant spills and dispose of used coolant in accordance with local environmental regulations.

⚠ WARNING***Combustible Liquid***

Ignition of combustible liquids is a fire or explosion hazard which can cause severe burns or death.

Do not store fuel, cleaners, oil, etc., near the generator set. Do not use combustible liquids like ether.

⚠ WARNING**Combustible Gases**

Generator sets in operation have combustible gases under pressure, which if ignited can cause eye and ear damage.

Wear appropriate eye and ear protection at all times.

⚠ WARNING**Combustible Gases**

Generator sets in operation have combustible gases under pressure, which if ignited can cause severe injury.

Do not operate the generator set with any doors open.

⚠ WARNING**Fire Hazard**

Materials drawn into the generator set, as well as accumulated grease and oil, are a fire hazard. Fire can cause severe burns or death.

Keep the generator set and the surrounding area clean and free from obstructions. Make sure the generator set is mounted in a manner to prevent combustible materials from accumulating under the unit.

⚠ WARNING**Automated Machinery**

Accidental or remote starting of the generator set can cause severe personal injury or death.

Isolate all auxiliary supplies and use an insulated wrench to disconnect the starting battery cables (negative [-] first).

NOTICE

Keep multi-type ABC fire extinguishers close by. Class A fires involve ordinary combustible materials such as wood and cloth. Class B fires involve combustible and flammable liquid fuels and gaseous fuels. Class C fires involve live electrical equipment. (Refer to NFPA No. 10 in the applicable region.)

NOTICE

Before performing maintenance and service procedures on enclosed generator sets, make sure the service access doors are secured open.

NOTICE

Stepping on the generator set can cause parts to bend or break, leading to electrical shorts, or to fuel leaks, coolant leaks, or exhaust leaks. Do not step on the generator set when entering or leaving the generator set room.

1.5 Generator Set Voltage Is Deadly

- Generator set output connections must be made by a trained and experienced electrician in accordance with all applicable codes.
- This generator set and the public utility may only be connected to house circuits by means of the automatic transfer switch.

⚠ CAUTION

Improper connections can lead to electrocution of utility workers and damage to equipment. Make sure that the connections are installed properly by a trained technician.

- Use caution when working on live electrical equipment. Remove jewelry, and make sure clothing and shoes are dry. Stand on a dry wooden platform.

1.6 Fuel and Fumes Are Flammable

Fire, explosion, and personal injury or death can result from improper practices.

- DO NOT permit any flame, cigarette, pilot light, spark, arcing equipment, or other ignition source near the generator set or fuel system.
- Fuel lines must be adequately secured and free of leaks. Fuel connection at the engine should be made with an approved flexible line. Do not use copper piping on flexible lines because copper will become brittle if continuously vibrated or repeatedly bent.
- Be sure all fuel supplies have a positive shutoff valve.
- Be sure the battery area has been well-ventilated prior to servicing near it. Lead-acid batteries emit a highly explosive hydrogen gas that can be ignited by arcing, sparking, smoking, etc.

1.7 Starting Batteries

WARNING

Toxic Hazard

The electrolyte in starting batteries is a dilute sulfuric acid that is harmful to the skin and eyes. It is also electrically conductive and corrosive.

Always:

- 1. Wear full eye protection and protective clothing;*
- 2. If the electrolyte contacts the skin, wash it off immediately with water;*
- 3. If the electrolyte contacts the eyes, flush them thoroughly and immediately with water and seek medical attention; and*
- 4. Wash spilled electrolyte down with an acid neutralizing agent. A common practice is to use a solution of one pound (500 grams) bicarbonate of soda (also known as baking soda or sodium bicarbonate) to one gallon (4 liters) of water.*
- 5. Continue to add the bicarbonate of soda solution until the evidence of reaction (that is, foaming) has stopped.*
- 6. Flush the resulting liquid with water and dry the area.*

1.8 Batteries Can Explode

Batteries can explode, causing severe skin and eye burns and can release toxic electrolytes.

WARNING

Combustible Gases

Batteries can explode, causing severe skin and eye burns, and can release toxic electrolytes.

Do not dispose of the battery in a fire, because it is capable of exploding. Do not open or mutilate the battery. Do not charge frozen batteries.

WARNING

Electric Shock Hazard

Batteries present the risk of high short circuit current.

When servicing the generator set:

- Remove watches, rings, or other metal objects.*
- Use tools with insulated handles.*

NOTICE

Servicing of batteries must be performed or supervised by personnel knowledgeable of batteries and the required precautions. Keep unauthorized personnel away from batteries.

- Wear safety glasses.
- Do not smoke.
- Do not charge frozen batteries.
- To prevent arcing when disconnecting the battery:
 1. Press the Off switch from the display and then press the E-Stop button.
 2. Disconnect AC power from any battery chargers.
 3. Remove the negative (-) battery cables to prevent starting.
- To prevent arcing when reconnecting the battery:
 1. Reconnect the positive (+) cables.
 2. Reconnect the negative (-) cables.
 3. Reconnect the battery charger to AC power supply.
- When replacing the generator set battery, always replace it with a battery as specified in this manual.

1.9 Vented Batteries

⚠ WARNING***Toxic Hazard***

The electrolyte in vented batteries is a dilute sulfuric acid that is harmful to the skin and eyes. It is also electrically conductive and corrosive.

Always:

- 1. Wear full eye protection and protective clothing;***
- 2. If the electrolyte contacts the skin, wash it off immediately with water;***
- 3. If the electrolyte contacts the eyes, flush them thoroughly and immediately with water and seek medical attention; and***
- 4. Wash spilled electrolyte down with an acid neutralizing agent. A common practice is to use a solution of one pound (500 grams) bicarbonate of soda (also known as baking soda or sodium bicarbonate) to one gallon (4 liters) of water.***
- 5. Continue to add the bicarbonate of soda solution until the evidence of reaction (that is, foaming) has stopped.***
- 6. Flush the resulting liquid with water and dry the area.***

1.10 Moving Parts Can Cause Severe Personal Injury or Death

- Do not wear loose clothing or jewelry near moving parts, such as cooling fans.
- Keep hands away from moving parts.
- Keep guards in place over fans.

1.11 Exhaust Gases Are Deadly

- Provide an adequate exhaust system to properly expel discharged gases away from enclosed or sheltered areas, and areas where individuals are likely to congregate. Visually and audibly inspect the exhaust system daily for leaks per the maintenance schedule. Make sure that exhaust manifolds are secured and not warped. Do not use exhaust gases to heat a compartment.
- Make sure the unit is well ventilated.

Exhaust Precautions

WARNING

Hot Exhaust Gases

Contact with hot exhaust gases can cause severe burns.

Wear personal protective equipment when working on equipment.

WARNING

Hot Surfaces

Contact with hot surfaces can cause severe burns.

The unit is to be installed so that the risk of hot surface contact by people is minimized. Wear appropriate PPE when working on hot equipment and avoid contact with hot surfaces.

WARNING

Toxic Gases

Inhalation of exhaust gases can cause asphyxiation and death.

Pipe exhaust gas outside and away from windows, doors, or other inlets to buildings. Do not allow exhaust gas to accumulate in habitable areas.

WARNING

Fire Hazard

Contaminated insulation is a fire hazard. Fire can cause severe burns or death.

Remove any contaminated insulation and dispose of it in accordance with local regulations.

The exhaust outlet may be sited at the top or bottom of the generator set. Make sure that the exhaust outlet is not obstructed. Personnel using this equipment must be made aware of the exhaust position. Position the exhaust away from flammable materials - in the case of exhaust outlets at the bottom, make sure that vegetation is removed from the vicinity of the exhaust.

The exhaust pipes may have some insulating covers fitted. If these covers become contaminated they must be replaced before the generator set is run.

To minimize the risk of fire, make sure the following steps are observed:

- Make sure that the engine is allowed to cool thoroughly before performing maintenance or operation tasks.
- Clean the exhaust pipe thoroughly.

1.12 The Hazards of Carbon Monoxide

Carbon monoxide (CO) is an odorless, colorless, tasteless and non-irritating gas. You cannot see it or smell it. Red blood cells, however, have a greater affinity for CO than for oxygen. Therefore, exposure even to low levels of CO for a prolonged period can lead to asphyxiation (lack of oxygen) resulting in death. Mild effects of CO poisoning include eye irritation, dizziness, headaches, fatigue and the inability to think clearly. More extreme symptoms include vomiting, seizures and collapse.

Engine-driven generator sets produce harmful levels of carbon monoxide that can injure or kill you.

Special Risks of CO near the Home

 **WARNING**

Toxic Gases

Carbon monoxide (CO) gas can cause nausea, fainting, or death. Residents can be exposed to lethal levels of CO when the generator set is running. Depending on air temperature and wind, CO can accumulate in or near the home.

To protect yourself and others from the dangers of CO poisoning, it is recommended that reliable, approved, and operable CO detector alarms are installed in proper locations in the home as specified by their manufacturer.

Protecting Yourself from CO Poisoning

- Locate the generator set in an area where there are no windows, doors, or other access points into the home.
- Make sure all CO detectors are installed and working properly.
- Pay attention for signs of CO poisoning.
- Check the exhaust system for corrosion, obstruction, and leaks every time you start the generator set and every eight hours when you run it continuously.

2 Introduction

2.1 About This Manual

⚠ WARNING

Improper installation can result in severe personal injury, death and damage to equipment. The installation must comply with all applicable building codes (including project permits and inspections). The installer should be properly trained and licensed to perform electrical and mechanical equipment installations (including gaseous fuel installation).

NOTICE

Manuals are updated from time to time to reflect changes in the equipment and its specifications. The most up-to-date version of this manual is found on the QuickServe website (<https://quickserve.cummins.com/info/index.html>).

This manual is a guide for the installation of the generator set models listed on the front cover. Proper installation is essential for top performance, reliable operation, and safety. Read through this manual before starting the installation. This manual covers outdoor applications only; for other installations, refer to the *T-030: Liquid-Cooled Generator Set Application* manual available from your Cummins Inc. distributor.

NOTICE

The installation must comply with all applicable building codes.

See the generator set's specific operator manual for operation and maintenance and specific service manual for service.

Refer to the Model Specifications section for specific information about the system and its components.

Refer to the Outline and System Drawings appendix and the Wiring Diagrams appendix for specific information about installation and wiring connections.

2.2 Schedule of Abbreviations

This list is not exhaustive. For example, it does not identify units of measure or acronyms that appear only in parameters, event/fault names, or part/accessory names.

Abbr.	Description	Abbr.	Description
AC	Alternating Current	LED	Light-Emitting Diode
AMP	AMP, Inc. (part of Tyco Electronics)	MFM	Multifunction Monitor
ANSI	American National Standards Institute	Mil Std	Military Standard
ASOV	Automatic Shut Off Valve	MPU	Magnetic Pickup
ASTM	American Society for Testing and Materials (ASTM International)	NC	Normally Closed
ATS	Automatic Transfer Switch	NC	Not Connected
AVR	Automatic Voltage Regulator	NFPA	National Fire Protection Agency
AWG	American Wire Gauge	NO	Normally Open
CAN	Controlled Area Network	NWF	Network Failure
CB	Circuit Breaker	OEM	Original Equipment Manufacturer
CE	Conformité Européenne	OOR	Out Of Range
CCA	Cold Cranking Ampere	OORH/ ORH	Out Of Range High
CFM	Cubic Feet per Minute	OORL/ORL	Out Of Range Low
CGT	Cummins Generator Technologies	PB	Push Button
CMM	Cubic Meters per Minute	PCC	PowerCommand® Control
CT	Current Transformer	PGI	Power Generation Interface
DC	Direct Current	PGN	Parameter Group Number
DEF	Diesel Exhaust Fluid	PI	Proportional/Integral
DPF	Diesel Particulate Filter	PID	Proportional/Integral/ Derivative
EBS	Excitation Boost System	PLC	Programmable Logic Controller
ECM	Engine Control Module	PMG	Permanent Magnet Generator

Abbr.	Description	Abbr.	Description
ECS	Engine Control System	PPE	Personal Protective Equipment
EMI	Electromagnetic Interference	PT	Potential Transformer
EN	European Standard	PTC	Power Transfer Control
EPS	Engine Protection System	PWM	Pulse-Width Modulation
E-Stop	Emergency Stop	RFI	Radio Frequency Interference
FAE	Full Authority Electronic	RH	Relative Humidity
FMI	Failure Mode Identifier	RMS	Remote Monitoring System
FSO	Fuel Shutoff	RMS	Root Mean Square
Genset	Generator Set	RTU	Remote Terminal Unit
GCP	Generator Control Panel	SAE	Society of Automotive Engineers
GND	Ground	scfh	Standard Cubic Feet of gas per Hour
HMI	Human-Machine Interface	SCR	Selective Catalytic Reduction
IC	Integrated Circuit	SPN	Suspect Parameter Number
ISO	International Organization for Standardization	SW_B+	Switched B+
LBNG	Lean-Burn Natural Gas	UL	Underwriters Laboratories
LCD	Liquid Crystal Display	UPS	Uninterruptible Power Supply
LCT	Low Coolant Temperature		

2.3 Related Literature

The literature provided with the generator set is as follows:

- Installation Manual (A045R241)
- Operator Manual (A045R242)

⚠ CAUTION

A generator set must be operated and maintained properly if you are to expect safe and reliable operation. The Operator Manual includes a maintenance schedule and a troubleshooting guide.

The Health and Safety Manual must be read in conjunction with this manual for the safe operation of the generator set:

- ***Health and Safety Manual (0908-0110)***
- ***Warranty Statement (A040H442)***
- ***Emissions Component Defect Warranty Statement (A028X278)***

The relevant manuals appropriate to your generator set are also available. The documents below are in English:

- Service Manual (A045R243)
- Parts Manual (A046Z094)
- EControls, Inc. Service Manual (A035C596)
- Global Control Platform (GCP) Engine Display Interface Software (EDIS) Training Manual (A035C608)
- RA Series Transfer Switch Owner Manual (A046S594) (if applicable)
- PowerCommand® 1302 Controller Owner's Manual (900-0661)
- Standard Repair Times (SRT) Manual (A046Z674)
- Application Manual T-030 - for application information (A040S369)
- Service Tool Manual (A043D529)

2.4 Before Installation

Before beginning the installation of the generator set, verify that the unit was correctly selected. Check the following features:

- Model
- Specifications
- Options
- Fuel Supply
 - The gas supplied to the generator set must be of acceptable quality.
 - The gas supply must have sufficient pressure. Care must be taken to be sure that the gas supply at the generator set, not just at the source, is of proper pressure for operation. The specified pressure must be available while the generator set is starting and running at full load.

- The gas must be supplied to the generator set in sufficient volume to support operation of the generator set. This is normally a matter of selecting fuel line size to be large enough to transport the volume of fuel needed. For liquid propane vapor-withdrawal fuel systems the size and temperature of the fuel tank also affects this requirement.

2.5 Model Specifications

TABLE 1. 2.4L MODEL VARIATIONS

Models	Description
C20 N6, C22 N6, C25 N6, C30 N6, C36 N6, C40 N6	60 Hz, 1800 RPM
C30 N6H, C36 N6H, C40 N6H, C45 N6H, C50 N6H, C60 N6H	60 Hz, 3600 RPM

TABLE 2. COLD WEATHER SPECIFICATIONS (ALL MODELS)

Temperature	Description	Battery Type	Group
Above 4 °C (40 °F)	No starting aids required.	Standard	26
-17 to 4 °C (0 to 40 °F)	Additional coolant heater and battery charger recommended for starting. Factory options available.	Standard	26
Below -17 °C (0 °F)	All starting aides (battery heater, coolant heater, battery charger) recommended. Factory options available.	Larger	34

NOTICE

For NFPA 110 applications, a coolant heater is required. A factory option is available.

TABLE 3. FUEL SPECIFICATIONS 60 HZ, 1800 RPM

	C20 N6	C22 N6	C25 N6	C30 N6	C36 N6	C40 N6
Full Load (Propane)	105.1 scfh 265,000 BTU/hr	112.7 scfh 285,000 BTU/hr	125.4 scfh 315,000 BTU/hr	164.1 scfh 410,000 BTU/hr	182.7 scfh 460,000 BTU/hr	193.6 scfh 490,000 BTU/hr
Full Load (Natural Gas)	259.6 scfh 270,000 BTU/hr	278.8 scfh 290,000 BTU/hr	309.5 scfh 320,000 BTU/hr	380.9 scfh 395,000 BTU/hr	472.3 scfh 490,000 BTU/hr	519 scfh 540,000 BTU/hr
Fuel Pressure	6-13 inches of water column (1.5 - 3.2 kPa) under any condition					

TABLE 4. FUEL SPECIFICATIONS 60 HZ, 3600 RPM

	C30 N6H	C36 N6H	C40 N6H	C45 N6H	C50 N6H	C60 N6H
Full Load (Propane)	195.5 scfh 490,000 BTU/hr	219.6 scfh 550,000 BTU/hr	236.2 scfh 595,000 BTU/hr	256.9 scfh 645,000 BTU/hr	289.5 scfh 725,000 BTU/hr	324.6 scfh 820,000 BTU/hr
Full load (Natural Gas)	476.1 scfh 495,000 BTU/hr	533.3 scfh 555,000 BTU/hr	573.2 scfh 595,000 BTU/hr	623.0 scfh 645,000 BTU/hr	704.7 scfh 730,000 BTU/hr	814.2 scfh 840,000 BTU/hr
Fuel Pressure	6-13 inches of water column (1.5 - 3.2 kPa) under any condition					

TABLE 5. ENGINE SPECIFICATIONS (ALL MODELS)

Specification	Value
Engine	4 cylinder-in-line, SOHC, liquid-cooled, 4-stroke, spark ignited
Displacement	2351 cc (144 in ³)
Spark Plug Gap	1.0 mm (0.040 in) (NA) 0.76 mm (0.030 in) (T/TAA)
Spark Plug Torque	20 Nm (15 ft-lb)
Coolant	50/50 coolant solution (50% pure water and 50% ethylene glycol)
High Crankcase Pressure	No higher than 1.5 kPa
Compression	135 psi (dry test) or higher with less than 15 psi range between cylinders
Oil Capacity	4.3 L (4.54 quarts)
Oil Recommendation	5W30 API SM or newer

TABLE 6. GENERATOR SET SIZE SPECIFICATIONS WITH SOUND LEVEL 1 ENCLOSURE (L X W X H)

kW	RPM	mm	in
20-25	1800	1830 x 864 x 1152	72 x 34 x 45.2
30	3600		
30-40	1800	2384 x 864 x 1152	94 x 34 x 45.2
36-60	3600		

TABLE 7. GENERATOR SET WEIGHT 60 HZ, 1800 RPM

Sound Level 1 (Wet)	C20 N6	C22 N6	C25 N6	C30 N6	C36 N6	C40 N6
kg	503	503	520	580	615	646
lb	1109	1109	1147	1279	1356	1424

TABLE 8. GENERATOR SET WEIGHT 60 HZ, 3600 RPM

Sound Level 1 (Wet)	C30 N6H	C36 N6H	C40 N6H	C45 N6H	C50 N6H	C60 N6H
kg	514	567	635	635	635	648
lb	1134	1249	1399	1399	1399	1429

TABLE 9. ALTERNATOR SPECIFICATIONS 60 HZ, 1800 RPM

	C20 N6	C22 N6	C25 N6	C30 N6	C36 N6	C40 N6
Alternator	Brushless, 4-pole rotating field, single bearing					
Power (kVa):						
1-Phase	20	22	25	30	36	40
3-Phase	25	27.5	31.3	37.5	45	50
Rated Voltages (V):						
1-Phase	120/240					
3-Phase	120/240					
	120/208					
	277/480					
	347/600					

TABLE 10. ALTERNATOR SPECIFICATIONS 60 HZ, 3600 RPM

	C30 N6H	C36 N6H	C40 N6H	C45 N6H	C50 N6H	C60 N6H
Alternator	Brushless, 2-pole rotating field, single bearing					
Power (kVa):						
1-Phase	30	36	40	45	50	60
3-Phase	37.5	45	50	56.3	62.5	75
Rated Voltages (V):						
1-Phase	120/240					

	C30 N6H	C36 N6H	C40 N6H	C45 N6H	C50 N6H	C60 N6H
3-Phase				120/240 120/208 277/480		

<i>NOTICE</i>
Maximum I_2 = 8%.

TABLE 11. GENERATOR SET DERATING GUIDELINES

		Engine Power Available Up To...		Derate At...	
Model	Fuel	Elevation	Ambient Temperature	Elevation	Temperature
C20 N6	NG, LP	1005 m (3300 ft)	40 °C (104 °F)	4% per 305 m (1000 ft)	2% per 10 °C (18 °F) above 40 °C (104 °F)
C22 N6	NG	670.5 m (2200 ft)	40 °C (104 °F)		
C22 N6	LP	1005 m (3300 ft)	40 °C (104 °F)		
C25 N6	NG	0 m (0 ft)	25 °C (77 °F)		
C25 N6	LP	114 m (375 ft)	25 °C (77 °F)		2% per 10 °C (18 °F) above 25 °C (77 °F)
C30 N6	NG	762 m (2500 ft)	40 °C (104 °F)		2% per 10 °C (18 °F) above 40 °C (104 °F)
C30 N6	LP	1005 m (3300 ft)	40 °C (104 °F)		
C36 N6	NG, LP	1005 m (3300 ft)	40 °C (104 °F)		
C40 N6	NG, LP	114 m (375 ft)	40 °C (104 °F)		
C30 N6H	NG, LP	945 m (3100 ft)	40 °C (104 °F)		
C36 N6H	NG, LP	1005 m (3300 ft)	40 °C (104 °F)		
C40 N6H	NG, LP	1005 m (3300 ft)	40 °C (104 °F)		
C45 N6H	LP	1005 m (3300 ft)	40 °C (104 °F)		
C45 N6H	NG, LP	914 m (3000 ft)	40 °C (104 °F)		2% per 10 °C (18 °F) above 25 °C (77 °F)
C50 N6H	NG, LP	114 m (375 ft)	25 °C (77 °F)		
C60 N6H	NG, LP	114 m (375 ft)	40 °C (104 °F)		2% per 10 °C (18 °F) above 40 °C (104 °F)

TABLE 12. CONTROL SPECIFICATION (ALL MODELS)

Specification
Integrated microprocessor based engine, generator, transfer switch control

TABLE 13. DC SYSTEM SPECIFICATIONS (ALL MODELS)

Specification	Value
Nominal Battery Voltage	12 VDC
Battery Group	26 standard, 34 high capacity (a high capacity battery requires an accessory battery tray)
Battery Type	Maintenance free
Minimum Cold Crank Amps	545 standard, 850 high capacity (a high capacity battery requires an accessory battery tray)

3 Pre-Installation Considerations

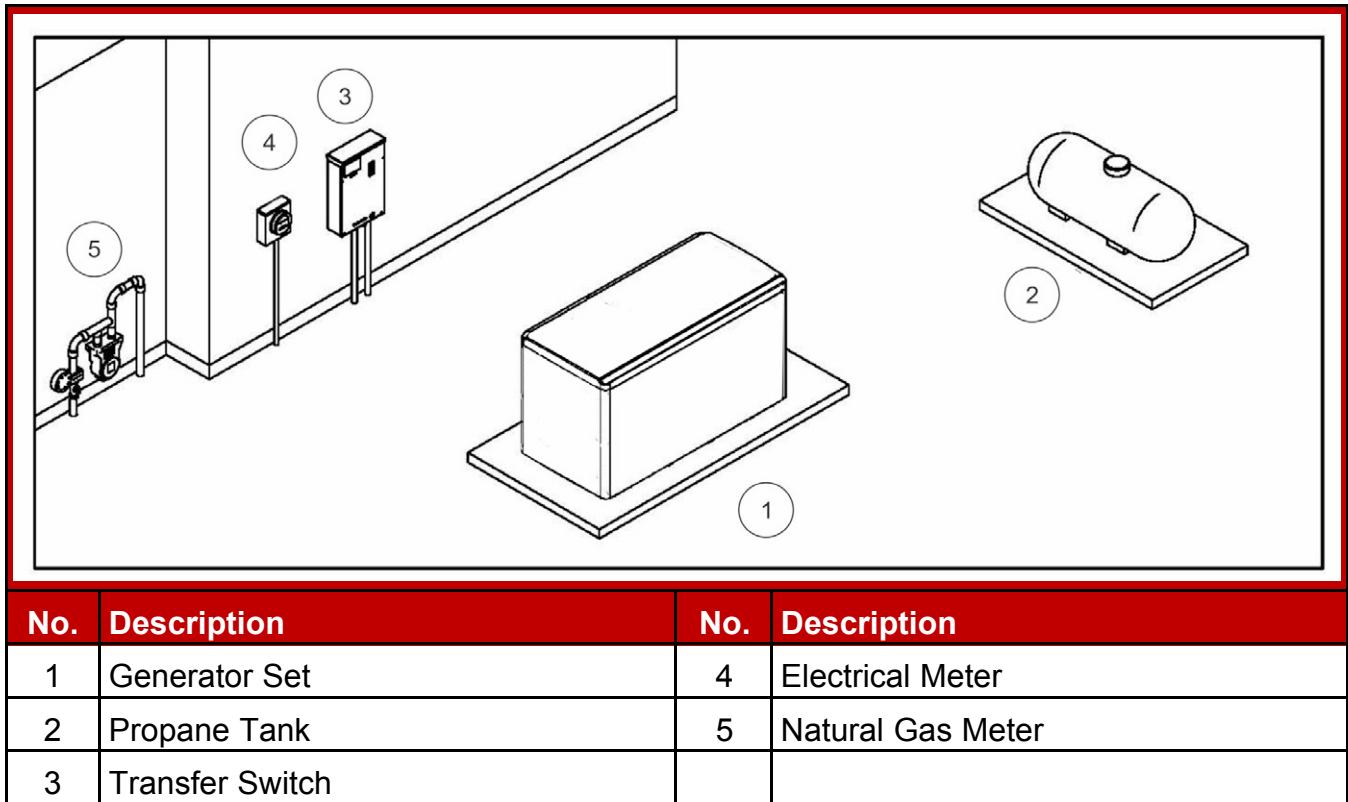

FIGURE 1. SITE PREPARATION EXAMPLE

Areas of consideration:

- Location of the generator set - this is one of the first decisions to be made, as it affects all other aspects of the installation, such as:
 - Length of electric wiring
 - Length of gas lines (natural gas or propane - must be inspected by the gas utility inspectors and building inspectors)
 - Site preparation:
 - Access to the site
 - Trenches
 - Site preparation materials needed
- Fuel supply pressure
- Automatic transfer switch location and connections
- Tools and materials required

- Minimum distance from the propane tank fill (verify the legal minimum distance with local code officials)
- Accessories required (if any) for the customer's application (utility power may be required at the generator set; make plans accordingly)

NOTICE

Depending on the locality and use of the generator set, it may be necessary to obtain an air quality emissions permit before installation begins. Check with local pollution control or air quality authority to determine permit requirements.

3.2 Installation Codes and Standards for Safety

NOTICE

The generator set installer bears sole responsibility for following all applicable local codes and regulations.

The following list of codes and standards may apply to the installation and operation of the generator set. This list is for reference only and not intended to be inclusive of all applicable codes and standards. The address of each agency is listed so that copies of the codes may be obtained for reference. Installation codes and recommendations are subject to change, and may vary by location or over time.

TABLE 14. INSTALLATION CODES AND STANDARDS FOR SAFETY RECOMMENDATIONS

Type	Code or Standard	Title	Organization
US	Code	NFPA 70 - National Electrical Code	National Fire Protection Association 470 Atlantic Avenue Boston, MA 02210
	Code	NFPA 37 - Installation and Use of Stationary Combustion Engines and Gas Turbines	
	Code	NFPA 54 - National Fuel Gas Code	
	Code	NFPA 58 - Storage and Handling of Liquefied Petroleum Gases	
	Code	NFPA 110 - Standard for Emergency and Standby Power Systems	
Canada	Code	CSA Electrical Bulletin	Canadian Standards Association Housing and Construction Materials Section 178 Rexdale Blvd. Rexdale, Ontario, Canada M9Q 1R3
	Code	CSA 22.1 Canadian Electrical Code	
	Code	CSA B149 Installation Code for Gas Burning Appliances and Equipment	
	Standard	CSA C22.2 No. 100 Motors and Generators	
	Standard	CSA C22.2 No. 14 Industrial Control Equipment	
	Code	CSA C282 Emergency Electrical Power Supply for Buildings	
California	Code	California Administrative Code - Title 25 Chapter 3	State of California Documents Section P.O. Box 1015 North Highlands, CA 95660

3.3 Required Items for Installation

Tools and materials are used for the installation of this generator set. These items are identified in the following sections. Please refer to local codes and standards, because they may affect the materials required.

Materials Required

NOTICE

Refer to local codes and standards, which may affect material requirements.

NOTICE

If a 100% rated breaker is used, 90 °C wire must be used for L1, L2, and L3 with the wire size determined by the 75 °C ampacity tables.

NOTICE

A UL-listed grounding electrode terminal within its ratings and suitable for the application must be installed and labeled “Grounding Electrode Terminal”.

Electrical Materials:

NOTICE

Class 1 wiring methods must be used for connecting the generator set.

- Four code compliant AC power wires will be needed: L1, L2, N and Gnd (add another wire for 3-phase for a total of 5 AC wires)
- For RA switches, 4 DC control wires will be needed from the generator to the transfer switch.
- Wire sizes (DC control and power and AC sense only):
 - DC control or AC sense wires under 1000 feet circuit length => 18-14 AWG of the insulation type below
 - DC control or AC sense wires 1000-2000 feet circuit length => 16-14 AWG of the insulation type below
- All AC and DC wires and cables shall be rated 75 °C minimum, stranded copper, and rated for wet locations.
 - For wire sizes 14 AWG and larger, use insulation types including but not limited to: RHW, RHW-2, THHW, THW, THW-2, THWN, THWN-2, XHHW, XHHW-2, USE-2, ZW-2

- For wire sizes 16 and 18 AWG, use insulation types including but not limited to: FFH-2, KFF-2, PAFF, PFF, PGFF, PTFF, RFH-2, RFHH-2, RFHH-3, SFF-2, TFF, TFFN, ZFF
- Code compliant 20 A, 120 VAC, GFCI protected circuit for alternator heaters, battery charger, coolant heater, oil heater, and/or battery heater (if equipped)
- Code compliant conduit for all wires

Mounting Materials:

- Four base tie-down bolts

NOTICE

Seismic zone installations require compliance to specific mounting configurations.

Fuel Materials:

- Flexible fuel line (provided with the generator set, attached to the radiator guard)
- UL listed pipe thread sealant
- Fuel line (natural gas and propane: 6-13 inches of water column [1.5 - 3.2 kPa] fuel pressure) at generator set
- Fuel pressure regulator (as required)
- Manual fuel shut-off at generator set ahead of automatic valves on generator set fuel system

Tools Required

Use appropriate lifting techniques to position the generator set in place.

Transfer Switch Requirements

A transfer switch must be a part of every generator set installation. Transfer switches transfer loads to the generator set during power outages.

NOTICE

Cummins offers a variety of transfer switches, including residential and light commercial options.

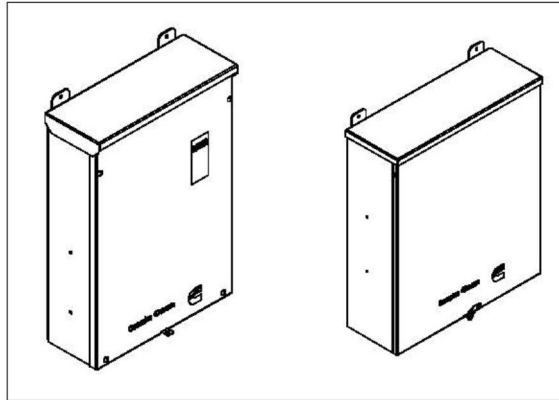

FIGURE 2. CUMMINS TRANSFER SWITCH (RA SERIES)

Before beginning the installation of the transfer switch, verify that the unit was correctly selected. Check the following features:

- Specifications (voltage, amperage, frequency, poles, and phases)
- Enclosure (indoor vs. outdoor)
- Model

Refer to the RA Series Transfer Switch Owner Manual (A046S594) for more detailed information. The RA Series transfer switch is the recommended ATS for use with these generators.

Choosing a Transfer Switch

This section includes block diagrams showing partial or full load coverage for the Cummins RA Series transfer switches. For more information, see the RA Series RA112L1 Automatic Transfer Switch Owner Manual (A052S254) or the RA Series Automatic Transfer Switch Owner Manual (A046S594) (models RA112N3, RA212N3, RA112S3, RA212S3, RA412N3, and RA412S3).

NOTICE

These generator sets can be used with either service entrance transfer switches or non-service entrance transfer switches.

NOTICE

If the load exceeds the generator set rating, it may be necessary to use Cummins' load management kit (A051C329). Cummins' load management kit (A051C329) only applies to air cooled products.

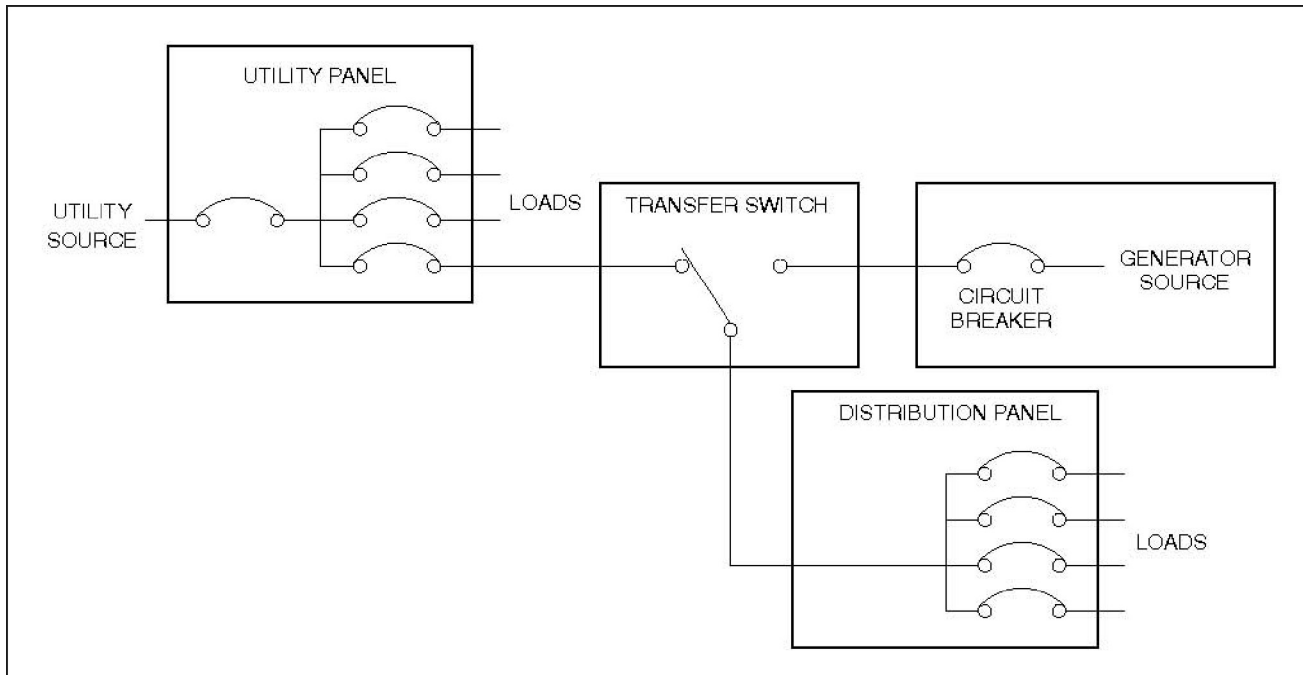

FIGURE 3. TRANSFER SWITCH CONNECTIONS FOR PARTIAL COVERAGE LOAD

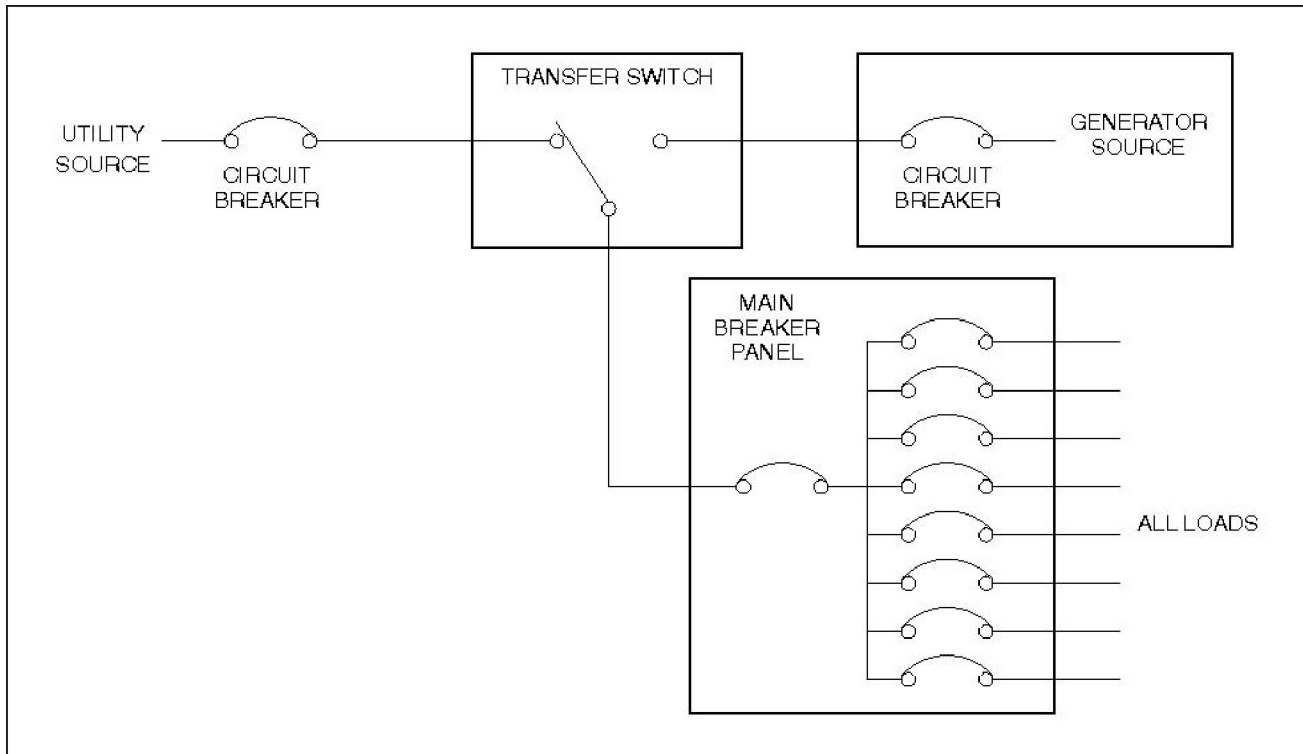

FIGURE 4. TRANSFER SWITCH CONNECTIONS FOR FULL COVERAGE LOAD

Loose Parts Shipped with the Generator Set

The following loose parts are shipped with the generator set:

- Flexible fuel hose assembly (attached to the radiator guard)

- One enclosure key (where applicable)
- Battery tie-down
- Sound level 2 baffle (where applicable)
- Weather enclosure exhaust elbow (where applicable)
- Literature (operator manual, installation manual, health and safety manual, and warranty statements)

4 Installation

4.1 Site Assessment and Preparation

Proper component location and site preparation have a very important impact on completing a successful installation. The major components and sources of power needed for installation include the following items:

- Generator set
- Transfer switch
- Electrical utility
- Fuel source
- Accessories (may be required under certain conditions)

Generator Set Installation Suggestions and Guidelines

- Locate the generator set on stable ground, not subject to flooding. Generator set should not be installed where significant water runoff from a roof or downspouts is present. Sump pump discharge should be routed away from the generator set.
- Locate and orient the generator set such that prevailing winds will carry exhaust gases and fuel leaks away from the house or occupied areas.
- This unit is to be installed so that the risk of contact by people is minimized.

Picking a Location

 **WARNING**

Exhaust gas is deadly. Locate the generator set away from doors, windows, and other openings to the house and where exhaust gases will disperse away from the house.

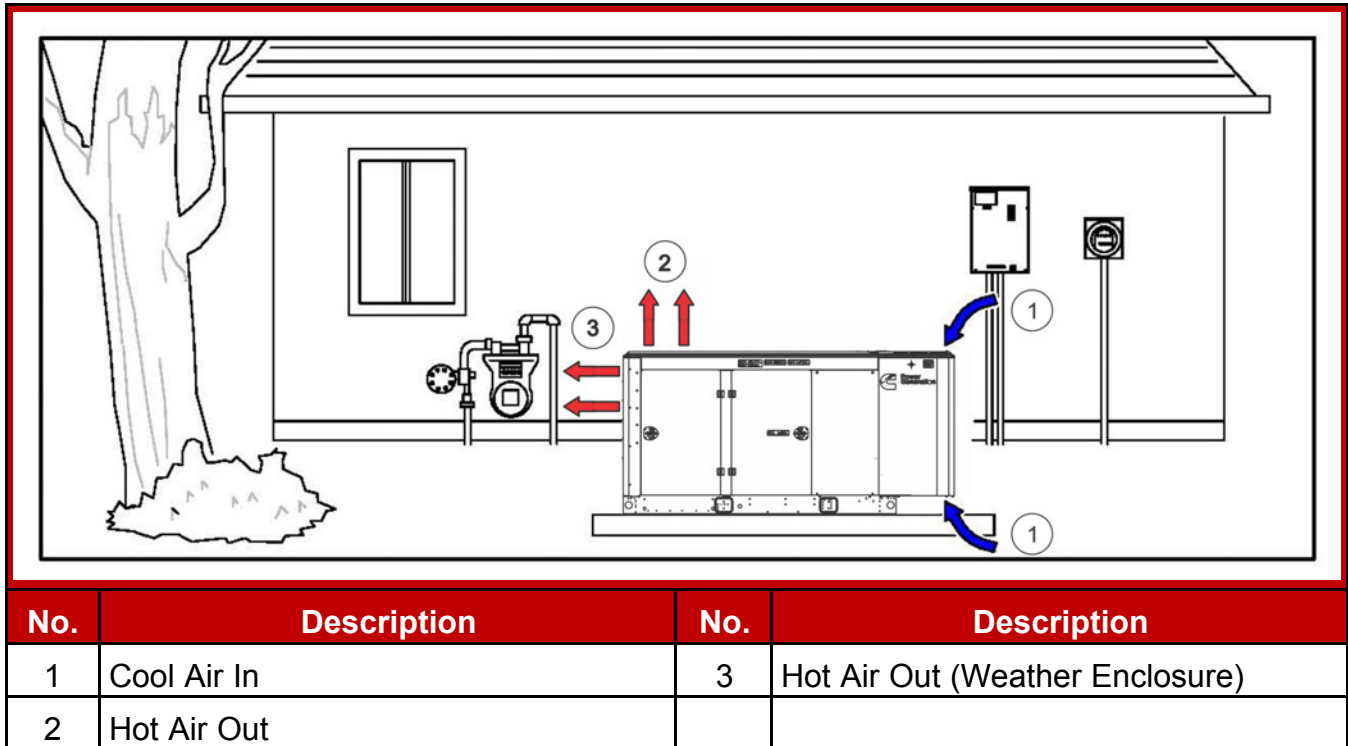

FIGURE 5. EXAMPLE OF GENERATOR SET LOCATION

The generator set location is critical for safety and performance. Follow the guidelines below:

- Must comply with applicable codes (NFPA, NEC, IBC, etc.).
- Use this manual for outdoor installations only. For other applications, contact your local Cummins dealer or refer to the application manual at the following link: <http://www.cumminspower.com/www/literature/applicationmanuals/t030.pdf>
- Consider access to utilities, such as electric/gas meters, transfer switch, remote fuel tank location (for liquid propane if applicable), etc.
- Call the local utilities to mark the locations of buried utility services (gas, electric, or telephone) before digging.
- Verify the locations of any other buried components (gas, electric or telephone) with the homeowner before digging.

Follow the clearance guidelines below:

- The generator set must be located 5 feet from combustible materials (NFPA 37) and any opening in a wall (window, door, vent, etc.).
- The generator set must be located such that the exhaust is not able to accumulate in an occupied area.
- The generator set must have enough room for installation, service, and maintenance.
- The generator set must be located to ensure ventilation openings are not blocked.

- Position the generator set so that cooling air is free to enter and leave the area.
- Locate and position the generator set so that prevailing winds carry exhaust gases and potential fuel leaks away from the house or occupied area.

NOTICE

For all clearance requirements, refer to the Outline and System Drawings section.

Laying the Foundation

When laying the foundation:

1. Clear obstructions, and make sure that there is adequate clearance for access.
2. Level the ground, and make sure that the ground is compact and settled. Ensure that it is stable ground, not subject to flooding.
3. Prepare the concrete pad.
 - The pad should be constructed of reinforced concrete with a 28-day compressive strength of at least 2500 psi (17,237 kPa).
 - The pad dimensions should be the same as those indicated in the Outline and System Drawings appendix.

NOTICE

Seismic installations may require a different pad and securing devices.

NOTICE

Local codes and standards may have different requirements.

4. Lift the generator set onto the pad, and secure it.

Lifting and Moving the Generator Set

⚠ WARNING

Heavy Load

The generator set is heavy. Handle with care.

Dropping the generator set can cause severe personal injury or death. Use appropriate lifting techniques to move the generator set. Keep feet and hands clear when lifting the generator set.

⚠ CAUTION

The generator set is shipped with oil in the engine crankcase. Keep the generator set upright.

Mounting the Generator Set

Mount the generator set on a substantial and level base such as a concrete pad. A non-combustible material must be used for the pad. Verify that the mounting pad is level by length, by width, and diagonally.

NOTICE

Seismic installation may require specific anchorage.

4.2 Fuel Selection and Fuel System Connection

This generator set has a convertible fuel system. The generator may run on natural gas or propane, depending on the preferences of the owner. All generator sets come preconfigured from the factory for natural gas fuel. For more information on converting the fuel system type, see *Converting the Fuel System Type* section.

NOTICE

Fuel systems must be installed by qualified service technicians. Improper installation presents hazards of fire and improper operation, resulting in severe personal injury or property damage.

NOTICE

In some jurisdictions fuel system installations to the generator set must be performed by licensed or registered personnel. Check with the authority having jurisdiction for requirements.

WARNING

Gaseous fuels are flammable, explosive, and can cause severe personal injury or death. Do not smoke if you smell gas, are near fuel tanks for fuel-burning equipment, or are in an area sharing ventilation with such equipment. Keep flames, sparks, pilot lights, electrical arcs, arc-producing equipment and all other sources of ignition well away. Keep a type ABC fire extinguisher handy.

In all fuel system installations, cleanliness is extremely important.

- Make every effort to prevent fuel contamination from:
 - Moisture
 - Dirt
 - Excess thread sealant
 - Contaminants of any kind
- Clean all fuel system components before installing.

Gaseous-fuel supply system design, materials, components, fabrication, assembly, installation, testing, inspection, operation, and maintenance must comply with the applicable codes. See NFPA Standards No. 37, 54, and 58. If this is a seismic installation, refer to IBC codes and standards. Where seismic installation is required, there may be specific anchorage requirements for the generator set and other installed components.

Most codes require a manual shutoff valve ahead of a flexible fuel hose. The generator set includes electric (battery-powered) shutoff valves.

NOTICE

It is recommended that a shutoff valve be located near the generator set for emergency shut off or servicing the generator set. Follow applicable codes.

Until the generator set is connected, cap the fuel line stub-up at the generator set to prevent dirt from entering and gas from discharging if the gas supply shutoff valve is opened accidentally.

To determine the required capacity, refer to the Fuel Line Selection section.

Fuel Line Connections

WARNING

Fuel presents the hazard of fire or explosion that can result in severe personal injury or death. Do not smoke or allow any flame, spark, pilot light or other ignition sources near fuel or in the installation area. Read the important safety precautions in this manual.

1. Refer to the Outline and System Drawings appendix for the location of the fuel supply connection through the side of the generator set.
2. Install a flexible fuel hose, which must be used between the engine's fuel system and fuel supply line to protect the fuel system from damage caused by vibration, expansion and contraction. The fuel hose must be installed according to all applicable codes and standards.

Installing Fuel Lines

The basic components required for fuel line installation are as follows:

- Flexible fuel line (attached to the radiator guard)
- Fuel line
- Shutoff valve
- Fuel supply

To install the fuel lines:

1. Connect a flexible fuel line to the fuel connection ports on the generator set.
2. Connect the opposite end of the flexible fuel line to the fuel source line near the shutoff valve.

NOTICE

A shutoff valve is recommended and often required by local and state codes.

Natural Gas Fuel System

Requirements for a natural gas generator set are as follows:

TABLE 15. NATURAL GAS GENERATOR SET REQUIREMENTS

Component	Description
Gas	Pipeline quality
Fuel Supply	Adequate fuel supply to operate correctly and run at full load
Shutoff Valve	Manual
Fuel Pipe Size	The length of the fuel supply pipe from the gas service entrance to the generator set must be known to determine the correct fuel pipe size. Refer to the charts in the Fuel Line Selection appendix. Iron pipe must be a minimum of Schedule 40 subject to the authority having jurisdiction.
Flexible Fuel Line	Attached to the radiator guard. Protects the fuel system from vibration, expansion, and contraction.

⚠ WARNING

Fuel leaks can lead to explosive accumulations of gas. Prevent gas leaks and the accumulation of gaseous fuel in the event of a leak.

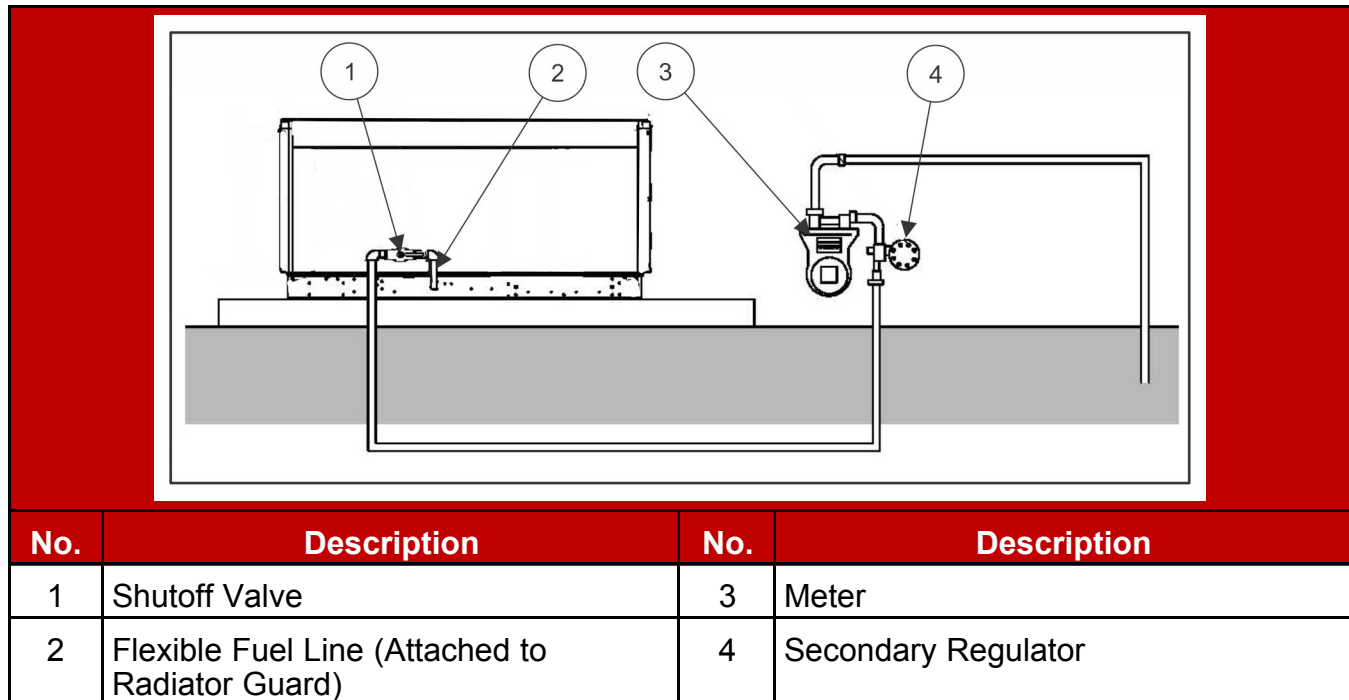

FIGURE 6. TYPICAL NATURAL GAS INSTALLATION

Natural Gas Supply Line Size

The natural gas supply meter may need to be exchanged for a higher capacity meter to supply the additional gas consumed by the generator set.

Use the total load requirement of the generator set to determine the size of the fuel supply pipe. Use the tables and charts in the Fuel Line Selection appendix to determine the correct pipe size.

An older site might require upgrading and repair of the gas supply system. Schedule an upgrade or repair to minimize power and gas supply interruptions.

Make sure the full load fuel supply pressure at the inlet to the generator fuel shutoff valves matches the requirements in the Model Specifications section.

Propane Fuel System

Propane vapor can be used as a primary fuel source or as a backup fuel source for the generator sets with two independent fuel sources connected to the generator set.

⚠ WARNING

Fuel leaks can lead to explosive accumulations of gas. Propane sinks in air and can accumulate inside housings, basements, and other below-grade spaces. Prevent gas leaks and the accumulation of gaseous fuel in the event of a leak.

NOTICE

NFPA Standard No. 58 requires all persons handling and operating propane to be trained in proper handling and operating procedures.

The required components in a propane vapor fuel system are as follows:

Component	Description
Propane Tank	Make sure to identify and use the correct tank size based on fuel flow requirements and the lowest average temperature for your region. If the tank is sized incorrectly, the generator set could run out of fuel. Refer to the Fuel Line Selection appendix.
Shutoff Valve	Useful during installation or in the event of a leak (may be required to meet local codes).
Primary Regulator	Located at the tank outlet, the primary regulator reduces the tank pressure to the working pressure in the fuel supply line. Primary and secondary regulators must be properly matched for a safe and functional system. Consult with your propane supplier to ensure that the regulators are properly sized.
Secondary Regulator	Located near the generator set, the secondary regulator reduces the higher line pressure to a working pressure that matches the requirements in the Model Specifications section. Higher pressure before the secondary regulator is necessary to ensure that there is enough fuel available at the secondary regulator for a fully loaded generator set.
Fuel Line	Connects to the fuel supply. It must be sized properly using the propane fuel line sizing charts (refer to the Fuel Line Selection appendix). Installation must comply with all national, state, and local codes.
Cummins Flexible Fuel Line	Attached to radiator guard. Protects the fuel system from vibration, expansion, and contraction.

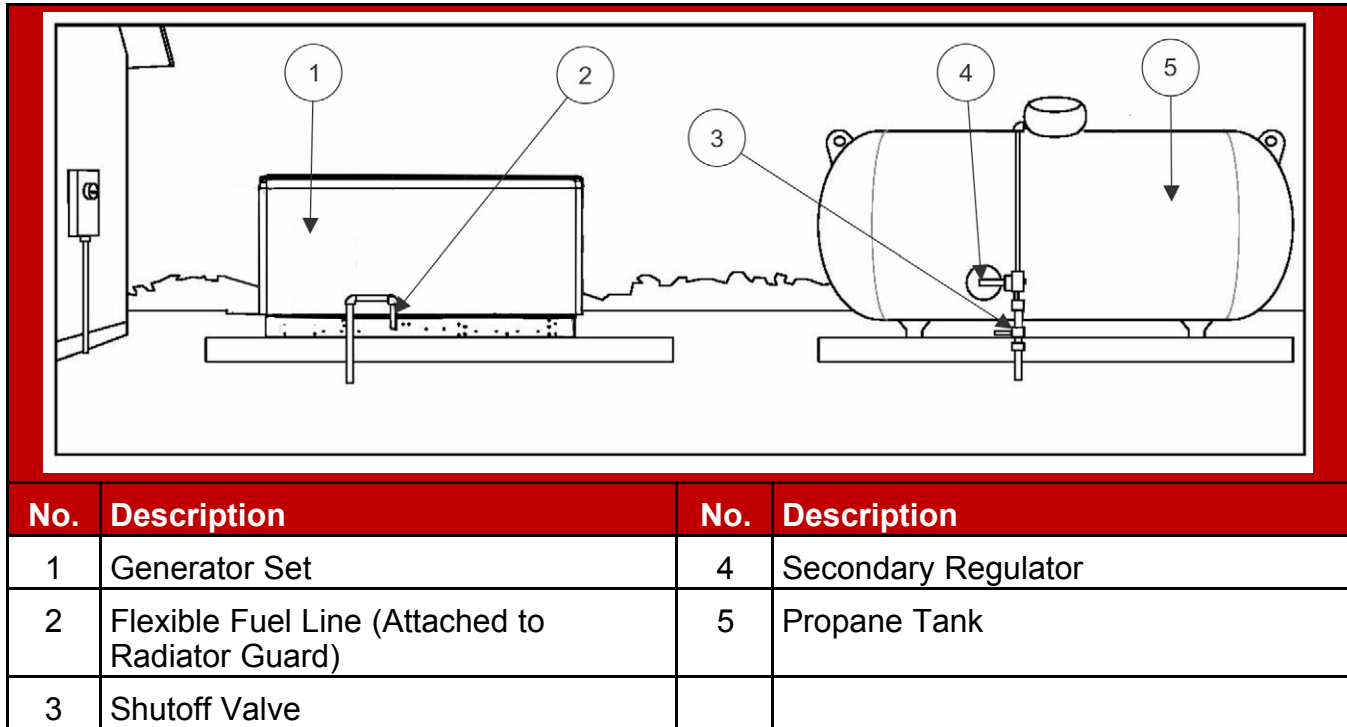

FIGURE 7. TYPICAL PROPANE INSTALLATION

Propane Fuel Requirements

⚠ WARNING

Propane presents the hazard of fire or explosion that can cause severe personal injury or death. Do not permit any flame, spark, arc-producing equipment, switch, pilot light, cigarette, or other ignition source near the fuel system. Keep an ABC type fire extinguisher nearby.

⚠ WARNING

Fuel leaks can lead to explosive accumulations of gas. Propane sinks in air and can accumulate inside housings, basements and other below-grade spaces. Prevent gas leaks and the accumulation of gaseous fuel in the event of a leak.

Use clean, fresh HD-5 grade propane or equivalent product consisting of at least 90% propane.

NOTICE

NFPA Standard No. 58 requires all persons handling and operating propane to be trained in proper handling and operating procedures.

NOTICE

Commercial propane may contain more than 2.5% butane, which can result in poor fuel vaporization and low tank pressure, resulting in poor engine starting and operation in below 32 °F (0 °C) temperatures.

Propane Tank Size

When propane is used, size the tank correctly to ensure successful generator set operation.

Considerations when figuring the proper propane tank size:

- Temperature is a critical factor that affects the size of the tank.
 - Ambient temperatures can affect how quickly liquid is converted to gas.
 - Generator set fuel consumption is the same regardless of the surrounding temperatures.
 - Colder weather climates require larger fuel tanks. Larger tanks have greater surface area, allowing more liquid propane to vaporize and maintain the required fuel rate.
 - Propane is stored as liquid. Keep the fuel tank at least 50% full to operate properly. Fuel tanks that are less than 50% full may not have the capacity to vaporize enough propane to operate the generator set and other LP appliances.
- Propane tanks are sized by their internal volume in gallons, not the amount of fuel they can hold (which is less).
- Propane tanks are generally filled to only 80% of their capacity. Therefore, a 500-gallon (1892 L) tank results in 400-gallon (1514 L) tank capacity.
- Low ambient temperatures affect the amount of fuel available from the propane tank.
- Approximately 60% of the fuel (in gallons) filled in the tank can be effectively used. Therefore, a 500-gallon (1892 L) tank results in 240-gallon (908 L) usable capacity.

To assist in the proper installation of the propane tank, follow the guidelines below.

- Consult your tank and propane supplier for assistance in all aspects of determining tank size, selection of components and installation requirements.
- Fit the propane tanks with a pressure reducing regulator before connection to the generator set to prevent fuel system damage.
- Locate the propane tanks and all other fuel system components at least 10 feet (3 meters) from any source of combustion (including the generator set). The fuel supplier or local code may require a larger distance between the tank and source of combustion.

- Install the propane tanks according to all national and local codes and standards, and as required by the fuel tank and fuel supplier.

Refer to the [Fuel Line Selection](#) appendix for propane figures and tables.

Propane Vapor Fuel Supply Line Size and Pressure

Fuel line size depends on the amount of fuel needed to run the generator set at full load at the distance the fuel must be moved.

To correctly size the fuel pipe, you must also take other loads operated from the fuel supply line into consideration, such as space heating and water heating equipment.

Use the total fuel requirement of the generator set and other connected appliances to determine the size of the fuel supply pipe. Use the tables and charts in the Fuel Line Selection appendix to determine the correct pipe size.

See the Model Specifications section for fuel system specifications, including fuel consumption and required fuel system pressure at the generator set.

See the Propane Fuel System section for a typical propane vapor installation.

See the Fuel Line Selection appendix for fuel capacity at given distances and pipe size.

NOTICE

Make sure the fuel supply pressure at the inlet of the generator set fuel regulator (at service port) matches the requirements in the Model Specifications section.

Converting the Fuel System Type

For single-fuel systems, the generator set leaves the factory configured for natural gas. No mechanical parts are required for fuel conversion. To convert the fuel system type, configure the control.

1. Enter the Fuel System Menu.
 - a. From any Info Menu, hold down the up and down arrows simultaneously for two seconds. The Service Menu appears.
 - b. Select **Setup Menus**.
 - c. Enter the password **574** on the Password screen. The Setup Menu appears.
 - d. Select **Genset Service**.
 - e. Select **Genset**.
 - f. Advance through the screens until the Fuel System Setup Menu appears.
2. Update the Fuel System Type on the Fuel System Setup Menu. See the figure below.
 - a. Press **Adjust** on the Fuel System Menu.

b. Edit the Fuel System using the horizontal arrow key. Change the field value by using the +/- keys.

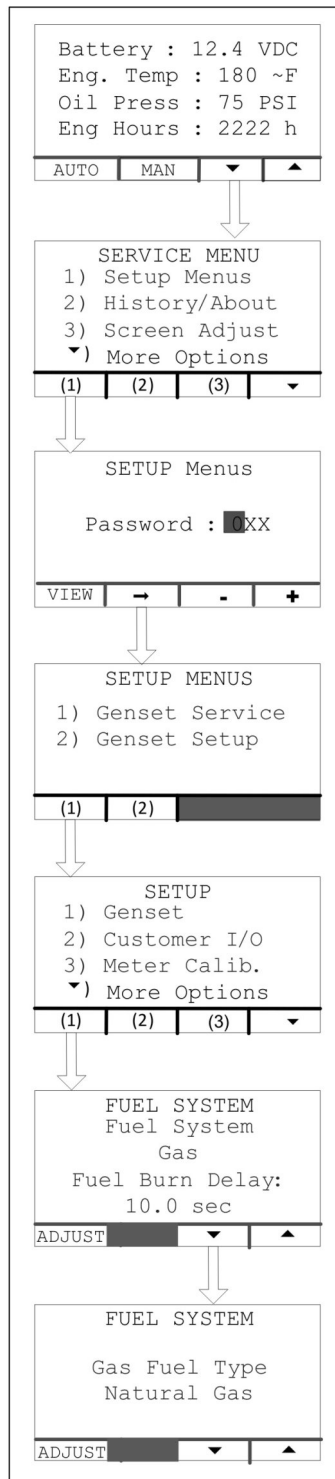

FIGURE 8. FUEL SYSTEM TYPE

3. Update the Gas Fuel Type on the Fuel System Menu.
 - a. When changing the Fuel System, a second Fuel System Menu is enabled. Advance to this menu by pressing the down arrow after saving any changes.
 - b. Press **Adjust** on the Fuel System Menu.
 - c. Edit the Gas Fuel Type by using the horizontal arrow key. See the figure below.

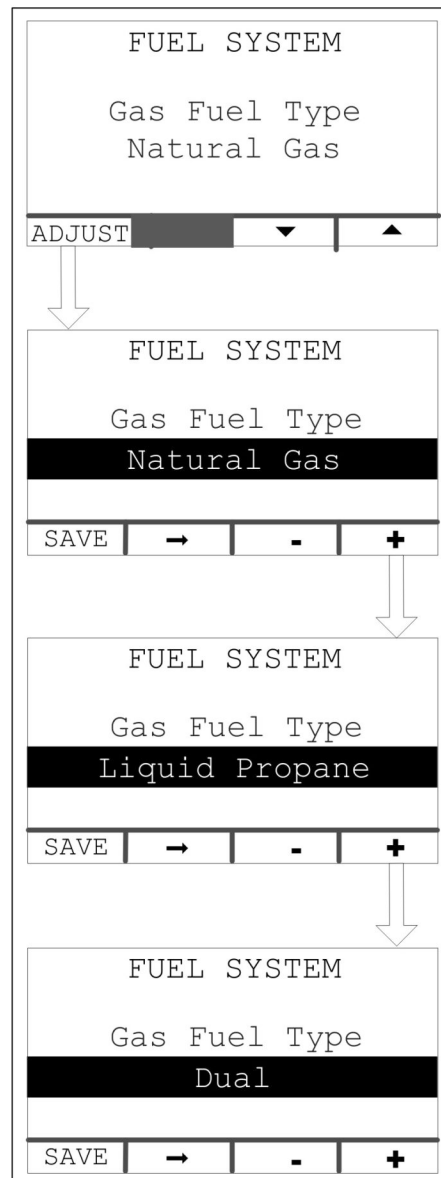

FIGURE 9. GAS FUEL TYPE

- d. Change the field value to Natural Gas, Liquid Propane, or Dual by using the +/- keys.
- e. Select **Save** to save the changes.

Testing the Fuel System for Leaks

After assembly and before initial operation, all of the fuel system components must be tested and proven free of any leaks.

WARNING

Fuel presents the hazard of explosion or fire which can result in severe personal injury or death. Do not use an open flame to check for leaks. Do not smoke or allow any flame, spark, pilot light, arc-producing equipment, switch or other ignition sources around fuel or fuel components. Keep multi-type ABC fire extinguishers close by.

NOTICE

Follow any local codes and standards, as they may require a different method or documentation of a leak test.

Perform the following fuel piping system leak check:

1. After assembly and before initial operation of generator set, test all fuel system components as required per the National Fuel Gas Code (NFPA 54).
2. The National Fuel Gas Code requires that the generator set be isolated from the *piping* system by disconnecting it and capping the outlet prior to test. The test pressure required is the greater of 1.5 times the supply pressure or 3 psi (20.7 kPa) minimum.
3. After successfully completing the previous step, connect the generator set to the fuel piping system.
4. To verify that all connections from the fuel piping system to the generator set are free of leaks, conduct a bubble test using an approved leak detection solution (or equivalent method) with the system pressure of 0.8 to 1.0 psi (5.5 to 7.0 kPa).
5. Spray the bubble solution on all of the joints.
6. Inspect all of the joints and monitor the line pressure. If bubbles appear, there is a leak.
7. If any leaks are found, repair the joint or replace components as needed.
8. Verify the leak has been fixed.

NOTICE

The leak detection solution (that is, bubble solution) must be non-corrosive and be free of ammonia and chlorine.

4.3 Engine Exhaust

The exhaust system for this generator set is complete and was designed specifically for this generator set. Do not modify or add to the exhaust system of this generator set.

WARNING

Exhaust gas is deadly. Make sure that the exhaust system terminates away from building vents, windows, doors, and sheltered spaces that may not have ample fresh air ventilation.

WARNING

Engine discharge air and exhaust carry carbon monoxide gas (odorless and invisible) which can cause asphyxiation and death. Never use engine discharge air or exhaust for heating a room or enclosed space.

4.4 Electrical Connections

WARNING

Improper installation can lead to electrocution and damage to property. Electrical connections must be made by a licensed electrician.

WARNING

Automatic startup of the generator set during installation can cause severe personal injury or death. Make sure the generator set is shut down and disabled:

- 1. Press the generator set's "O" (Off) button to stop the generator set. Allow the generator set to thoroughly cool to the touch.***
- 2. Turn off and disconnect the battery charger from the AC source before disconnecting the battery cables.***
- 3. Disconnect the negative (-) cable from the battery and secure it from contacting the battery terminals to prevent accidental starting.***

NOTICE

Refer to regional codes and the National Electrical Code (NFPA 70) for all electrical installation requirements.

NOTICE

Class 1 wiring methods must be used for connecting the generator set.

Electrical Preparations

1. Run all wires through a single conduit (unless prohibited by the authority having jurisdiction).

NOTICE

Be sure to account for any needed accessories, such as a remote display, etc.

2. Connect the conduit to the generator set. Refer to the specific outline drawing in the Outline and System Drawings section for the size and location of the hole provided for electrical conduit connection. The existing hole may be increased in size to match conduit used.

AC Connections

WARNING

Automated Machinery

Accidental or remote starting of the generator set can cause severe personal injury or death.

Isolate all auxiliary supplies and use an insulated wrench to disconnect the starting battery cables, negative (-) cable first.

NOTICE

If a 100% rated breaker is used, 90 °C wire must be used for L1, L2, and L3 with the wire size determined by the 75 °C ampacity tables.

NOTICE

When using a circuit breaker with an adjustable, electronic trip unit, the amperage and trip curve settings may need adjustment to match the generator set load wiring, or downstream loads and circuit breakers. An accessory seal kit (part number A026M166) is available to tamper-proof the adjustable settings.

1. Make sure the generator set is shut down and disabled:
 - a. Press the Off switch from the display and then press the E-Stop button to stop the generator set. Allow the generator set to thoroughly cool to the touch.
 - b. Turn off and disconnect the battery charger from the AC source before disconnecting the battery cables.
 - c. Disconnect the negative (-) cable from the battery and secure it from contacting the battery terminals to prevent accidental starting.
2. Remove the enclosure side panel to access the main circuit breaker box.
3. Place the circuit breaker handle in the OFF position.

4. Remove the four bolts holding the circuit breaker cover.
5. Connect the conductors to the circuit breaker load-side terminals, neutral lug, and equipment grounding lug. For grounding and neutral connections, look for the symbols on the generator set circuit breaker box (shown below, and in the next image at the bottom).

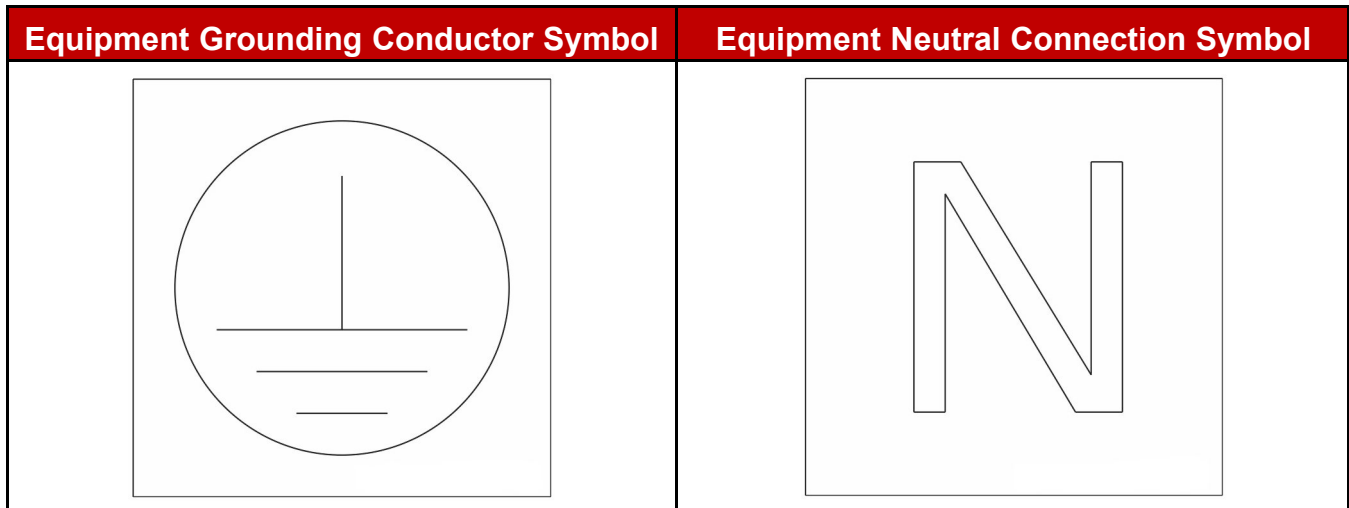

FIGURE 10. SYMBOLS ON CIRCUIT BREAKER BOX

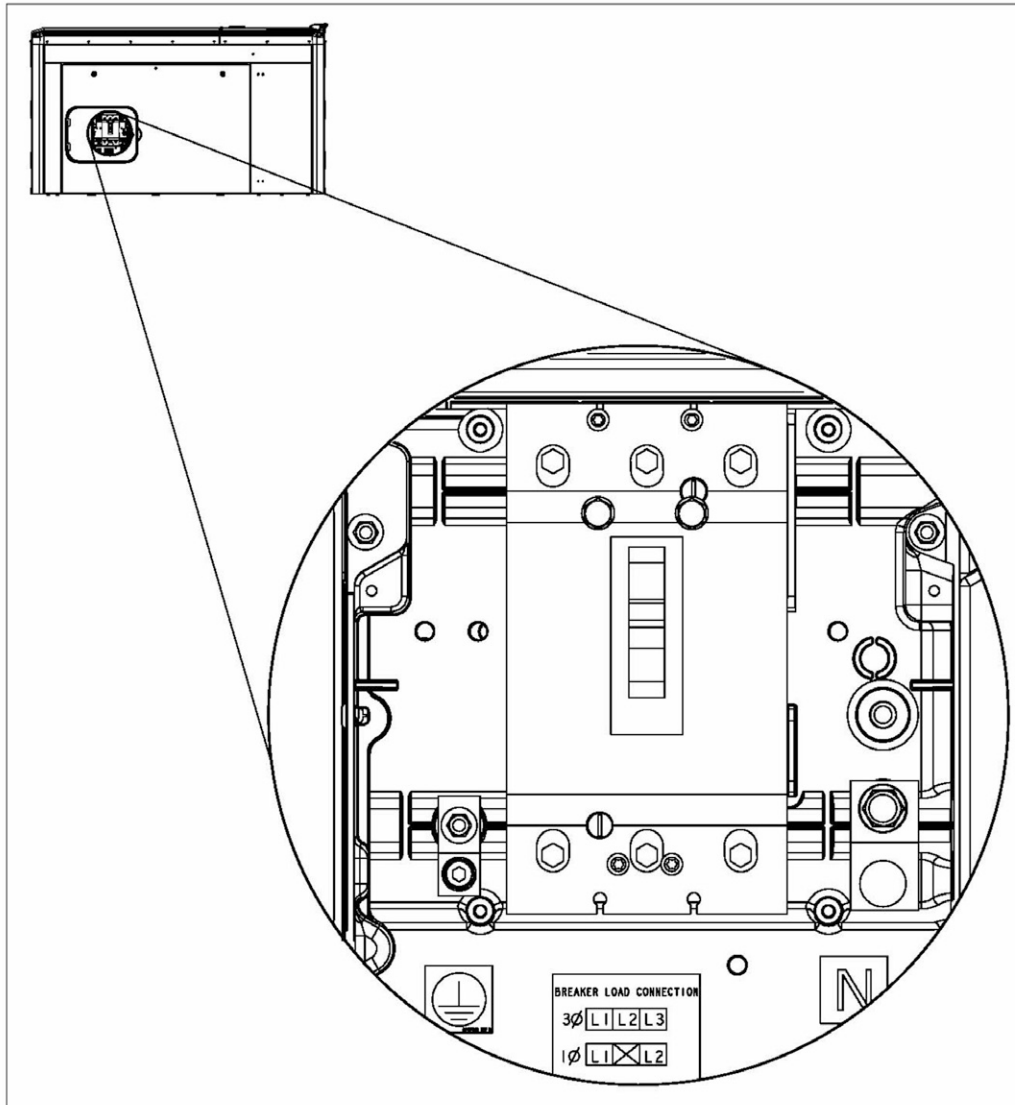

FIGURE 11. CIRCUIT BREAKER AC LOAD CONNECTIONS LOCATION (SYMBOLS SHOWN AT BOTTOM)

6. Torque the circuit breaker terminals per specifications on the circuit breaker label.
7. Torque the neutral lug to 31.1 Nm (275 in-lb).
8. Torque the equipment grounding lug to 13.8 Nm (120 in-lb).
9. Fill in the stub-up openings with an approved duct seal or mastic tape to keep out insects and rodents.
10. Install the circuit breaker cover.

Automatic Transfer Switch AC Connections

⚠ WARNING

Failure to use an approved transfer switch can lead to the electrocution of personnel working on the utility lines, damage to equipment, fire, or personal injury. An approved switching device must be used to prevent interconnection to the public utility.

Install the transfer switch in accordance with the appropriate RA Series Transfer Switch Owner Manual.

Factory Option and Accessory Connections

NOTICE

Use copper conductors only.

AC powered options or accessories available:

- Battery charger
- Engine coolant heater
- Alternator heater
- Battery warmer
- CCV heater

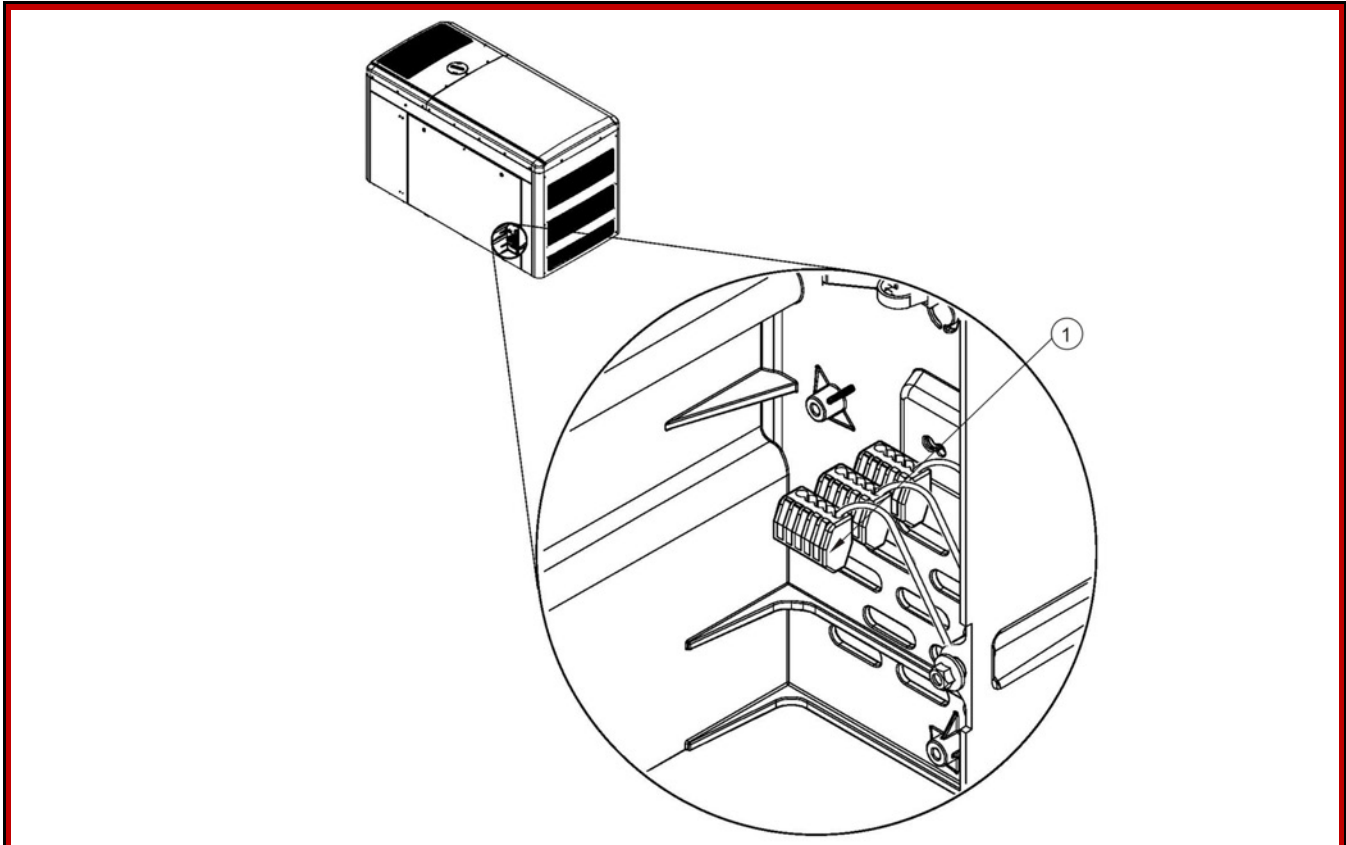

No.	Description	No.	Description
1	AC Distribution Connector(s)		

FIGURE 12. AC ACCESSORY CONNECTIONS

The battery charger, engine coolant heater, alternator heater, CCV heater, and battery warmer require power from a 120 VAC, 20 Amp protected circuit from the Main Distribution Panel. Use 12 AWG 75 °C (167 °F) conductors to make connection to the generator set AC distribution connector.

DC Connections

NOTICE

When selecting and installing conduit to the generator set, account for any needed accessories, such as a remote display, etc.

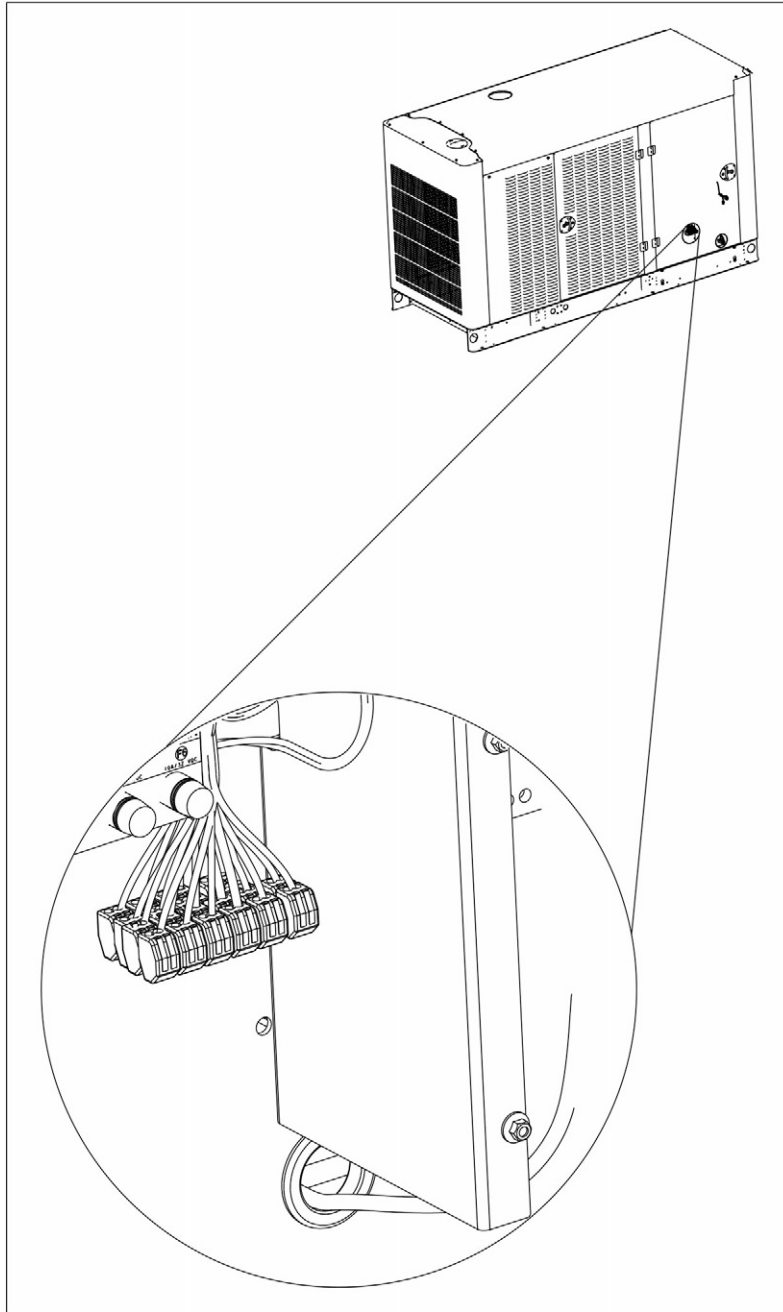

FIGURE 13. DC CUSTOMER CONNECTIONS
Automatic Transfer Switch DC Connections

⚠ WARNING

Failure to use an approved transfer switch can lead to the electrocution of personnel working on the utility lines, damage to equipment, fire, or personal injury. An approved switching device must be used to prevent interconnection to the public utility.

Install the transfer switch in accordance with the appropriate RA Series Transfer Switch Owner Manual.

The following image is an example that shows the location of the connectors in the generator set where the ATS DC control wires terminate. This is also the location of the connectors where load management control wires (if applicable) terminate.

NOTICE

Load management is only available with air cooled product.

Refer to the Wiring Diagrams appendix for generator set to RA transfer switch DC customer connections.

NOTICE

Class 1 wiring methods should be used for connecting the generator set and transfer switch signal wiring.

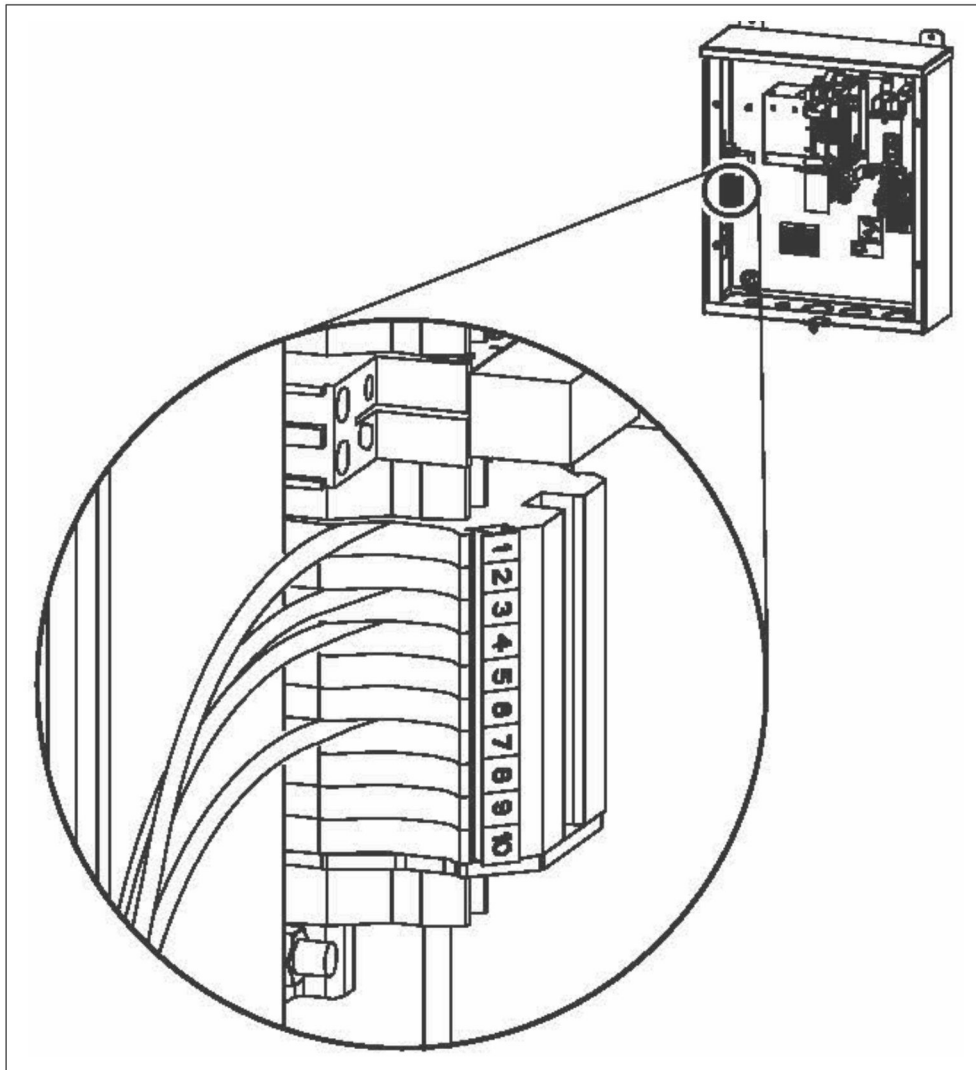

FIGURE 14. EXAMPLE OF RA SERIES TRANSFER SWITCH DC CONNECTIONS LOCATION

Drilling Locations for Electrical Connections

Preferred routing of electrical leads is vertically through conduit that is installed in the mounting pad that terminates in the electrical connection areas.

- Refer to the generator set foundation outline drawing in the Outline and System Drawings appendix for location of electrical connection areas.
- In some cases, it may be necessary to route electrical leads horizontally in conduits that pass through the generator set chassis.
- Refer to the figure below for available drilling space for conduit holes in the side of the chassis. Holes up to 7.6 cm (3 in) in diameter can be made in the chassis in the areas shown. Exceeding 7.6 cm (3 in) in diameter may cause failure of the chassis.

- Comply with NEC and local codes and standards for installation of wires for electrical circuits. Refer to NEC standards for required wire bend radius and ampacity of load leads.

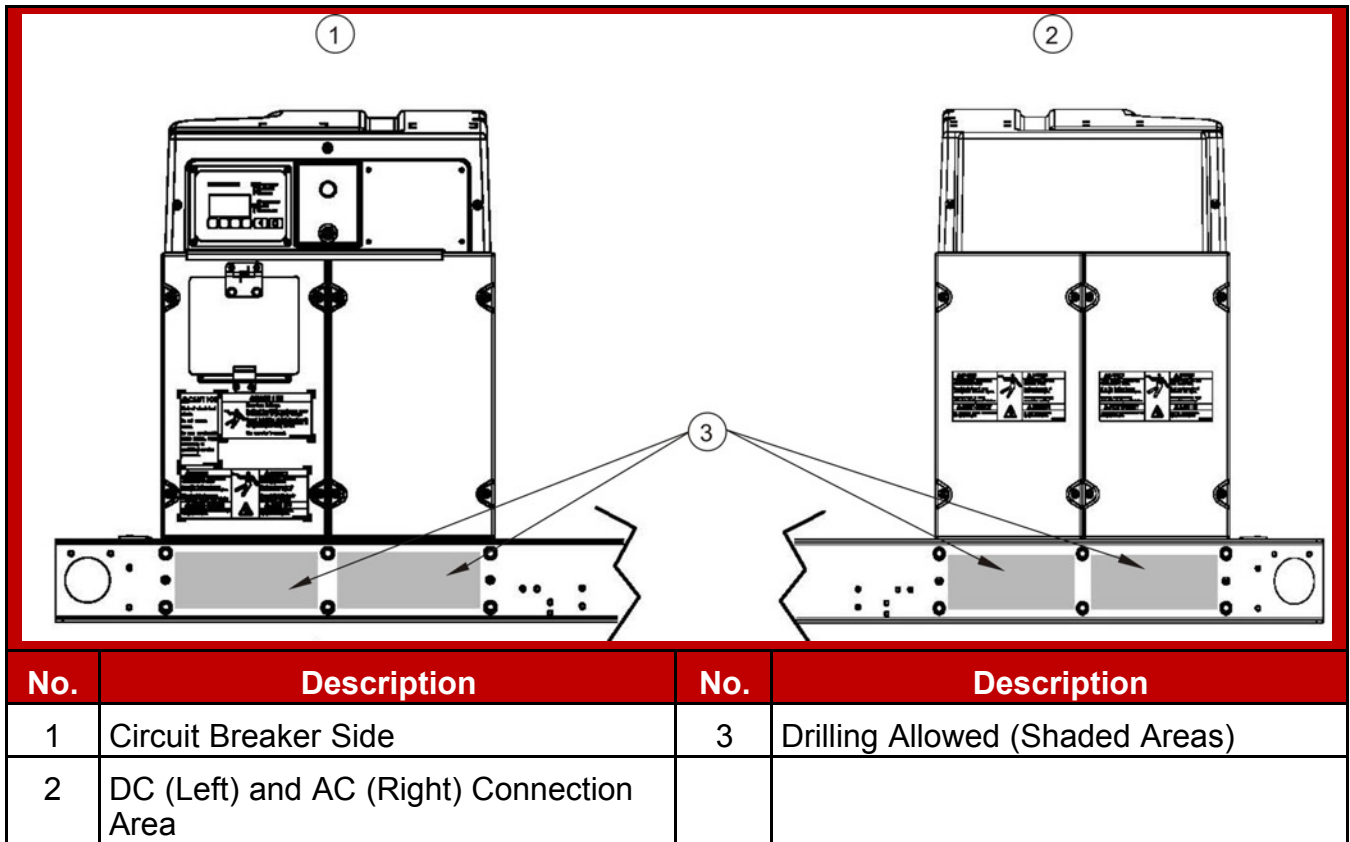

FIGURE 15. DRILLING LOCATIONS FOR SIDE ELECTRICAL CONNECTIONS

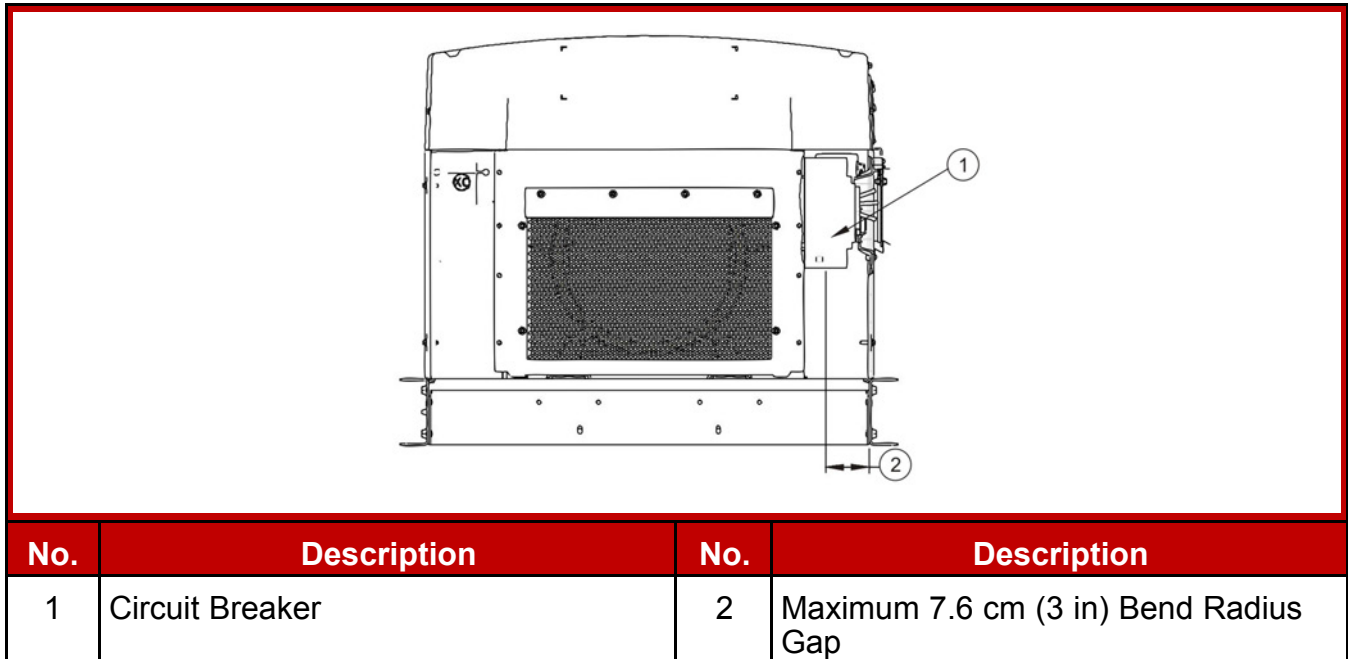

FIGURE 16. CABLING ROOM FOR CIRCUIT BREAKER

Grounding

NOTICE

The generator set is shipped from the factory with the neutral and equipment ground not bonded together.

Refer to local codes and standards for grounding procedures.

Battery

The generator set requires a 12V battery (negatively grounded) for engine cranking and powering the electronic control system. When the generator set is running, the battery is charged from the engine-driven battery alternator. When the set is not running, an AC powered battery charger is needed to keep the battery charged.

As part of the installation, make sure that the battery is secured to the battery tray with the strap provided.

To connect the battery:

1. Connect the positive battery terminal.
2. Connect the negative battery terminal.
3. Make sure that the black and red battery cable boots are in place.

Refer to the Model Specifications section for battery specifications.

An optional thermostatically controlled battery heater is available for more reliable starting in ambient temperatures down to -40 °F (-40 °C).

To prevent injury due to accidental startup:

- Do not connect the battery cables to the battery until the installation has been completed;
- Make sure tools, rags, and body parts are kept away from any rotating parts or electrically live parts; and
- Make sure it is time to start the generator set.

NOTICE

Ensure that the AC power to the battery charger is disconnected when installing the battery.

NOTICE

Wear proper safety protection when working around batteries. Keep open flames and sparks away from the equipment.

NOTICE

Only personnel knowledgeable of batteries and required precautions should perform or supervise battery servicing.

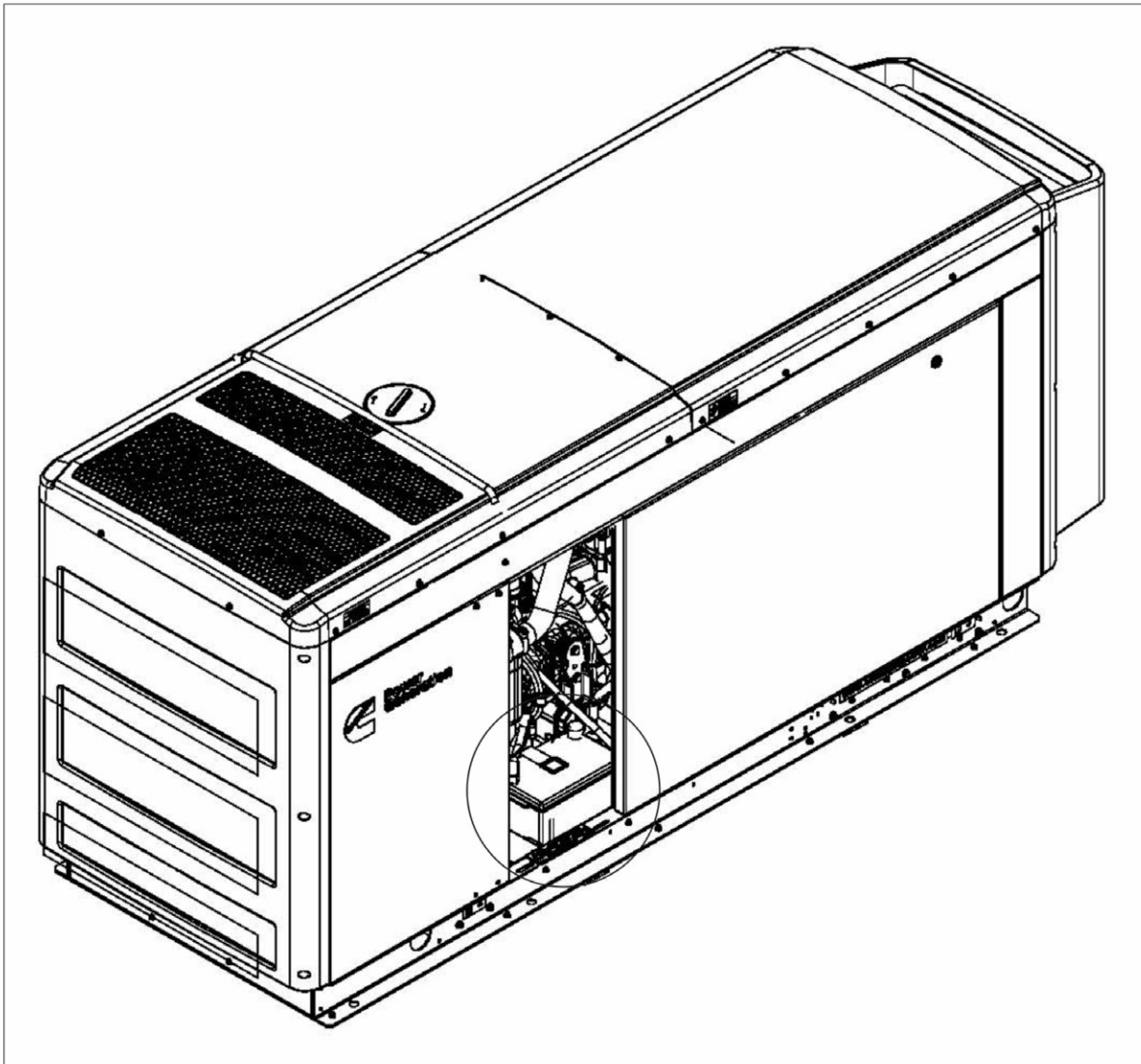

FIGURE 17. BATTERY LOCATION

This page is intentionally blank.

5 Startup and Configuration

5.1 Time Setup (1-Phase ATS)

NOTICE
When battery power is lost, these settings must be reset.

NOTICE
Not applicable without a single phase RA series transfer switch.

To set up the generator set clock for the current date and time:

1. From any Information Menu, hold down the up and down arrows simultaneously for two seconds. The Service Menu appears.
2. Access the Time Setup screen by selecting **Clock Exerciser** on the Genset Service Menu.
3. Select **Adjust**.

When updating these settings, the functions of the keys are as follows:

- The horizontal right arrow key is used to select successive blocks for editing settings on the screen.
- Select the left arrow to return to the previous screen.
- Adjust values by using the + or - keys on the Adjust Menu of the Time Setup screen.
- Press **Save** to save any changes. After saving, the Save button changes to the Adjust button.

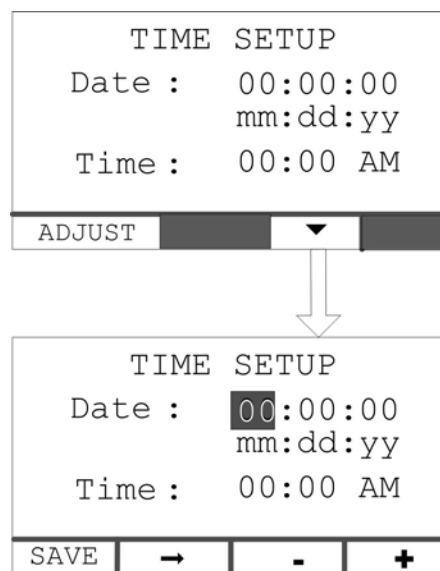

FIGURE 18. TIME SETUP SCREEN

Updating Daylight Saving Adjust Screens

Update Values on the Daylight Saving Adjust Screen

1. From any Information Menu, hold down the up and down arrows simultaneously for two seconds. The Service Menu appears.
2. Navigate to the Genset Service Menu.
3. Select **Clock Exerciser** to access the Time Setup screen.
4. Press the down key on the Time Setup screen to access the Daylight Saving Adjust screen.
5. Select **Adjust**. When updating these settings, the functions of the keys are as follows:

TABLE 16. KEY FUNCTIONS ON THE DAYLIGHT SAVING ADJUST SCREEN

Key/Button	Function
Horizontal right arrow key	Select successive blocks for editing settings on the screen
Left arrow key	Return to the previous screen
+ or - keys	Adjust values on the Adjust screen of the Daylight Saving Adjust screen
Save button	Save any changes; after saving, the Save button changes to the Adjust button

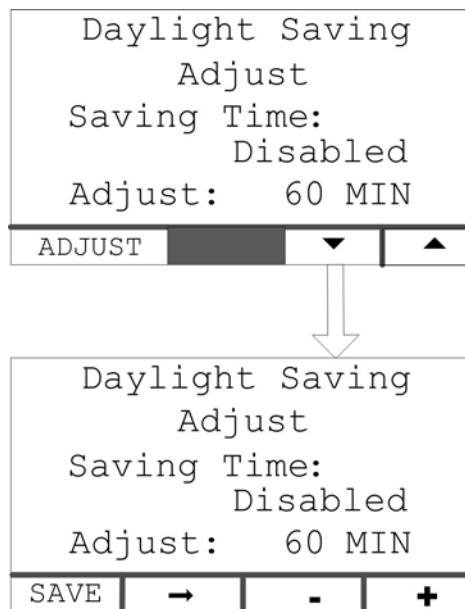

FIGURE 19. "DAYLIGHT SAVING ADJUST SAVING TIME" SCREEN NAVIGATION

Access and Update the Daylight Saving Adjust Start Screen

1. Press the down arrow key on the Daylight Saving Adjust screen.
2. Press **Adjust**. When updating these settings, the functions of the keys are as follows:

TABLE 17. KEY FUNCTIONS ON THE DAYLIGHT SAVING ADJUST START SCREEN

Key/Button	Function
Horizontal right arrow key	Select successive blocks for editing settings on the screen
+ or - keys	Adjust Month, Week, Day or Hour
Save button	Save any changes; after saving, the Save button changes to the Adjust button

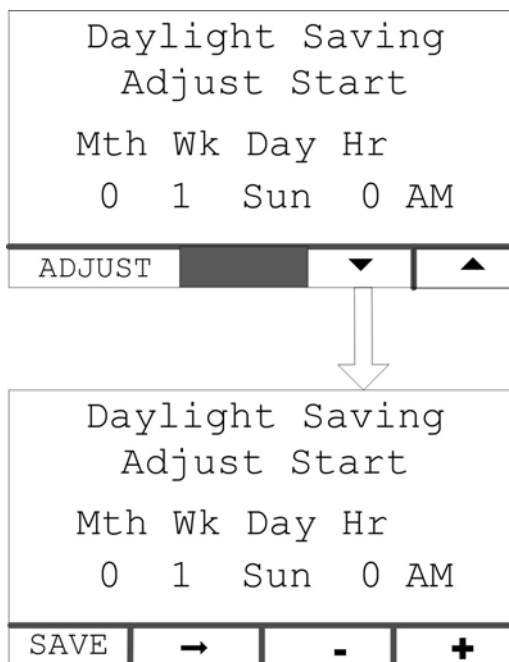

FIGURE 20. DAYLIGHT SAVING ADJUST START SCREEN

Update the Daylight Saving Adjust End Screen

1. Press the down key on the Daylight Saving Adjust Start screen.
2. Press **Adjust**. When updating these settings, the functions of the keys are as follows:

TABLE 18. KEY FUNCTIONS ON THE DAYLIGHT SAVING ADJUST END SCREEN

Key/Button	Function
Horizontal right arrow key	Select successive blocks for editing settings on the screen
+ or - keys	Adjust Month, Week, Day or Hour
Save button	Save any changes; after saving, the Save button changes to the Adjust button

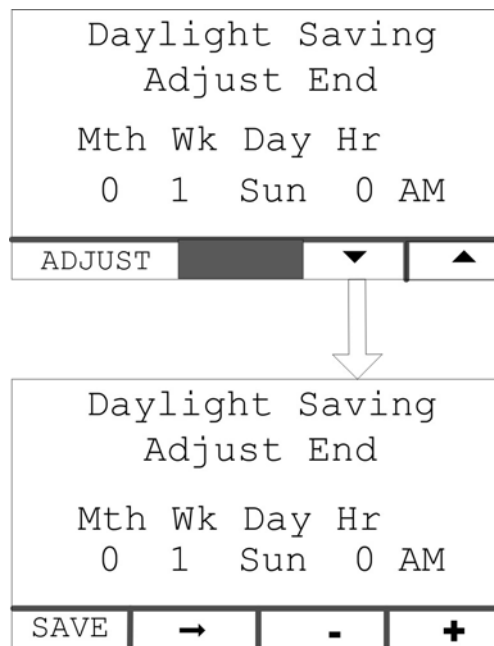

FIGURE 21. DAYLIGHT SAVING ADJUST END SCREEN

5.2 Exercise Settings

NOTICE

When battery power is lost, these settings must be reset.

NOTICE

Not applicable without a single phase RA series transfer switch.

To access the Clock/Exerciser Menu:

1. From any Information Menu, hold down the up and down arrows simultaneously for two seconds. The Service Menu appears.
2. Navigate through the screens to find and select **Clock/Excr** in the Service Menu.

NOTICE

The following screens represent the standard operator panel (that is, HMI211). If using an in-home operator panel, which may be additionally purchased as an option, the screens may look slightly different. This procedure applies to both operator panels.

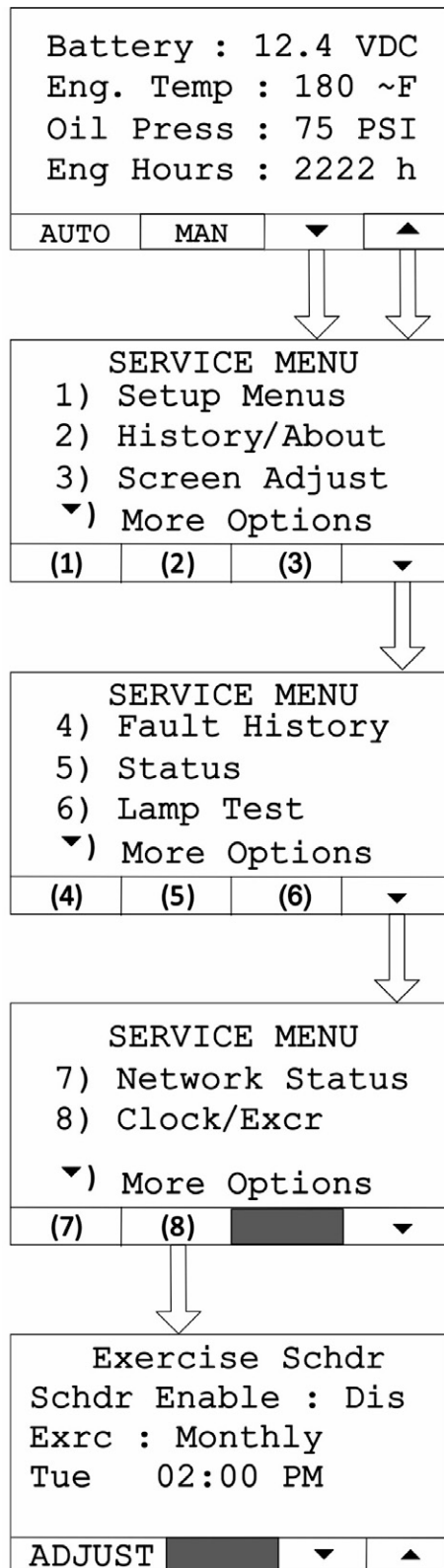

FIGURE 22. CLOCK/EXERCISER MENU NAVIGATION

Updating Exercise Frequency (1-Phase ATS)

NOTICE**Not applicable without a single phase RA series transfer switch.**

To update the exercise frequency and dates on the Clock/Exerciser Menu:

1. From any Information Menu, hold down the up and down arrows simultaneously for two seconds. The Service Menu appears.
2. Access the Time Setup screen by selecting **Clock Exerciser** on the Genset Service Menu.
3. Press the down key on the Time Setup screen to access the Daylight Saving Adjust screen.
4. Select **Adjust**.
5. Press the down key on the Daylight Saving Adjust Start screen.
6. Select **Adjust**.
7. Press **Exercise Schdr** on the Daylight Saving Adjust End screen.
8. Press **Adjust**.

When updating these settings, the functions of the keys are as follows:

- The horizontal right arrow key is used to select successive blocks for editing settings on the screen.
- Use the + or - keys to edit the following settings:
 - Schdr Enable: Enable or Disable
 - Exercise Schedule: Semi-Annual (every six months), Quarterly, Monthly, Bi-Monthly (the first and third week of every month based on the time set when the Bi-Monthly option is selected), or Weekly
 - Exercise Schedule: Day, Hours, Minutes, AM/PM
- Press **Save** to save any changes. After saving, the Save button changes to the Adjust button.

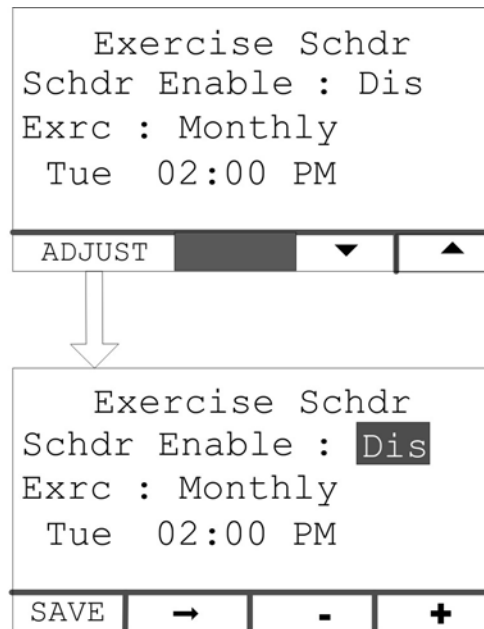

FIGURE 23. EXERCISE FREQUENCY NAVIGATION

Updating Exercise Duration (1-Phase ATS)

NOTICE

Not applicable without a single phase RA series transfer switch.

To update the exercise duration on the Clock/Exerciser Menu:

1. From any Information Menu, hold down the up and down arrows simultaneously for two seconds. The Service Menu appears.
2. Access the Time Setup screen by selecting **Clock Exerciser** on the Genset Service Menu.
3. Press the down key on the Time Setup screen to access the Daylight Saving Adjust screen.
4. Select **Adjust**.
5. Press the down key on the Daylight Saving Adjust Start screen.
6. Select **Adjust**.
7. Press **Exercise Schdr** on the Daylight Saving Adjust End screen.
8. Press the down key on the Exercise Schdr Menu.
9. Press **Adjust**.

When updating these settings, the functions of the keys are as follows:

- The horizontal right arrow key is used to select the duration block for editing exercise duration.
- Use the + or - keys to edit the exercise duration minutes.

- Press **Save** to save any changes. After saving, the Save button changes to the Adjust button.

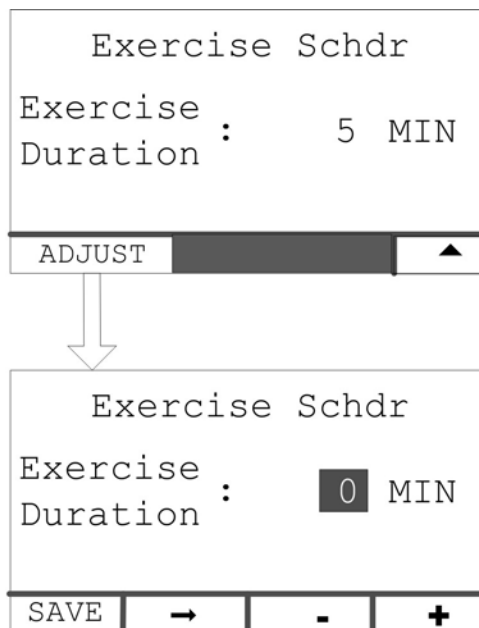

FIGURE 24. EXERCISE DURATION NAVIGATION

5.3 Brightness and Contrast

The Screen Adjust screen allows the contrast, brightness, and units to be set. To access the Screen Adjust screen:

1. From any Information screen, hold down the up and down arrows simultaneously for two seconds to gain access to the Service Menu screen.
2. Select **Screen Adjust**.

To adjust the contrast, brightness, or units from the Screen Adjust screen:

1. From the Screen Adjust screen, select **Adjust** to access the screen variables.
2. Press the right arrow to move between the variables.
3. Adjust settings, and press **Save** to save any changes.

When updating these settings, the functions of the keys are as follows:

- The horizontal right arrow key is used to select successive blocks for editing settings on the screen.
- Select the left arrow to return to the previous screen.
- Adjust values by using the + or - keys on the Adjust screen of the Display Setup screen.
- Press **Save** to save any changes. After saving, the Save button changes to the Adjust button.

NOTICE

The following screens represent the standard operator panel (HMI211). If using an in-home operator panel, which may be additionally purchased as an option, the screens may look slightly different. This procedure applies to both operator panels.

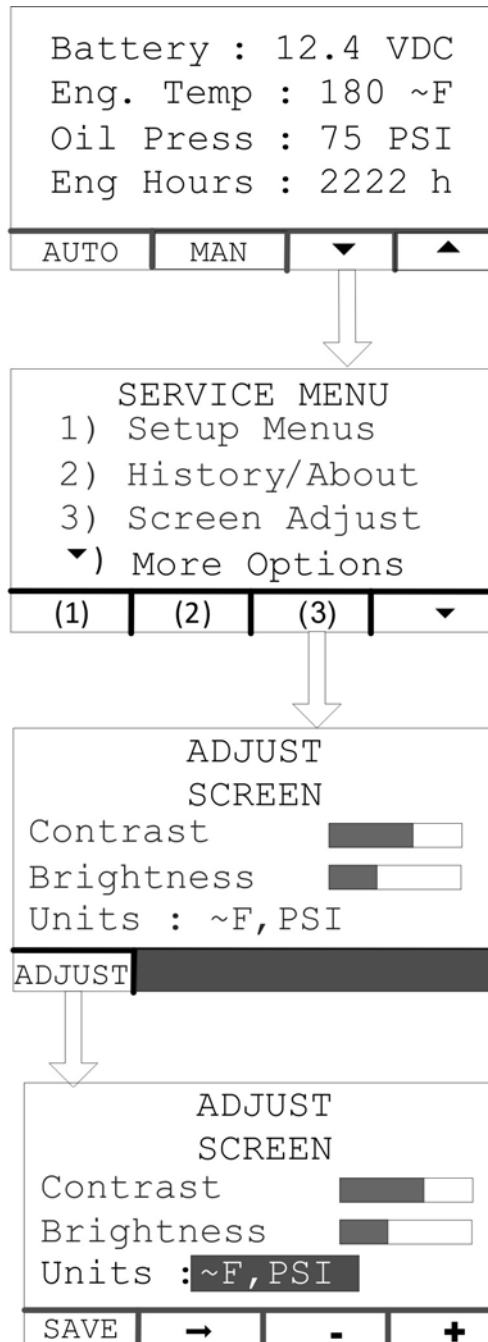

FIGURE 25. BRIGHTNESS AND CONTRAST SCREEN NAVIGATION

NOTICE

Adjusting the brightness on the operator panel adjusts the brightness of both the LCD backlight and the LEDs on the display. The contrast should never be 0 or 100% on any of the screens. The default value for Brightness is 50%.

5.4 History and About Menu

To access the History/About screen:

1. From any Information Menu, hold down the up and down arrows simultaneously for two seconds. The Service Menu appears.
2. Select **History/About**.
3. Advance through the screens to view information about the generator set, control, and display.

NOTICE

The following screens represent the standard operator panel (HMI211). If using an in-home operator panel, which may be additionally purchased as an option, the screens may look slightly different. This procedure applies to both operator panels.

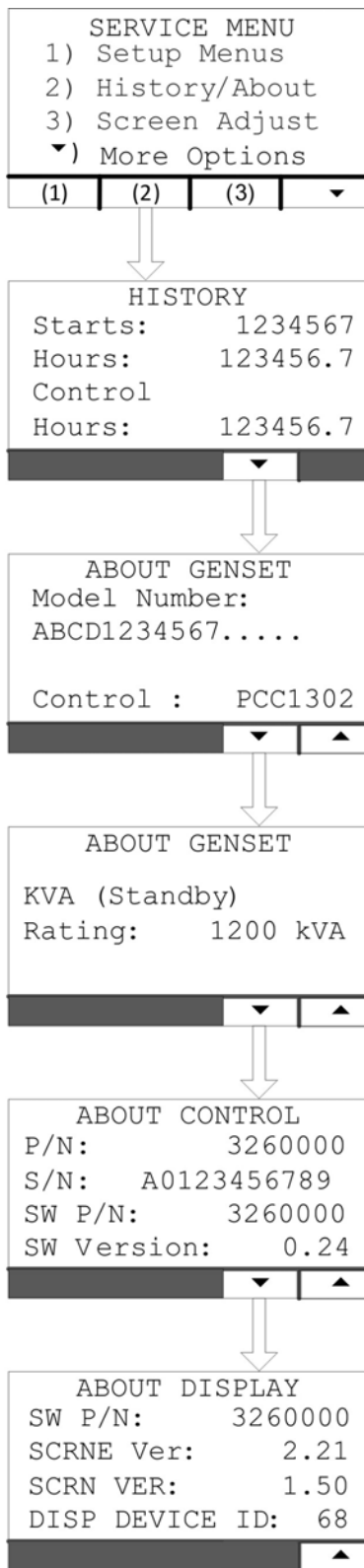

FIGURE 26. HISTORY/ABOUT MENU

5.5 InPower Service Tool

The InPower™ service tool can be used in troubleshooting to perform tests, verify control inputs and outputs, and test protective functions. Refer to the InPower User's Guide, provided with the InPower software for test procedures.

Disabling the AMF Feature

NOTICE

This procedure must be performed by a qualified technician.

On single-phase units, the control is shipped with the Automatic Mains Failure (AMF) feature enabled. This feature has logic to control the RA Automatic Transfer Switch (ATS), including a 5-minute retransfer to utility delay. If you are not using an RA ATS, you can eliminate the 5-minute retransfer to utility delay by disabling the AMF feature using the instructions below.

NOTICE

This procedure is optional. If you do not disable the AMF feature, the generator set will just run for an additional 5 minutes after the utility has been restored.

NOTICE

These steps cannot be performed with the HMI211; they can only be performed with the InPower service tool.

1. Connect to the PCC 1.1 or PCC 2.3 via InPower.
2. Navigate to the Adjustments->Features->Automatic Transfer Switch folder.
3. Select the Auto Mains Failure Enable parameter.
4. Double-click on Enabled in the Value field.
5. A pop-up will appear with available choices. Select Disabled.
6. Select Device->Save Adjustments from the top menu bar.
7. A pop-up will appear asking if the change is to be saved. Click the Save button.
8. After a pop-up appears confirming that the change has been saved, disconnect InPower from the PCC1302.

5.6 Installation Checklist

Tick	Item
	General
	Generator set wattage capacity is sufficient to handle maximum anticipated load.
	At least 5 feet of clearance to combustible materials is provided. At least 3 feet of clearance is provided around the entire generator set for service and ventilation.
	The generator set is located in an area not subject to flooding.
	All installers have read and are familiar with the Generator Set Installation manual and the Health and Safety manual.
	All installers have been thoroughly briefed on preventive maintenance procedures.
	All installers have read and understand all important safety instructions.
	Generator Set Support
	The floor, roof or earth on which the generator set rests is strong enough and will not allow shifting or movement. Local codes for soil bearing capacity were followed.
	The generator set is properly supported and secured to an approved base.
	The supporting base is of non-combustible material and extends 6 inches all around the generator set.
	Fuel System
	Verify that the generator set is configured to the fuel being used. (See the Fuel Selection and Fuel System Connection section.)
	Fuel line size has been verified for generator set fuel consumption and pressure.
	Approved flexible fuel line is installed between main fuel supply and the generator set's fuel system near the generator set
	Fuel lines are properly installed, supported and protected against damage.
	Fuel supply shutoff valves are installed to turn off fuel flow in case of leaks.
	No leaks are found in fuel supply line as a result of leak testing fuel systems.
	The inside of all fuel supply lines is free of contaminants.
	Fuel pressure is at 6-13 inches of water column (1.5 - 3.2 kPa) under any condition.
	Fuel pressure maintains at least 6 inches water column (1.5 kPa) when the generator set is at rated load.
	The installation is compliant with all state and local codes and regulations.
	AC and DC Wiring
	Wire sizes, wire types, insulation, conduits and connection methods all meet applicable codes.

Tick	Item
	AC and DC wires are separated in their own conduit to prevent electrical induction.
	All load, line and generator connections are well made and correct.
	Generator Set Pre-Start
	A safety check was performed just before starting.
	The generator set engine is properly serviced with oil and coolant.
	The battery is properly installed, serviced and charged.
	The battery charger and engine coolant heater are connected and operational, if applicable.
	All generator set covers and safety shields are installed correctly.
	The fuel supply is turned on.
	All fuel shutoff valves are operational.
	The date and time have been set in the generator set control.
	The generator set operating mode has been selected.

5.7 Startup

WARNING

Automated Machinery

Accidental or remote starting of the generator set can cause severe personal injury or death.

Isolate all auxiliary supplies and use an insulated wrench to disconnect the starting battery cables, negative (-) cable first.

After verifying that the installation was completed correctly, start and test the system. Make sure to connect the battery cables to the battery with the positive (+) cable first.

Read through the Operator Manual and perform the maintenance and pre-start checks as instructed.

The following information applies to C70 N6, C80 N6, and C100 N6 generator set models only: Adaptive learn is an engine ECM function that allows the generator set to "learn" its environment. There are small differences in the performance of each engine and fuel system component, so the ECM uses inputs from the engine sensors to adjust running conditions to operate more consistently for each individual generator set. After installation is complete and while testing the overall system function, the generator set must be run with no active faults under load (that is, transfer switch connected to maximum customer load available) until the engine temperature reaches 80 °C (175 °F) to allow the adaptive learn function to initialize.

The generator set is shipped from the factory with the proper level of engine oil and coolant, but each should be checked before the generator set is started. Start and operate the generator set following all the instructions and precautions in the Operator Manual. Ensure that the bonding bolts are installed into the service panels before leaving the site.

NOTICE

Before leaving the site, if the generator set is ready to be placed in service, put the generator set in Auto mode to provide automatic standby power.

NOTICE

Contact your local Cummins service representative if you encounter a fault code.

This page is intentionally blank.

Appendix A. Fuel Line Selection

Table of Contents

Table 20. Required Information for Determining Fuel Line Size	74
Table 22. NFPA Equivalent Lengths of Pipe Fittings and Valves in Feet (Meters)	75
Table 24. Natural Gas Schedule 40 Metallic Pipe Sizing in Inches	77
Table 27. Natural Gas Semirigid Copper Tubing Sizing	78
Table 30. Propane Vapor Schedule 40 Metallic Pipe Sizing	80
Table 33. Propane Vapor Semirigid Copper Tubing Sizing	82
Table 36. Propane Schedule 40 Iron Pipe Sizing, Liquid Withdrawal (Maximum Capacity of Pipe in Cubic Feet of Gas per Hour)*	83
Figure 27. Minimum LPG Tank Size (50% Full) Required to Maintain 5 PSIG at Specific Withdrawal Rate and Minimum Expected Winter Temperature	85

A.0 Fuel System Pipe Sizing Introduction

Incorrect fuel line size may cause the generator set to not run or provide full power output.

Tables are included in this section to help calculate pipe sizing for natural gas and propane vapor withdrawal under specified conditions. Consult NFPA 54 or other applicable codes for other operating conditions or other fuel system installation requirements.

Refer to the *Engineering Application Manual T-030: Liquid Cooled Generator Sets* manual (A040S369) for more information.

To determine the optimal fuel line size, the following information is needed:

TABLE 20. REQUIRED INFORMATION FOR DETERMINING FUEL LINE SIZE

Category	Description
Fuel Flow Requirements for the Generator Set	Fuel flow requirements have a large impact on fuel line size.
Fuel Source (Natural Gas or Propane Vapor)	Fuel sources can affect fuel line size. Natural gas installations generally require a higher fuel flow rate compared to propane vapor installations, since propane has a higher energy content.
Fuel Line Length (Including Fittings)	As fuel line lengths increase, they may require larger diameter fuel lines. Be sure to consider the equivalent length of all of the fittings (elbows, tees, valves) in the installation in addition to the straight pipe length.
Fuel Line Type (e.g., Copper Tubing or Iron Pipe)	Most fuel line types are iron pipe or copper tubing. Be sure to use the sizing chart for the fuel line type when sizing the fuel line.

NOTICE

NFPA 54 has selection tables for other approved fuel lines. Verify with the authorities having jurisdiction the allowed fuel line type for the generator set installation.

A.1 Gas Pipe Sizing

NOTICE

The following tables in this section are reprinted with permission from NFPA 54-2015, *National Fuel Gas Code*, Copyright © 2014, National Fire Protection Association.

- Natural Gas Schedule 40 Metallic Pipe Sizing
- Natural Gas Semirigid Copper Tubing Sizing
- Propane Vapor Schedule 40 Iron Pipe Sizing
- Propane Vapor Semirigid Copper Tubing Sizing
- Propane Schedule 40 Iron Pipe Sizing, Liquid Withdrawal (Maximum Capacity of Pipe in Cubic Feet of Gas per Hour)

This reprinted material is not the complete and official position of the NFPA on the referenced subject, which is represented only by the standard in its entirety.

Sizing of gas piping for proper fuel delivery, both flow and pressure, can become quite complex. A simplified method is to convert all fittings, valves, etc. to equivalent lengths of pipe in the diameter(s) being considered. The total equivalent length can then be related to flow capacity. Equivalent lengths of pipe fittings and valves can be found in the table below.

TABLE 22. NFPA EQUIVALENT LENGTHS OF PIPE FITTINGS AND VALVES IN FEET (METERS)

Type of Fitting	Nominal Inch (Millimeters) Pipe Size								
	1/2 (15)	3/4 (20)	1 (25)	1-1/4 (32)	1-1/2 (40)	2 (50)	2-1/2 (65)	3 (80)	4 (100)
90° Std. Elbow or Tee Reduced 1/2.	1.6 (0.5)	2.0 (0.6)	2.6 (0.8)	3.3 (1.0)	4.0 (1.2)	5.0 (1.5)	6.0 (1.8)	7.5 (2.3)	10.0 (3.1)
90° Long Radius Elbow or Straight Run Tee	1.0 (0.3)	1.4 (0.4)	1.7 (0.5)	2.3 (0.7)	2.6 (0.8)	3.3 (1.0)	4.1 (1.3)	5.0 (1.5)	6.7 (2.0)
45° Elbow	0.8 (0.2)	0.9 (0.3)	1.3 (0.4)	1.7 (0.5)	2.1 (0.6)	2.6 (0.8)	3.2 (1.0)	4.0 (1.2)	5.2 (1.6)
180° Std. Bend	2.5 (0.8)	3.2 (1.0)	4.1 (1.2)	5.6 (1.7)	6.3 (1.9)	8.2 (2.5)	10.0 (3.1)	12.0 (3.7)	17.0 (5.2)
TEE, Side Inlet or Outlet	3.0 (0.9)	4.0 (1.2)	5.0 (1.5)	7.0 (2.1)	8.0 (2.4)	10.0 (3.0)	12.0 (3.7)	15.0 (4.6)	21.0 (6.4)

Type of Fitting	Nominal Inch (Millimeters) Pipe Size								
	1/2 (15)	3/4 (20)	1 (25)	1-1/4 (32)	1-1/2 (40)	2 (50)	2-1/2 (65)	3 (80)	4 (100)
Foot Valve and Strainer	3.7 (1.1)	4.9 (1.5)	7.5 (2.3)	8.9 (2.7)	11.0 (3.4)	15.0 (4.6)	18.0 (5.5)	22.0 (6.7)	29.0 (8.8)
Swing Check Valve, Fully Open	6.0 (1.8)	8.0 (2.4)	10.0 (3.0)	14.0 (4.3)	16.0 (4.9)	20.0 (6.1)	25.0 (7.6)	30.0 (9.1)	40.0 (12.2)
Globe Valve, Fully Open	18.0 (5.5)	22.0 (6.7)	29.0 (8.8)	38.0 (11.6)	43.0 (13.1)	55.0 (16.8)	69.0 (21.0)	84.0 (25.6)	120.0 (36.6)
Angle Valve, Fully Open	7.0 (2.1)	9.0 (2.7)	12.0 (3.7)	15.0 (4.6)	18.0 (5.5)	24.0 (7.3)	29.0 (8.8)	35.0 (10.7)	47.0 (14.3)
Gate Valve, Fully Open	0.7 (0.2)	0.9 (0.3)	1.0 (0.3)	1.5 (0.5)	1.8 (0.5)	2.3 (0.7)	2.8 (0.9)	3.2 (1.0)	4.5 (1.4)

The remaining tables in this section show maximum gas capacity for equivalent lengths of various pipe sizes.

Here are some basic but very important steps that all installers must follow to make sure that fuel lines are sized correctly:

1. Verify adequate fuel flow, quality, and pressure available from the natural gas utility connection or the propane system.
2. Obtain the maximum fuel consumption requirements at full load for the specific generator set from the Model Specifications section and for all gas appliances attached to the pipe system.
3. Make a list of all the fittings and valves in the proposed system used in this generator set installation.
4. Determine the equivalent length of all fuel line fittings (elbows, tees, and valves). (See the NFPA Pipe Fittings table in this appendix to determine the equivalent lengths for all fuel line fittings.)
5. Add the equivalent length of the fuel line fittings to the lengths of straight pipe to determine the total equivalent length of the system.
6. Choose the applicable table in this appendix based on the fuel type (natural gas, propane vapor or liquid propane) and fuel line material.
7. Determine the fuel line size at full load:
 - a. Locate the equivalent length of pipe (or next larger equivalent length) in the left hand column.
 - b. Move across the row to where the maximum flow capacity number is as large or larger than the maximum fuel consumption.
 - c. Move to the top of that column to where the minimum nominal pipe size or tubing size required **for the system as designed** is shown.

TABLE 24. NATURAL GAS SCHEDULE 40 METALLIC PIPE SIZING IN INCHES

Gas:	Natural
Inlet Pressure:	Less than 2 psi
Pressure Drop:	0.5 in. water column
Specific Gravity:	0.6

Nominal:	Pipe Size													
	1/2	3/4	1	1 1/4	1 1/2	2	2 1/2	3	4	5	6	8	10	12
Actual ID:	0.622	0.824	1.049	1.38	1.61	2.067	2.469	3.068	4.026	5.047	6.065	7.981	10.02	11.938
Length (ft)	Capacity in Cubic Feet of Gas per Hour													
10	172	360	678	1390	2090	4020	6400	11300	23100	41800	67600	139000	252000	399000
20	118	247	466	957	1430	2760	4400	7780	15900	28700	46500	95500	173000	275000
30	95	199	374	768	1150	2220	3530	6250	12700	23000	37300	76700	139000	220000
40	81	170	320	657	985	1900	3020	5350	10900	19700	31900	65600	119000	189000
50	72	151	284	583	873	1680	2680	4740	9660	17500	28300	58200	106000	167000
60	65	137	257	528	791	1520	2430	4290	8760	15800	25600	52700	95700	152000
70	60	126	237	486	728	1400	2230	3950	8050	14600	23600	48500	88100	139000
80	56	117	220	452	677	1300	2080	3670	7490	13600	22000	45100	81900	130000
90	52	110	207	424	635	1220	1950	3450	7030	12700	20600	42300	76900	122000
100	50	104	195	400	600	1160	1840	3260	6640	12000	19500	40000	72600	115000
125	44	92	173	355	532	1020	1630	2890	5890	10600	17200	35400	64300	102000
150	40	83	157	322	482	928	1480	2610	5330	9650	15600	32100	58300	92300
175	37	77	144	296	443	854	1360	2410	4910	8880	14400	29500	53600	84900
200	34	71	134	275	412	794	1270	2240	4560	8260	13400	27500	49900	79000
250	30	63	119	244	366	704	1120	1980	4050	7320	11900	24300	44200	70000
300	27	57	108	221	331	638	1020	1800	3670	6630	10700	22100	40100	63400
350	25	53	99	203	305	587	935	1650	3370	6100	9880	20300	36900	58400
400	23	49	92	189	283	546	870	1540	3140	5680	9190	18900	34300	54300
450	22	46	86	177	266	512	816	1440	2940	5330	8620	17700	32200	50900
500	21	43	82	168	251	484	771	1360	2780	5030	8150	16700	30400	48100
550	20	41	78	159	239	459	732	1290	2640	4780	7740	15900	28900	45700
600	19	39	74	152	228	438	699	1240	2520	4560	7380	15200	27500	43600

650	18	38	71	145	218	420	669	1180	2410	4360	7070	14500	26400	41800
700	17	36	68	140	209	403	643	1140	2320	4190	6790	14000	25300	40100
750	17	35	66	135	202	389	619	1090	2230	4040	6540	13400	24400	38600
800	16	34	63	130	195	375	598	1060	2160	3900	6320	13000	23600	37300
850	16	33	61	126	189	363	579	1020	2090	3780	6110	12600	22800	36100
900	15	32	59	122	183	352	561	992	2020	3660	5930	12200	22100	35000
950	15	31	58	118	178	342	545	963	1960	3550	5760	11800	21500	34000
1000	14	30	56	115	173	333	530	937	1910	3460	5600	11500	20900	33100
1100	14	28	53	109	164	316	503	890	1810	3280	5320	10900	19800	31400
1200	13	27	51	104	156	301	480	849	1730	3130	5070	10400	18900	30000
1300	12	26	49	100	150	289	460	813	1660	3000	4860	9980	18100	28700
1400	12	25	47	96	144	277	442	781	1590	2880	4670	9590	17400	27600
1500	11	24	45	93	139	267	426	752	1530	2780	4500	9240	16800	26600
1600	11	23	44	89	134	258	411	727	1480	2680	4340	8920	16200	25600
1700	11	22	42	86	130	250	398	703	1430	2590	4200	8630	15700	24800
1800	10	22	41	84	126	242	386	682	1390	2520	4070	8370	15200	24100
1900	10	21	40	81	122	235	375	662	1350	2440	3960	8130	14800	23400
2000	NA	20	39	79	119	229	364	644	1310	2380	3850	7910	14400	22700

TABLE 27. NATURAL GAS SEMIRIGID COPPER TUBING SIZING

Gas:	Natural
Inlet Pressure:	Less than 2 psi
Pressure Drop:	0.5 in. water column
Specific Gravity:	0.6

	Tube Size (in.)								
Nominal K & L:	1/4	3/8	1/2	5/8	3/4	1	1 1/4	1 1/2	2
Nominal ACR:	3/8	1/2	5/8	3/4	7/8	1 1/8	1 3/8	—	—
Outside:	0.375	0.5	0.625	0.75	0.875	1.125	1.375	1.625	2.125
Inside:*	0.305	0.402	0.527	0.652	0.745	0.995	1.245	1.481	1.959
Length (ft.)	Capacity in Cubic Feet of Gas per Hour								
10	27	55	111	195	276	590	1,060	1,680	3,490

20	18	38	77	134	190	406	730	1,150	2,400
30	15	30	61	107	152	326	586	925	1,930
40	13	26	53	92	131	279	502	791	1,650
50	11	23	47	82	116	247	445	701	1,460
60	10	21	42	74	105	224	403	635	1,320
70	NA	19	39	68	96	206	371	585	1,220
80	NA	18	36	63	90	192	345	544	1,130
90	NA	17	34	59	84	180	324	510	1,060
100	NA	16	32	56	79	170	306	482	1,000
125	NA	14	28	50	70	151	271	427	890
150	NA	13	26	45	64	136	245	387	806
175	NA	12	24	41	59	125	226	356	742
200	NA	11	22	39	55	117	210	331	690
250	NA	NA	20	34	48	103	186	294	612
300	NA	NA	18	31	44	94	169	266	554
350	NA	NA	16	28	40	86	155	245	510
400	NA	NA	15	26	38	80	144	228	474
450	NA	NA	14	25	35	75	135	214	445
500	NA	NA	13	23	33	71	128	202	420
550	NA	NA	13	22	32	68	122	192	399
600	NA	NA	12	21	30	64	116	183	381
650	NA	NA	12	20	29	62	111	175	365
700	NA	NA	11	20	28	59	107	168	350
750	NA	NA	11	19	27	57	103	162	338
800	NA	NA	10	18	26	55	99	156	326
850	NA	NA	10	18	25	53	96	151	315
900	NA	NA	NA	17	24	52	93	147	306
950	NA	NA	NA	17	24	50	90	143	297
1,000	NA	NA	NA	16	23	49	88	139	289
1,100	NA	NA	NA	15	22	46	84	132	274
1,200	NA	NA	NA	15	21	44	80	126	262
1,300	NA	NA	NA	14	20	42	76	120	251

1,400	NA	NA	NA	13	19	41	73	116	241
1,500	NA	NA	NA	13	18	39	71	111	232
1,600	NA	NA	NA	13	18	38	68	108	224
1,700	NA	NA	NA	12	17	37	66	104	217
1,800	NA	NA	NA	12	17	36	64	101	210
1,900	NA	NA	NA	11	16	35	62	98	204
2,000	NA	NA	NA	11	16	34	60	95	199

NA: A flow of less than 10 cfh.

Note: All table entries are rounded to 3 significant digits.

*Table capacities are based on Type K copper tubing inside diameter (shown), which has the smallest inside diameter of the copper tubing products.

TABLE 30. PROPANE VAPOR SCHEDULE 40 METALLIC PIPE SIZING

Gas:	Undiluted Propane
Inlet Pressure:	11.0 in. water column
Pressure Drop:	0.5 in. water column
Specific Gravity:	1.5
INTENDED USE: Pipe Sizing Between Single- or Second-Stage (Low-Pressure) Regulator and Appliance	

Nominal Inside:	Pipe Size (in.)								
	1/2	3/4	1	1 1/4	1 1/2	2	2 1/2	3	4
Actual:	0.622	0.824	1.049	1.38	1.61	2.067	2.469	3.068	4.026
Length (ft.)	Capacity in Thousands of BTU per Hour								
10	291	608	1,150	2,350	3,520	6,790	10,800	19,100	39,000
20	200	418	787	1,620	2,420	4,660	7,430	13,100	26,800
30	160	336	632	1,300	1,940	3,750	5,970	10,600	21,500
40	137	287	541	1,110	1,660	3,210	5,110	9,030	18,400
50	122	255	480	985	1,480	2,840	4,530	8,000	16,300
60	110	231	434	892	1,340	2,570	4,100	7,250	14,800
80	101	212	400	821	1,230	2,370	3,770	6,670	13,600
100	94	197	372	763	1,140	2,200	3,510	6,210	12,700
125	89	185	349	716	1,070	2,070	3,290	5,820	11,900

150	84	175	330	677	1,010	1,950	3,110	5,500	11,200
175	74	155	292	600	899	1,730	2,760	4,880	9,950
200	67	140	265	543	814	1,570	2,500	4,420	9,010
250	62	129	243	500	749	1,440	2,300	4,060	8,290
300	58	120	227	465	697	1,340	2,140	3,780	7,710
350	51	107	201	412	618	1,190	1,900	3,350	6,840
400	46	97	182	373	560	1,080	1,720	3,040	6,190
450	42	89	167	344	515	991	1,580	2,790	5,700
500	40	83	156	320	479	922	1,470	2,600	5,300
550	37	78	146	300	449	865	1,380	2,440	4,970
600	35	73	138	283	424	817	1,300	2,300	4,700
650	33	70	131	269	403	776	1,240	2,190	4,460
700	32	66	125	257	385	741	1,180	2,090	4,260
750	30	64	120	246	368	709	1,130	2,000	4,080
800	29	61	115	236	354	681	1,090	1,920	3,920
850	28	59	111	227	341	656	1,050	1,850	3,770
900	27	57	107	220	329	634	1,010	1,790	3,640
950	26	55	104	213	319	613	978	1,730	3,530
1,000	25	53	100	206	309	595	948	1,680	3,420
1,100	25	52	97	200	300	578	921	1,630	3,320
1,200	24	50	95	195	292	562	895	1,580	3,230
1,300	23	48	90	185	277	534	850	1,500	3,070
1,400	22	46	86	176	264	509	811	1,430	2,930
1,500	21	44	82	169	253	487	777	1,370	2,800
1,600	20	42	79	162	243	468	746	1,320	2,690
1,700	19	40	76	156	234	451	719	1,270	2,590
1,800	19	39	74	151	226	436	694	1,230	2,500
1,900	18	38	71	146	219	422	672	1,190	2,420
2,000	18	37	69	142	212	409	652	1,150	2,350
Note: All table entries are rounded to 3 significant digits.									

TABLE 33. PROPANE VAPOR SEMIRIGID COPPER TUBING SIZING

Gas:	Undiluted Propane
Inlet Pressure:	11.0 in. water column
Pressure Drop:	0.5 in. water column
Specific Gravity:	1.5
INTENDED USE: Tube Sizing Between Single- or Second-Stage (Low-Pressure) Regulator and Appliance	

	Tube Size (in.)								
Nominal K& L:	1/4	3/8	1/2	5/8	3/4	1	1 1/4	1 1/2	2
Nominal ACR:	3/8	1/2	5/8	3/4	7/8	1 1/8	1 3/8	—	—
Outside:	0.375	0.5	0.625	0.75	0.875	1.125	1.375	1.625	2.125
Inside:*	0.305	0.402	0.527	0.652	0.745	0.995	1.245	1.481	1.959
Length (ft.)	Capacity in Thousands of BTU per Hour								
10	45	93	188	329	467	997	1,800	2,830	5,890
20	31	64	129	226	321	685	1,230	1,950	4,050
30	25	51	104	182	258	550	991	1,560	3,250
40	21	44	89	155	220	471	848	1,340	2,780
50	19	39	79	138	195	417	752	1,180	2,470
60	17	35	71	125	177	378	681	1,070	2,240
70	16	32	66	115	163	348	626	988	2,060
80	15	30	61	107	152	324	583	919	1,910
90	14	28	57	100	142	304	547	862	1,800
100	13	27	54	95	134	287	517	814	1,700
125	11	24	48	84	119	254	458	722	1,500
150	10	21	44	76	108	230	415	654	1,360
175	NA	20	40	70	99	212	382	602	1,250
200	NA	18	37	65	92	197	355	560	1,170
250	NA	16	33	58	82	175	315	496	1,030
300	NA	15	30	52	74	158	285	449	936
350	NA	14	28	48	68	146	262	414	861
400	NA	13	26	45	63	136	244	385	801

450	NA	12	24	42	60	127	229	361	752
500	NA	11	23	40	56	120	216	341	710
550	NA	11	22	38	53	114	205	324	674
600	NA	10	21	36	51	109	196	309	643
650	NA	NA	20	34	49	104	188	296	616
700	NA	NA	19	33	47	100	180	284	592
750	NA	NA	18	32	45	96	174	274	570
800	NA	NA	18	31	44	93	168	264	551
850	NA	NA	17	30	42	90	162	256	533
900	NA	NA	17	29	41	87	157	248	517
950	NA	NA	16	28	40	85	153	241	502
1,000	NA	NA	16	27	39	83	149	234	488
1,100	NA	NA	15	26	37	78	141	223	464
1,200	NA	NA	14	25	35	75	135	212	442
1,300	NA	NA	14	24	34	72	129	203	423
1,400	NA	NA	13	23	32	69	124	195	407
1,500	NA	NA	13	22	31	66	119	188	392
1,600	NA	NA	12	21	30	64	115	182	378
1,700	NA	NA	12	20	29	62	112	176	366
1,800	NA	NA	11	20	28	60	108	170	355
1,900	NA	NA	11	19	27	58	105	166	345
2,000	NA	NA	11	19	27	57	102	161	335

NA: A flow of less than 10,000 BTU/hr.

Note: All table entries are rounded to 3 significant digits.

*Table capacities are based on Type K copper tubing inside diameter (shown), which has the smallest inside diameter of the copper tubing products.

TABLE 36. PROPANE SCHEDULE 40 IRON PIPE SIZING, LIQUID WITHDRAWAL (MAXIMUM CAPACITY OF PIPE IN CUBIC FEET OF GAS PER HOUR)*

Equivalent Length of Pipe (ft.)	Schedule 40 Iron Pipe Size (in.): Nominal (Inside Diameter)								
	1/2 (0.622)	3/4 (0.824)	1 (1.049)	1 1/4 (1.38)	1 1/2 (1.61)	2 (2.067)	3 (3.068)	3 1/2 (3.548)	4 (4.026)
30	733	1,532	2,885	5,924	8,876	17,094	48,164	70,519	98,238
40	627	1,311	2,469	5,070	7,597	14,630	41,222	60,355	84,079

Equivalent Length of Pipe (ft.)	Schedule 40 Iron Pipe Size (in.): Nominal (Inside Diameter)								
	1/2 (0.622)	3/4 (0.824)	1 (1.049)	1 1/4 (1.38)	1 1/2 (1.61)	2 (2.067)	3 (3.068)	3 1/2 (3.548)	4 (4.026)
50	556	1,162	2,189	4,494	6,733	12,966	36,534	53,492	74,518
60	504	1,053	1,983	4,072	6,100	11,748	33,103	48,467	67,519
70	463	969	1,824	3,746	5,612	10,808	30,454	44,589	62,116
80	431	901	1,697	3,484	5,221	10,055	28,331	41,482	57,787
90	404	845	1,593	3,269	4,899	9,434	26,583	38,921	54,220
100	382	798	1,504	3,088	4,627	8,912	25,110	36,764	51,216
150	307	641	1,208	2,480	3,716	7,156	20,164	29,523	41,128
200	262	549	1,034	2,122	3,180	6,125	17,258	25,268	35,200
250	233	486	916	1,881	2,819	5,428	15,295	22,395	31,198
300	211	441	830	1,705	2,554	4,919	13,859	20,291	28,267
350	194	405	764	1,568	2,349	4,525	12,750	18,667	26,006
400	180	377	711	1,459	2,186	4,209	11,861	17,366	24,193
450	169	354	667	1,369	2,051	3,950	11,129	16,295	22,700
500	160	334	630	1,293	1,937	3,731	10,512	15,391	21,442
600	145	303	571	1,172	1,755	3,380	9,525	13,946	19,428
700	133	279	525	1,078	1,615	3,110	8,763	12,830	17,873
800	124	259	488	1,003	1,502	2,893	8,152	11,936	16,628
900	116	243	458	941	1,409	2,715	7,649	11,199	15,601
1000	110	230	433	889	1,331	2,564	7,225	10,579	14,737
1500	88	184	348	713	1,069	2,059	5,802	8,495	11,834
2000	76	158	297	611	915	1,762	4,966	7,271	10,128

*Pipe size recommendations are based on schedule 40 black iron pipe.

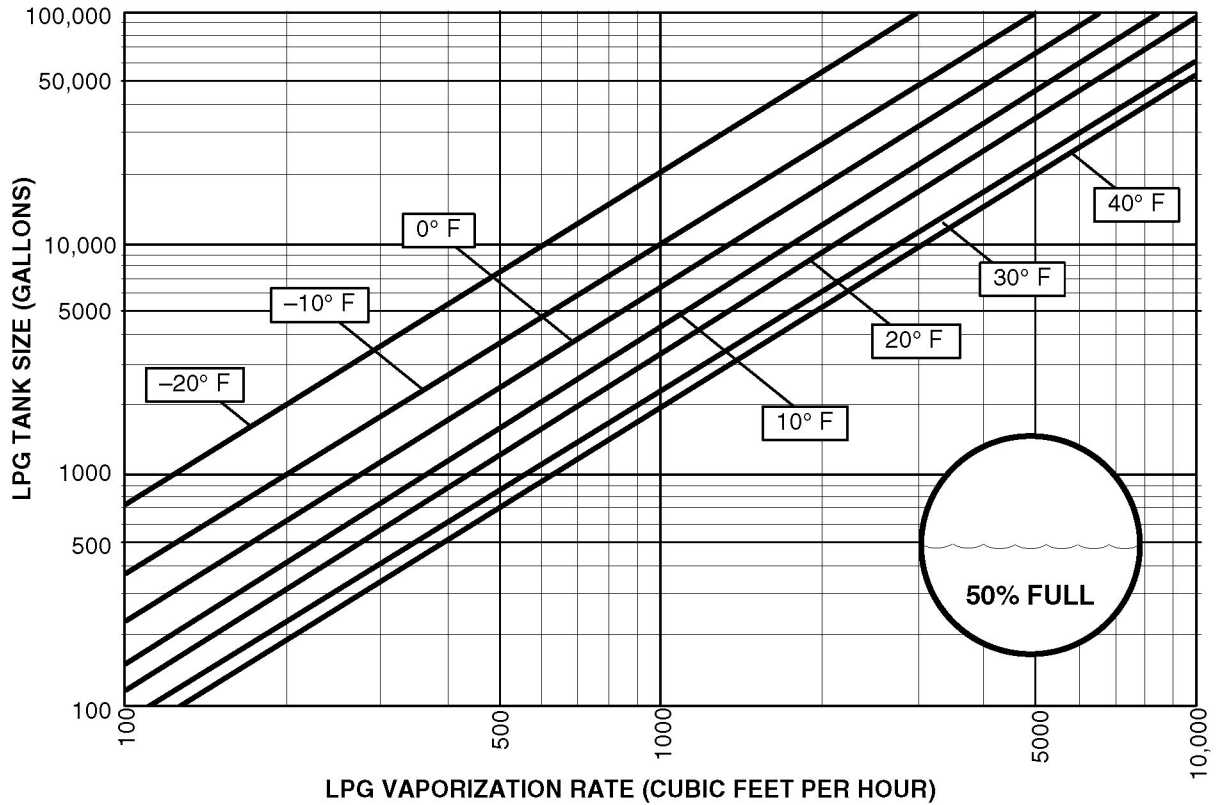

FIGURE 27. MINIMUM LPG TANK SIZE (50% FULL) REQUIRED TO MAINTAIN 5 PSIG AT SPECIFIC WITHDRAWAL RATE AND MINIMUM EXPECTED WINTER TEMPERATURE

This page is intentionally blank.

Appendix B. Outline and System Drawings

Table of Contents

Figure 28. Generator Set Outline, 20-25 kW 1800 RPM, 30 kW 3600 RPM (Sheet 1 of 2)	89
Figure 29. Generator Set Outline, 20-25 kW 1800 RPM, 30 kW 3600 RPM (Sheet 2 of 2)	90
Figure 30. Generator Set Outline, 30-40 kW 1800 RPM, 36-60 kW 3600 RPM (Sheet 1 of 2)	91
Figure 31. Generator Set Outline, 30-40 kW 1800 RPM, 36-60 kW 3600 RPM (Sheet 2 of 2)	92
Figure 32. Foundation Outline, 20-25 kW 1800 RPM, 30 kW 3600 RPM (Sheet 1 of 1)	93
Figure 33. Foundation Outline, 30-40 kW 1800 RPM, 36-60 kW 3600 RPM (Sheet 1 of 1)	94
Figure 34. Enclosure Outline, 20-25 kW 1800 RPM, 30 kW 3600 RPM (Sheet 1 of 2)	95
Figure 35. Enclosure Outline, 20-25 kW 1800 RPM, 30 kW 3600 RPM (Sheet 2 of 2)	96
Figure 36. Enclosure Outline, 30-40 kW 1800 RPM, 36-60 kW 3600 RPM (Sheet 1 of 2)	97
Figure 37. Enclosure Outline, 30-40 kW 1800 RPM, 36-60 kW 3600 RPM (Sheet 2 of 2)	98
Figure 38. Circuit Breaker Outline (Sheet 1 of 1)	99

The drawings included in this section are representative. For current complete information, refer to the drawing package that was shipped with the unit.

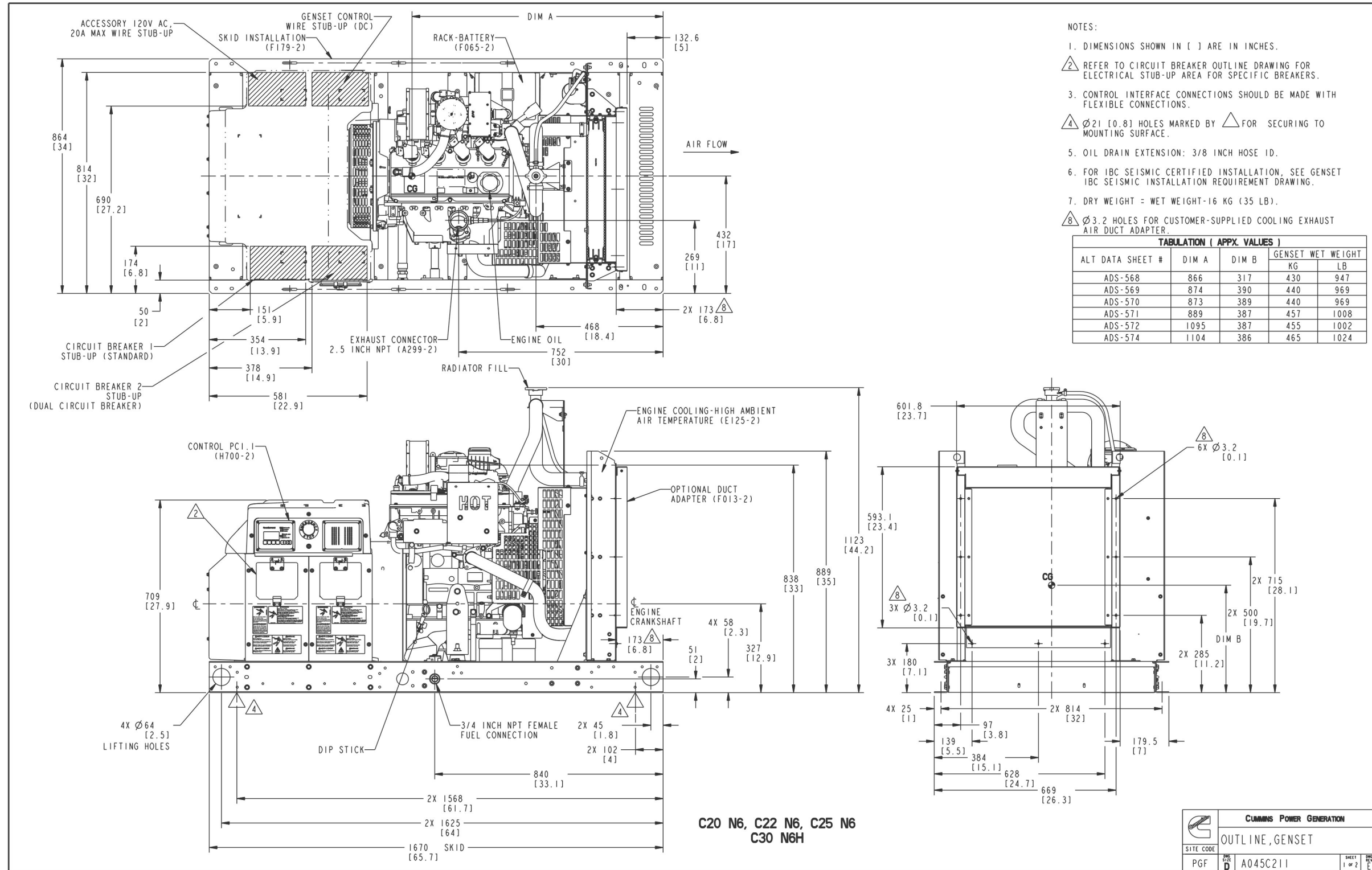

FIGURE 28. GENERATOR SET OUTLINE, 20-25 KW 1800 RPM, 30 KW 3600 RPM (SHEET 1 OF 2)

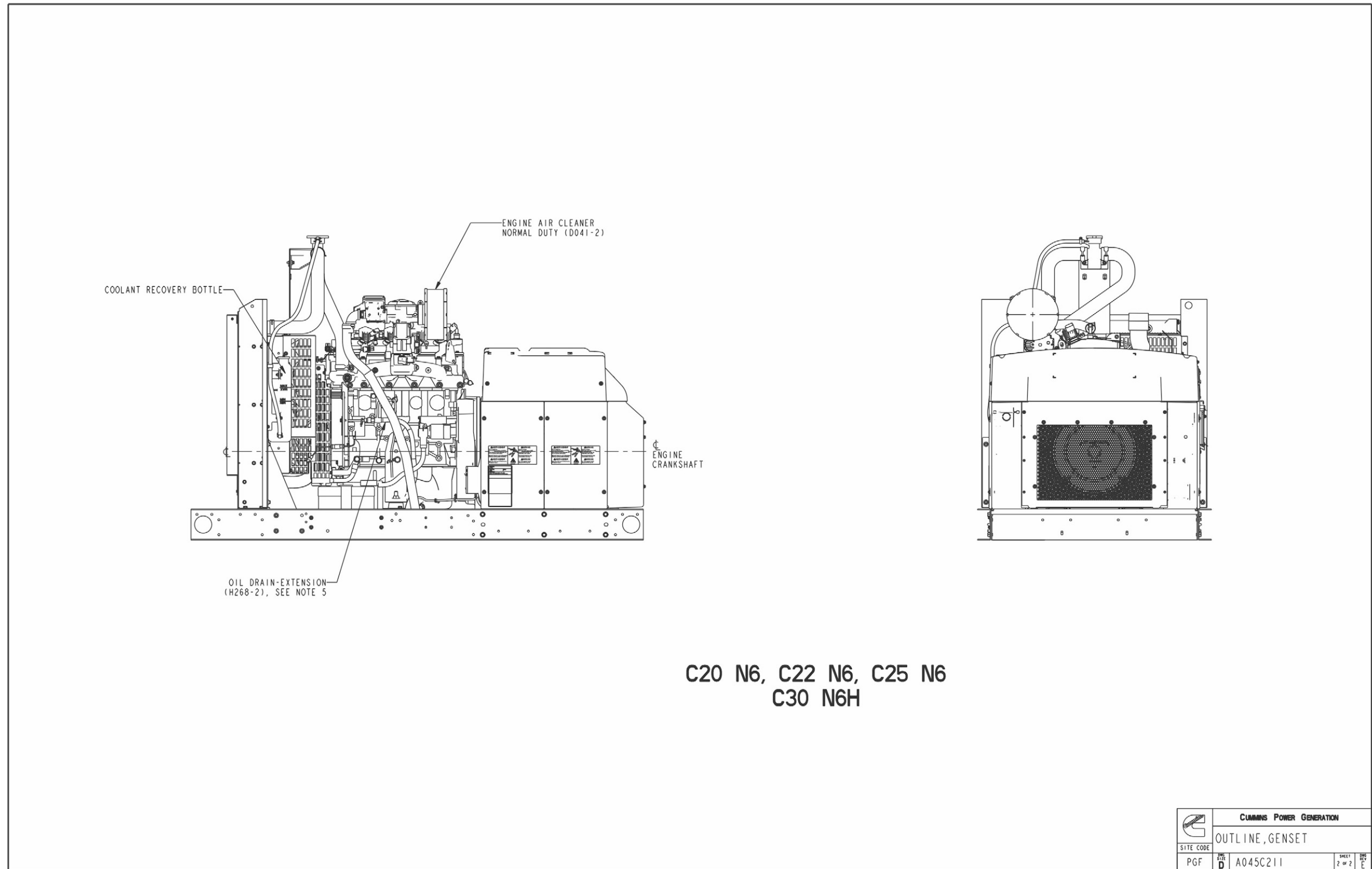

FIGURE 29. GENERATOR SET OUTLINE, 20-25 KW 1800 RPM, 30 KW 3600 RPM (SHEET 2 OF 2)

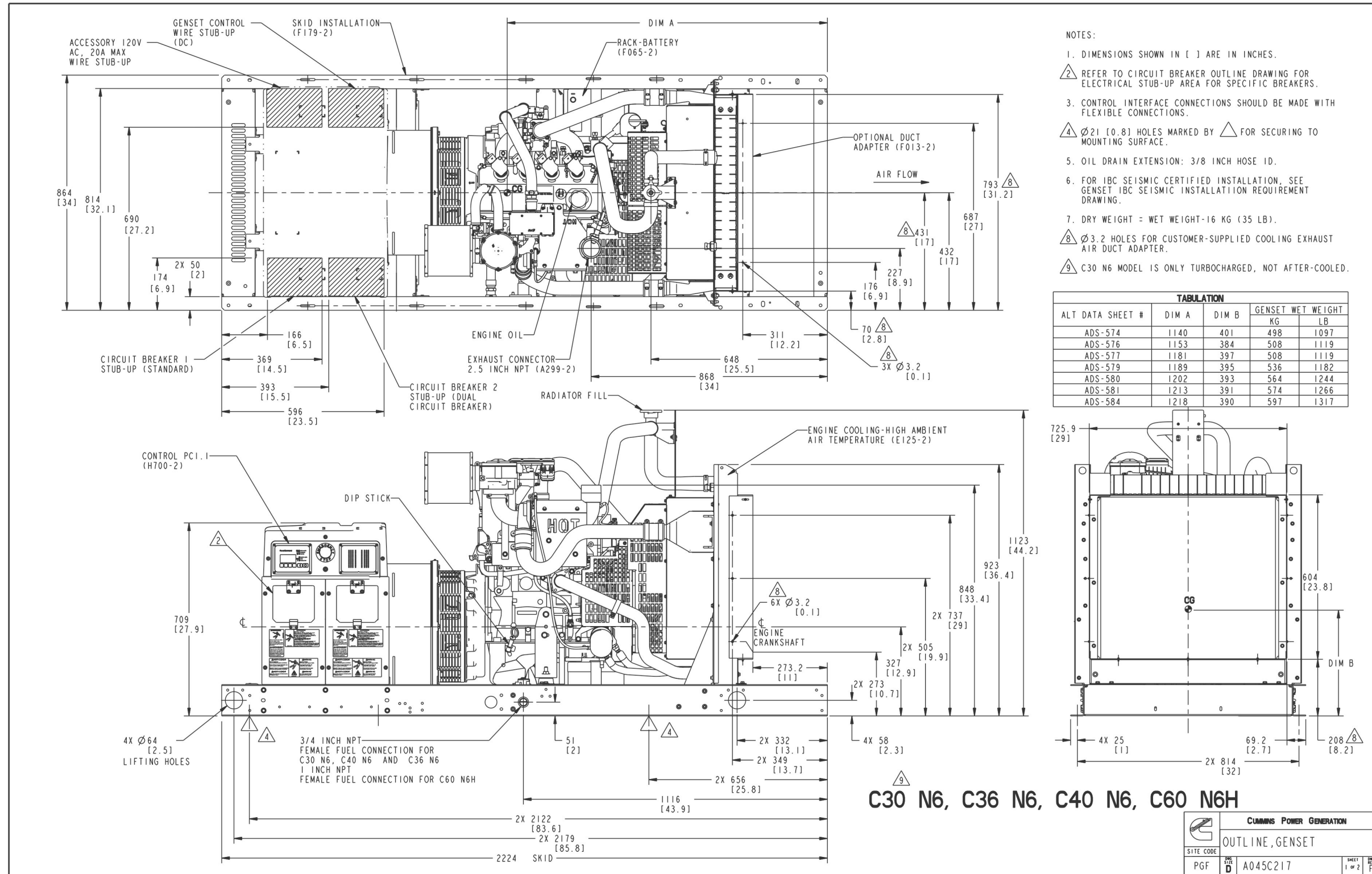

FIGURE 30. GENERATOR SET OUTLINE, 30-40 KW 1800 RPM, 36-60 KW 3600 RPM (SHEET 1 OF 2)

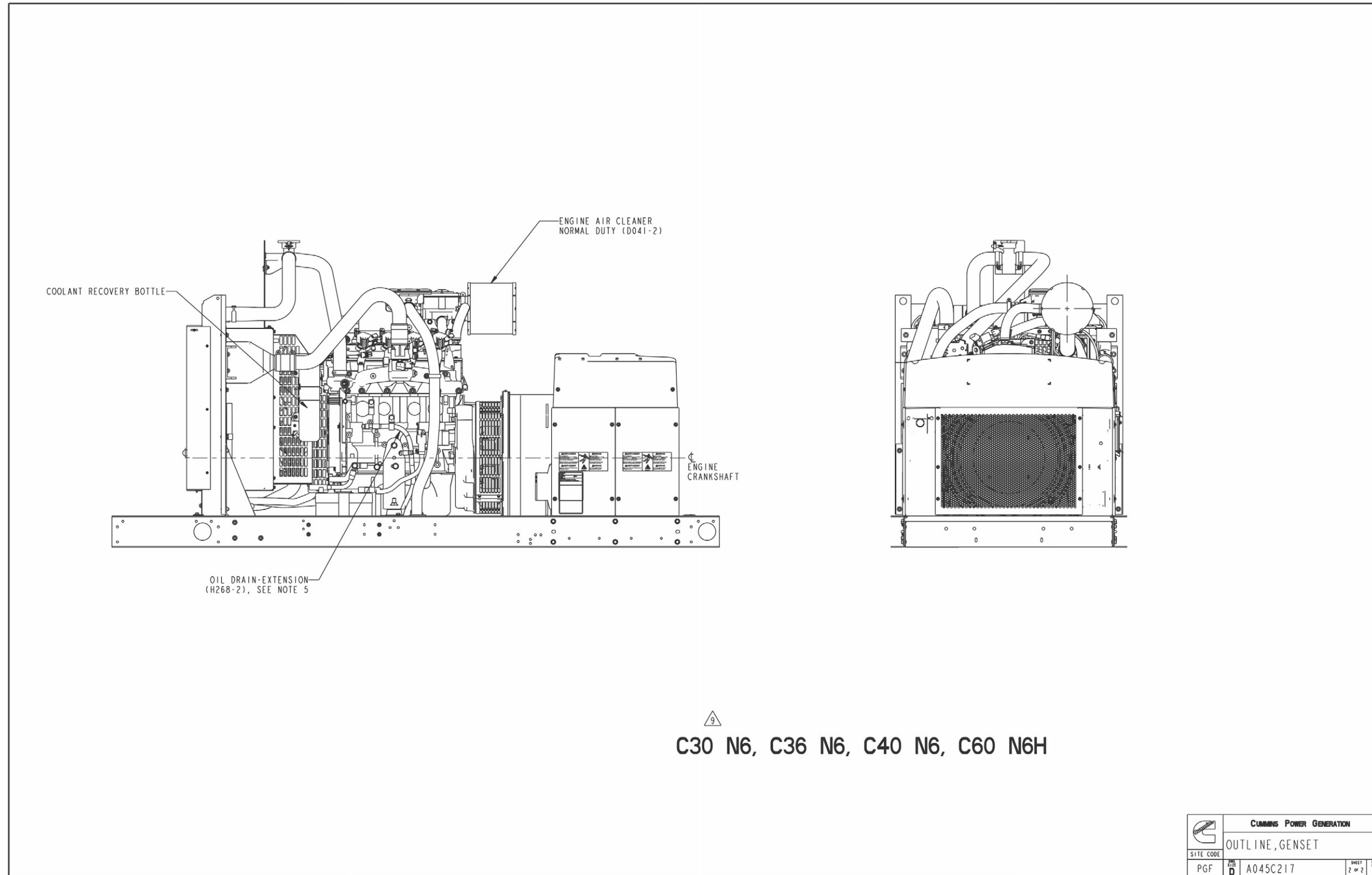

FIGURE 31. GENERATOR SET OUTLINE, 30-40 KW 1800 RPM, 36-60 KW 3600 RPM (SHEET 2 OF 2)

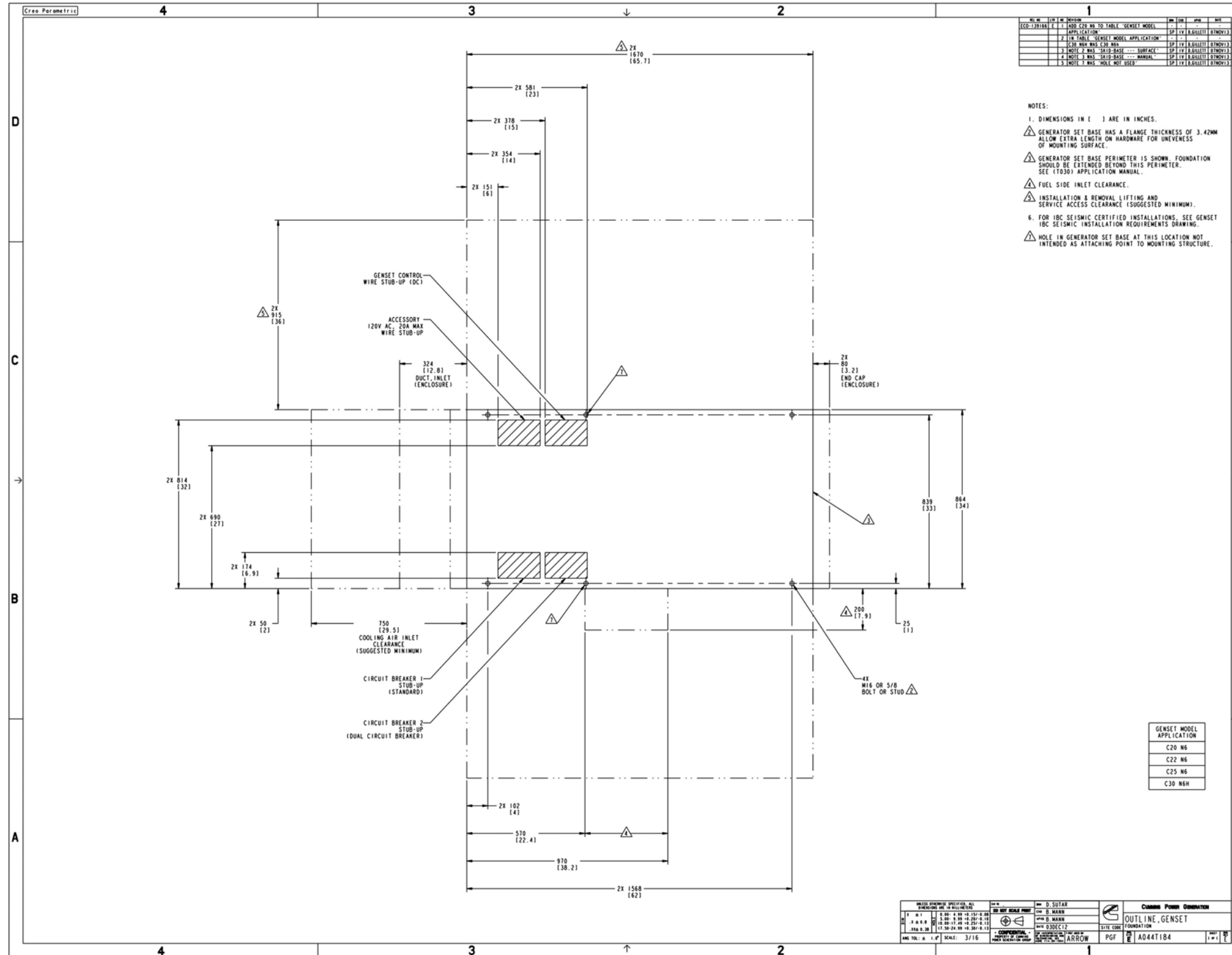

FIGURE 32. FOUNDATION OUTLINE, 20-25 KW 1800 RPM, 30 KW 3600 RPM (SHEET 1 OF 1)

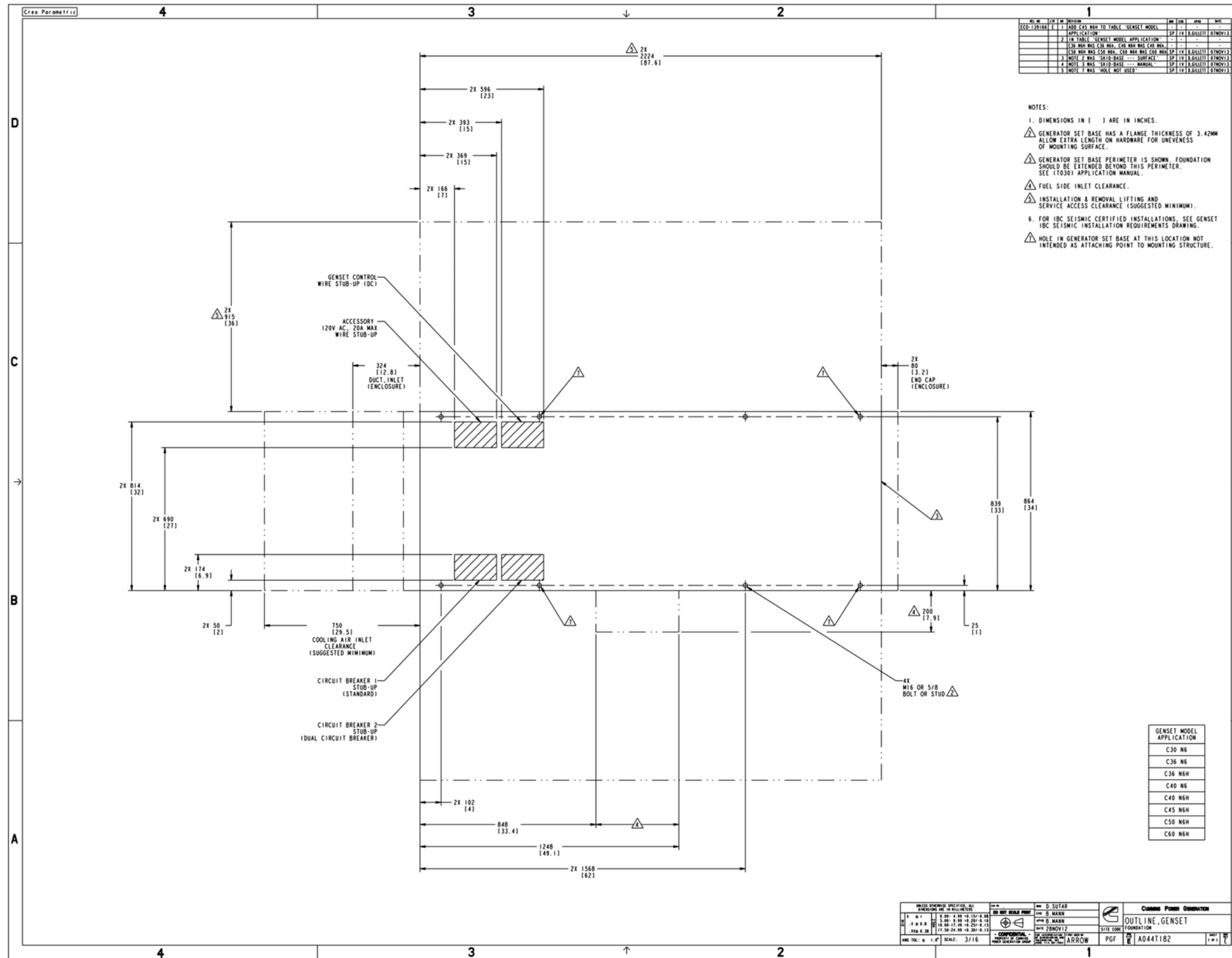

FIGURE 33. FOUNDATION OUTLINE, 30-40 KW 1800 RPM, 36-60 KW 3600 RPM (SHEET 1 OF 1)

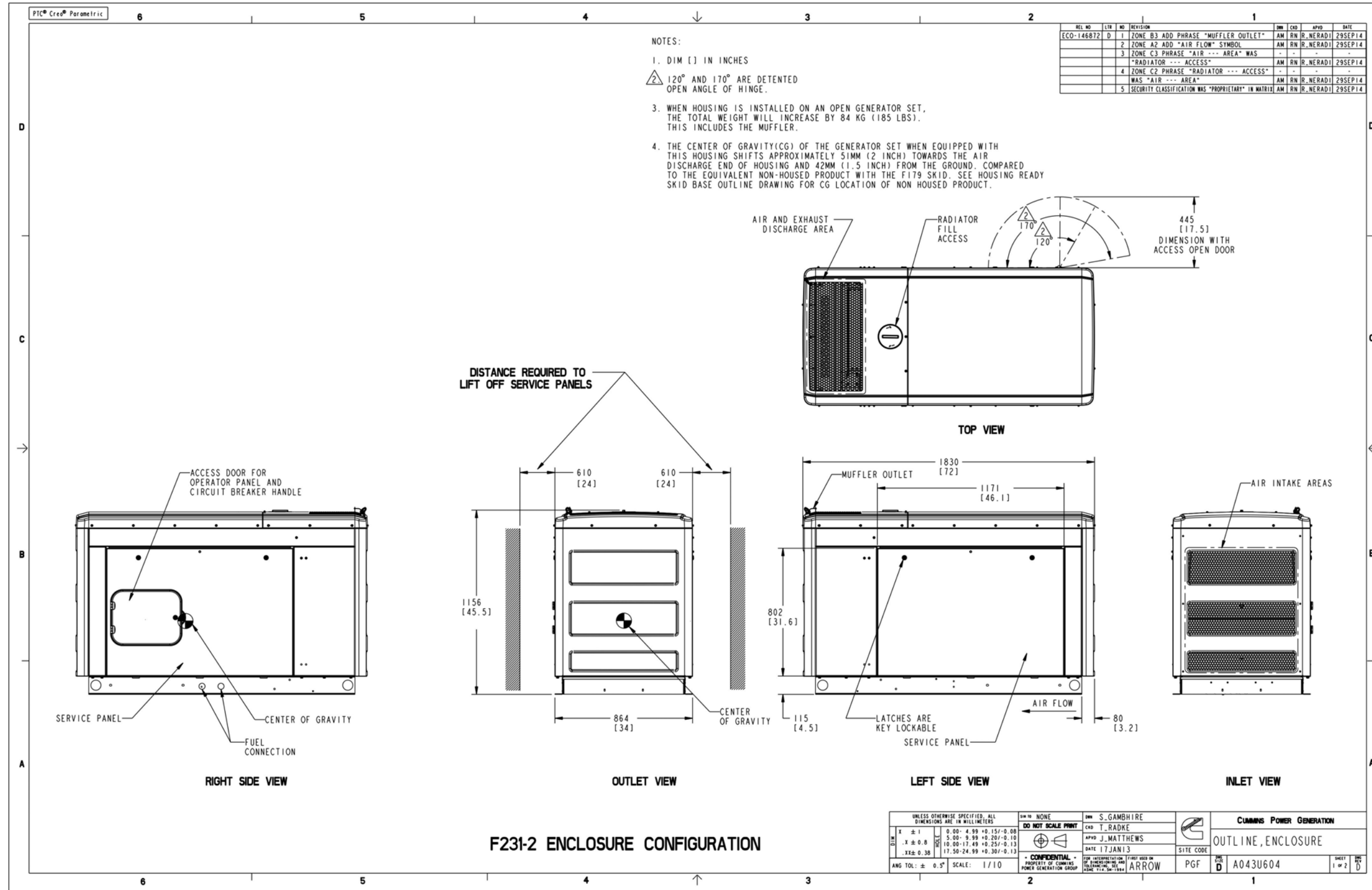

FIGURE 34. ENCLOSURE OUTLINE, 20-25 KW 1800 RPM, 30 KW 3600 RPM (SHEET 1 OF 2)

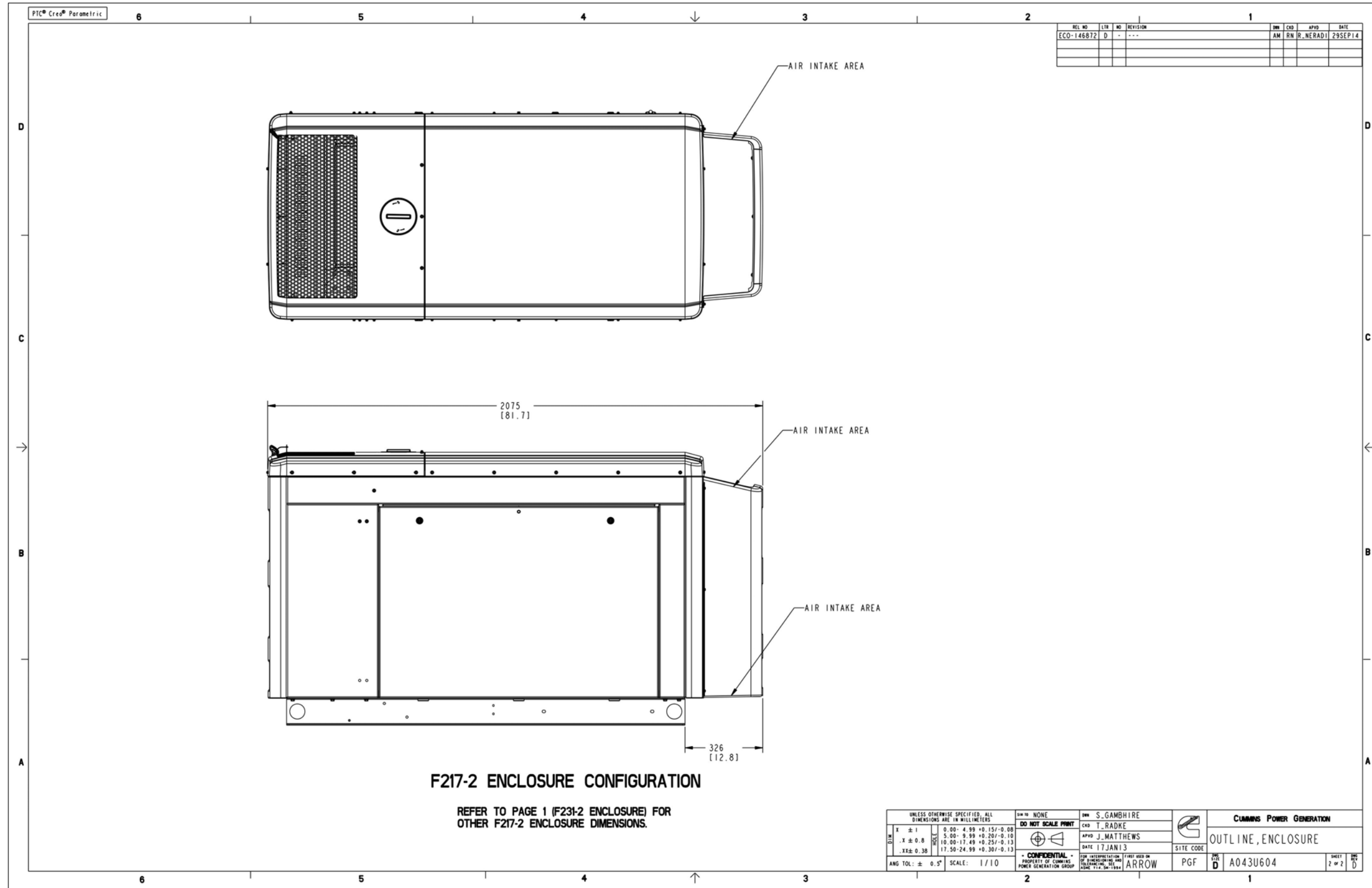

FIGURE 35. ENCLOSURE OUTLINE, 20-25 KW 1800 RPM, 30 KW 3600 RPM (SHEET 2 OF 2)

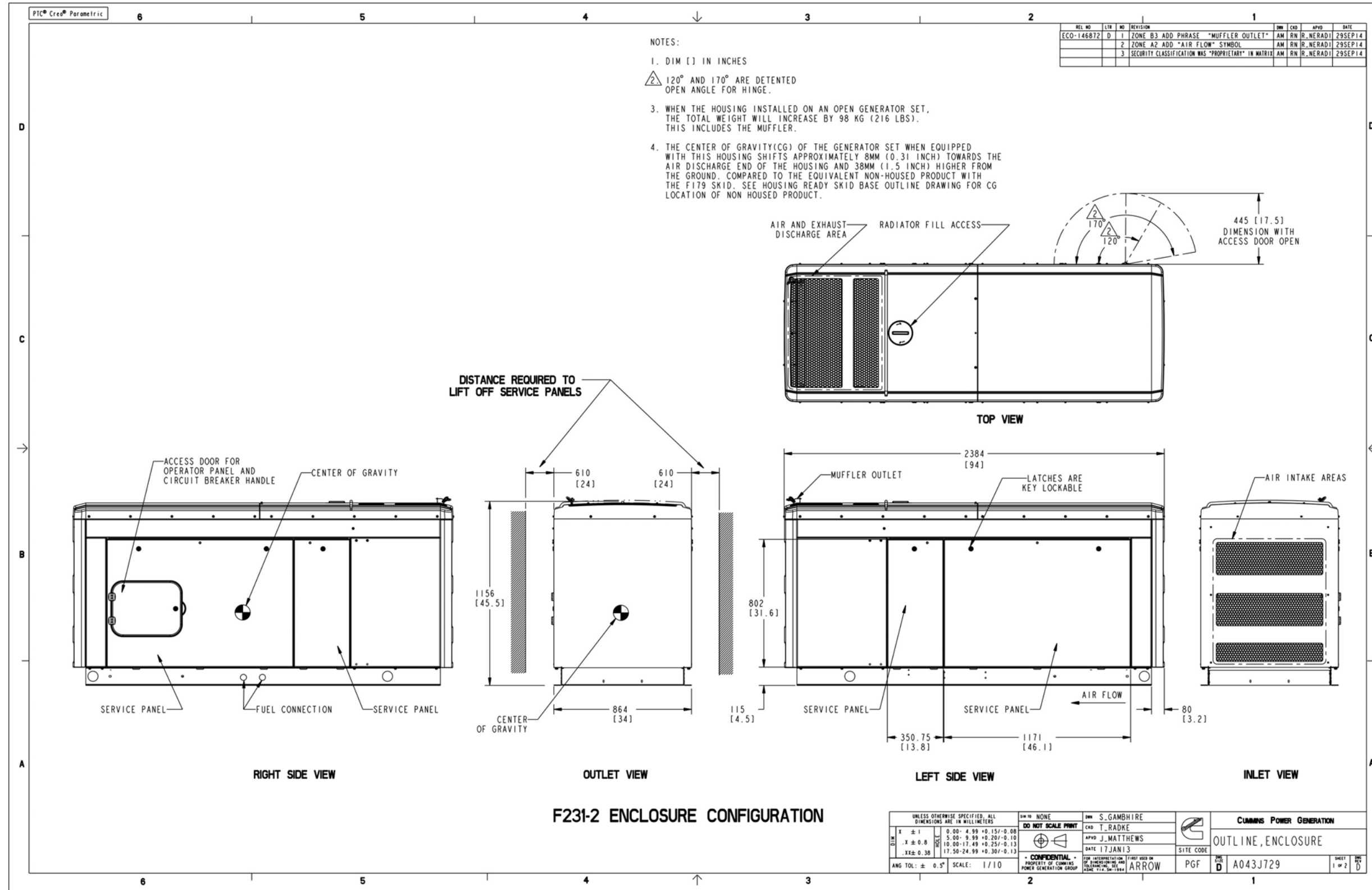

FIGURE 36. ENCLOSURE OUTLINE, 30-40 KW 1800 RPM, 36-60 KW 3600 RPM (SHEET 1 OF 2)

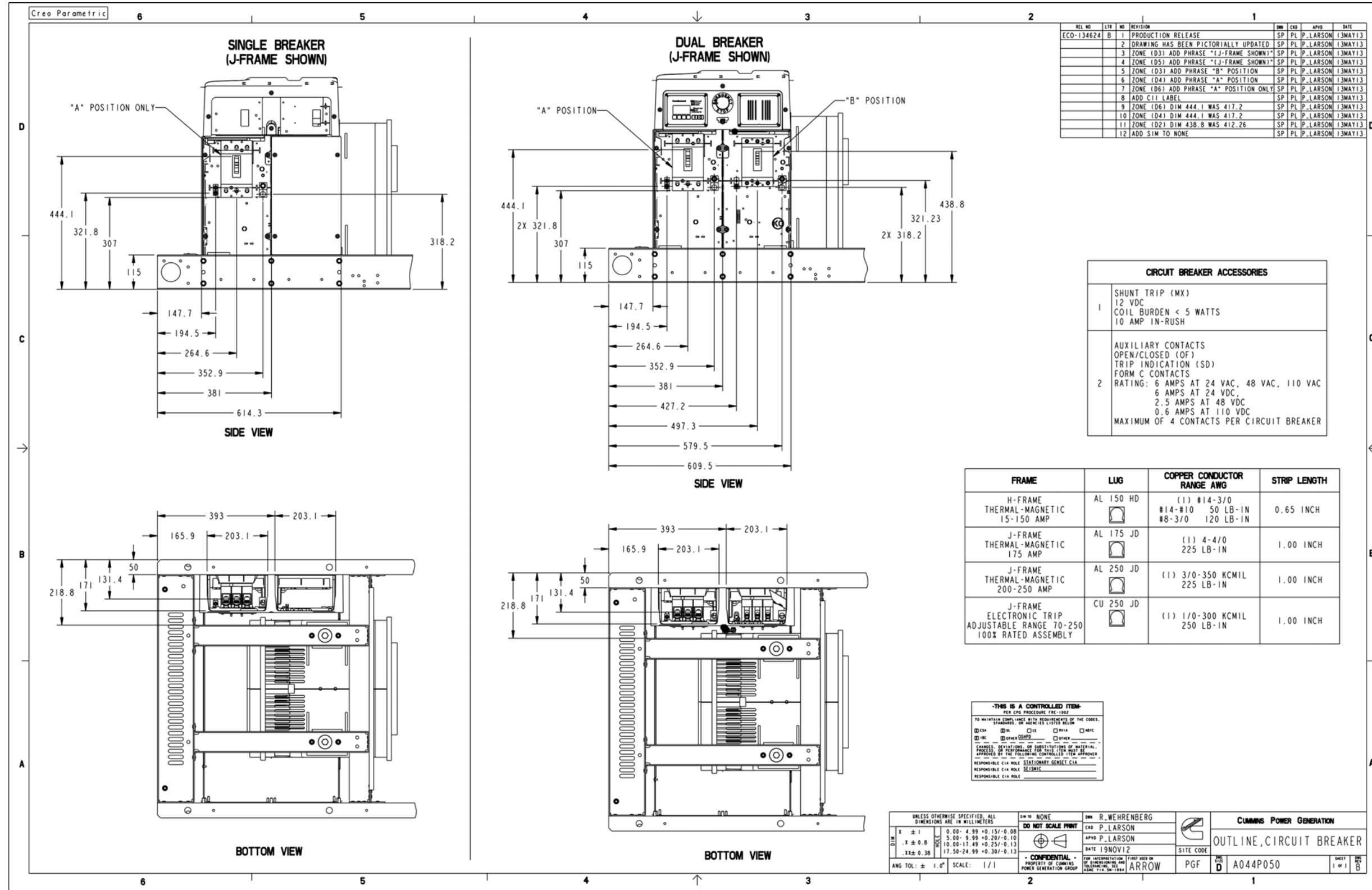

FIGURE 38. CIRCUIT BREAKER OUTLINE (SHEET 1 OF 1)

This page is intentionally blank.

Appendix C. Wiring Diagrams

Table of Contents

Figure 39. Wiring Diagram (Sheet 1 of 7)	103
Figure 40. Wiring Diagram (Sheet 2 of 7)	104
Figure 41. Wiring Diagram (Sheet 3 of 7)	105
Figure 42. Wiring Diagram (Sheet 4 of 7)	106
Figure 43. Wiring Diagram (Sheet 5 of 7)	107
Figure 44. Wiring Diagram (Sheet 6 of 7)	108
Figure 45. Wiring Diagram (Sheet 7 of 7)	109

The drawings included in this section are representative. For current complete information, refer to the drawing package that was shipped with the unit.

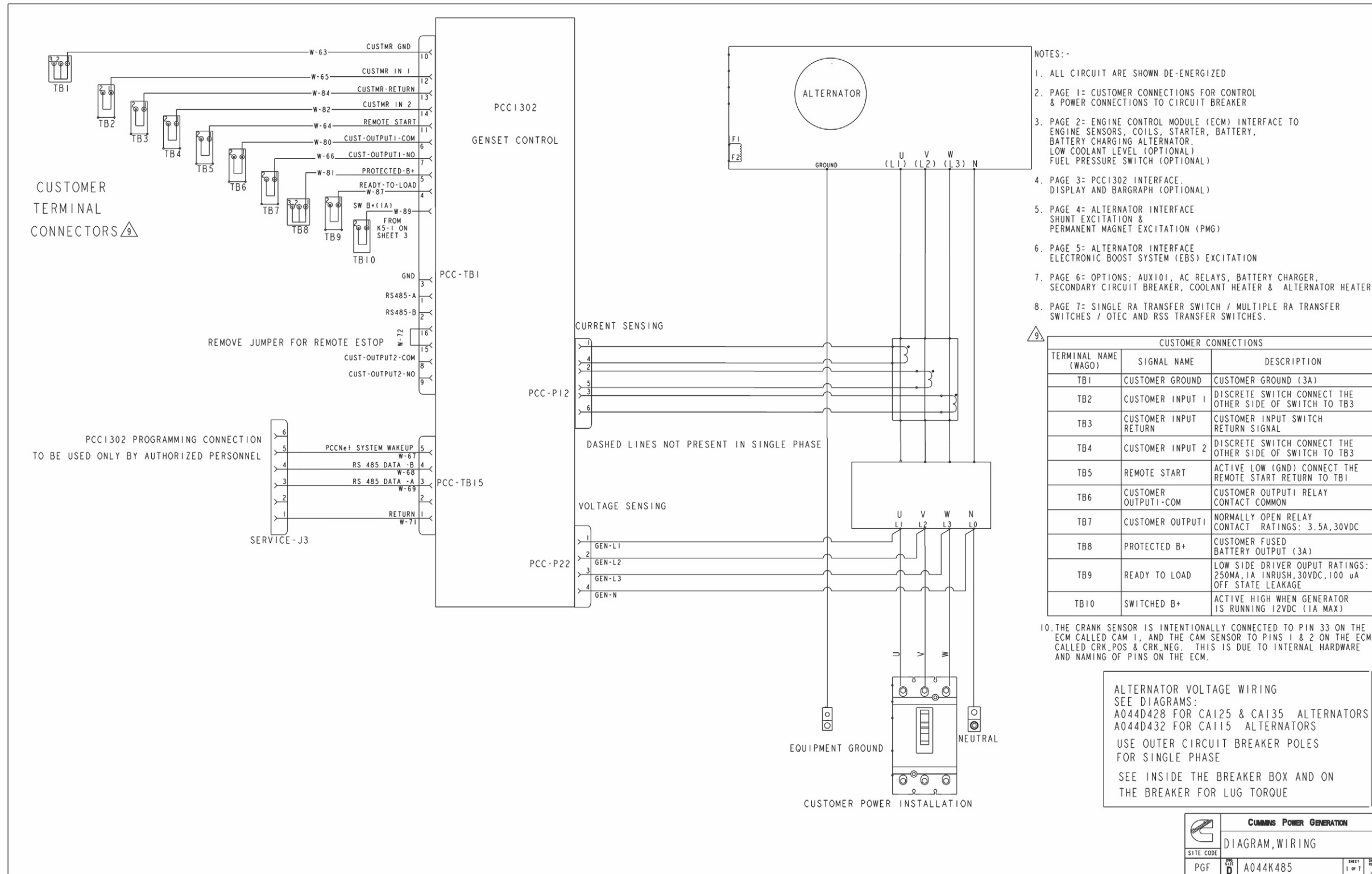

FIGURE 39. WIRING DIAGRAM (SHEET 1 OF 7)

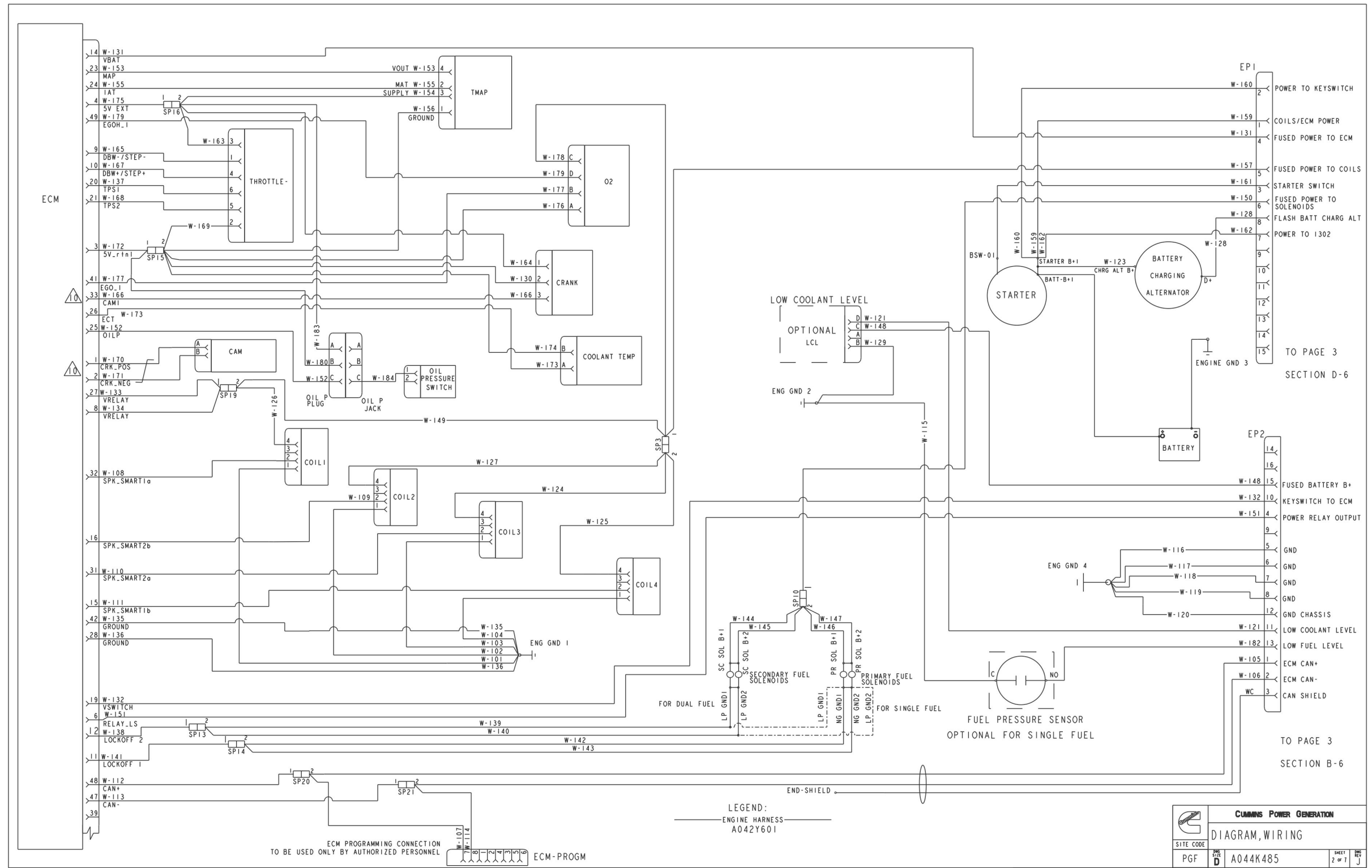

FIGURE 40. WIRING DIAGRAM (SHEET 2 OF 7)

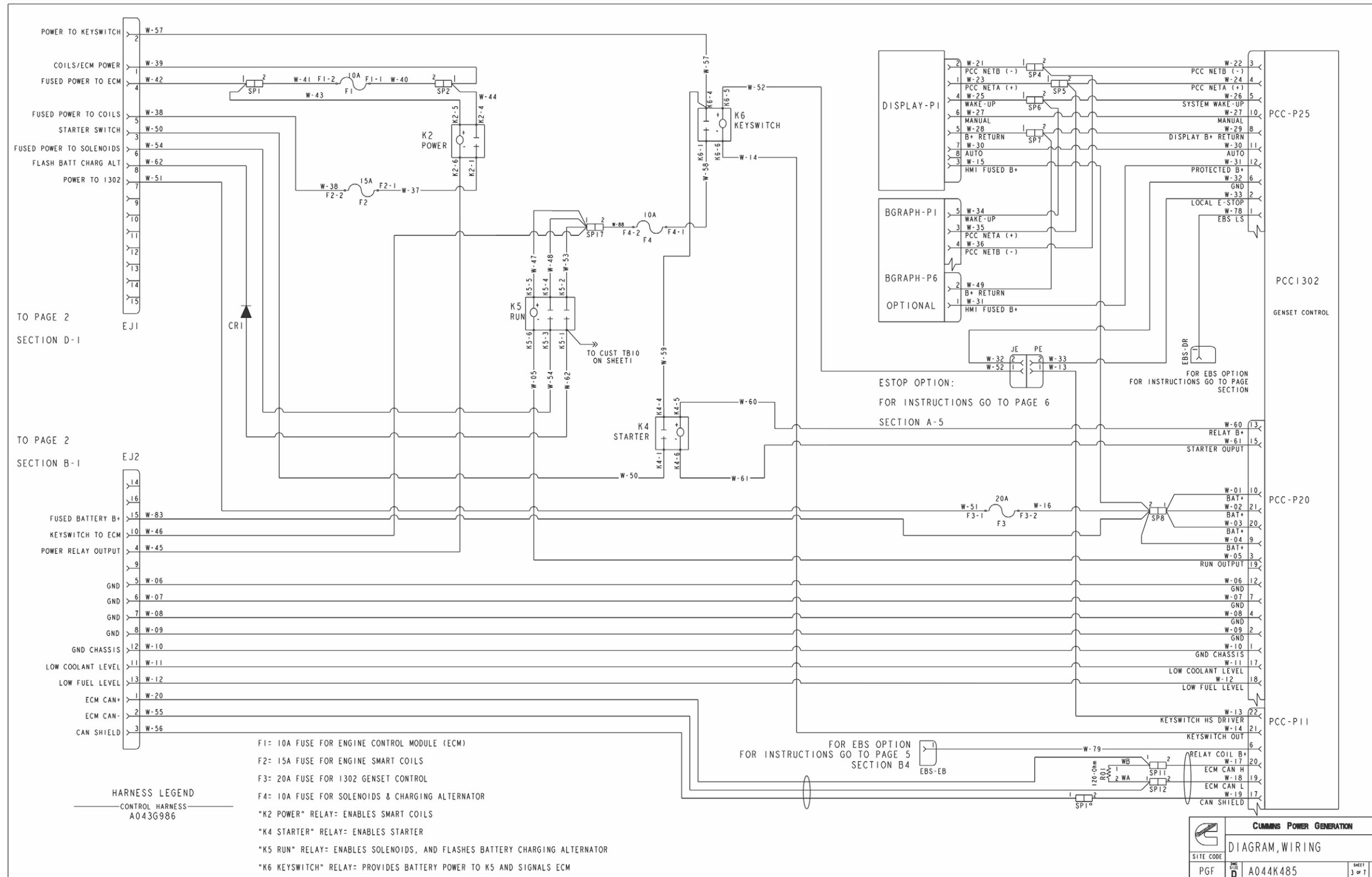
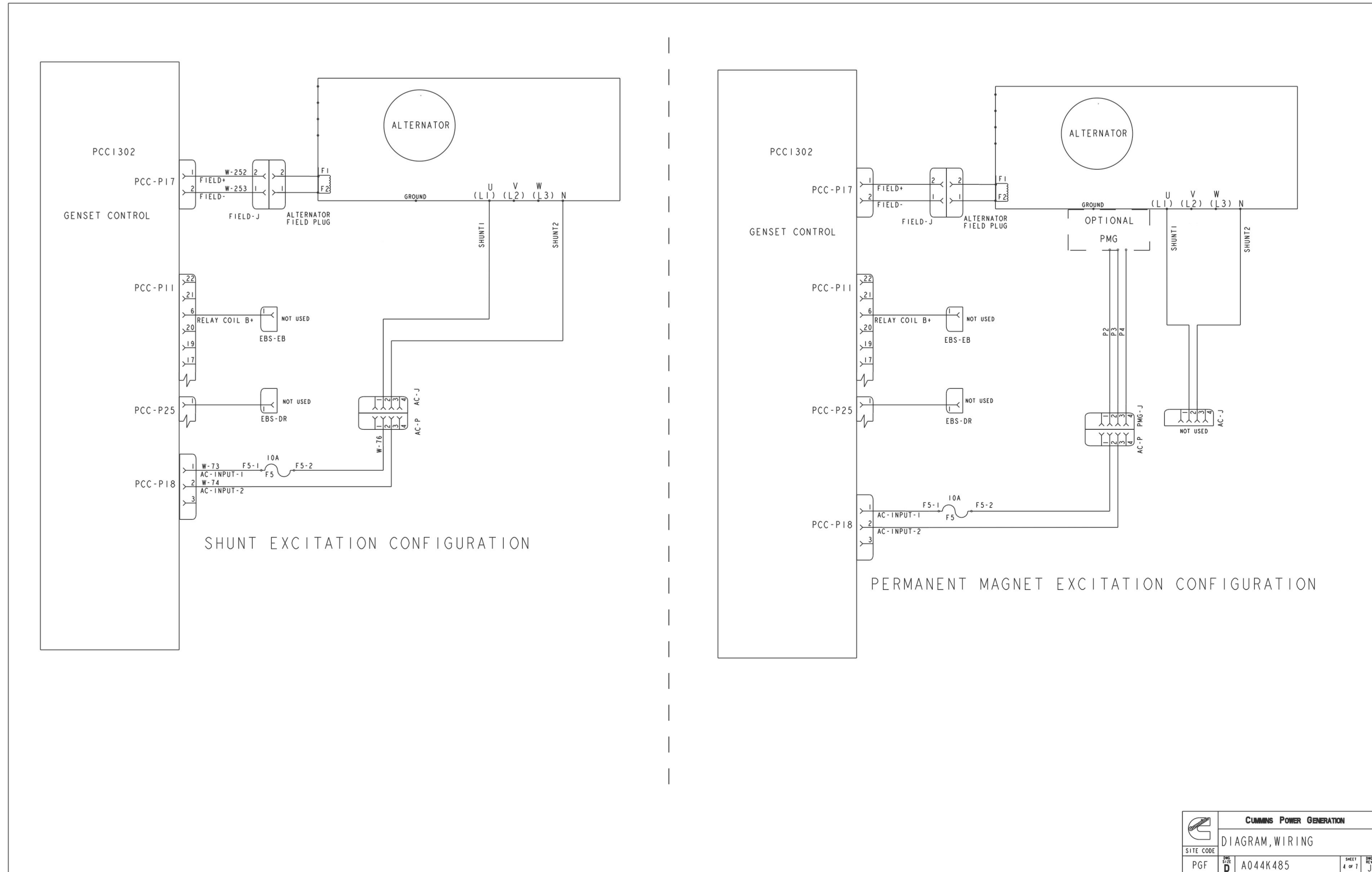

FIGURE 41. WIRING DIAGRAM (SHEET 3 OF 7)



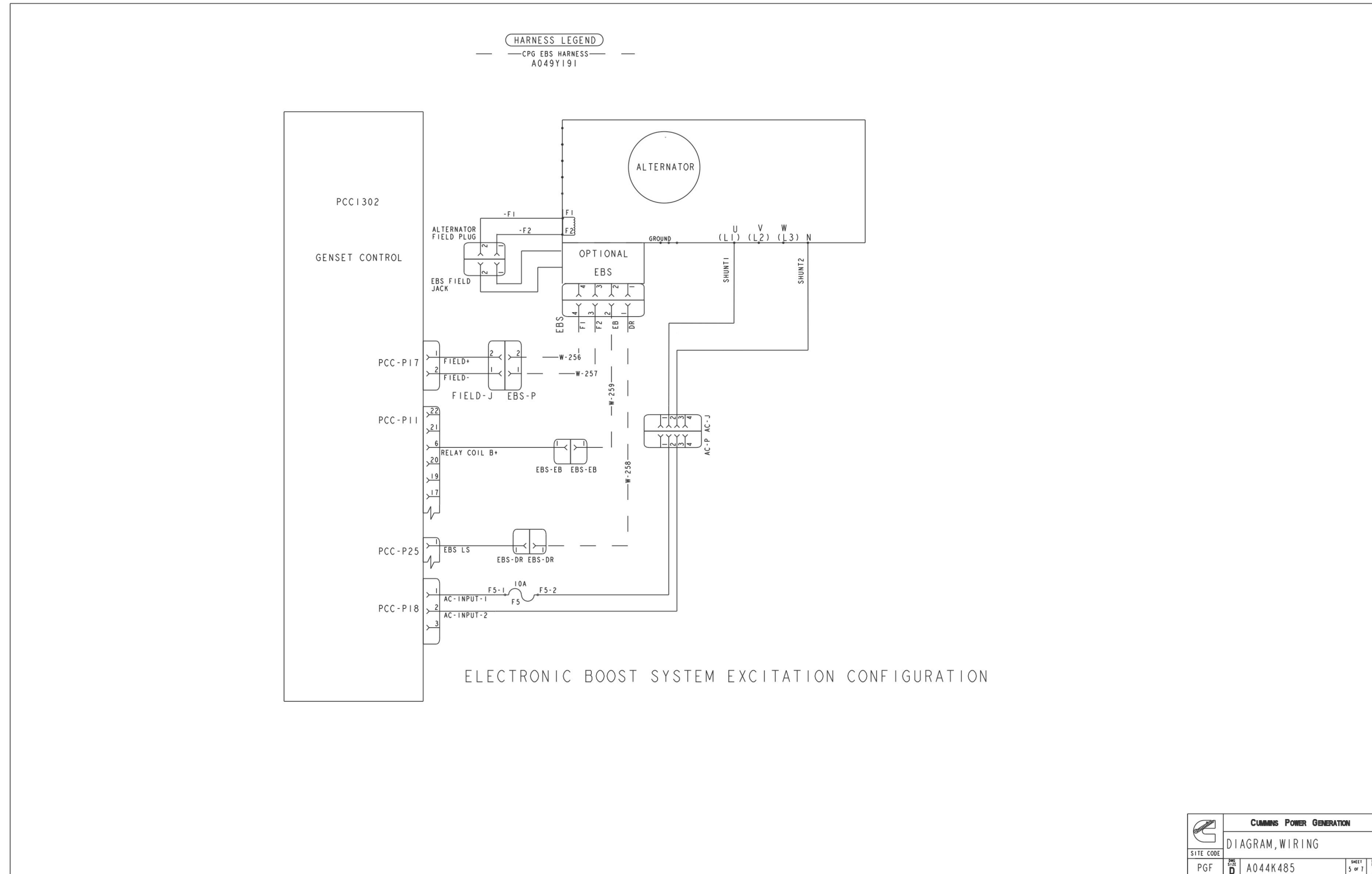

FIGURE 43. WIRING DIAGRAM (SHEET 5 OF 7)

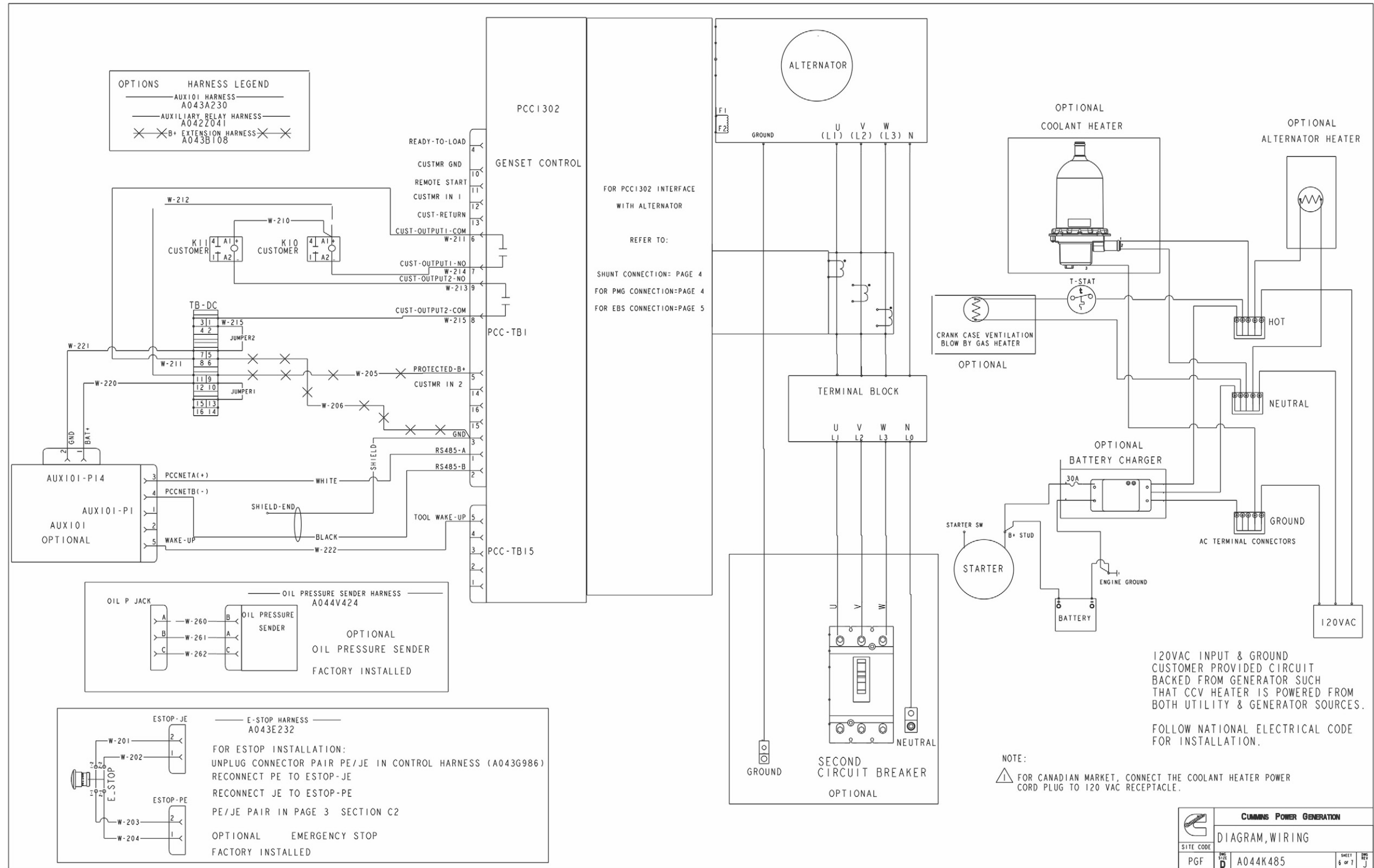

FIGURE 44. WIRING DIAGRAM (SHEET 6 OF 7)

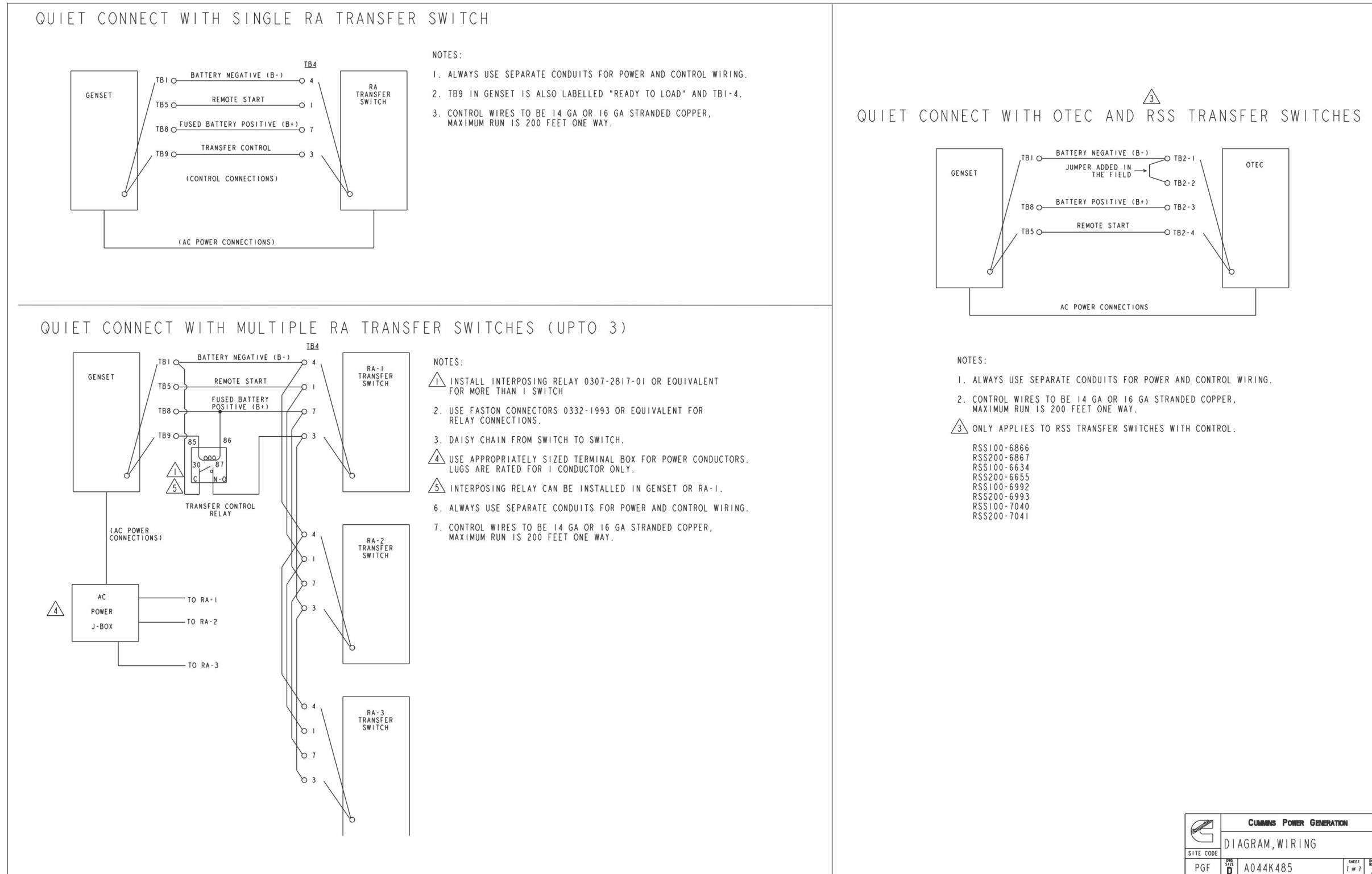

FIGURE 45. WIRING DIAGRAM (SHEET 7 OF 7)

This page is intentionally blank.

Appendix D. Seismic Requirements

Table of Contents

Figure 46. Seismic Installation Specifications	113
Figure 47. Seismic Installation Specifications	114
Figure 48. Seismic Installation Notes	115
Figure 49. Seismic Installation Requirements	116
Figure 50. Seismic Installation Requirements	117
Figure 51. Seismic Installation Requirements	118
Figure 52. Seismic Installation Requirements	119

The drawings included in this section are representative. For current complete information, refer to the drawing package that was shipped with the unit.

D.1 Seismic Installation Instructions (A044H911)

GRADE MOUNTED GENERATOR SETS									
CUMMINS GENSET MODEL	CONFIGURATION	ATTACHMENT TO STEEL		ATTACHMENT TO CONCRETE					
		EVALUATION PARAMETERS	STEEL BOLTS	EVALUATION PARAMETERS	CONCRETE ANCHORS	ANCHOR EMBEDMENT	ANCHOR SPACING	DISTANCE TO NEAREST EDGE	CONCRETE SLAB THICKNESS
C20 N6 C22 N6 C25 N6 C30 N6 C36 N6 C40 N6 C30 N6H C36 N6H C40 N6H C45 N6H C50 N6H C60 N6H	GENERATOR SET WITH OR WITHOUT ENCLOSURE	CBC 2013/IBC 2012 S _{ds} ≤ 2.5 I _p ≤ 1.5 a _p /R _p ≤ 2.5/2.0 z/h = 0	(QTY 4) 5/8" DIAMETER ASTM 307 BOLTS WITH WASHER THROUGH THE BASE RAIL MOUNTING HOLES.	CBC 2013/IBC 2012 S _{ds} ≤ 2.5 I _p ≤ 1.5 a _p /R _p ≤ 2.5/2.0 z/h = 0 Ω = 2.5	(QTY 4) 5/8" DIAMETER HILTI KB-TZ EXPANSION ANCHORS (ICC-ESR-1917) WITH WASHERS THROUGH BASE RAIL MOUNTING HOLES.	3-1/8" MINIMUM	4-3/4" MINIMUM	6" MINIMUM	5" MINIMUM

ROOF MOUNTED GENERATOR SETS			
CUMMINS GENSET MODEL	CONFIGURATION	ATTACHMENT TO STEEL	
		EVALUATION PARAMETERS	STEEL BOLTS
C20 N6 C22 N6 C25 N6 C30 N6 C36 N6 C40 N6 C30 N6H C36 N6H C40 N6H C45 N6H C50 N6H C60 N6H	GENERATOR SET WITH OR WITHOUT ENCLOSURE	CBC 2013/IBC 2012 S _{ds} ≤ 2.5 I _p ≤ 1.5 a _p /R _p ≤ 2.5/2.0 z/h ≤ 1	(QTY 4) 5/8" DIAMETER ASTM 307 BOLTS WITH WASHERS THROUGH THE BASE RAIL MOUNTING HOLES.

CUMMINS POWER GENERATION			
INSTALLATION, GENSET			
SEISMIC REQUIREMENTS			
SITE CODE	REV	DATE	BY
PGF	D	A044H911	2 of 1 G

FIGURE 46. SEISMIC INSTALLATION SPECIFICATIONS

GRADE MOUNTED GENERATOR SETS									
CUMMINS GENSET MODEL	CONFIGURATION	ATTACHMENT TO STEEL		ATTACHMENT TO CONCRETE					
		EVALUATION PARAMETERS	STEEL BOLTS	EVALUATION PARAMETERS	CONCRETE ANCHORS	ANCHOR EMBEDMENT	ANCHOR SPACING	DISTANCE TO NEAREST EDGE	CONCRETE SLAB THICKNESS
C10 D6 C15 D6 C20 D6 C25 D6 C30 D6 C35 D6 C40 D6 C50 D6 C60 D6	GENERATOR SET WITH OR WITHOUT ENCLOSURE NO FUEL TANK	CBC 2013/IBC 2012 Sds <= 2.5 Ip <= 1.5 ap/Rp <= 2.5/2.0 z/h = 0	(QTY 4) 5/8" DIAMETER ASTM A490 BOLTS WITH WASHERS THROUGH BASE RAIL MOUNTING HOLES.	CBC 2013/IBC 2012 Sds <= 2.5 Ip <= 1.5 ap/Rp <= 2.5/2.0 z/h = 0 Ω = 2.5	(QTY 4) 5/8" DIAMETER HILTI KB-TZ EXPANSION ANCHORS (ICC-ESR-1917) WITH WASHERS THROUGH BASE RAIL MOUNTING HOLES.	4" MINIMUM	4.25" MINIMUM	6" MINIMUM	6" MINIMUM

ROOF MOUNTED GENERATOR SETS				
CUMMINS GENSET MODEL	CONFIGURATION	ATTACHMENT TO STEEL		
		EVALUATION PARAMETERS		STEEL BOLTS
C10 D6 C15 D6 C20 D6 C25 D6 C30 D6 C35 D6 C40 D6 C50 D6 C60 D6	GENERATOR SET WITH OR WITHOUT ENCLOSURE, WITH FUEL TANK. FUEL TANKS: A045T328, A045T334, A045T336, A045T330, A045T332, A045D209	GRADE MOUNTED CBC 2013/IBC 2012 Sds <= 2.5 Ip <= 1.5 ap/Rp <= 2.5/2.0 z/h = 0	ROOF MOUNTED CBC 2013/IBC 2012 Sds <= 2.0 Ip <= 1.5 ap/Rp <= 2.5/2.0 z/h <= 1	(QTY 4) 5/8" DIAMETER ASTM A490 BOLTS WITH WASHERS THROUGH BASE RAIL MOUNTING HOLES OR FUEL TANK MOUNTING HOLES
C25 D6 C30 D6 C35 D6 C40 D6 C50 D6 C60 D6	GENERATOR SET WITH OR WITHOUT ENCLOSURE, WITH FUEL TANK. FUEL TANKS: A045T340, A045T342, A045T344, A046U786, A046U828	GRADE MOUNTED CBC 2013/IBC 2012 Sds <= 2.5 Ip <= 1.5 ap/Rp <= 2.5/2.0 z/h = 0	ROOF MOUNTED CBC 2013/IBC 2012 Sds <= 2.0 Ip <= 1.5 ap/Rp <= 2.5/2.0 z/h <= 1	(QTY 6) 5/8" DIAMETER ASTM A490 BOLTS WITH WASHERS THROUGH BASE RAIL MOUNTING HOLES OR FUEL TANK MOUNTING HOLES

CUMMINS POWER GENERATION			
INSTALLATION, GENSET			
SEISMIC REQUIREMENTS			
SITE CODE	REV	DATE	SHEET
PGF	D	A044H911	3 of 7

FIGURE 47. SEISMIC INSTALLATION SPECIFICATIONS

SEISMIC INSTALLATIONS NOTES:

1. THE DESIGN OF POST-INSTALLED ANCHORS IN CONCRETE USED FOR THE COMPONENT ANCHORAGE IS PRE-QUALIFIED FOR SEISMIC APPLICATIONS IN ACCORDANCE WITH "ACI 308-11" AND DOCUMENTED IN A REPORT BY A REPUTABLE TESTING AGENCY. (EX. THE EVALUATION SERVICE REPORT ISSUED BY THE INTERNATIONAL CODE COUNCIL)
2. ANCHORS MUST BE INSTALLED TO AN EMBEDMENT DEPTH AS RECOMMENDED IN THE PRE-QUALIFICATION TEST REPORT AS DEFINED IN NOTE 1. FOR "CBC 2013" APPLICATIONS.
3. ANCHORS MUST BE INSTALLED IN MINIMUM 3000 PSI COMPRESSIVE STRENGTH NORMAL WEIGHT STRUCTURAL CONCRETE. CONCRETE AGGREGATE MUST COMPLY WITH "ASTM C33".
4. ANCHORS MUST BE INSTALLED TO THE TORQUE SPECIFICATION AS RECOMMENDED BY THE ANCHOR MANUFACTURER.
5. ANCHORS MUST BE INSTALLED IN LOCATIONS SPECIFIED ON THIS INSTALLATION DRAWING.
6. WASHERS MUST BE INSTALLED AT EACH ANCHOR LOCATION BETWEEN THE ANCHOR HEAD AND EQUIPMENT FOR TENSION LOAD DISTRIBUTION. WASHERS MUST BE TYPE A OR B PLAIN WASHERS MEETING ASME B18.21.1-2009. WASHER SIZE TO MATCH ANCHOR DIAMETER.
7. CONCRETE FLOOR SLAB AND CONCRETE HOUSEKEEPING PADS MUST BE DESIGNED AND REBAR REINFORCED FOR SEISMIC APPLICATIONS IN ACCORDANCE WITH "ACI 318-11".
8. ALL HOUSEKEEPING PAD THICKNESSES MUST BE DESIGNED IN ACCORDANCE WITH THE PRE-QUALIFICATION TEST REPORT AS DEFINED IN NOTE 1 OR A MINIMUM OF 1.5X THE ANCHOR EMBEDMENT DEPTH, WHICHEVER IS LARGEST (UNLESS NOTED OTHERWISE).
9. ALL HOUSEKEEPING PADS MUST BE DOWELLED OR CAST INTO THE BUILDING STRUCTURAL FLOOR SLAB AND DESIGNED FOR SEISMIC APPLICATION PER "ACI 318-11" AND AS APPROVED BY THE STRUCTURAL ENGINEER OF RECORD.
10. (NOTE REMOVED)
11. FLOOR MOUNTED EQUIPMENT (WITH OR WITHOUT A HOUSEKEEPING PAD) MUST BE INSTALLED TO A STEEL REINFORCED STRUCTURAL CONCRETE FLOOR THAT IS SEISMICALLY DESIGNED AND APPROVED BY THE ENGINEER OF RECORD TO RESIST ALL LOADS FROM EQUIPMENT BEING ANCHORED TO THE FLOOR.
12. COORDINATE REINFORCEMENT OF SUPPORT STRUCTURE WITH EQUIPMENT ANCHOR LOCATIONS.
13. ATTACHING SEISMIC CERTIFIED EQUIPMENT TO FLOOR OTHER THAN THOSE DESIGNED TO ACCEPT THE SEISMIC LOADS FROM CERTIFIED EQUIPMENT BY THE STRUCTURAL ENGINEER OF RECORD IS PROHIBITED.
14. (NOTE REMOVED)
15. (NOTE REMOVED)
16. INSTALLATION ONTO A STEEL ROOF STRUCTURE OR MANUFACTURED STEEL CURB SHALL BE COORDINATED WITH THE STRUCTURAL ENGINEER OF RECORD.
17. (NOTE REMOVED)
18. CONNECTIONS TO THE EQUIPMENT, INCLUDING BUT NOT LIMITED TO CONDUIT, WIRING FROM CABLE TRAYS, OTHER ELECTRICAL SERVICES OR OTHER CONNECTIONS, ARE THE RESPONSIBILITY OF THE INSTALLING CONTRACTOR AND BEYOND THE SCOPE OF THIS DOCUMENT. FLEXIBLE ATTACHMENTS MUST BE USED FOR SEISMIC CONNECTIONS TO ISOLATED COMPONENTS OR ISOLATED EQUIPMENT. THE FLEXIBLE ATTACHMENT MUST PROVIDE FOR ENOUGH RELATIVE DISPLACEMENT TO REMAIN CONNECTED TO THE EQUIPMENT AND FUNCTIONAL DURING AND AFTER A SEISMIC EVENT.

 CUMMINS POWER GENERATION			
INSTALLATION, GENSET			
SEISMIC REQUIREMENTS			
SITE CODE	REV	REV	SHEET
PGF	D	A044H911	1 OF 1 G

FIGURE 48. SEISMIC INSTALLATION NOTES

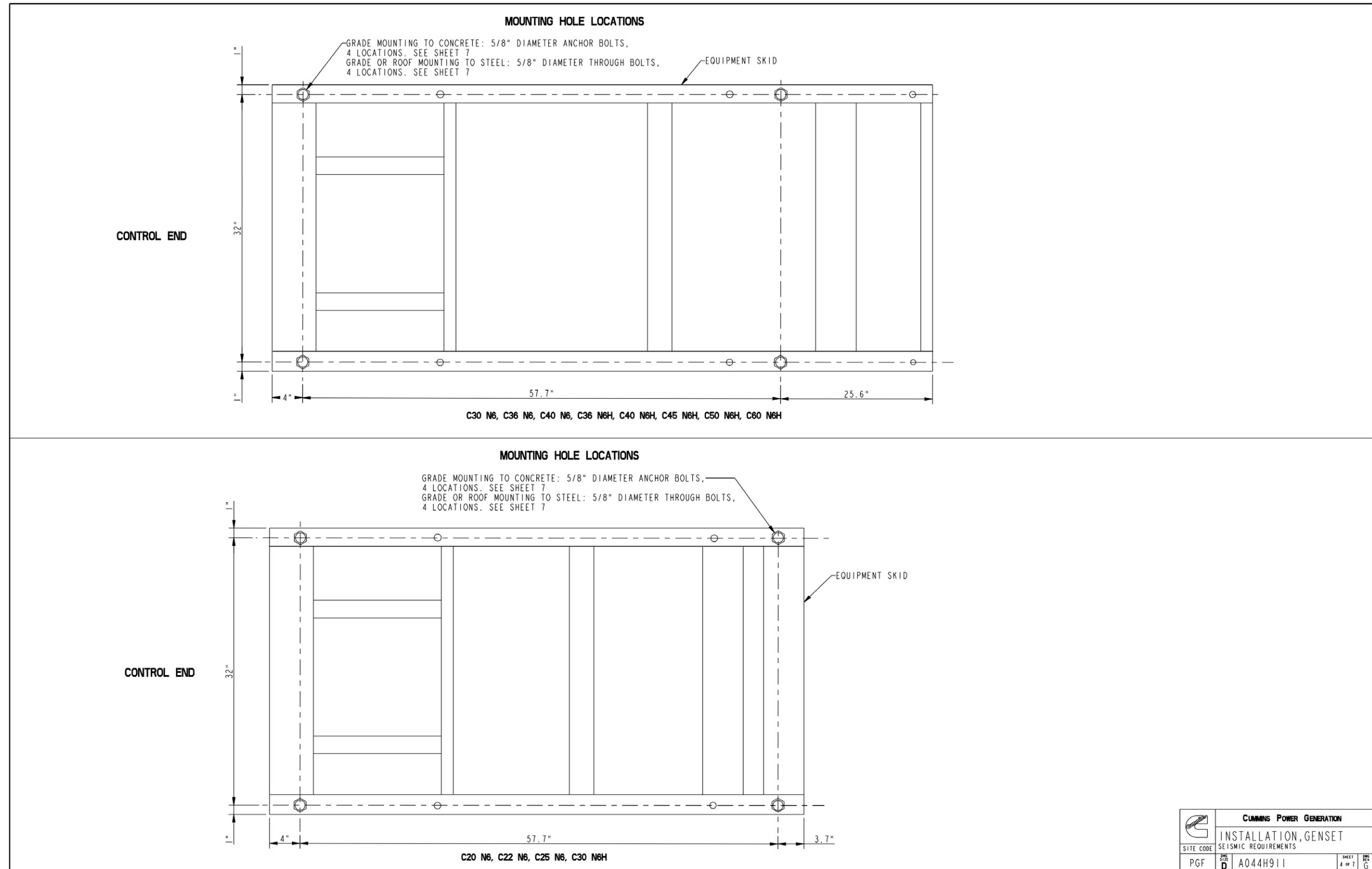

FIGURE 49. SEISMIC INSTALLATION REQUIREMENTS

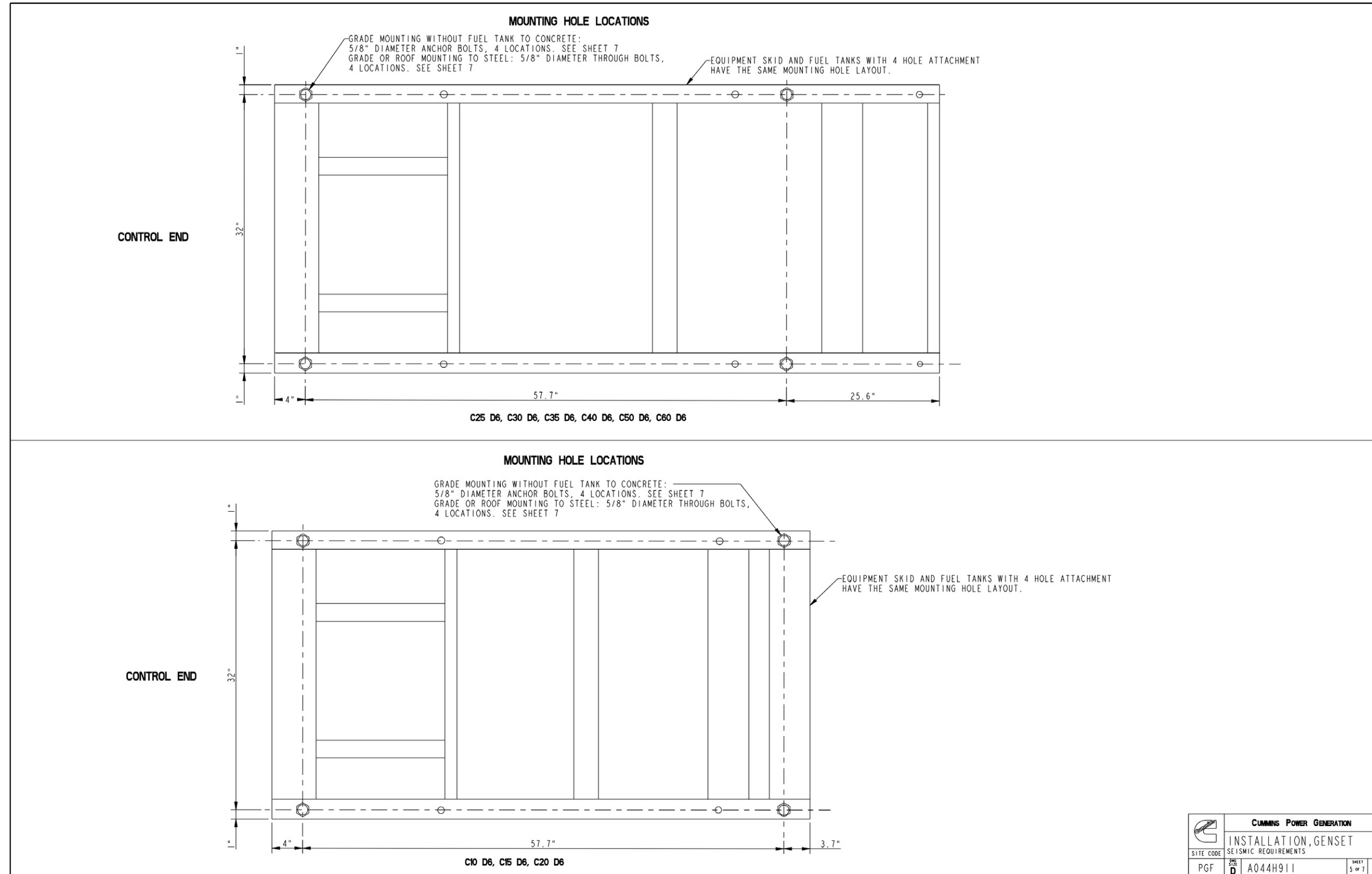

FIGURE 50. SEISMIC INSTALLATION REQUIREMENTS

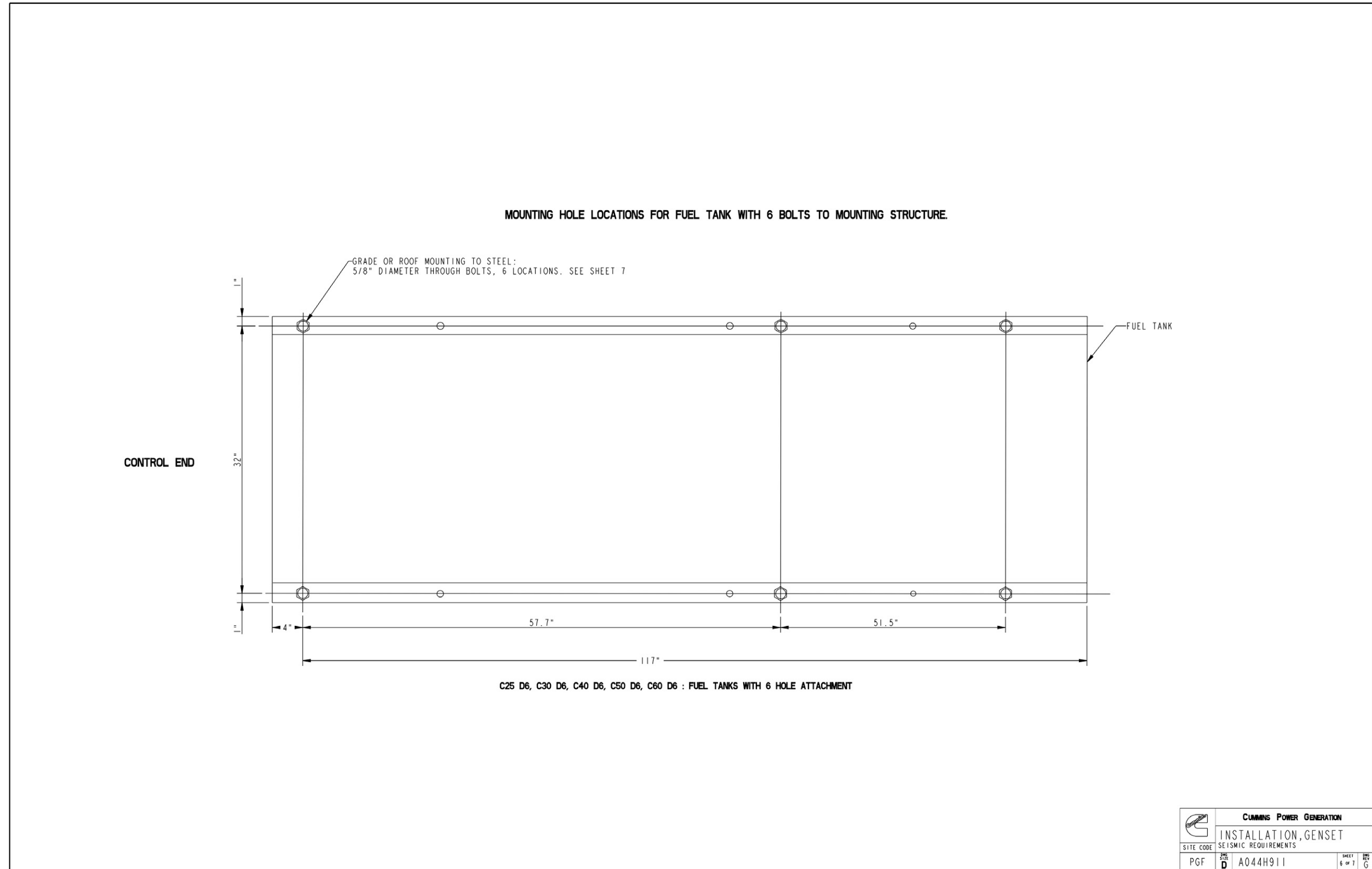

FIGURE 51. SEISMIC INSTALLATION REQUIREMENTS

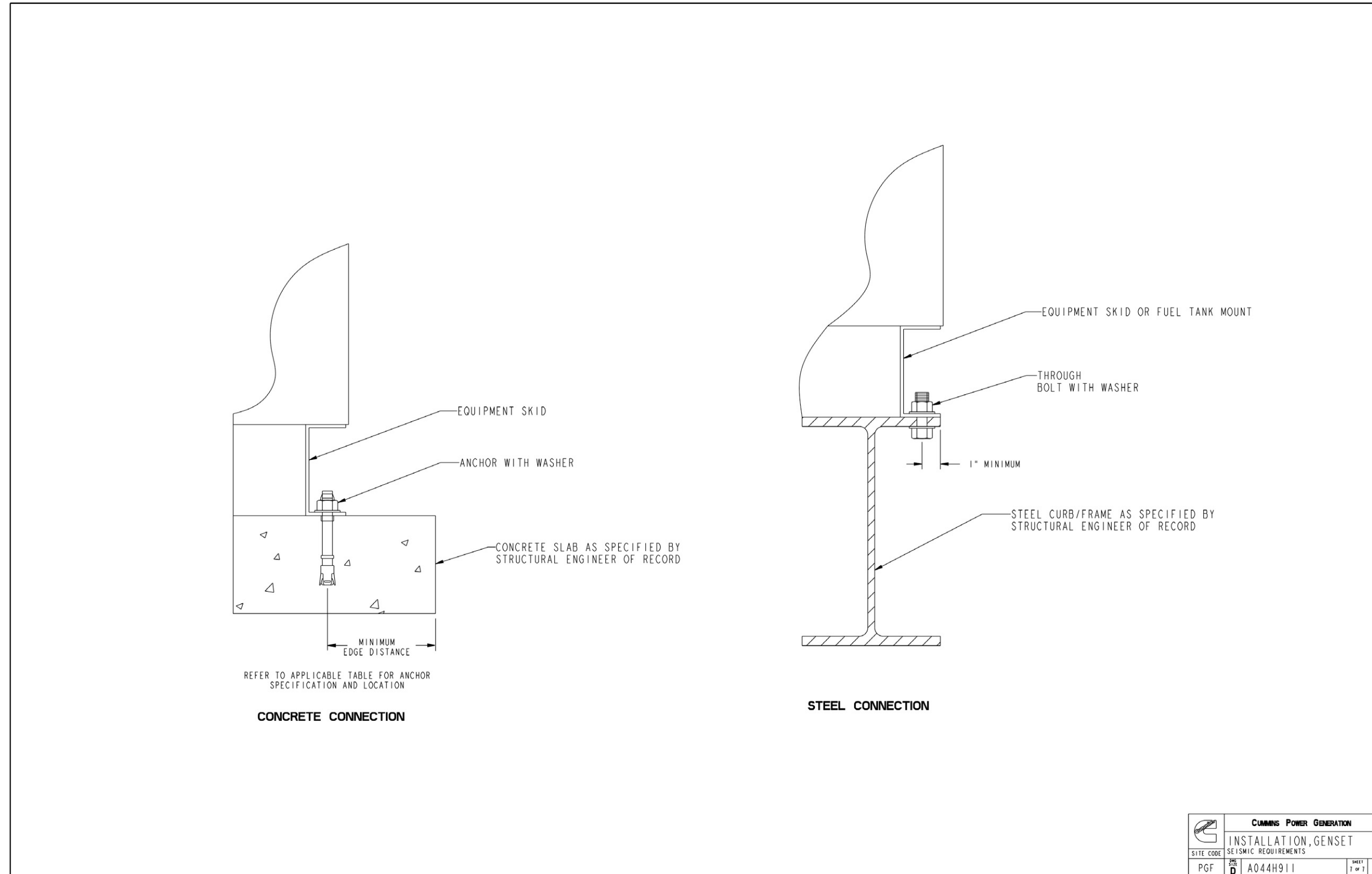

FIGURE 52. SEISMIC INSTALLATION REQUIREMENTS

This page is intentionally blank.

power.cummins.com

Copyright © 2018 Cummins Inc. All rights reserved.

Cummins, the "C" logo, PowerCommand, AmpSentry, and InPower are trademarks of Cummins Inc.

Other company, product, or service names may be trademarks or service marks of others.

Specifications are subject to change without notice.

