

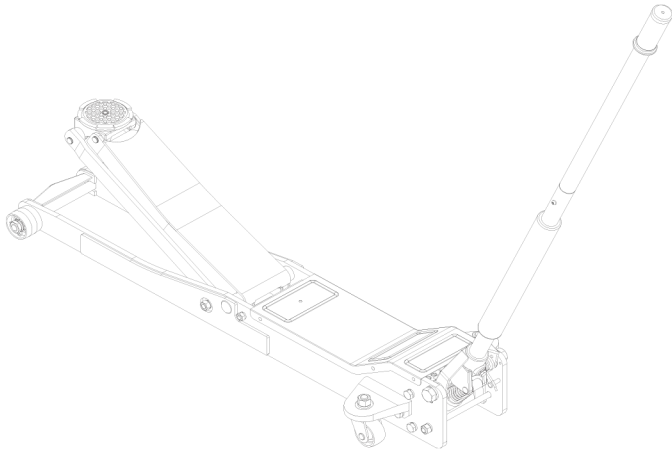

DOMINATOR LOW PROFILE SERVICE JACK

SKU
35-9775

CAPACITY
1.5 TON



U.S. Patent No's. 6,199,379 • 5,946,912



This is the safety alert symbol. It is used to alert you to potential personal injury hazards. Obey all safety messages that follow this symbol to avoid possible injury or death.

⚠ WARNING



*To avoid crushing and related injuries:
NEVER work on, under or around a
load supported only by a hydraulic
jack. ALWAYS use an identical pair of
adequately rated jack stands.*

- ⚠ **WARNING:** Cancer and Reproductive Harm.
- ⚠ **AVERTISSEMENT:** Cancer et dommages au système reproducteur.
- ⚠ **ADVERTENCIA:** Cáncer y daño reproductivo.

www.P65Warnings.ca.gov

SFA Companies

<http://www.omegalift.com>

Read this manual and follow all the Safety Rules and Operating Instructions before using this product.

29013E-M0_022020

SAFETY AND GENERAL INFORMATION

Save these instructions. For your safety, read, understand, and follow the information provided with and on this device before using. The owner and/or operator shall have an understanding of the device, its operating characteristics and safety operating instructions before operating the equipment. The owner and/or operator shall be aware that use and repair of this product may require special skills and knowledge. Instructions and safety information shall be read to and discussed with the operator in the operator's native language, making sure that the operator comprehends their contents, before use of this equipment is authorized. If any doubt exists as to the safe and proper use of this device, remove from service immediately.

Inspect before each use. Do not use if abnormal conditions such as cracked welds, damaged, loose or missing parts are noted. Any equipment that appears damaged in any way, is found to be worn, or operates abnormally shall be removed from service until repaired. If the equipment has been or is suspected to have been subjected to an abnormal load or shock, immediately discontinue use until inspected by a factory authorized repair facility (contact distributor or manufacturer for list of authorized repair facilities). It is recommended that an annual inspection be made by an authorized repair facility. Labels and Operator's Manuals are available from the manufacturer.

PRODUCT DESCRIPTION

This Hydraulic Service Jack is designed to lift, but not support, one end of a vehicle. Immediately after lifting, loads must be supported by an identical pair of appropriately rated jack stands. MagicLift™ service jacks have a unique feature that provides fast, no load lifts to the jacking point, at which time it lifts in approximately 1/4" ~ 3/4" increments.

⚠ WARNING: *Never use a hydraulic jack as a stand-alone device. After lifting, immediately support the lifted vehicle with an identical pair of appropriately rated jack stands.*

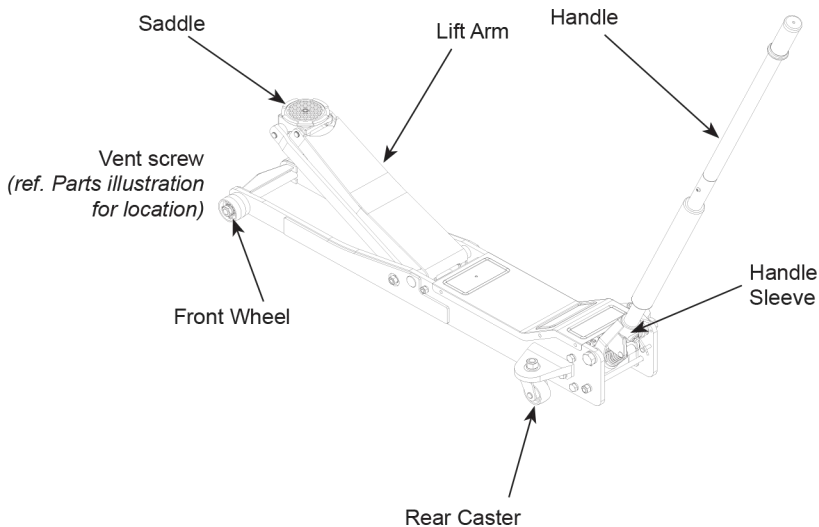

Figure 1 - Service Jack Nomenclature

⚠️ WARNING

- Study, understand, and follow all instructions before operating this device.
- Do not exceed rated capacity.
- Use only on hard, level surface capable of supporting the load.
- Lifting device only. Immediately after lifting, support the vehicle with appropriate means.
- Do not move or dolly the vehicle while on the jack.
- Lift only on areas of the vehicle as specified by the vehicle manufacturer.
- No alterations shall be made to this product.
- Failure to heed these markings may result in personal injury and/or property damage.

⚠️ WARNING



To avoid crushing and related injuries:

- Never work on, under or around a load supported only by hydraulic jack.
- Always use an identical pair of adequately rated jack stands.
- Chock each unlifted tire in both directions.
- Do not use this device to lift, level, lower, support nor move a house, mobile home, travel trailer, camper or any building structure.
- Be alert and sober when using this product. Do not operate under the influence of drugs or alcohol.

SPECIFICATIONS

Model	Capacity	Jack Size (L x W x H)	Min. Height	Max. Height
37-9775	1-1/2 Ton	49-1/2" x 15-3/4" x 7-1/4"	2-1/2"	19-7/8"

PREPARATION

Assembly

1. Assemble the two-piece handle with provided bolt.
2. Insert handle into the handle fork. Tighten the bolt on handle fork to prevent accidental removal of handle while in use.

⚠️ WARNING: Do not lift or carry jack by handle. Handle could dislodge and jack fall, resulting in possible injury or property damage.

Before Use

1. Verify that the product and application are compatible, if in doubt call Omega Tech Service (888) 332-6419.
2. Before using this product, read the operator's manual completely and familiarize yourself thoroughly with the product, its components and recognize the hazards associated with its use.
3. To familiarize yourself with basic operation, locate and turn the release valve (handle):
 - a. *Clockwise* until firm resistance is felt to further turning. This is the '**CLOSED**' release valve position used to raise the saddle.
 - b. *Counter-clockwise*, but no more than 1/2 turn from the closed position. This is the '**OPEN**' release valve position used to lower the saddle.
4. With saddle fully lowered, and release valve closed, pump the operating handle. If lift arm responds immediately, jack is ready for use. If jack does not respond, follow **Bleeding/Venting Trapped Air** procedure below.
5. Ensure that jack rolls freely. Raise and lower the unloaded saddle throughout the lifting range before putting into service to ensure the pump operates smoothly. Replace worn or damaged parts and assemblies with Omega authorized replacement parts only.

Bleeding/Venting Trapped Air

With the Release Valve in the OPEN position (3b above) and Saddle fully lowered, locate and remove the Oil Filler Plug/Screw. Pump Handle 6 to 8 full strokes. This will help release any pressurized air which may be trapped within the reservoir. Check oil level and reinstall Oil Filler Plug/Screw.

OPERATION

Lifting

1. Follow the vehicle manufacturer's recommended guidelines for lifting. Engage the emergency brake and chock each unlifted wheel in both directions to prevent inadvertent vehicle movement.
2. Close the release valve by turning the handle clockwise until firm resistance is felt.
3. Refer to the vehicle manufacturer owner's manual to locate approved lifting points on the vehicle. Center jack saddle under lift point.
4. Pump handle to contact lift point. To lift, continue pumping until load reaches desired height.
5. Transfer the load **immediately** to an identical pair of appropriately rated jack stands.

Lowering

 **WARNING:** Clear all tools and personnel before lowering load. Open release valve slowly. The further handle is turned counter-clockwise, the faster the load will descend. Maintain control of the load at all times.

1. Raise load high enough to clear jack stands.
2. Remove jack stands.
3. Slowly turn the handle counter-clockwise, but no more than 1/2 full turn.
If the load fails to lower:
 - a. Use a functioning jack to raise the vehicle high enough to reinstall jack stands.
 - b. Remove the malfunctioning jack and then the jack stands.
 - c. Use the functioning jack to lower the vehicle.
4. After removing jack from under the vehicle, lower lifting arm completely to reduce ram exposure to rust and contamination.

MAINTENANCE

NOTICE: Use only good quality hydraulic jack oil. Avoid mixing different types of fluid and NEVER use brake fluid, turbine oil, transmission fluid, motor oil or glycerin. Improper fluid can cause premature failure of the jack and the potential for sudden and immediate loss of load. Premium hydraulic jack oil is recommended.

Adding oil

1. With saddle fully lowered set jack in its upright, level position. Remove vent screw.
2. Fill with oil until ~3/16" above the inner cylinder as seen from the oil filler hole. Reinstall vent screw.

Changing oil

For best performance and longest life, replace the complete fluid supply at least once per year.

1. With saddle fully lowered, remove vent screw.
2. Lay the jack on its side and drain the fluid into a suitable container.

NOTICE: Dispose of hydraulic fluid in accordance with local environmental regulations.

3. Fill with oil until ~3/16" above the inner cylinder as seen from the oil filler hole. Reinstall vent screw.

Lubrication

A periodic coating of light lubricating oil to pivot points, axles and hinges will help to prevent rust and assure that wheels, casters and pump assemblies move freely. Lubricate lift arm through grease fittings.

Cleaning

Check the pump piston and ram for signs of rust or corrosion. Clean as needed and wipe with an oily cloth.

NOTICE: Do not use sandpaper or abrasive material on ram and pump piston surfaces.

Storage

When not in use, store the jack with saddle fully lowered.

TROUBLESHOOTING

Symptom	Possible Causes	Corrective Action
Jack will not lift load	<ul style="list-style-type: none">• Release valve not tightly closed• Load is too heavy	<ul style="list-style-type: none">• Ensure release valve tightly closed• Consider higher capacity jack
Jack will lift, but not maintain pressure	<ul style="list-style-type: none">• Release valve not tightly closed• Hydraulic unit malfunction	<ul style="list-style-type: none">• Ensure release valve tightly closed• Discontinue use, contact Omega Technical Service
Jack will not lower after unloading	<ul style="list-style-type: none">• Reservoir overfilled• Linkages binding	<ul style="list-style-type: none">• Drain fluid to proper level• Clean and lubricate moving parts• Inspect for damage. If found, discontinue use and contact Omega Technical Service
Poor lift performance	<ul style="list-style-type: none">• Fluid level low• Hydraulic unit malfunction	<ul style="list-style-type: none">• Ensure proper fluid level• Discontinue use, contact Omega Technical Service
Will not lift to full extension	<ul style="list-style-type: none">• Fluid level low	<ul style="list-style-type: none">• Ensure proper fluid level

REPLACEMENT PARTS

Not all components of the jack are replacement items, but are illustrated as a convenient reference of location and position in the assembly sequence. When ordering parts, give Model number, serial number and parts description. Call or write for current pricing: SFA Companies, 10939 N. Pomona Ave. Kansas City, MO 64153, USA. Tel: (888) 332-6419; Fax: (816) 891-6599; e-mail: sales@omegalift.com; Website: <http://www.omegalift.com>

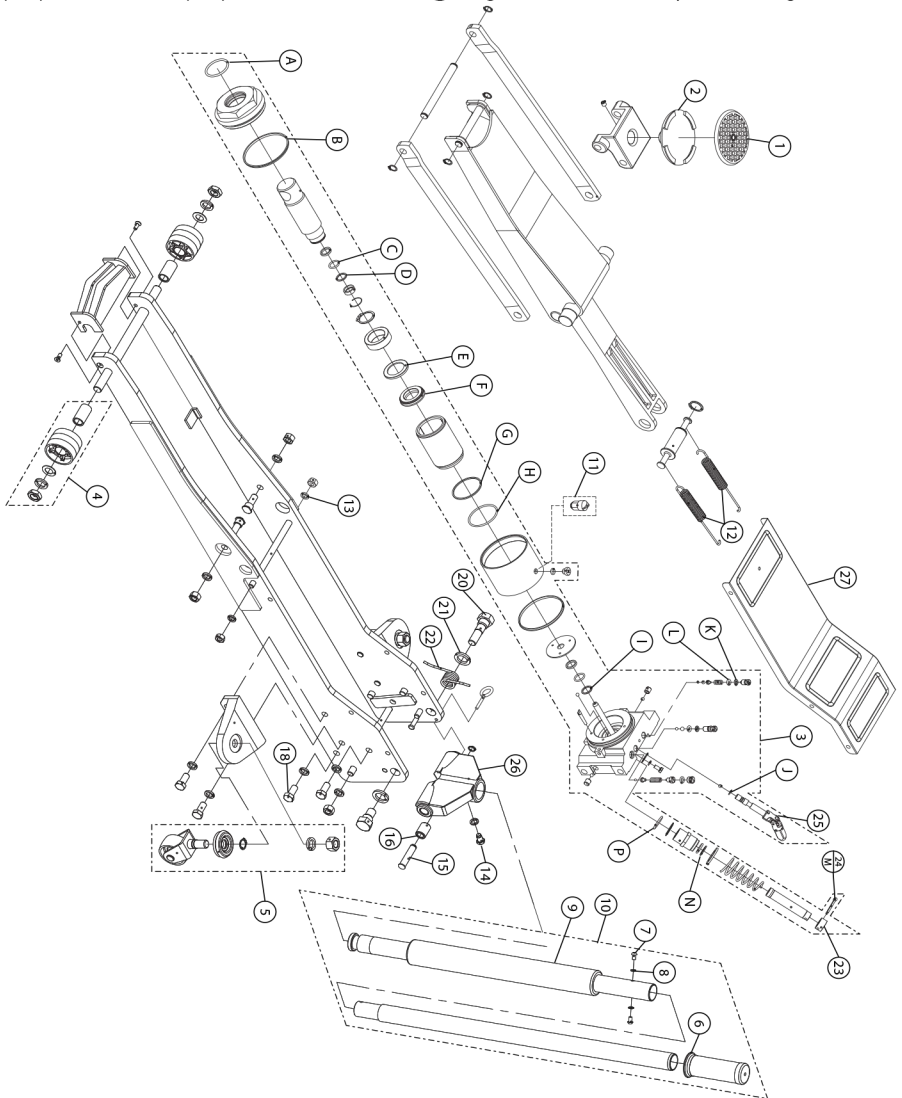

Figure 2 - Replacement Parts Illustration for Model 29013E

Replacement Parts for Model 29013E

Item	Part No.	Description	Qty
1	K500-50001-0440	Saddle Pad	1
2	G862-10001-0000	Saddle	1
3	G8620S-K01	Hydraulic Unit	1
4	G8620S-K02	Front Wheel Assembly	2
5	G8620S-K03	Rear Caster Assembly	2
6	G863-00001-0010	Handle Grip	1
7	G595-40006-0410	Socket Head Screw	2
8	1413-00006-201	Lock Washer	2
9	G595-54001-0010	Foam Protection	1
10	G8620S-K04	Handle Assembly	1
11	G62S-03300-200	Vent Screw	1
12	G880-20007-0410	Return Spring	2
13	1413-00010-201	Lock Washer	1
14	G595-40005-0410	Handle Bolt	1
15	G736-40003-0410	Handle Base Pin	1

Item	Part No.	Description	Qty
16	G736-40005-0410	Roller	1
18	G880-20010-0410	Hydraulic Unit Attachment Screw	4
19	G595-20005-0410	Left Handle Bolt	1
20	G595-20006-0410	Right handle Bolt	1
21	1413-00020-201	Lock Washer	2
22	G736-20005-0410	Torsion Spring	1
23	G863-81003-0410	Spring Stop	1
24	1529-40030-031	Retainer	1
25	G863-83000-0000	Release Valve Assembly	1
26	G863-55001-1000	Handle Sleeve	1
27	G862-20004-0000	Cover	1
**	G8620S-K99	Seal Kit (includes a thru p)	1
-	29013E-M0	Manual	-
-	29013E-L0	Label	-

**Seal Kit Contents:

Item	Description	Qty
A	O-ring	1
B	O-ring	2
C	Back-up Ring	1
D	U-cup	1
E	Back-up Ring	1
F	O-ring	1
G	Washer, Metal	1
H	Back-up Washer	1
I	O-ring	2

Item	Description	Qty
J	O - Ring	1
K	Back-Up Washer	2
L	O - Ring	2
M	Retainer	1
N	Back-Up Washer	1
O	O - Ring	1
P	O - Ring	1

(**) Replacement requires special skills, knowledge, and equipment. Only an authorized service center may perform the repair and/or replacement of these items.

ONE YEAR LIMITED WARRANTY

For a period of one (1) year from date of purchase, **SFA Companies** will repair or replace, at its option, without charge, any of its products which fails due to a defect in material or workmanship under normal usage. This limited warranty is a consumer's exclusive remedy.

Performance of any obligation under this warranty may be obtained by returning the warranted product, freight prepaid, to **SFA Companies** Warranty Service Department, 10939 N. Pomona Ave., Kansas City, MO 64153.

Except where such limitations and exclusions are specifically prohibited by applicable law, (1) THE CONSUMER'S SOLE AND EXCLUSIVE REMEDY SHALL BE THE REPAIR OR REPLACEMENT OF DEFECTIVE PRODUCTS AS DESCRIBED ABOVE. (2) **SFA COMPANIES** SHALL NOT BE LIABLE FOR ANY CONSEQUENTIAL OR INCIDENTAL DAMAGE OR LOSS WHATSOEVER. (3) ANY IMPLIED WARRANTIES, INCLUDING WITHOUT LIMITATION THE IMPLIED WARRANTIES OF MERCHANTABILITY AND FITNESS FOR A PARTICULAR PURPOSE, SHALL BE LIMITED TO ONE YEAR, OTHERWISE THE REPAIR, REPLACEMENT OR REFUND AS PROVIDED UNDER THIS EXPRESS LIMITED WARRANTY IS THE EXCLUSIVE REMEDY OF THE CONSUMER, AND IS PROVIDED IN LIEU OF ALL OTHER WARRANTIES, EXPRESS OR IMPLIED. (4) ANY MODIFICATION, ALTERATION, ABUSE, UNAUTHORIZED SERVICE OR ORNAMENTAL DESIGN VOIDS THIS WARRANTY AND IS NOT COVERED BY THIS WARRANTY.

Some states do not allow limitations on how long an implied warranty lasts, so the above limitation may not apply to you. Some states do not allow the exclusion or limitation of incidental or consequential damages, so the above limitation or exclusion may not apply to you. This warranty gives you specific legal rights, and you may also have other rights, which vary from state to state.



K&L Supply Co.
2099 S 10th Street Unit 80
San Jose, CA USA 95112
sales@klsupply.com

SFA Companies
10939 N. Pomona Ave. Kansas City, MO 64153
888-332-6419
sales@omegalift.com