

Operator's Manual

Diaphragm Pump

PDI2A, PDI3A, PDT2A, PDT3A



Type	PDI2A, PDI3A, PDT2A, PDT3A
Document	5000184784
Date	0217
Revision	09
Language	EN



Copyright notice

© Copyright 2017 by Wacker Neuson Production Americas LLC

All rights, including copying and distribution rights, are reserved.

This publication may be photocopied by the original purchaser of the machine. Any other type of reproduction is prohibited without express written permission from Wacker Neuson Production Americas LLC.

Any type of reproduction or distribution not authorized by Wacker Neuson Production Americas LLC represents an infringement of valid copyrights. Violators will be prosecuted.

Trademarks

All trademarks referenced in this manual are the property of their respective owners.

Manufacturer

Wacker Neuson Production Americas LLC

N92W15000 Anthony Avenue

Menomonee Falls, WI 53051 U.S.A.

Tel: (262) 255-0500 · Fax: (262) 255-0550 · Tel: (800) 770-0957

www.wackerneuson.com

Original instructions

This Operator's Manual presents the original instructions. The original language of this Operator's Manual is American English.

Foreword

SAVE THESE INSTRUCTIONS—This manual contains important instructions for the machine models below. These instructions have been written expressly by Wacker Neuson Production Americas LLC and must be followed during installation, operation, and maintenance of the machines.

Machine	Item Number	Machine	Item Number
PDT2A	5000620769	PDT3A	5000620773
PDI2A(I)	5000620772	PDI3A	5000620775
		PDI3A(I)	5000620776

Machine documentation

- From this point forward in this documentation, Wacker Neuson Production Americas LLC will be referred to as Wacker Neuson.
- Keep a copy of the Operator’s Manual with the machine at all times.
- For spare parts information, please see your Wacker Neuson Dealer, or visit the Wacker Neuson website at <http://www.wackerneuson.com/>.
- When ordering parts or requesting service information, be prepared to provide the machine model number, item number, revision number, and serial number.

Expectations for information in this manual

- This manual provides information and procedures to safely operate and maintain the above Wacker Neuson model(s). For your own safety and to reduce the risk of injury, carefully read, understand, and observe all instructions described in this manual.
- Wacker Neuson expressly reserves the right to make technical modifications, even without notice, which improve the performance or safety standards of its machines.
- The information contained in this manual is based on machines manufactured up until the time of publication. Wacker Neuson reserves the right to change any portion of this information without notice.
- The illustrations, parts, and procedures in this manual refer to Wacker Neuson factory-installed components. Your machine may vary depending on the requirements of your specific region.

CALIFORNIA Proposition 65 Warning

Combustion exhaust, some of its constituents, and certain vehicle components contain or emit chemicals known to the State of California to cause cancer and birth defects or other reproductive harm.

Laws pertaining to spark arresters

NOTICE: State Health Safety Codes and Public Resources Codes specify that in certain locations spark arresters be used on internal combustion engines that use hydrocarbon fuels. A spark arrester is a device designed to prevent accidental discharge of sparks or flames from the engine exhaust. Spark arresters are qualified and rated by the United States Forest Service for this purpose. In order to comply with local laws regarding spark arresters, consult the engine distributor or the local Health and Safety Administrator.



Manufacturer's approval

This manual contains references to *approved* parts, attachments, and modifications. The following definitions apply:

- **Approved parts or attachments** are those either manufactured or provided by Wacker Neuson.
- **Approved modifications** are those performed by an authorized Wacker Neuson service center according to written instructions published by Wacker Neuson.
- **Unapproved parts, attachments, and modifications** are those that do not meet the approved criteria.

Unapproved parts, attachments, or modifications may have the following consequences:

- Serious injury hazards to the operator and persons in the work area
- Permanent damage to the machine which will not be covered under warranty

Contact your Wacker Neuson dealer immediately if you have questions about approved or unapproved parts, attachments, or modifications.



EC Declaration of Conformity

Manufacturer

Wacker Neuson Production Americas LLC, N92W15000 Anthony Avenue,
Menomonee Falls, Wisconsin 53051 USA

Product

Product	PDI2A(i)	PDI3A(i)
Product category	Water Pump Units	
Product function	To pump fluid	
Item number	5000620772	5000620776
Net installed power	2.6 kW	
Measured sound power level	95 dB(A)	96 dB(A)
Guaranteed sound power level	97 dB(A)	98 dB(A)

Conformity Assessment Procedure

According to 2000/14/EC ANNEX V

Notified Body

Lloyds Register Verification Limited (Notified Body No 0038)
71 Fenchurch Street, London EC3M 4BS, United Kingdom

Directives and Standards

We hereby declare that this product meets and complies with the relevant regulations and requirements of the following directives and standards:

2006/42/EC, 2000/14/EC, EN 809:1998

Authorized Person for Technical Documents

Robert Raethsel, Wacker Neuson Produktion GmbH & Co. KG, Wackerstrasse 6,
85084 Reichertshofen, Germany

Menomonee Falls, WI, USA, 21.02.17

Keith Herr
Vice President and Managing Director
For Wacker Neuson

Jeff Volden
Director, Product Engineering
For Wacker Neuson

Travis Pound
Manager, Product Engineering
For Wacker Neuson

Foreword	3
EC Declaration of Conformity	5
1 Safety Information	9
1.1 Signal Words Used in this Manual	9
1.2 Machine Description and Intended Use	10
1.3 Operating Safety	11
1.4 Service Safety	12
1.5 Operator Safety while Using Internal Combustion Engines	14
2 Labels	15
2.1 Label Locations	15
2.2 Label Meanings	16
3 Lifting and Transporting	21
4 Operation	22
4.1 Preparing the Machine for First Use	22
4.2 Hoses and Clamps	22
4.3 Recommended Fuel	23
4.4 Refueling the Machine	24
4.5 Before Installing the Pump	25
4.6 Installing the Pump	26
4.7 Starting	27
4.8 Stopping	28
4.9 Running the Pump	29
4.10 Clearing Jams	30
4.11 Emergency Shutdown Procedure	31
5 Maintenance	32
5.1 Maintaining the Emission Control System	32
5.2 Periodic Maintenance Schedule	32
5.3 Servicing the Air Cleaner	34
5.4 Greasing the Connecting Rod Bearing	35
5.5 Changing the Engine Oil	36
5.6 Cleaning the Sediment Cup	37

5.7	Spark Plug	38
5.8	Changing the Gearbox Oil	39
5.9	Cleaning the Pump	40
5.10	Storage	41
5.11	Machine Disposal and Decommissioning	42
6	Troubleshooting	43
7	Technical Data	45
7.1	Engine	45
7.2	Pump	46
7.3	Sound Measurements	46
7.4	Dimensions	47
8	Emission Control Systems Information and Warranty	48
8.1	Emission Control Systems Warranty Statement	48
9	AEM Safety Manual	49

1 Safety Information

1.1 Signal Words Used in this Manual

This manual contains DANGER, WARNING, CAUTION, *NOTICE*, and NOTE signal words which must be followed to reduce the possibility of personal injury, damage to the equipment, or improper service.



This is the safety alert symbol. It is used to alert you to potential personal hazards.

- ▶ Obey all safety messages that follow this symbol.
-



DANGER

DANGER indicates a hazardous situation which, if not avoided, will result in death or serious injury.

- ▶ To avoid death or serious injury from this type of hazard, obey all safety messages that follow this signal word.
-



WARNING

WARNING indicates a hazardous situation which, if not avoided, could result in death or serious injury.

- ▶ To avoid possible death or serious injury from this type of hazard, obey all safety messages that follow this signal word.
-



CAUTION

CAUTION indicates a hazardous situation which, if not avoided, could result in minor or moderate injury.

- ▶ To avoid possible minor or moderate injury from this type of hazard, obey all safety messages that follow this signal word.
-

NOTICE: Used without the safety alert symbol, NOTICE indicates a situation which, if not avoided, could result in property damage.

Note: A Note contains additional information important to a procedure.

1.2 Machine Description and Intended Use

Machine description This machine is a diaphragm pump. The Wacker Neuson Diaphragm Pump consists of a gasoline engine, a fuel tank, a handle, a set of wheels, and a diaphragm pump with ports for fluid suction and discharge. The engine raises and lowers the diaphragm via a connecting rod. The operator connects hoses to the pump and routes them so that water and solids are drained from the work area and discharged into an appropriate location.

Intended use This machine is intended to be used for general de-watering applications. This machine is intended for the pumping of clear water, or water containing solids up to the size stated within the product specifications, and up to the flow, head, and suction lift limits also stated within the product specifications.

This machine has been designed and built strictly for the intended use described above. Using the machine for any other purpose could permanently damage the machine or seriously injure the operator or other persons in the area. Machine damage caused by misuse is not covered under warranty.

The following are some examples of misuse:

- Pumping flammable, explosive, or corrosive fluids
 - Pumping hot or volatile fluids that result in pump cavitation
 - Operating the pump outside of product specifications due to incorrect diameter hoses, incorrect length hoses, other inlet or outlet restrictions, or excessive suction lift or head
 - Using the machine as a ladder, support, or work surface
 - Using the machine to carry or transport passengers or equipment
 - Operating the machine outside of factory specifications
 - Operating the machine in a manner inconsistent with all warnings found on the machine and in the Operator's Manual
-

This machine has been designed and built in accordance with the latest global safety standards. It has been carefully engineered to eliminate hazards as far as practicable and to increase operator safety through protective guards and labeling. However, some risks may remain even after protective measures have been taken. They are called residual risks. On this machine, they may include exposure to:

- Heat, noise, exhaust, and carbon monoxide from the engine
- Fire hazards from improper refueling techniques
- Fuel and its fumes
- Personal injury from improper lifting techniques
- Projectile hazard from discharge
- Crushing hazards from a tipping or falling pump

To protect yourself and others, make sure you thoroughly read and understand the safety information presented in this manual before operating the machine.

1.3 Operating Safety

Operator training

Before operating the machine:

- Read and understand the operating instructions contained in all manuals delivered with the machine.
- Familiarize yourself with the location and proper use of all controls and safety devices.
- Contact Wacker Neuson for additional training if necessary.

When operating this machine:

- Do not allow improperly trained people to operate the machine. People operating the machine must be familiar with the potential risks and hazards associated with it.

Operator qualifications

Only trained personnel are permitted to start, operate, and shut down the machine. They also must meet the following qualifications:

- have received instruction on how to properly use the machine
- are familiar with required safety devices

The machine must not be accessed or operated by:

- children
- people impaired by alcohol or drugs

Application area

Be aware of the application area.

- Keep unauthorized personnel, children, and pets away from the machine.
- Remain aware of changing positions and the movement of other equipment and personnel in the application area/job site.
- Identify whether special hazards exist in the application area, such as toxic gases, or unstable ground conditions, and take appropriate action to eliminate the special hazards before using the machine.

Be aware of the application area.

- Do not operate the machine in areas that contain flammable objects, fuels, or products that produce flammable vapors.

Safety devices, controls, and attachments

Only operate the machine when:

- All safety devices and guards are in place and in working order.
- All controls operate correctly.
- The machine is set up correctly according to the instructions in the Operator's Manual.
- The machine is clean.
- The machine's labels are legible.

To ensure safe operation of the machine:

- Do not operate the machine if any safety devices or guards are missing or inoperative.
- Do not modify or defeat the safety devices.
- Do not use accessories or attachments that are not approved by Wacker Neuson.

Operating guidelines

When operating this machine:

- Ensure that the machine is on a firm, level surface and that it will not tip, roll, slide, or fall while operating.

When operating this machine:

- Do not pump volatile, flammable, or low-flash-point fluids.
 - Do not change hoses while the engine is running.
 - Do not attempt to move the machine while the engine is running.
-

Personal Protective Equipment (PPE)

Wear the following Personal Protective Equipment (PPE) while operating this machine:

- Close-fitting work clothes that do not hinder movement
- Safety glasses with side shields
- Hearing protection
- Safety-toed footwear

1.4 Service Safety

Service training

Before servicing or maintaining the machine:

- Read and understand the instructions contained in all manuals delivered with the machine.
- Familiarize yourself with the location and proper use of all controls and safety devices.
- Only trained personnel should troubleshoot or repair problems occurring with the machine.
- Contact Wacker Neuson for additional training if necessary.

When servicing or maintaining this machine:

- Do not allow improperly trained people to service or maintain the machine. Personnel servicing or maintaining the machine must be familiar with the associated potential risks and hazards.
-

Precautions

Follow the precautions below when servicing or maintaining the machine.

- Read and understand the service procedures before performing any service to the machine.
- All adjustments and repairs must be completed before operation. Do not operate the machine with a known problem or deficiency.
- All repairs and adjustments shall be completed by a qualified technician.
- Turn off the machine before performing maintenance or making repairs.

Personal Protective Equipment (PPE)

Wear the following Personal Protective Equipment (PPE) while servicing or maintaining this machine:

- Close-fitting work clothes that do not hinder movement
- Safety glasses with side shields
- Hearing protection
- Safety-toed footwear

In addition, before servicing or maintaining the machine:

- Tie back long hair.
 - Remove all jewelry (including rings).
-

Machine modifications

When servicing or maintaining the machine:

- Use only accessories/attachments that are approved by Wacker Neuson.

When servicing or maintaining the machine:

- Do not defeat safety devices.
 - Do not modify the machine without the express written approval of Wacker Neuson.
-

Replacing parts and labels

- Replace worn or damaged components.
 - Replace all missing and hard-to-read labels.
 - When replacing electrical components, use components that are identical in rating and performance to the original components.
 - When replacement parts are required for this machine, use only Wacker Neuson replacement parts or those parts equivalent to the original in all types of specifications, such as physical dimensions, type, strength, and material.
-

Lifting and transporting

When lifting the machine:

- Make sure slings, chains, hooks, ramps, jacks, and other types of lifting devices are attached securely and have enough weight-bearing capacity to lift or hold the machine safely. See chapter *Technical Data*.
- Remain aware of the location of other people when lifting the machine.
- Make sure the transporting vehicle has sufficient load capacity and platform size to safely transport the machine. See chapter *Technical Data*.

To reduce the possibility of injury:

- Do not stand under the machine while it is being lifted or moved.
 - Do not get onto the machine while it is being lifted or moved.
-

Cleaning

When cleaning and servicing the machine:

- Keep the machine clean and free of debris such as leaves, paper, cartons, etc.
- Keep the labels legible.

When cleaning the machine:

- Do not clean the machine while it is running.
- Never use gasoline or other types of fuels or flammable solvents to clean the machine. Fumes from fuels and solvents can become explosive.

1.5 Operator Safety while Using Internal Combustion Engines

**WARNING**

Internal combustion engines present special hazards during operation and fueling. Failure to follow the warnings and safety standards could result in severe injury or death.

- ▶ Read and follow the warning instructions in the engine owner's manual and the safety guidelines below.

**DANGER**

Asphyxiation hazard. Using a pump indoors **CAN KILL YOU IN MINUTES**. Pump exhaust contains carbon monoxide. This is a poison you cannot see or smell.

- ▶ **NEVER** use this pump inside a home or garage, **EVEN IF** doors and windows are open. Only use **OUTSIDE** and far away from windows, doors, and vents.
- ▶ **NEVER** use a pump inside an enclosed area, such as a tunnel or a trench, unless adequate ventilation is provided through such items as exhaust fans or hoses.

Operating safety

When operating the pump:

- Keep the area around exhaust pipe free of flammable materials.
- Check the fuel lines and the fuel tank for leaks and cracks before starting the engine.

When operating the pump:

- Do not smoke while operating the machine.
- Do not run the machine if fuel leaks are present or the fuel lines are loose.
- Do not run the engine near sparks or open flames.
- Do not touch the engine or muffler while the engine is running or immediately after it has been turned off.
- Do not operate a machine when its fuel cap is loose or missing.
- Do not start the engine if fuel has spilled or a fuel odor is present. Move the machine away from the spill and wipe the machine dry before starting.

Refueling safety

When refueling the engine:

- Clean up any spilled fuel immediately.
- Refill the fuel tank in a well-ventilated area.
- Replace the fuel tank cap after refueling.

When refueling the engine:

- Do not smoke.
- Do not refuel a hot or running engine.
- Do not refuel the engine near sparks or open flames.
- Do not refuel if the machine is positioned in a truck fitted with a plastic bed liner. Static electricity can ignite the fuel or fuel vapors.





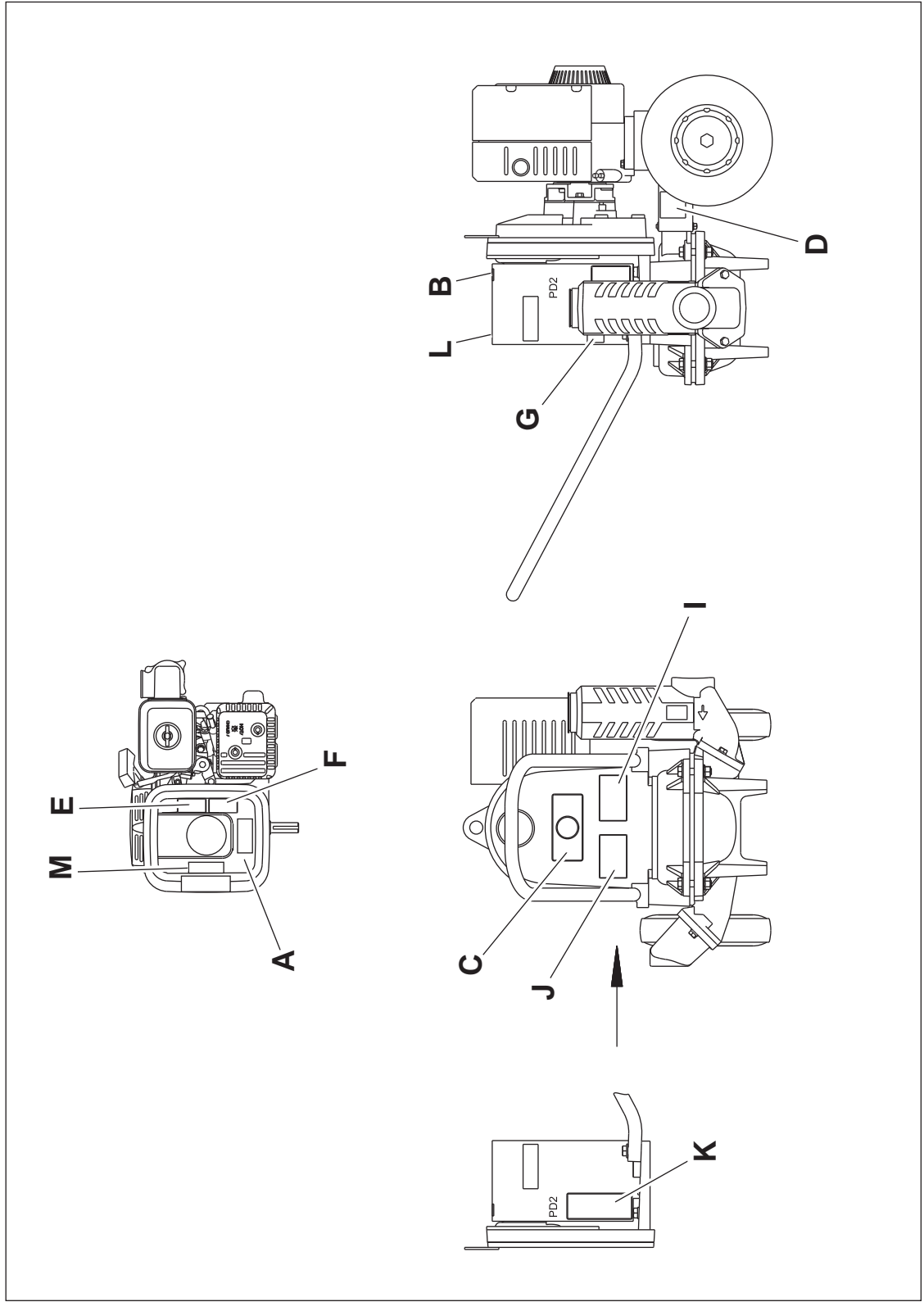

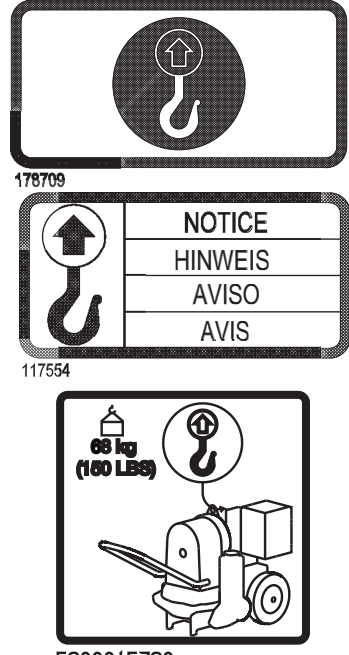
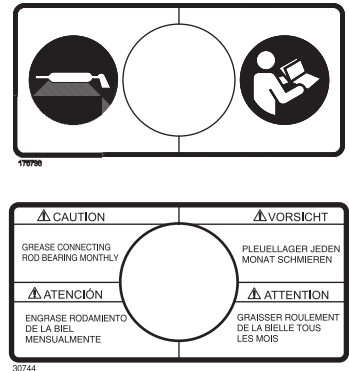

2 Labels



2.1 Label Locations



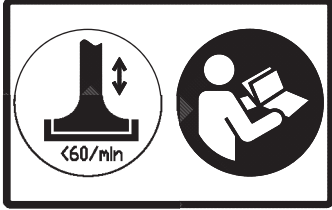
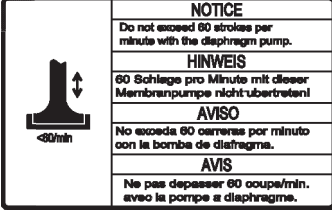
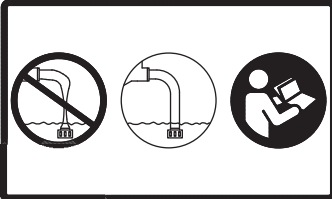
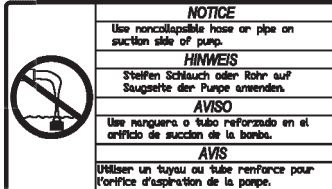
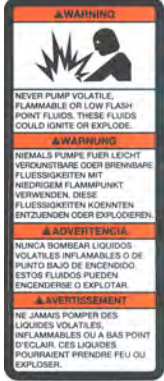

2.2 Label Meanings

<p>A</p>		<p>DANGER Asphyxiation hazard.</p> <ul style="list-style-type: none"> Engines emit carbon monoxide. Do not run the machine indoors or in an enclosed area. NEVER use inside a home or garage, EVEN IF doors and windows are open. <p>Only use OUTSIDE and far away from windows, doors, and vents.</p> <ul style="list-style-type: none"> Read the Operator's Manual. No sparks, flames, or burning objects near the machine. Stop the engine before refueling.
<p>B</p>		<p>NOTICE Lifting point</p>
<p>C</p>		<p>CAUTION Grease connecting rod bearing monthly.</p> <p>Read the Operator's Manual.</p>

<p>D</p>	  <p>178799</p>  <p>117431</p>	<p>WARNING Pinch point! Do not operate without safety guards. Read and understand the Operator's Manual.</p>
<p>E</p>	 <p>178714</p>  <p>0117045</p>	<p>CAUTION Read and understand the supplied Operator's Manual before operating this machine. Failure to do so increases the risk of injury to yourself and others.</p>
<p>F</p>	 <p>178713</p> 	<p>WARNING Hot surface</p>
<p>G</p>	 	<p>Guaranteed sound power level in db(A)</p>

<p>I</p>	 <p>182177</p>  <p>182176</p> <table border="1" data-bbox="630 432 850 640"> <tr> <td>NOTICE</td> </tr> <tr> <td>Do not exceed 60 strokes per minute with the diaphragm pump.</td> </tr> <tr> <td>HINWEIS</td> </tr> <tr> <td>60 Schläge pro Minute mit dieser Membranpumpe nicht übersteigen!</td> </tr> <tr> <td>AVISO</td> </tr> <tr> <td>No exceda 60 carreras por minuto con la bomba de diafragma.</td> </tr> <tr> <td>AVIS</td> </tr> <tr> <td>Ne pas dépasser 60 coups/min. avec la pompe à diaphragme.</td> </tr> </table>	NOTICE	Do not exceed 60 strokes per minute with the diaphragm pump.	HINWEIS	60 Schläge pro Minute mit dieser Membranpumpe nicht übersteigen!	AVISO	No exceda 60 carreras por minuto con la bomba de diafragma.	AVIS	Ne pas dépasser 60 coups/min. avec la pompe à diaphragme.	<p>Notice Do not exceed 60 strokes per minute with the diaphragm pump. Read the Operator's Manual.</p>
NOTICE										
Do not exceed 60 strokes per minute with the diaphragm pump.										
HINWEIS										
60 Schläge pro Minute mit dieser Membranpumpe nicht übersteigen!										
AVISO										
No exceda 60 carreras por minuto con la bomba de diafragma.										
AVIS										
Ne pas dépasser 60 coups/min. avec la pompe à diaphragme.										
<p>J</p>	 <p>182179</p>  <p>182178</p> <table border="1" data-bbox="630 947 850 1134"> <tr> <td>NOTICE</td> </tr> <tr> <td>Use noncollapsible hose or pipe on suction side of pump.</td> </tr> <tr> <td>HINWEIS</td> </tr> <tr> <td>Streifen Schlauch oder Rohr auf Saugseite der Pumpe vermeiden.</td> </tr> <tr> <td>AVISO</td> </tr> <tr> <td>Use manguera o tubo reforzado en el orificio de succión de la bomba.</td> </tr> <tr> <td>AVIS</td> </tr> <tr> <td>Utiliser un tuyau ou tube renforcé pour l'orifice d'aspiration de la pompe.</td> </tr> </table>	NOTICE	Use noncollapsible hose or pipe on suction side of pump.	HINWEIS	Streifen Schlauch oder Rohr auf Saugseite der Pumpe vermeiden.	AVISO	Use manguera o tubo reforzado en el orificio de succión de la bomba.	AVIS	Utiliser un tuyau ou tube renforcé pour l'orifice d'aspiration de la pompe.	<p>Notice Use noncollapsible hose or pipe on suction side of pump. Read the Operator's Manual.</p>
NOTICE										
Use noncollapsible hose or pipe on suction side of pump.										
HINWEIS										
Streifen Schlauch oder Rohr auf Saugseite der Pumpe vermeiden.										
AVISO										
Use manguera o tubo reforzado en el orificio de succión de la bomba.										
AVIS										
Utiliser un tuyau ou tube renforcé pour l'orifice d'aspiration de la pompe.										
<p>K</p>	 <p>151049</p>  <p>179764</p>	<p>WARNING Never pump volatile, flammable, or low-flash-point fluids. These fluids could ignite or explode. Read the Operator's Manual.</p>								

<p>L</p>		<p>Certified Performance Contractors Pump Bureau A Bureau of AEM The manufacturer of this pump certifies that it was manufactured in accordance with the standards of the Contractors Pump Bureau.</p>
<p>M</p>	<div data-bbox="664 575 1187 690" style="border: 1px solid black; padding: 5px; margin-bottom: 10px;"> <p style="text-align: center;"> WARNING</p> <p style="font-size: small;">Operation of This Equipment May Create Sparks That Can Start Fires Around Dry Vegetation. A Spark Arrestor May be Required. The Operator Should Contact Local Fire Agencies For Laws or Regulations Relating to Fire Prevention Requirements. Per CAL. PRC. CODE</p> </div> <p>WARNING Operation of this equipment may create sparks that can start fires around dry vegetation. A spark arrester may be required. The operator should contact local fire agencies for laws or regulations relating to fire prevention requirements.</p>	

Notes

3 Lifting and Transporting

- Requirements**
- Transport vehicle capable of carrying at least 70 kg (150 lbs.)
 - Use lifting equipment capable of lifting at least 70 kg (150 lbs.)



WARNING

Fire hazard. Spilled fuel can ignite and cause severe burns.

- ▶ Lift and transport the machine in an upright position.

Guidelines

Follow the guidelines below when lifting and transporting this machine.

- Close the fuel valve.
- Lift and transport it in an upright position.
- Use the lifting hook (**d**) to lift the machine.

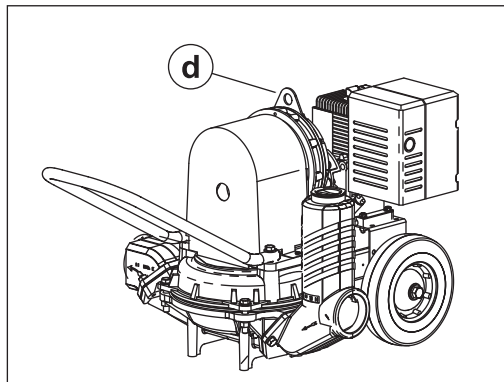

wc_gr007150

- To secure the machine to the transport vehicle, attach strapping (**b**) across the handle. Also attach strapping (**a**) across the frame of the machine.

NOTICE: Do not use the wheels or the casting (**c**) as tie down locations.

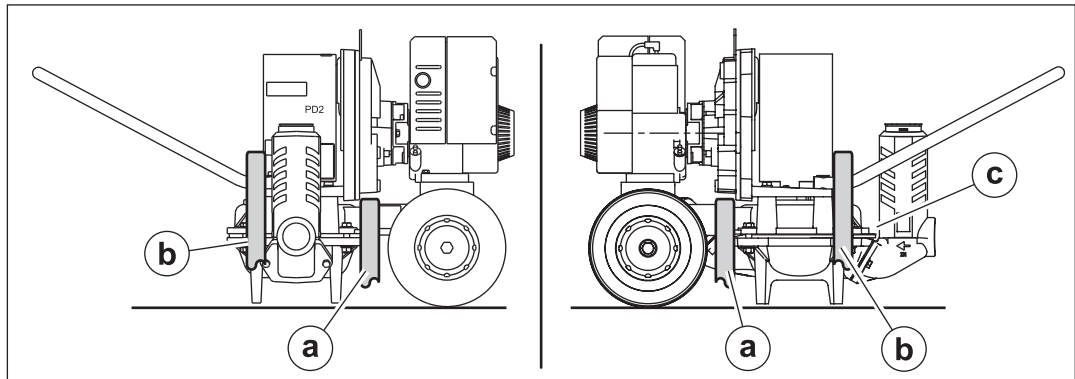

wc_gr007149

4 Operation

4.1 Preparing the Machine for First Use

1. Make sure all loose packaging materials have been removed from the machine.
2. Check the machine and its components for damage. If there is visible damage, do not operate the machine! Contact your Wacker Neuson dealer immediately for assistance.
3. Take inventory of all items included with the machine and verify that all loose components and fasteners are accounted for.
4. Attach component parts not already attached.
5. Add fluids as needed and applicable, including fuel, engine oil, and battery acid.
6. Move the machine to its operating location.

4.2 Hoses and Clamps

Guidelines Follow the guidelines below for hoses and clamps.

- Use only noncollapsible hoses for the suction side of the pump.

Note: *Suction and discharge hoses are available from Wacker Neuson. Contact your nearest dealer for more information.*

- Use two clamps for connecting suction hoses to the inlet coupling of the pump.

Note: *This connection is important. Even a small air leak on the suction side of pump will prevent the pump from priming.*

- For other hose connections, one T-bolt or worm-gear type clamp is usually sufficient to hold hoses in place. In some cases, slight variances in hose diameters may make it necessary to add more clamps in order to maintain tight connections.

4.3 Recommended Fuel

Type	<p>This engine/equipment requires regular unleaded gasoline.</p> <ul style="list-style-type: none">■ Use only fresh (no older than three months old), clean gasoline.■ Use a fuel stabilizer per the fuel stabilizer manufacturer's instructions. <hr/>
Use of oxygenated fuels	<p>Some conventional gasolines are blended with alcohol. These gasolines are collectively referred to as oxygenated fuels. If you use an oxygenated fuel, be sure it is unleaded and meets the minimum octane rating requirement.</p> <p>Before using an oxygenated fuel, confirm the fuel's contents. Some states and provinces require this information to be posted on the fuel pump.</p> <p>The following is the Wacker Neuson approved percentage of oxygenates:</p> <p>ETHANOL - (ethyl or grain alcohol) 10% by volume. You may use gasoline containing up to 10% ethanol by volume (commonly referred to as E10). Gasoline containing more than 10% ethanol (such as E15, E20, or E85) may not be used because it could damage the engine.</p> <p>If you notice any undesirable operating symptoms, try another service station, or switch to another brand of gasoline.</p> <p>Fuel system damage or performance problems resulting from the use of an oxygenated fuel containing more than the percentages of oxygenates mentioned above are not covered under warranty.</p>

4.4 Refueling the Machine

- Requirements**
- Machine shut down
 - Engine cool
 - Machine/fuel tank level with the ground
 - Fresh, clean fuel supply

Procedure Perform the procedure below to refuel the machine.



WARNING

Fire hazard. Fuel and its vapors are extremely flammable. Burning fuel can cause severe burns.

- ▶ Keep all sources of ignition away from the machine while refueling.
- ▶ Do not refuel if the machine is positioned in a truck fitted with a plastic bed liner. Static electricity can ignite the fuel or fuel vapors.
- ▶ Refuel only when the machine is outdoors.
- ▶ Clean up spilled fuel immediately.

1. Remove the fuel cap (a).

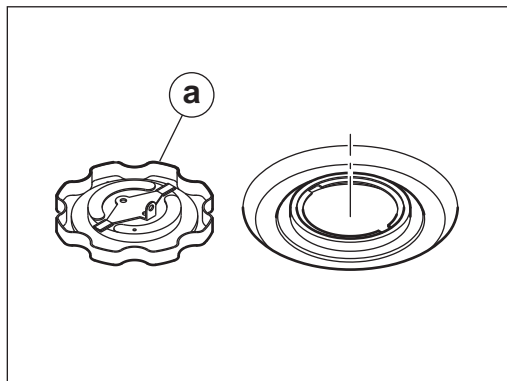

wc_gr008400

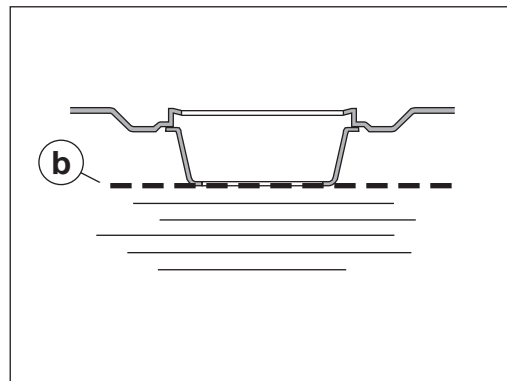

wc_gr008401

2. Fill the fuel tank to the bottom of the fuel tank neck (b).



CAUTION

Fire and health hazard. Fuel expands when heated. Expanding fuel in an overfilled tank can lead to spills and leaks.

- ▶ Do not overfill the fuel tank.

3. Re-install the fuel cap.

Result The procedure to refuel the machine is now complete.

4.5 Before Installing the Pump

- Requirements**
- API GL-5 rated gear oil
 - Machine off
-

Tasks

Perform the tasks below before installing the pump.

1. Read the safety instructions at the beginning of this manual.
2. Place the pump on a firm, flat, level surface.
3. Check fuel level. Add fuel as needed.
4. Check engine oil level. Add engine oil as needed.
5. Check condition of air filter. Replace the air filter if needed.
6. Fill the pump's gearbox with oil.
 - a. Remove the fill plug **(a)**.

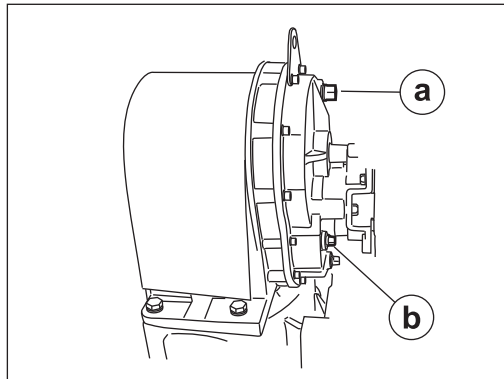

wc_gr007154

- b. Remove the level plug **(b)**.
 - c. Slowly pour gear oil into the fill hole until it comes out of the level hole.
 - d. Re-install the fill and level plugs.
-

Result

The pump is now ready to be installed.

4.6 Installing the Pump

- Requirements**
- Hoses
 - Hose couplings
 - Suction strainer
 - Clamps

Procedure Perform the procedure below to install the pump.

NOTICE: Do not use collapsible hoses on the suction side of the pump.

1. Place the pump as near to the water to be pumped as possible.
2. Check that hose couplings/nipples (**b**) are installed and secure.

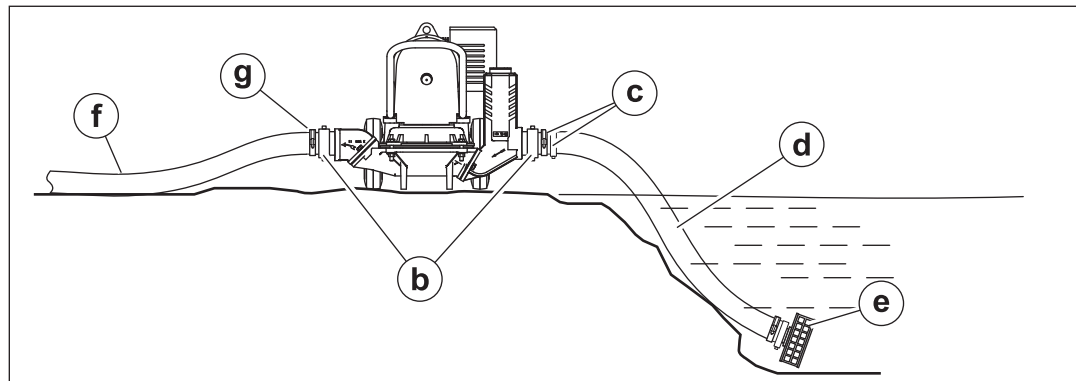

wc_gr007137

3. Make sure the suction strainer (**e**) is clean and securely attached to the end of the suction hose.
4. Connect the suction hose (**d**) to the pump with two clamps (**c**). Position the suction hose so that:
 - there is a continual upward slope from the water source to the pump
 - the suction hose/strainer in the water source will stay submerged as the water source level drops
 - the suction hose is as short as possible
 - there are no loops in the suction hose
 - there are no air leaks.
5. Connect the discharge hose (**f**) to the pump with clamp (**g**).
6. Lay the discharge hose (**f**) out as straight as possible. Position the discharge hose so that:
 - there are no sharp bends or loops in the hose
 - the hose is less than 8.1 m (25 ft) above or away from the pump
 - the hose is not a tripping hazard on the job site.

NOTICE: Maximum discharge head is 8.1 m (25 ft) or 0.8 bar (10.9 psi). Operating the pump over this head or pressure will cause the pump to stall and/or gearbox damage.

4.7 Starting

- Requirements**
- Completed installation procedures
 - Engine owner's manual read and understood

Procedure Perform the procedure below to start the machine.

1. Set the fuel valve lever **(a)** to the OPEN position **(a₁)**.

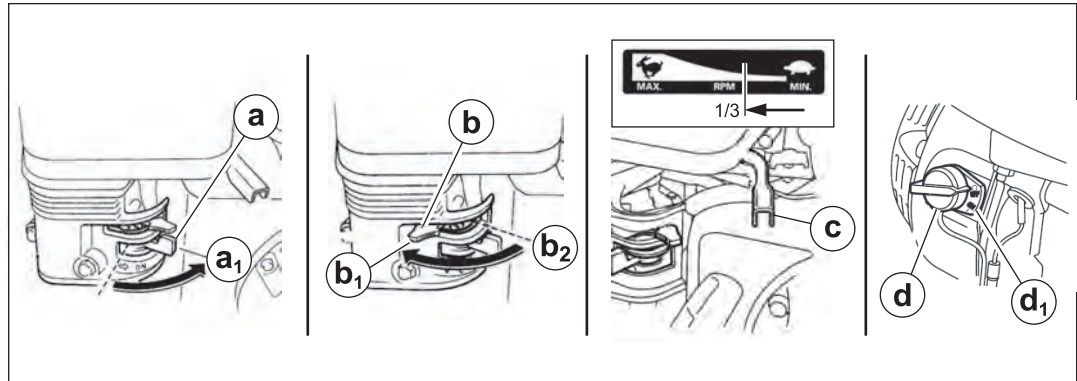

wc_gr007159

2. Set the choke lever **(b)** to the CLOSED position **(b₁)**. If the engine is warm, the choke lever may be left in the OPEN position **(b₂)**.
3. Set the throttle lever **(c)** approximately 1/3 of the way to the "MAX." position.
4. Turn the engine switch **(d)** to the ON position **(d₁)**.
5. Pull the starter rope until the engine starts.

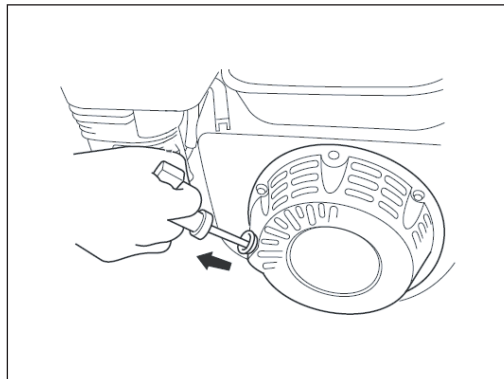

wc_gr007157

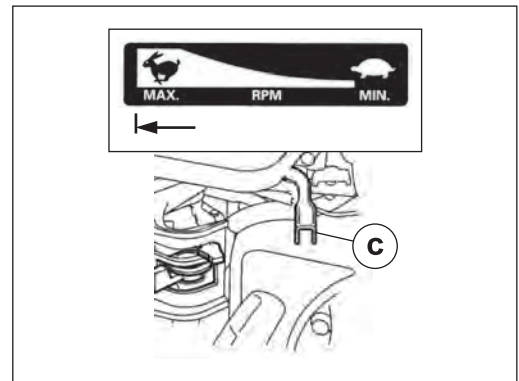

wc_gr007158

6. Set the choke lever to the OPEN position as the engine warms.
7. Set the throttle to "MAX." position to run the pump.

4.8 Stopping

Procedure Perform the procedure below to stop the machine.

Note: To stop the engine in an emergency, move the engine switch to the OFF position. In all other circumstances, use the following procedure.

1. Set the throttle lever **(c)** to "MIN." position.

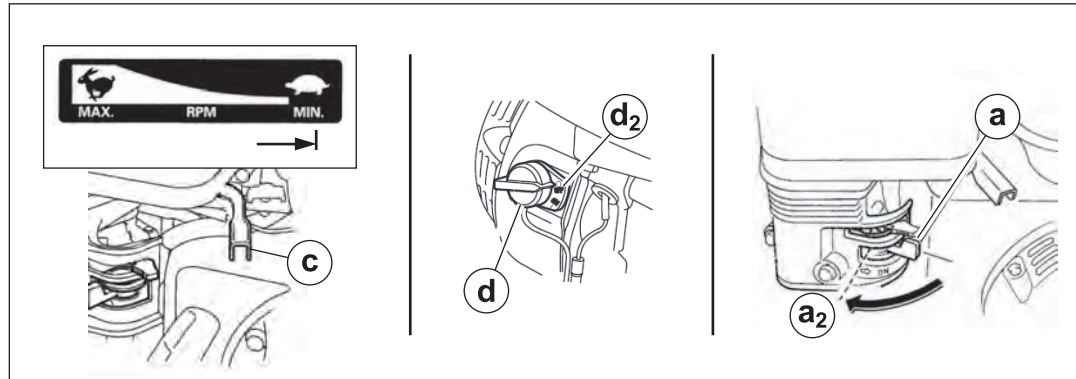

wc_gr007160

2. Turn the engine switch **(d)** to the OFF position **(d₂)**.
3. Set the fuel valve lever **(a)** to the CLOSED position **(a₂)**.

4.9 Running the Pump

Guidelines Follow the guidelines below when running the pump.

- Run the engine at full speed.

NOTICE: Pump speed must not exceed 60 strokes per minute (2800 rpm).

- The pump should begin pumping water within one minute of being started depending on hose length and height above water. Longer hoses will require more time.
- If the pump does not prime:
 - a. check for loose fittings, air leaks, and plugged strainer.
 - b. stop the engine, remove plug **(a)**, add water, re-install plug, and restart the engine.

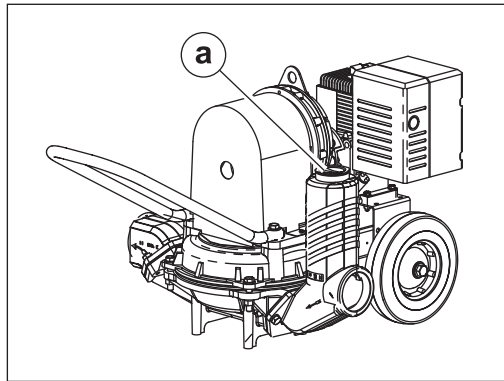

wc_gr007161

4.10 Clearing Jams

Overview Large solids or accumulated sand and sediment may become lodged in the pump housing. This debris prevents the plunger arm from making a full stroke, causing the pump to stall or the crank to slip on the output shaft. The debris must be cleared before resuming operation.

- Prerequisites**
- Engine is stopped
 - Machine is cool to the touch

If the pump has stalled Perform the procedure below to clear a jam if the pump has stalled.

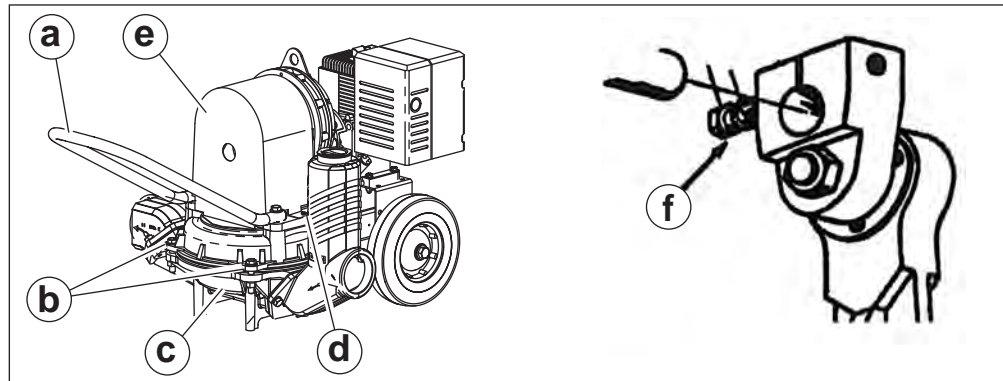

wc_gr008182

1. Remove the handle **(a)**.
2. Remove the four bolts **(b)** securing the pump housing **(c)**.
3. Clean all debris and obstructions from the pump housing.
4. Re-install the four bolts and handle.

If the crank is slipping Perform the procedure below to retighten the crank if a jam has caused it to slip.

1. Loosen the hand knob screws **(d)** and remove the metal guard **(e)**.
2. Remove the handle and bolts as described in the above procedure.
3. Clean all debris and obstructions from the pump housing.
4. Loosen the crank lockscrew **(f)**. Torque the crank lockscrew to 95 Nm (70 ft.lbs.)

NOTICE: Do not over-torque or under-torque the lockscrew! Improper torque can break the connecting rod or cause premature wear of internal parts.

5. Re-install the metal guard, handle, and bolts.

4.11 Emergency Shutdown Procedure

Procedure Perform the procedure below if a breakdown/accident occurs while the machine is operating.

1. Stop the engine.
2. Turn off the fuel.
3. Remove the obstruction.
4. Unkink the hoses.
5. Allow the machine to cool.
6. Contact the rental yard or machine owner.

5 Maintenance

5.1 Maintaining the Emission Control System

Normal maintenance, replacement or repair of emission control devices and systems may be performed by any repair establishment or individual; however, warranty repairs must be performed by a dealer/service center authorized by the engine manufacturer. See the supplied engine owner’s manual for the applicable emission warranty information.

5.2 Periodic Maintenance Schedule

The table below lists basic machine and engine maintenance. Tasks designated with check marks may be performed by the operator. Tasks designated with square bullet points require special training and equipment.

Refer to the engine owner’s manual for additional information.

Task	Interval* (hours of service)				
	Daily before starting ---	First month (20)	Monthly (40)	6 months (100)	Yearly (300)
Check fuel level.	✓				
Check engine oil level.	✓				
Inspect air cleaner elements. Replace as needed.	✓				
Check external hardware.	✓				
Grease connecting rod bearing.			■		
Change engine oil.		■		■	
Check oil level in pump gearbox.			■		
Clean engine sediment cup.				■	
Clean spark plug.				■	
Change oil in pump gearbox.				■	
* Use whichever comes first, calendar time or service hours.					

Task	Interval* (hours of service)				
	Daily before starting ---	First month (20)	Monthly (40)	6 months (100)	Yearly (300)
Check and adjust valve engine clearances					■
Check and adjust idle speed					■
Replace fuel filter					■
* Use whichever comes first, calendar time or service hours.					

5.3 Servicing the Air Cleaner

When Inspect the air cleaner elements daily. Clean the air cleaner elements as needed. Replace the air cleaner elements if they are damaged or cannot be cleaned.

Requirements

- Machine shut down
- Mild detergent and warm water
- Clean engine oil



WARNING

Fire or explosion hazards. Gasoline or low-flash-point solvents are flammable and must not be used to clean the air cleaner or filter element.

► Use only mild detergent and warm water to clean the air cleaner and filter element.

NOTICE: Do not run the engine without the air cleaner or filter elements. Severe engine damage will occur!

Procedure Perform the procedure below to service the air cleaner.

1. Stop the engine.
2. Remove the wing nut **(a)** and remove the air cleaner cover **(b)**.

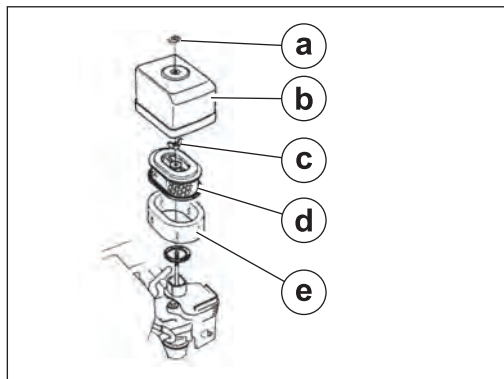

wc_gr007168

3. Remove the second wing nut **(c)** and remove the air filter.

Note: The air filter has two elements: a foam element and a paper element.

4. Remove the foam element **(e)** from the paper element **(d)**.

5. Clean the elements if they are to be reused.

■ Paper element

- a. Tap the paper element on a hard surface to remove dirt, or blow low-pressure (less than 207 kPa (30 psi)) through the paper element from the inside.

NOTICE: Do not try to brush dirt off the paper element. Brushing will force dirt into the fibers of the paper element.

This procedure continues on the next page.

Continued from the previous page.

- Foam element
 - a. Wash the foam element in a solution of mild detergent and warm water.
 - b. Rinse the foam element thoroughly in clean water, and allow it to dry completely.
 - c. Soak the foam element in clean engine oil until saturated. Squeeze out excess oil.
- 6. Re-install the filter elements and air cleaner cover.

Note: *In the interests of environmental protection, dispose of waste oil and soiled rags in accordance with environmental protection legislation.*

5.4 Greasing the Connecting Rod Bearing

When Grease the connecting rod bearing every 40 hours of operation or monthly.

Requirements

- General automotive grease
- Machine shut down

Procedure Perform the procedure below to grease the connecting rod bearing.

1. Stop the engine.
2. Access the grease fitting of the connecting rod bearing through the access hole **(a)**.

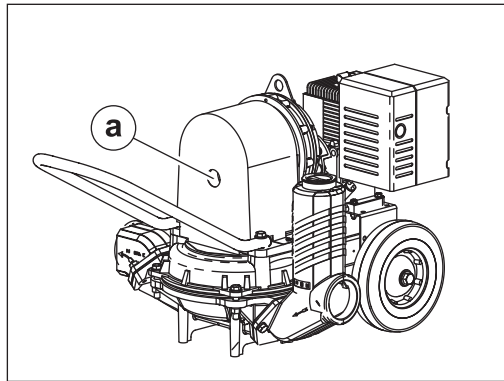

wc_gr007184

3. Using a grease gun, pump grease into the fitting until new grease seeps out between the bearing and the journal.

5.5 Changing the Engine Oil

When Change the engine oil after the first 20 hours of operation and then after every 100 hours of operation or 6 months, whichever comes first.

- Requirements**
- Warm engine
 - Plastic sheet to protect against drips or spills
 - Container of sufficient volume to collect waste oil
 - Replacement oil (see *Technical Data* for quantity and type)
 - New gasket



WARNING

Most used oil contains small amounts of materials that can cause cancer and other health problems if inhaled, ingested, or left in contact with skin for prolonged periods of time.

- ▶ Take steps to avoid inhaling or ingesting used engine oil.
- ▶ Wash skin thoroughly after exposure to used engine oil.

Procedure Perform the procedure below to replace the engine oil.

1. Position the machine on a flat, level surface.
2. Stop the engine.
3. Place the plastic sheet and container under the engine.
4. Remove the drain plug **(a)** and allow the oil to drain.

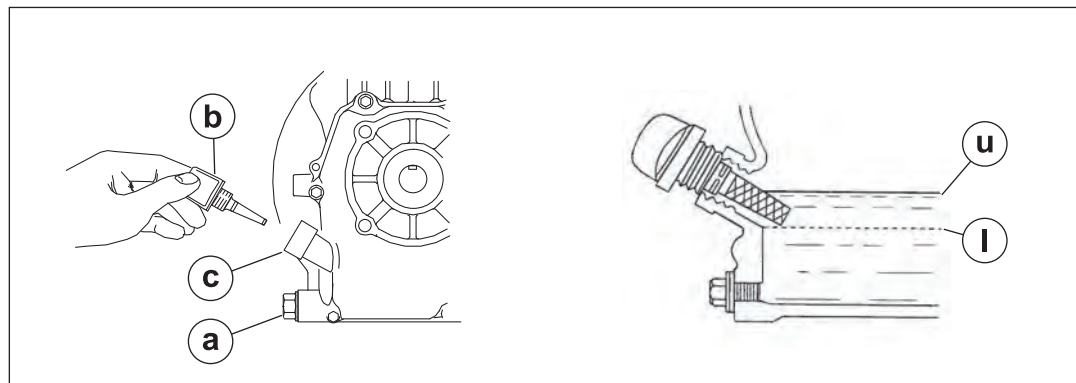

wc_gr007167

5. Re-install the drain plug with a new gasket.
6. Remove the dipstick **(b)** and wipe it clean.
7. Fill the engine crankcase with fresh oil through the filler opening **(c)**. Check the oil level by inserting the dipstick into the filler opening. Do not thread the dipstick into the engine to check the oil level. Fill the crankcase so that the oil level reaches the upper mark on the dipstick.

Note: u = crankcase upper limit; l = crankcase lower limit

8. Re-install the dipstick.

Note: In the interests of environmental protection, dispose of waste oil and soiled rags in accordance with environmental protection legislation.

5.6 Cleaning the Sediment Cup

When Clean the engine sediment cup every 100 hours or 6 months.

Requirements

- Machine shut down
- Nonflammable solvent

Procedure Perform the procedure below to service the sediment cup.

1. Stop the engine.
2. Set the fuel valve to the OFF position.
3. Remove the sediment cup **(a)** and the O-ring **(b)**.

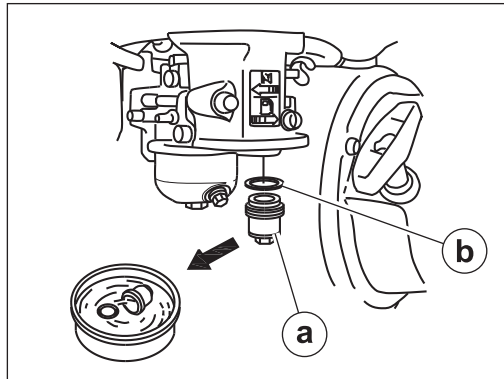

wc_gr007183



WARNING

Fire hazard. Gasoline or low-flash-point solvents are flammable and may ignite if used to clean the machine.

► Use only nonflammable solvents when cleaning the sediment cup.

4. Wash the sediment cup and the O-ring thoroughly in a nonflammable solvent. Dry and re-install them.
5. Set the fuel valve to the ON position and check for leaks.

5.7 Spark Plug

When Clean the spark plug every 100 hours of operation or every 6 months. Replace the spark plug as needed.

Requirements

- Machine shut down
- Engine cool

Procedure Perform the procedure below to clean the spark plug.



WARNING

Burn hazard. The engine and muffler become very hot while running.

► Allow the engine to cool before performing this procedure.

1. Stop the engine and allow it to cool.
2. Remove the spark plug.
3. Inspect the spark plug. Replace the spark plug if the insulator is cracked or chipped, or if the electrode is damaged.
4. Clean the spark plug with a wire brush.
5. Set the electrode gap **(a)**. See chapter *Technical Data* for the recommended gap.

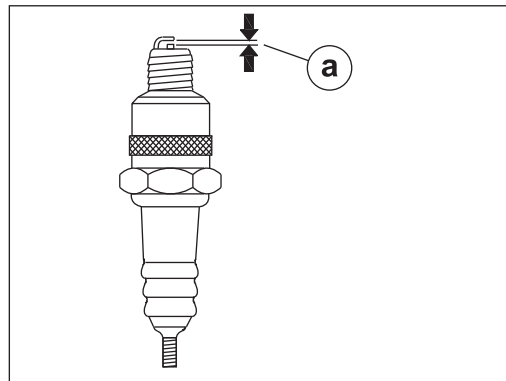

wc_gr007185

6. Re-install the spark plug and tighten it to the recommended torque from the engine owner's manual.

NOTICE: A loose spark plug can become very hot and may cause engine damage.

5.8 Changing the Gearbox Oil

When Change the gearbox oil every 100 hours of operation or every 6 months.

Requirements

- Machine shut down
- Engine warm
- API GL-5 rated gear oil
- Container for used oil

Procedure Perform the procedure below to change the gearbox oil.



WARNING

Burn hazard. The engine and muffler become very while running.

► Stop the engine before performing this procedure.

1. Stop the engine.
2. Remove the drain plug **(a)** and drain the oil into a suitable container.

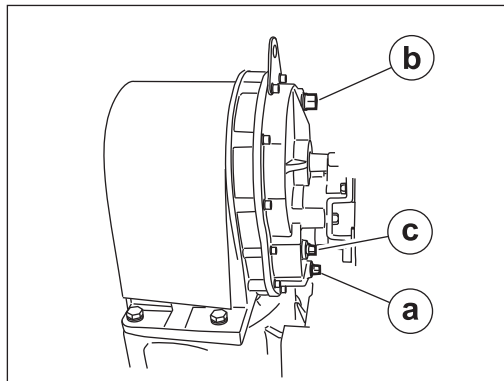

wc_gr007186

3. Re-install the drain plug.
4. Remove the fill plug **(b)** and the level plug **(c)**.
5. Slowly pour gear oil into the fill hole until it comes out of the level hole.
6. Re-install the fill and level plugs.

Note: *In the interests of environmental protection, dispose of waste oil and soiled rags in accordance with environmental protection legislation.*

5.9 Cleaning the Pump

- Requirements**
- Machine shut down
 - Machine cool

Background When pumping heavy sludges or water containing large amounts of dirt and solids, clean the pump often. Materials left in the pump can dry and harden which may lead to damage of the valves or the diaphragm.

Procedure Perform the procedure below to clean the machine.



WARNING

Fire hazard. Gasoline or low-flash-point solvents are flammable and may ignite if used to clean the machine.

- ▶ Do not use flammable solvents to clean the machine.

1. Pump clean water through the pump for a few minutes.
2. Stop the engine and allow the machine to cool.
3. Remove the dirt from in between the engine cooling fins.
4. Remove the pump cover **(a)** and clean dirt and grease build-up from the connecting rod and from the inside of the pump cover.

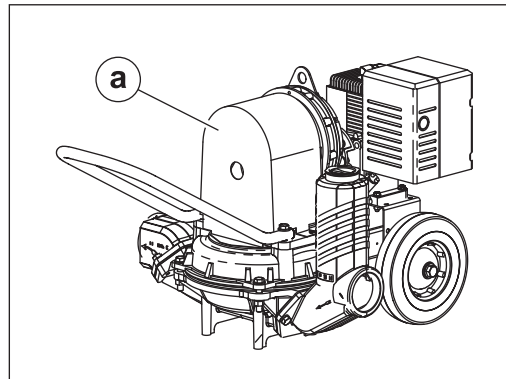

wc_gr007188

5. Re-install the pump cover.

5.10 Storage

Introduction Extended storage of equipment requires preventive maintenance. Performing these steps helps to preserve machine components and ensures the machine will be ready for future use. While not all of these steps necessarily apply to this machine, the basic procedures remain the same.

When Prepare your machine for extended storage if it will not be operated for 30 days or more.

Preparing for storage Perform the procedures below to prepare your machine for storage.

- Complete any needed repairs.
- Replenish or change oils (engine, exciter, hydraulic, and gearcase) per the intervals specified in the Scheduled Maintenance table.
- Grease all fittings and, if applicable, repack bearings.
- Inspect engine coolant. Replace coolant if it appears cloudy, is more than two seasons old, or does not meet the average lowest temperature for your area.
- If your machine has an engine equipped with a fuel valve, start the engine, close the fuel valve, and run the engine until it stops.
- Consult the engine owner's manual for instructions on preparing the engine for storage.

Stabilizing the fuel After completing the procedures listed above, fill the fuel tank completely and add a high-quality stabilizer to the fuel.

- Choose a stabilizer that includes cleaning agents and additives designed to coat/protect the cylinder walls.
- Make sure the stabilizer you use is compatible with the fuel in your area, fuel type, grade and temperature range. Do not add extra alcohol to fuels which already contain it (for example, E10).
- For engines with diesel fuel, use a stabilizer with a biocide to restrict or prevent bacteria and fungus growth.
- Add the correct amount of stabilizer per the manufacturer's recommendations.

Storing the machine Perform these remaining steps to store your machine.

- Wash the machine and allow it to dry.
- Move the machine to a clean, dry, secure storage location. Block or chock the wheels to prevent machine movement.
- Use touch-up paint as needed to protect exposed metal against rust.
- If the machine has a battery, either remove or disconnect it.

NOTICE: Allowing the battery to freeze or completely discharge is likely to cause permanent damage. Periodically charge the battery while the machine is not in use. In cold climates, store and charge the battery indoors or in a warm location.

- Cover the machine. Tires and other exposed rubber items should be protected from the weather. Either cover them or use a readily available protectant.

5.11 Machine Disposal and Decommissioning

Introduction This machine must be properly decommissioned at the end of its service life. Responsible disposal of recyclable components, such as plastic and metal, ensures that these materials can be reused—conserving landfill space and valuable natural resources.

Responsible disposal also prevents toxic chemicals and materials from harming the environment. The operating fluids in this machine, including fuel, engine oil, and grease, may be considered hazardous waste in many areas. Before decommissioning this machine, read and follow local safety and environmental regulations pertaining to the disposal of construction equipment.

Preparation Perform the following tasks to prepare the machine for disposal.

- Move the machine to a protected location where it will not pose any safety hazards and cannot be accessed by unauthorized individuals.
- Ensure that the machine cannot be operated from the time of final shutdown to disposal.
- Drain all fluids, including fuel, engine oil, and coolant.
- Seal any fluid leaks.

Disposal Perform the following tasks to dispose of the machine.

- Disassemble the machine and separate all parts by material type.
- Dispose of recyclable parts as specified by local regulations.
- Dispose of all non-hazardous components that cannot be recycled.
- Dispose of waste fuel, oil, and grease in accordance with local environmental protection regulations.

6 Troubleshooting

Problem	Cause	Remedy
Engine does not start	Engine oil level too low	Add oil to engine.
	Pump housing filled with dirt and debris	Clean pump.
Pump does not prime	Air leak in suction line	Repair or replace suction line.
	Defective flapper valve	Replace the flapper valves.
	Clogged strainer	Clean or replace the strainer.
	No liquid in suction line	Fill the pump and suction line with water.
	Pump housing filled with dirt and debris	Clean pump.
Flow rate is slow	Incorrect engine speed	Check engine speed.
	Hoses are damaged	Replace the hoses.
	Too many bends in the hoses	Straighten the hoses.
	Hoses are too long	Shorten the hoses.
Pump runs but no fluid is pumped	Faulty suction hose	Replace the suction hoses.
	Pump located too far from fluid source	Place the pump closer to the source.
	Flapper valve closed	Clean or replace the flapper valves.
	Clogged strainer	Unclog or replace the strainer.
	Height of discharge hose above pump is too great	Lower the discharge hose.
Pump pumps erratically	Leak in suction hose	Repair or replace the suction hose.
	Diaphragm has crack or hole	Replace the diaphragm.
	Defective or clogged flapper valves	Clean or replace the flapper valves.
Excessive noise while pumping	Pump not secured to firm foundation	Secure the pump.
	Restricted suction hose	Clean or replace the suction hose.

Problem	Cause	Remedy
Water accumulates on top of the diaphragm	Diaphragm has crack or hole.	Replace the diaphragm.
	Screw loose holding diaphragm	Tighten the screw.
Pump stalls repeatedly or stops for no apparent reason	Discharge hose height over 25 feet of head	Lower the discharge hose.
	Pump housing filled with dirt and debris	Clean the pump.

7 Technical Data

7.1 Engine

Engine Power Rating Net power rating per SAE J1349. Actual power output may vary due to conditions of specific use.

Engine		PDI2 / PDT2	PDI3 / PDT3
Type	—	Air-cooled	
Manufacturer	—	Honda	
Model	—	GX120UT2QX2	
Maximum rated power at rated speed	kW/rpm (hp/rpm)	2.6/3600 (3.5/3600)	
Operating speed	rpm	2800	
Displacement	cm ³ (in. ³)	118 (7.2)	
Number of cylinders	—	1	
Oil capacity	ml (oz.)	600 (20)	
Oil type	—	10W30 API SJ, SL or equivalent	
Fuel type	—	Regular unleaded gasoline	
Fuel tank capacity	L (qt)	2.5 (2.6)	
Fuel consumption	L/hr (qt/hr)	1.1 (1.2)	
Running time	hr	2.2	
Spark plug type	—	NGK BPR6HS	
Electrode gap	mm (in.)	0.70–0.80 (0.028–0.031)	

7.2 Pump

Machine		PDI2 / PDT2	PDI3 / PDT3
Suction and discharge hose diameter	mm (in.)	50 (2)	75 (3)
Operating weight	kg (lb)	59 (131)	63 (140)
Maximum discharge head	m (ft)	7.6 (38)	7.6 (38)
Maximum flow rate	L/min (gpm)	189 (50)	333 (88)
Maximum suction lift	m (ft)	6.1 (20)	6.1 (20)
Maximum solid size diameter	mm (in.)	38 (1.5)	41 (1.625)

7.3 Sound Measurements

Products are tested for sound pressure level in accordance with EN ISO 11201:2010.

Sound power level is tested in accordance with European Directive 2000/14/EC - Noise Emission in the Environment by Equipment for use outdoors.

Machine	Sound Pressure at Operator's Location dB(A)	Guaranteed Sound Power dB(A)
PDI2 / PDT2	86	97
PDI3 / PDT3	86	98

7.4 Dimensions

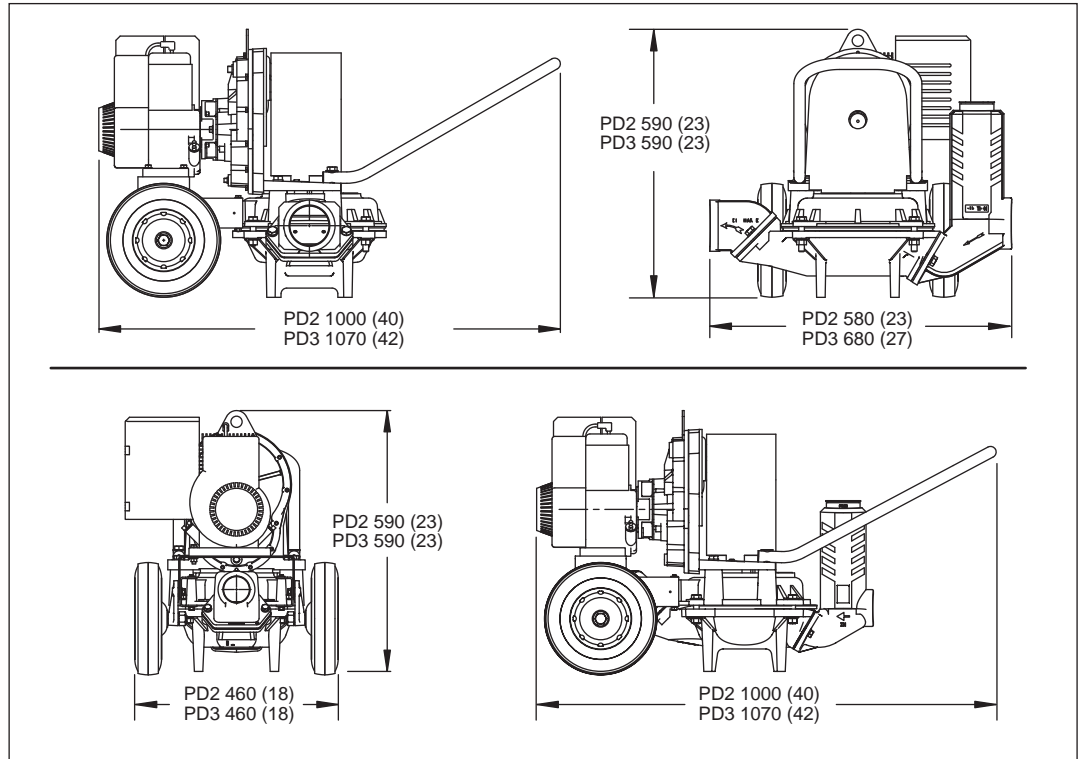

wc_gr007189

Emission Control Systems Information and Warranty

8 Emission Control Systems Information and Warranty

The Emission Control Warranty and associated information is valid only for the U.S.A., its territories, and Canada.

8.1 Emission Control Systems Warranty Statement

See the supplied engine owner's manual for the applicable exhaust and evaporative emission warranty statement.



PORTABLE PUMPS

www.aem.org



SAFETY MANUAL

FOR OPERATING AND MAINTENANCE PERSONNEL

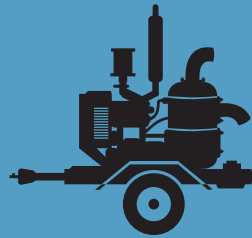
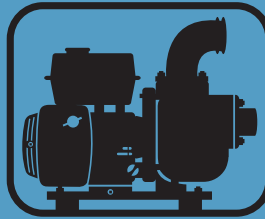

SAFETY ALERT SYMBOL



This Safety Alert Symbol means
ATTENTION is involved!

The Safety Alert Symbol identifies important safety messages on machines, safety signs, in manuals, or elsewhere. When you see this symbol, be alert to the possibility of personal injury or death. Follow the instructions in the safety message.

Why is SAFETY important to YOU?

3 BIG REASONS

- **Accidents KILL or DISABLE**
- **Accidents COST**
- **Accidents CAN BE AVOIDED**

NOTICE OF COPYRIGHT PROTECTION

AEM Safety Manuals are protected as a copyrighted work with ownership duly registered with the Copyright Office, Washington, D.C. Any reproduction, translation, decompiling or other use of an AEM Safety Manual, or portion thereof, or the

creation of derivative works based on an AEM Safety Manual, without the prior written approval of AEM is expressly prohibited. Copyright infringement can result in civil and criminal sanctions, damages and other penalties being imposed.

Copyright © 2004— Association of Equipment Manufacturers

1

REFERENCES

The following is a partial list of referenced material on safe operating practices:

U.S. Department of Labor publishes safety and health regulations and standards under the authority of the Occupational Safety and Health Act for the general construction and mining industries.

U.S. Department of Labor
Washington, DC 20210

NFPA — National Fire Protection Association
P.O. Box 9101
1 Battery March Park
Quincy, MA 02269-9101

SAE — Society of Automotive Engineers, Inc.
400 Commonwealth Drive
Warrendale, PA 15096
Publishes a list, "Operator Precautions" SAE J153
MAY 87.

AEM — Association of Equipment Manufacturers
111 East Wisconsin Avenue
Milwaukee, WI 53202

CONTENTS

	Page	Section
FOREWORD.....	4	
FOLLOW A SAFETY PROGRAM	5	1
PERFORM MAINTENANCE SAFELY	7	2
PREPARE FOR SAFE OPERATION	9	3
WORK SAFELY – Pumps In General	10	4
WORK SAFELY – Engine Driven Pumps.....	13	5
WORK SAFELY – Electric Motor Driven Pumps.....	15	6
WORK SAFELY – Submersibles	17	7
TEST YOUR KNOWLEDGE	19	8
FINAL WORD TO THE USER	20	9

FOREWORD

This safety manual is intended to point out some of the basic situations which may be encountered during the normal operation and maintenance of your equipment, and to suggest possible ways of dealing with these conditions.

Additional precautions may be necessary, depending on application, pump type, configuration and attachments used, conditions at the work-site or in the maintenance area. The manufacturer has no direct control over pump application, operation, inspection, lubrication or maintenance. Therefore, it is your responsibility to use good, safe, practices in these areas.

The information provided in this manual supplements the specific information about your pump that is contained in the manufacturer's manual(s). Other information which may affect the safe operation of your pump may be contained on safety signs, decals, markings, insurance requirements, employer's safety programs, safety codes, local, state/provincial and federal laws, rules and regulations, contracts, agreements and warranties.

It is your responsibility to read and understand this safety manual and the manufacturer's manual(s) before operating your pump. This safety manual takes you step-by-step through your working day. If you do not understand any of this information, or if errors or contradictions seem to exist, consult with your supervisor before operating your pump.

IMPORTANT: If you do not have the manufacturer's manual(s) for your particular pump, get a replacement manual from your employer, equipment dealer, or manufacturer of your pump. Keep this safety manual and the manufacturer's manual(s) with your pump.

Unauthorized modifications of pumps create hazards. Pumps must not be modified or altered unless prior approval is obtained from the manufacturer.

DO NOT PUMP VOLATILE/FLAMMABLE OR CAUSTIC/CORROSIVE LIQUIDS.

REFER TO THE OWNER'S MANUAL OR CONSULT WITH THE MANUFACTURER FOR THE PROPER PUMP MATERIALS IF YOU ARE TO PUMP HAZARDOUS CAUSTIC/CORROSIVE LIQUIDS.

FOLLOW A SAFETY PROGRAM

KNOW THE RULES

Every employer is concerned about safety. Safe operation and proper maintenance of your pump can prevent accidents. **KNOW** the rules — **LIVE** by them. (FIG. 1)

When starting work at a new site, check with the designated safety coordinator for specific safety instructions. **DON'T LEARN SAFETY THE HARD WAY.**

Know the meaning of all hand signals, signal flags, signs and markings.

Know the traffic rules used at the work site. Know who the signal man is; watch and obey his signals.

Know where the fire extinguishers and first aid kits are kept and how to use them. Know where to get proper aid and assistance when needed.

Use common sense to avoid accidents. If an accident does occur, be prepared to react to it quickly and effectively.

NEVER PANIC.

Remember that **YOU are the key to safety.** Good safety practices not only protect you but also protect the people around you. Study this manual and the manufacturer's manual(s) for your specific pump. Make them a working part of your safety program. Keep in mind that this safety manual is written for only this type of equipment. Practice all other usual and customary safe working precautions, and above all (FIG. 1).

REMEMBER — SAFETY IS UP TO YOU
YOU CAN PREVENT
SERIOUS INJURY OR DEATH



FIG. 1

1

5

FOLLOW A SAFETY PROGRAM

KNOW WHAT IT IS?

Consult your supervisor for specific instructions and personal safety equipment required.

For instance, you may need:

- Hard Hat
- Safety Shoes
- Eye Protection
- Respirators
- Heavy Gloves
- Reflector Vests
- Hearing Protection
- Face Protection
- Back Supports
- Other job related specific items

Do not wear loose clothing or any accessory — flopping cuffs, untied shoe-laces, dangling neckties and scarves, rings, wrist watches, or other jewelry — that can catch on protruding or moving parts or controls. Long hair should be securely bound to prevent entanglement with moving parts. (FIG. 3)



FIG. 2



FIG. 3

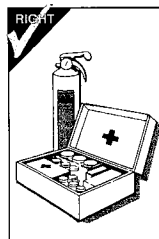

FIG. 4

BE ALERT!

Know where to get assistance. Know how to use a first aid kit and fire extinguisher or fire suppression system. (FIG. 4)

BE AWARE!

Take advantage of training programs offered.

Safety programs should require that one person at each jobsite be assigned the overall responsibility and authority for safety. Know who the person is, and **COMMUNICATE** with them.

Know what the jobsite rules are, and **FOLLOW THE RULES.** Be safety conscious, responsible and reliable. Think about safety **BEFORE** something happens.

BE CAREFUL!

Human error is caused by many factors: carelessness, fatigue, overload, preoccupation, incompatibility between operator and the equipment, drugs, and alcohol to name a few. Damage to the equipment can be fixed in a short period of time, but injury, or death has a lasting effect.

For your safety and safety of others, encourage your fellow workers to act within safety rules.

1

6

PERFORM MAINTENANCE SAFELY

CLOTHING AND PERSONAL PROTECTIVE ITEMS

ALWAYS wear appropriate safety glasses, goggles or face shield when working. (FIG. 2) Proper eye protection can keep flying particles from grinding, drilling or hammering operations, or fluids such as fuel, solvents, lubricants and brake fluids from damaging your eyes. Normal glasses do NOT provide adequate protection.

ALWAYS wear a hard hat and safety shoes. (FIG. 2) ALWAYS wear hearing protectors when exposed to high noise levels for extended periods. ALWAYS wear a respirator when painting or exposed to dusty conditions. ALWAYS keep your pockets free of loose objects which can fall out and drop into machinery. (FIG. 5) Heavy gloves should be worn for many operations.

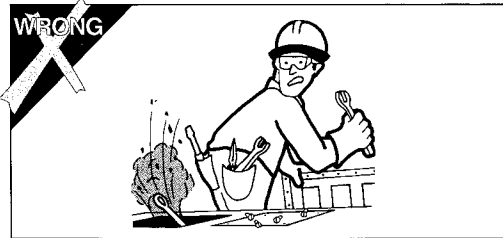

FIG. 5

EXHAUST FUMES

Engine exhaust fumes can cause sickness or death. If it is necessary to run an engine in an enclosed area, remove the exhaust fumes from the area with an exhaust pipe extension. If you do not have an exhaust pipe extension, be positive the area is adequately ventilated. (FIG. 6)

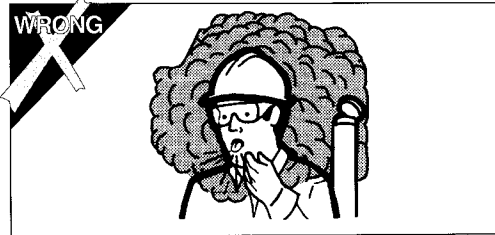

FIG. 6

HEAVY PARTS

Handle tools and heavy parts sensibly — with regard for yourself and other persons. Lower items — don't throw or drop them.

ALWAYS use proper hoisting equipment for lifting heavy loads.

ALWAYS use a back brace when lifting by hand.

2

7

PERFORM MAINTENANCE SAFELY

FIRE PREVENTION

Whenever possible use a nonflammable solvent to clean parts. Do not use gasoline or other fluids that give off harmful vapors.

If flammable fluids, such as gasoline or diesel fuel, must be used, extinguish open flames or sparks and DO NOT smoke.

Store dangerous fluids in a suitable place, in approved containers which are clearly marked. NEVER smoke in areas where flammable fluids are used or stored. (FIG. 7)

Use proper nonflammable cleaning solvents. Follow solvent manufacturer's instructions for use.

Always remove all flammable material in the vicinity of welding and/or burning operations.

ALWAYS keep the floor in the work area clean and dry. Oily, greasy floors can easily lead to falls. Wet spots, especially near electrical equipment, can be hazardous. (FIG. 7)

Know where fire extinguishers are kept — how they operate — and for what type of fire they are intended.

Check readiness of any fire detectors and fire suppression systems.



FIG. 7

2

8

PREPARE FOR SAFE OPERATION

LEARN TO BE SAFE

NEVER operate a pump which is new to you without first being instructed in its proper operation. READ the operator's manual. If one has not been provided, GET ONE AND STUDY IT BEFORE OPERATING THE PUMP.

Know the meaning of all identification symbols on your controls and gauges. (FIG. 8)

Know the location of the emergency shut-down control if the machine is so equipped.

Before attempting to operate the pump, know the capabilities and limitations of the pump. Familiarize yourself with controls and instruments — their locations and functions.

Keep hands, levers and knobs clean of oil or grease to prevent slipping.

Carefully read and follow the instructions on all safety signs and decals on the pump. Keep safety signs in good condition. Replace missing or damaged safety signs.

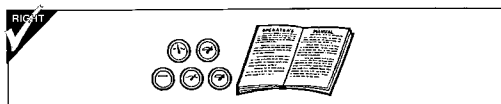

FIG. 8

CHECK IT OUT!

Know what safety devices your machine is equipped with ... and see that each item is securely in place and in operating condition. (FIG. 9)

For example:

- Drawbar Coupling Chains and Pins
- Alarms and Warning Lamps
- Reflectors
- Guards and Shields
- Drain Covers, Plugs, and Caps
- Shut-Down Devices
- Leveling Jacks
- Pressure Relief Devices
- Lifting Devices



FIG. 9

NEVER START OR OPERATE A PUMP KNOWN OR SUSPECTED TO BE DEFECTIVE OR MALFUNCTIONING.

If your daily check uncovers any items that need attention — repair, replacement, or adjustment — report them promptly. The most minor malfunction could be the result of more serious trouble — or can cause it, if pump is operated. When in doubt, attach an OSHA Lockout/Tagout device tag to the control panel to disconnected electrical power supply at breaker, on electrically driven pumps and disconnect the battery and/or spark plug wire on engine driven pumps.

3

9

WORK SAFELY — Pumps In General

SAFE WORKING PROCEDURES

USE COMMON SENSE! Most accidents can be avoided by using common sense and concentrating on the job to be done.

ONLY EXPERIENCED AND QUALIFIED personnel should install and operate pump equipment.

KNOW THE PROPER starting procedure for your equipment. Follow the manufacturer's operation manual ... to the letter.

DO NOT operate a pump without all guards and shields in place. (If OSHA required guards are damaged or misplaced, contact the manufacturer for a replacement.)

When **lifting pump** use only lifting equipment in good repair and with adequate capacity. Follow manufacturer's lifting recommendation.

Check all lubricant levels before pump installation in accordance with manufacturer's maintenance programs.

Keep hands and feet clear of moving parts. DO NOT stick fingers into a pump when in operation. Check suction strainer and hose regularly for proper submergence and to be sure it is free of obstructions.

NEVER operate a self-priming pump unless the volute is filled with liquid. The pump will not prime when dry.

PUMP only liquids for which the pump has been designed to handle.

DO NOT pump flammable, corrosive or caustic materials unless the pump and piping are explicitly designed for that purpose.

NOTE the direction of rotation — operation of a pump in the wrong direction can cause the impeller to unscrew and damage the volute case.

A pump should not be operated against a closed valve or other no flow conditions. Refer to the pump manufacturer's recommended practice for start-up, operation and shut-down procedures. **DO NOT** close down or restrict a discharge hose. **Be careful** of discharge hose whipping under pressure.

4

WORK SAFELY – Pumps In General

MAKE CERTAIN that whatever is to be connected to the pump is not subjected to pressures greater than those given in the manufacturer's instructions.

MAKE CERTAIN all connections are securely made and hoses under pressure are secured, with appropriate safety devices, to prevent whipping.

BE AWARE OF LIGHTNING. Stay clear of the pumping equipment during electrical storms. It can attract lightning. (FIG. 10)

OVERHEATING PRECAUTIONS

Overheated pumps can cause severe damage to the equipment and can cause severe physical burns and injury.

Operating a pump with the suction and/or discharge valve closed is a principal cause of overheating. Approach cautiously any pump that has been in operation.

DO NOT remove hoses from a pump until the system is properly cooled to ambient temperature.

DO NOT remove the cover plate or drain plugs from any overheated pump. Allow the pump to cool. Check pump temperature before opening fill port or drain plug.

If overheating of the pump casing occurs:

- **STOP** the pump immediately.
- Allow the equipment to **cool completely**.
- Slowly and cautiously **vent the pump**.
- **Refer to the manufacturer's instruction manual** before restarting the unit.
- Remove hoses carefully. Heated water can be in hoses and static head produces pressure.

4

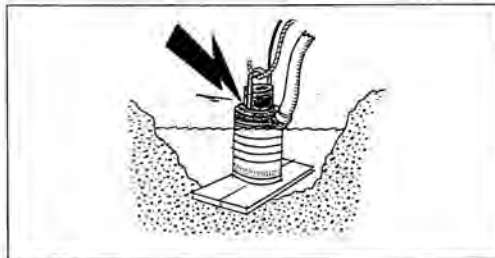

FIG. 10

11

WORK SAFELY – Pumps In General

BEFORE STARTING

Check the pump thoroughly at delivery for any shipping damage.

Locate the pump in an accessible location, as close to the liquid as possible.

Secure the pump after it is placed in its intended operating position so it does not tip, roll, slide or fall.

IMMEDIATELY ON STARTING THE PUMP

Observe gauges, instruments and warning lights to ensure that they are functioning and their readings are within the normal operating range.

- Be sure the immediate work area is safe for operation.
- Operate controls; make certain all operate properly and "feel" right. Accustom yourself to the "feel" of the equipment.
- Listen for any unusual noises, smell for any unusual odors; look for any signs of trouble.
- Be sure to open all manual valves slowly to prevent WATER HAMMER.
- Check all warning and safety devices and indicators.

• If safety-related defects or malfunctions are detected, **SHUT DOWN** the equipment. Correct the problem, or notify your supervisor. **DO NOT OPERATE EQUIPMENT WITH DEFECTS OR MALFUNCTIONS UNTIL CORRECTED.**

• **If an unsafe condition cannot be remedied immediately, notify your supervisor and tagout/lockout** the pump on the start switch and/or appropriate, prominent location. (FIG. 11)

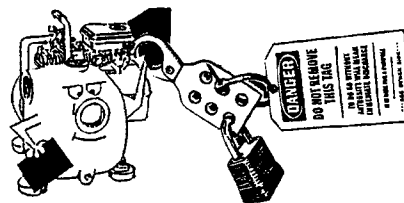

FIG. 11

4

WORK SAFELY – Engine Driven Pumps

SAFE WORKING PROCEDURES

Do not jump start engine battery.

When operating internal combustion engines in an enclosed area, always make provisions to pipe exhaust fumes to the outside.

EXHAUST FUMES CAN KILL: Do not operate engine driven pump equipment in a confined or enclosed space without adequate ventilation.

Exhaust gases are odorless and deadly poison.

DO NOT TOUCH: The exhaust system components get very hot and stay hot for some time after shutting the engine off.

Follow engine manufacturer's instructions explicitly on hand cranking.

Do not shut down high head pumps quickly:

- A) Throttle back slowly
- B) Open by-pass line
- C) Should have a check valve
- D) Slowly close gate valve on discharge if so equipped.

Check for fuel, oil and hydraulic fluid leaks, worn and damaged hoses/lines or power cables.

Refueling

When refueling, the following precautions must be followed:

- Add fuel of proper type and grade, only when the pump is not running and engine is cool.
- Fuel in well ventilated area.
- Turn off all electrical switches.
- Keep lighted smoking materials, flames or spark producing devices at a safe distance while refueling.
- Keep fuel nozzle in contact with tank being filled, or provide a ground to prevent static sparks from igniting fuel.
- **Do not spill fuel on hot surfaces.**
- Clean up spillage immediately.
- Do not start engine until fuel cap is secured to the fuel tank.
- **Always** make sure that fuel is being put in the fuel tank, motor oil in the proper location and hydraulic oil into hydraulic oil reservoirs.

5

13

WORK SAFELY – Engine Driven Pumps

Maintenance and Repair

All installations, operations and maintenance should be in accordance with pump and engine manufacturer's recommended operation and maintenance program. These manuals should be kept available with the equipment.

Maintenance work can be **hazardous** if not done in a careful manner. All personnel should realize the hazards and strictly follow safe practices.

NEVER perform any work on the equipment unless authorized to do so.

BEFORE ANY maintenance **work** is to be done, a LOCKOUT/TAGOUT standard device and procedure should be implemented. Prior to removal of LOCKOUT/TAGOUT, the equipment must be fully operational and all personnel accounted for. Except in cases of emergency, the removal of the LOCKOUT/TAGOUT should be done **ONLY** by the initiating person prior to the return to start-up (see page 12, Fig. 11).

BEFORE doing any major work, disconnect the ignition and battery if so equipped.

Always replace safety devices removed during service or repair before returning pump to operation.

Battery Servicing

- **Always wear** safety glasses and gloves when servicing or working with batteries.
- **Before servicing battery**, turn off electrical systems, then disconnect ground terminal clamp. Before installing a battery, turn off electrical equipment, then connect the battery ground clamp **last**.
- **Maintain** electrolyte at the recommended level. Check level frequently. Add distilled water to batteries only when starting up, never when shutting down.
- **Use a flashlight** to check level. **NEVER** use a flame.
- **Do not short** across battery terminals — the spark could ignite the battery gases.

Battery acids will **burn skin**, eat holes in clothing, and can **cause blindness** if splashed in eyes.

If you spill acid on yourself flush skin immediately with lots of water. Apply baking soda to help neutralize the acid. If acid gets into the eyes, flush immediately with large amounts of water and seek proper medical treatment immediately.

5

14

WORK SAFELY – Electric Motor Driven Pumps

SAFE WORKING PROCEDURES

Allow only qualified personnel to INSTALL, WIRE AND OPERATE electric motor driven pumps. Whenever electricity is present there is the possibility of **electrocution**.

NEVER use a pump/motor in an explosive atmosphere if it is not exclusively designed for the application.

Always ground electrical units.

Make certain to connect pump motor to the right phase and voltage.

Do not run pump if voltage is not within limits.

Make sure motor rotation is in accordance with impeller rotation (which should be indicated somewhere on the pump — check the manufacturer's manual).

Make all electrical installations in accordance with National Electric Code, State and Local electrical codes.

Never use gas piping as an electrical ground.

Make sure the related electrical circuits are dead and locked out before performing any maintenance.

Follow motor manufacturer's recommended maintenance and operation instructions.

If circuit breaker or fuse is tripped, examine the system for the problem before restarting pump.

NEVER use the power cord to aid lifting the pump.

NEVER operate a pump with a plug-in type power cord without a ground fault circuit interrupter.

NEVER use cords with frayed, cut or brittle insulation. Check the cord on the pump for nicks in the insulation and for sound connections to the ground fault interrupter plug and motor.

NEVER let extension cords or the plug connections lay in water. Locate the pump so that the cord cannot fall into any water or be submerged by rising water, unless the pump is designed for such use.

NEVER handle energized power cords with wet hands.

MOTOR OVERLOAD: do not exceed the manufacturer's recommendation for maximum lift or discharge head. See manufacturer's published curve for proper sizing of motors. A misapplied motor can overheat.

6

15

WORK SAFELY – Electric Motor Driven Pumps

Pump Maintenance and Repair

MAKE SURE the pump is disconnected from the power source or the appropriate circuits are dead and OSHA Lockout/Tagout is applied before doing any maintenance or repair work on the pump.

Maintenance work can be **hazardous** if not done in a careful manner. All personnel should realize the hazards and strictly follow safe practices.

NEVER perform any work on the equipment unless authorized to do so. (FIG. 11) Before performing any maintenance or repair work, consult the manufacturer's instruction manual for recommended procedures.

Pumps with float switches or other automatic devices can start without warning if not properly locked out.

BEFORE ANY maintenance work is to be done, a LOCKOUT/TAGOUT standard device and procedure should be implemented. Prior to removal of LOCKOUT/TAGOUT, the equipment must be fully operational and all personnel accounted for. Except in cases of emergency, the removal of the LOCKOUT/TAGOUT should be done **ONLY** by the initiating person prior to the return to start-up.

ALWAYS replace safety devices removed during the service or repair before returning pump to operation.

NEVER use the power cord to aid in lifting the pump.

Sizing Extension Cords

Use the following chart to select the correct size extension cord to prevent excessive amperage draw or voltage drop which would cause the motor to overheat. **Cables that are too long or coiled** can cause a voltage drop. **Be aware** that strong sunlight can cause a voltage drop.

Amperes	Wire Gauge and Cord Length (in feet)		
	50	100	150
6	16	16	14
8	16	14	12
10	16	14	12
12	14	14	12
14	14	12	10
16	12	12	10

6

WORK SAFELY – Submersibles

SAFE WORKING PROCEDURES

ALLOW only qualified personnel to INSTALL, WIRE and OPERATE submersible pumps.

Whenever electricity is present there is the possibility of **electrocution**.

NEVER use a pump/motor in an explosive atmosphere, if it is not exclusively designed for that application.

ALWAYS ground the pump.

Make certain to connect the pump to the right phase and voltage.

DO NOT run the pump if voltage is not within limits. **Make all electrical installations** in accordance with National Electric Code, State and Local electrical codes.

Mount electrical control box in a vertical position, protected from the elements.

NEVER attempt to use the power cord or hydraulic hoses as a lifting or lowering device for submersibles. Attach a lifting cable to the manufacturer's recommended attachment point on the pump for lowering and lifting the pump. (FIG. 12)

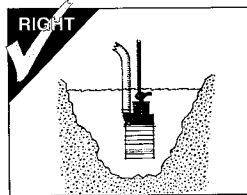

FIG. 12

NEVER position the pump directly on a soft, loose bottom. To attain maximum capacity and prevent excessive wear, position the pump so it will not burrow itself into sand or clay. Stand the pump on a plank, a bed of coarse gravel, within a perforated container, on a suitable floatation device, or retain it hanging freely by a lifting cable. (FIG. 13)

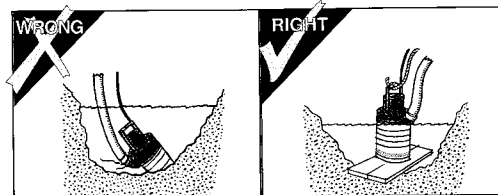

FIG. 13

7

17

WORK SAFELY – Submersibles

Pump Maintenance and Repair

MAKE SURE the pump is disconnected from the power source or the appropriate circuits are dead and OSHA Lockout/Tagout is applied before doing any maintenance or repair work on the unit.

Maintenance work can be **hazardous** if not done in a careful manner. All personnel should realize the hazards and strictly follow safe practices.

NEVER perform any work on the equipment unless authorized to do so. Before performing any maintenance or repair work, consult the manufacturer's instruction manual for recommended procedures.

BEFORE ANY maintenance work is to be done, a LOCKOUT/TAGOUT standard device and procedure should be implemented. Prior to removal of LOCKOUT/TAGOUT, the equipment must be fully operational and all personnel accounted for. Except in cases of emergency, the removal of the LOCKOUT/TAGOUT should be done **ONLY** by the initiating person prior to the return to start-up.

Check oil level ONLY when pump is cool.

USE ONLY recommended oil per manufacturer's recommendation.

INSPECT ELECTRICAL WIRING for worn or damaged insulation. **INSTALL** new wiring if wires are damaged. **After repairs are made, clean the equipment before putting the pump back into position.**



7

TEST YOUR KNOWLEDGE

Do you understand this AEM SAFETY MANUAL AND ITEMS SUCH AS ...

- Your safety program?
 - Your pump manufacturer's manual(s)?
 - Proper clothing and personal safety equipment?
 - Your pump's controls, warning signs and devices, and safety equipment?
 - How to properly inspect, mount, and start your pump?
 - How to check your pump for proper operation?
 - Your work area and any special hazards that may exist?
- Proper operating procedures?
 - Proper shutdown procedures?
 - Proper maintenance procedures?
 - Proper loading and unloading procedures for transporting?
 - Under what conditions you should not operate your pump?

If you do not understand any of these items, consult with your supervisor BEFORE operating your equipment!

8

19

FINAL WORD TO THE USER

Remember that **YOU are the key to safety**. Good safety practices not only protect you but protect the people around you.

You have read this safety manual and the manufacturer's manual(s) for your specific pump. Make them a working part of your safety program. Keep in mind that this safety manual is written for only this type of equipment.

Practice all other usual and customary safe working precautions, and above all —

**REMEMBER
SAFETY IS UP TO YOU
YOU CAN PREVENT SERIOUS
INJURY OR DEATH**

9

20

This manual is another in a series on the safe operation of machinery published by AEM.
For additional publications visit our web site at www.aem.org.



Association of Equipment Manufacturers

Toll free 1-866-AEM-0442

e-mail aem@aem.org

www.aem.org

Important: For spare parts information, please see your Wacker Neuson Dealer, or visit the Wacker Neuson website at <http://www.wackerneuson.com/>.

Wichtig! Informationen über Ersatzteile erhalten Sie von Ihrem Wacker Neuson Händler oder besuchen Sie die Wacker Neuson Website unter <http://www.wackerneuson.com/>.

Important : Pour des informations sur les pièces détachées, merci de consulter votre distributeur Wacker Neuson, ou de visiter le site Internet de Wacker Neuson sur <http://www.wackerneuson.com/>.

Importante : Para saber más sobre las piezas de repuesto, póngase en contacto con su distribuidor de Wacker Neuson o acceda al sitio web de Wacker Neuson en <http://www.wackerneuson.com/>.

Importante : Per informazioni sui pezzi di ricambio, contattare il rivenditore Wacker Neuson o visitare il sito di Wacker Neuson all'indirizzo www.wackerneuson.com.

Viktigt : För information om reservdelar, kontakta din Wacker Neuson-leverantör eller besök Wacker Neusons webbplats på <http://www.wackerneuson.com/>.

Tärkeää : Pyydä varaosatietoja Wacker Neusonin jälleenmyyjältä tai vieraile Wacker Neusonin web-sivustolla osoitteessa <http://www.wackerneuson.com/>

Viktig : For informasjon om reservedeler, vennligst kontakt din Wacker Neuson-forhandler, eller besøk Wacker Neusons nettside på <http://www.wackerneuson.com/>.

Viktigt : Hvis du ønsker opplysninger om reservedele, bedes du kontakte din Wacker Neuson forhandler eller besøg Wacker Neuson websiden på <http://www.wackerneuson.com/>.

Belangrijk! Neem contact op met uw Wacker Neuson dealer of bezoek de website van Wacker Neuson op <http://www.wackerneuson.com/> voor meer informatie over reserveonderdelen.

Importante : Para obter informações sobre as peças sobresselentes, consulte o seu fornecedor da Wacker Neuson ou acesse ao site Web da Wacker Neuson em http://www.wackerneuson.com

Ważne : W celu uzyskania informacji na temat części zamiennych skontaktuj się z przedstawicielem firmy Wacker Neuson lub skorzystaj z witryny internetowej <http://www.wackerneuson.com/>.

Důležitě upozornění! Pro informace o náhradních dílech, prosím, kontaktujte svého Wacker Neuson dealera, nebo navštivte webové stránky <http://www.wackerneuson.com/>.

FONTOS: A pótalkatrészekre vonatkozó információkért kérjük, forduljon Wacker Neuson kereskedőjéhez vagy látogasson el a Wacker Neuson weboldalára a következő címen: <http://www.wackerneuson.com/>.

Важно! Для ознакомления с информацией о запасных частях, пожалуйста, обратитесь к местному торговому представителю компании Wacker Neuson или посетите веб-сайт <http://www.wackerneuson.com/>.

Σημαντικό : Για πληροφορίες σχετικά με τα ανταλλακτικά, μιλήστε με τον αντιπρόσωπό σας της Wacker Neuson, ή επισκεφθείτε τον ιστότοπο <http://www.wackerneuson.com/>.

Važno : Za rezervne dijelove obratite se svom Wacker Neuson prodavaču ili posjetite mrežne stranice tvrtke Wacker Neuson: <http://www.wackerneuson.com/>.

Önemli : Yedek parça bilgileri için Wacker Neuson Bayinize bakın veya Wacker Neuson web sitesini ziyaret edin. <http://www.wackerneuson.com/>

重要 交換部品の情報については、ワッカーノイゾンディーラーにお問い合わせ頂くか、ワッカーノイゾンウェブサイト <http://www.wackerneuson.com/> をご覧ください。

重要 有关备件信息，请咨询您的威克诺森经销商或访问威克诺森网站：
<http://www.wackerneuson.com/>。

Important : Pentru informații referitoare la piesele de schimb, vă rugăm să vă adresați distribuitorului Wacker Neuson sau să vizitați site-ul web Wacker Neuson la adresa <http://www.wackerneuson.com/>.

Важно : За информация относно резервни части, моля, обърнете се към местния дилър на Wacker Neuson или посетете уебсайта на Wacker Neuson на адрес <http://www.wackerneuson.com/>.

Wacker Neuson Produktion GmbH & Co. KG, Preußenstraße 41, D-80809 München,

Tel.: +49-(0)89-3 54 02-0 Fax: +49 - (0)89-3 54 02-390

Wacker Neuson Production Americas LLC, N92W15000 Anthony Ave., Menomonee Falls, WI. 53051

Tel.: (262) 255-0500 Fax: (262) 255-0550 Tel.: (800) 770-0957

Wacker Neuson Limited - Room 1701-03 & 1717-20, 17/F. Tower 1, Grand Century Place, 193 Prince Edward Road West, Mongkok, Kowloon, Hongkong. Tel: (852) 3605 5360, Fax: (852) 2758 0032