



LIGHTED BOXES

with PowerSync™ Technology

INSTALLATION MANUAL

LIGHTED BOXES with PowerSync™ Technology

ATTENTION: PLEASE READ AND UNDERSTAND ALL INSTRUCTIONS AND WARNINGS BEFORE ASSEMBLING, INSTALLING OR USING THIS PRODUCT.

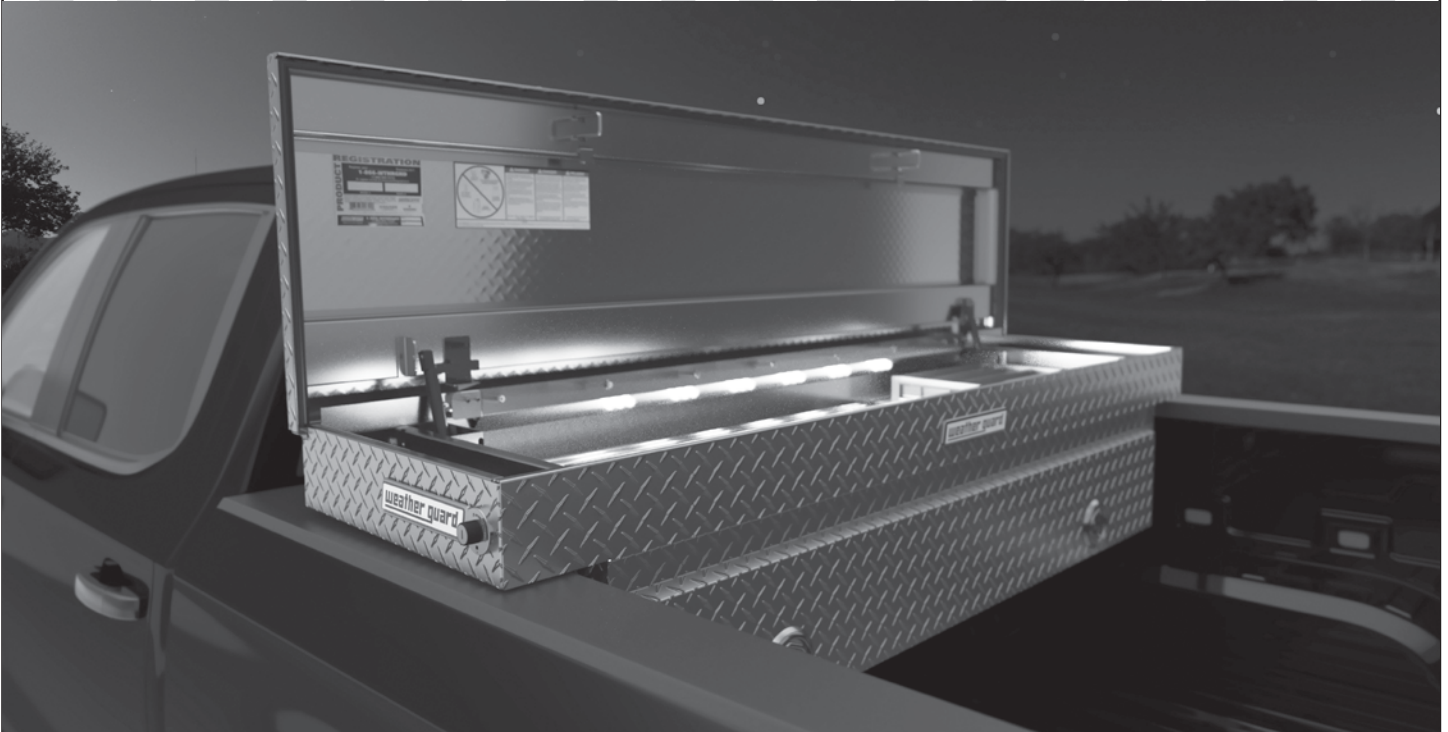

This installation manual covers the following Weather Guard models:

- **Weather Guard Lighted Saddle Box models**
 - **127-0-02LB**, Weather Guard Lighted Saddle Box, Clear color, no wiring harness (separate purchase)
 - **127-52-02LB**, Weather Guard Lighted Saddle Box, Textured Matte Black, no wiring harness (separate purchase)
- **Weather Guard Lights Upgrade kits for 127-X-02 or 117-X-02 boxes**
 - **827-0-02LB**, Weather Guard Lighted Accessory, Clear color, for Weather Guard 127-0-02 or 117-0-02, no wiring harness (separate purchase)
 - **827-52-02LB**, Weather Guard Lighted Accessory, Matte Black color, for Weather Guard 127-52-02/127-5-02 or 117-52-02/117-5-02, no wiring harness (separate purchase)
- **Wiring Harness (to be purchased separately from 127-X-02LB or 827-X-02LB SKUs)**
 - **827WF**, Wiring Harness, Fuse Box
 - **827WS**, Wiring Harness, Standard

If you are installing Weather Guard Lighted Box (127-xx-LB), only one of the wiring harness installation is applicable based on the vehicle you are installing (check the compatibility table on next page).

For installing the Weather Guard Lights Upgrade kit (827-xx-LB), please follow one of the wiring harness installation section that is applicable for your vehicle and the Lights Upgrade Kit installation (Section 3) of the instruction manual.

⚠ NOTICE: Before you start the installation, please make sure to park the truck on a level surface, turn off the truck engine, and remove the key from the ignition.

For installation of the truck box to the truck bed, please reference the Weather Guard saddle box installation manual, included in the separate accessory/installation kit box with your truck box.

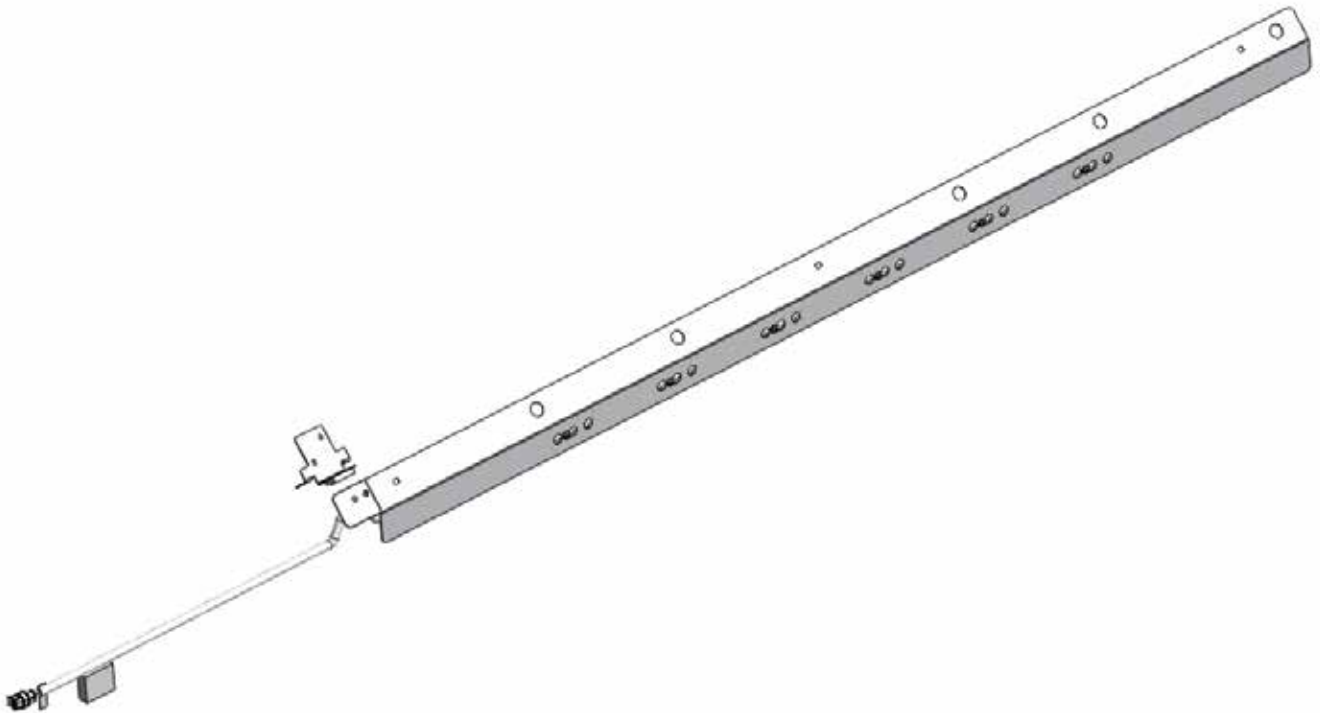

Table 1: Weather Guard Lighted Saddle Box Vehicle Compatibility

(For 2009 and newer truck models)

Make	Model	127-X-02LB	827WF	827WS
Chevrolet **	Silverado 1500	X		X
	Silverado 2500	X		X
	Silverado 3500	X		X
GMC **	Sierra 1500	X		X
	Sierra 2500	X		X
	Sierra 3500	X		X
Dodge **	Ram 1500	X		X
	Ram 2500	X		X
	Ram 3500	X		X
Ford	F150	X	X	
	F250	X	X	
	F350	X	X	
Nissan	Titan	X	X	
Toyota	Tundra	X	X	

**Chevrolet/GMC/Dodge trucks with the factory trailer towing package. For Chevrolet/GMC/Dodge trucks without the factory trailer towing package, use 827WF models

Table 2: Weather Guard 127-X-02 & 117-X-02 Saddle Box Lights Upgrade Kit Vehicle Compatibility

(For 2009 and newer truck models)

Make	Model	827-X-02LB	827WF	827WS
Chevrolet **	Silverado 1500	X		X
	Silverado 2500	X		X
	Silverado 3500	X		X
GMC **	Sierra 1500	X		X
	Sierra 2500	X		X
	Sierra 3500	X		X
Dodge **	Ram 1500	X		X
	Ram 2500	X		X
	Ram 3500	X		X
Ford	F150	X	X	
	F250	X	X	
	F350	X	X	
Nissan	Titan	X	X	
Toyota	Tundra	X	X	

**Chevrolet/GMC/Dodge trucks with the factory trailer towing package. For Chevrolet/GMC/Dodge trucks without the factory trailer towing package, use 827WF models

Section 1: Installation of a Standard Wiring Harness via the Towing Plug

(For Late Model Chevrolet, GM or Dodge Ram Pickup Trucks with the factory trailer towing package only)

1. Connect New Truck Box Harness to Truck

- a. Locate the factory wiring for towing plug/7 pin connector under or behind the rear bumper of your truck. Disconnect the 7-pin connector from the back of the plug. Please note that there is likely a locking tab that needs to be depressed in order to unplug it. Plug the new harness socket into the back of the plug and then the towing plug into the other plug in the new harness.

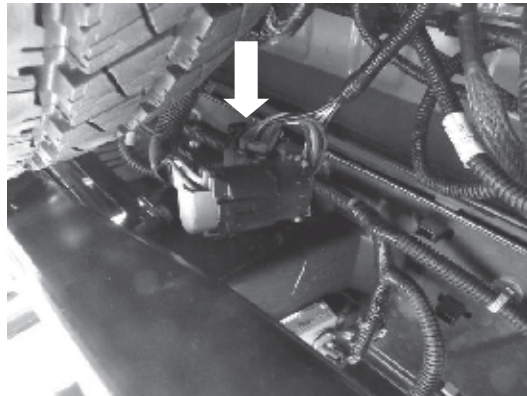

- b. Tuck in and secure the trailer hitch wiring harness to the bumper, bed, or existing factory wiring harness using a zip tie.

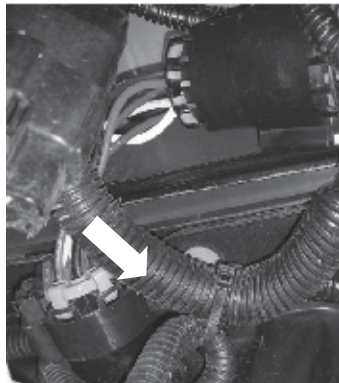

2. Route Harness to Truck Bed

- a. Route the new harness between the rear bumper and the knock out hole in the front of the truck bed. It is usually easiest to follow the path of an existing wiring harness along the frame of the truck (recommend driver side). Secure the new harness to the truck in a few locations using the zip ties supplied.

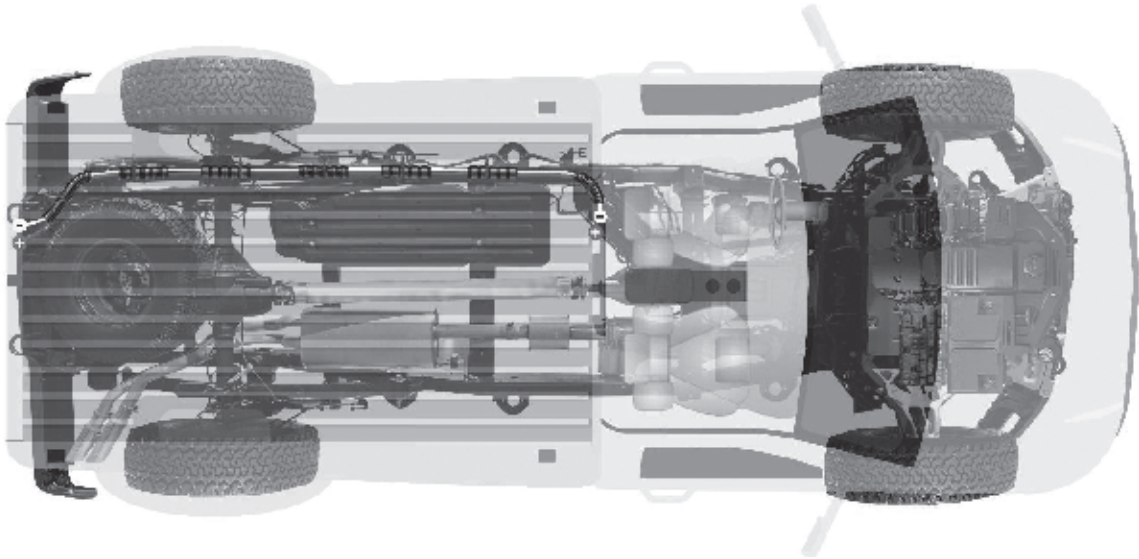

3. Route Harness Into the Truck Box and Connect

- a. Remove the knock-out plug from the back of the truck bed, feed the harness end into the truck bed and then through the grommet in the side of the truck box. Inside the truck box, connect the 2 pin connector to the light bar and tuck the excess wiring inside the gas spring guard.

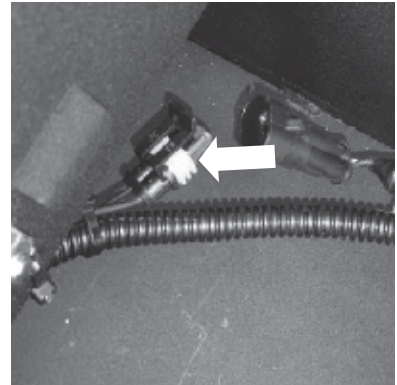
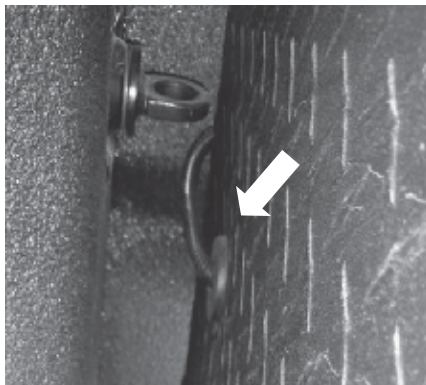

4. Check the Functionality

- a. With the lid open, LEDs should be lit. Close the lid approximately $\frac{3}{4}$ of the way and confirm LED lights turn off.

Section 2: Installation of a Fuse Box Wiring Harness on a Pickup Truck

(For Late Model Ford, Toyota, or Nissan Pickup Trucks. Additionally, this wiring harness works for any Chevrolet, GMC, or Dodge pickup trucks without the factory trailer towing package.)

1. Determine a Fuse Slot to Use

- a. Identify an open fuse slot in the under-the-hood fuse box that will provide constant power (battery power). For easier installation, review the vehicle owners' manual to locate the horn fuse (or any other always powered accessory) and utilize the open slot in the same row as that fuse.

2. Disconnect Battery

- a. Disconnect the negative terminal from the truck's battery.

3. Connect New Truck Box Harness to Truck Fuse Box and Ground

- a. If you are utilizing a slot currently in use - as in the case of the horn slot - remove the existing fuse (select the fuse with 10 amp or less in rating) and insert it into the lower fuse slot on the fuse end of the harness. Plug the fuse end of the harness into the selected slot.
- b. If you are utilizing a slot currently NOT in use, plug in the fuse connector end of the harness into the selected slot. Please note, if the fuse slot is not programmed to provide constant power, no power will reach the truck box.
- c. Attach the white ground wire from the harness to an existing ground near the fuse box.

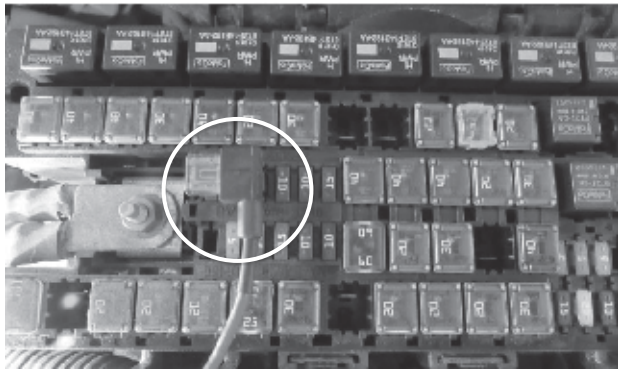

4. Route Harness to Truck Bed

- a. Route the new harness inside the truck body between the fuse box and the knock out hole in the front of the truck bed. It is recommended to follow the path of an existing vehicle wiring harness along the frame of the truck (recommend driver side). Secure the new harness to the truck in a few locations using the zip ties supplied.

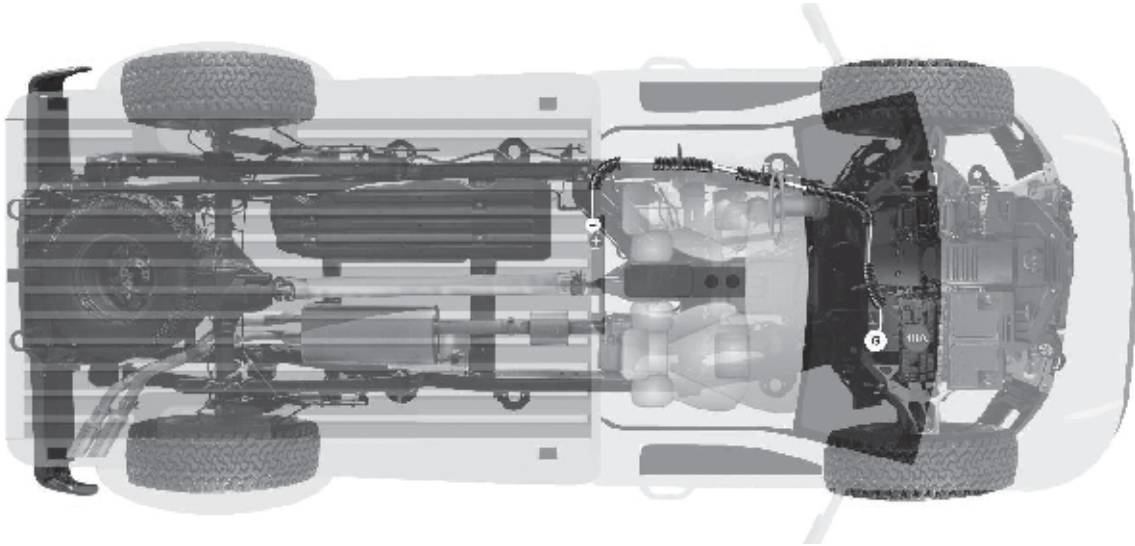

5. Route Harness Into the Truck Box and Connect

- a. Remove the knock-out plug from the back of the truck bed, feed the harness end into the truck bed and then through the grommet in the side of the truck box. Inside the truck box, connect the 2 pin connector to the light bar and tuck the excess wiring inside the gas spring guard.

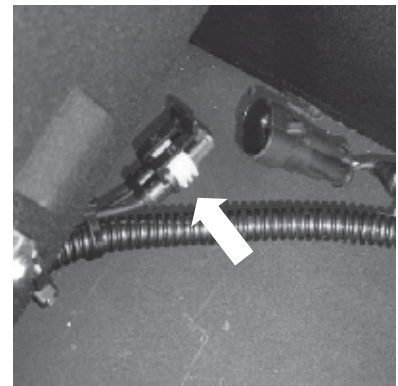
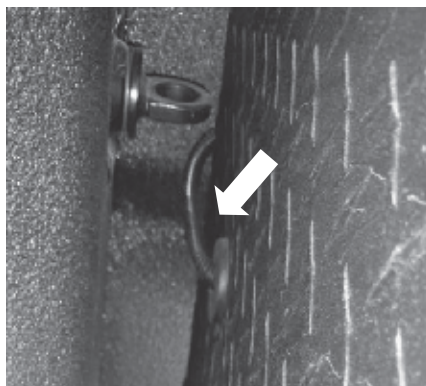

6. Reconnect Battery

- a. Reconnect the negative terminal from the truck's battery.

7. Check the Functionality

- a. With the lid open, LEDs should be lit. Close the lid approximately $\frac{3}{4}$ of the way and confirm LED lights turn off. If the lights do not light or do light but go out suddenly soon after, the fuse slot you have used is not providing constant power and you will need to switch the fuse plug to different slot location in the fuse box to one that does.

Section 3: Installation of a Lights bar assembly to the 127-X-02 or 117-X-02 Box

Tools needed:

- 3/8" & 1/4" socket with socket wrench
- Power Drill with a socket driver adapter
- 1/8" Drill bit (optional)

1. Remove Three Lid Bolt Nuts

- Remove the 2nd, 5th and 8th nuts, left to right, from the box lid bolts and save them for later.

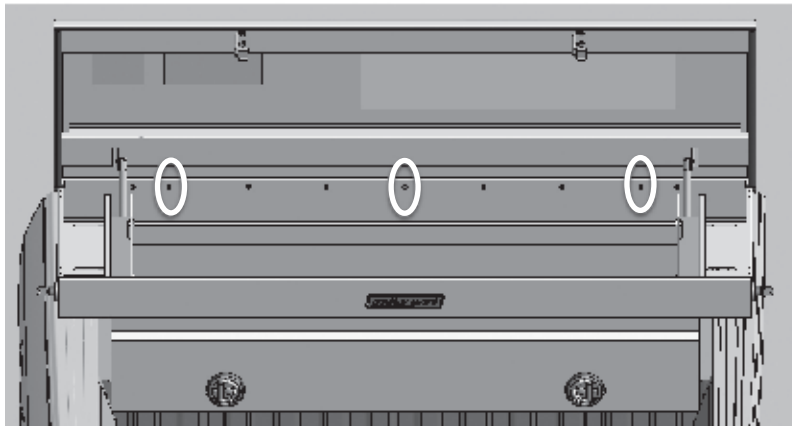

2. Bolt the Light Bar to the Box

- Align the truck light assembly to the box as shown with the wiring to the left side and re-install the nuts bolting the light assembly in place. Make sure that the wiring harness on the left side is tucked safely underneath the light bar prior to tightening the three nuts. Route the end of the wire harness behind the gas spring guard.

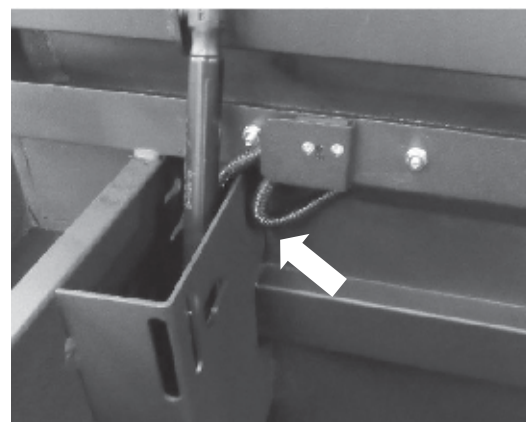
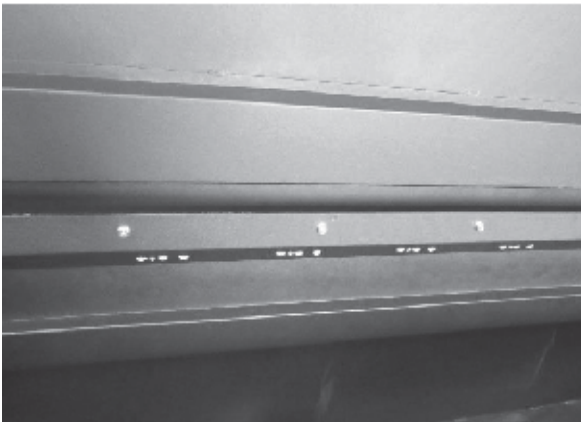

3. Attach the Magnet Bracket

- a. Place the magnet bracket against the bottom lid channel, aligned to the magnetic switch on the light bezel, on the left side as shown below making sure that the bracket tabs stay flush with the bottom of the channel. If there are predrilled mounting holes in the channel, align the mounting holes in the bracket with the two lower predrilled holes.
- b. If there are no predrilled holes in the channel, align the magnet bracket with the magnet on the light assembly as shown. Note: Using a piece of tape to temporarily hold the bracket in place will make the installation of the screws easier. Install the two self-tapping screws, using $\frac{1}{4}$ " driver & drill, through the mounting holes in the magnet bracket to secure the bracket assembly in place. You can also predrill the holes, with the $\frac{1}{8}$ " bit, for easier installation.

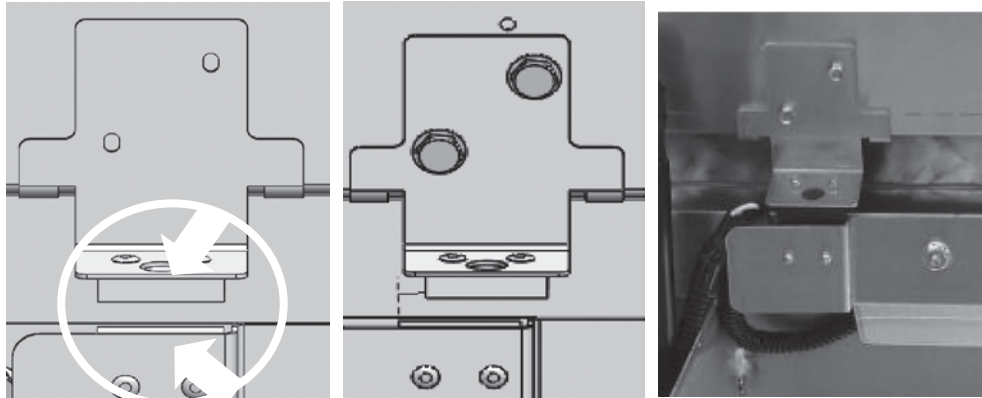

4. Check for Interference

- a. Slowly open and close the lid and check for any interference. There shouldn't be any interference between Magnet bracket and Light assembly for proper operation.

5. Check the Functionality

- a. Install the appropriate wiring harness for your vehicle. (Section 1 or 2)
- b. With the lid open, LEDs should be lit. Close the lid approximately $\frac{3}{4}$ of the way and confirm LED lights turn off.

Replacement Parts:

(Also see the Saddle Box installation manual for additional replacement/service parts)

Part Number	Description
74839-0	Magnet bracket assembly for clear color saddle box
74839-52	Magnet bracket assembly for textured matte black saddle box

