

Operator's Manual

Pump

PS2 500 PS2A 500 PS2 750



Type	PS2 500, PS2A 500, PS2 750
Document	5000187791
Date	1115
Version	04
Language	EN



Copyright notice

© Copyright 2015 by Wacker Neuson Production Americas LLC

All rights, including copying and distribution rights, are reserved.

This publication may be photocopied by the original purchaser of the machine. Any other type of reproduction is prohibited without express written permission from Wacker Neuson Production Americas LLC.

Any type of reproduction or distribution not authorized by Wacker Neuson Production Americas LLC represents an infringement of valid copyrights. Violators will be prosecuted.

Trademarks

All trademarks referenced in this manual are the property of their respective owners.

Manufacturer

Wacker Neuson Production Americas LLC

N92W15000 Anthony Avenue

Menomonee Falls, WI 53051 U.S.A.

Tel: (262) 255-0500 · Fax: (262) 255-0550 · Tel: (800) 770-0957

www.wackerneuson.com

Original instructions

This Operator's Manual presents the original instructions. The original language of this Operator's Manual is American English.

Foreword

SAVE THESE INSTRUCTIONS—This manual contains important instructions for the machine models below. These instructions have been written expressly by Wacker Neuson Production Americas LLC and must be followed during installation, operation, and maintenance of the machines.

Machines covered in this manual

Machine	Item Number
PS2 500	0009113 0009172
PSA2 500	0009114
PS2 750	0009115 0009116

Machine documentation

- From this point forward in this documentation, Wacker Neuson Production Americas LLC will be referred to as Wacker Neuson.
- Keep a copy of the Operator's Manual with the machine at all times.
- Use the separate Parts Book supplied with the machine to order replacement parts.
- Refer to the separate Repair Manual for detailed instructions on servicing and repairing the machine.
- If you are missing any of these documents, please contact Wacker Neuson to order a replacement or visit www.wackerneuson.com.
- When ordering parts or requesting service information, be prepared to provide the machine model number, item number, revision number, and serial number.

Expectations for information in this manual

- This manual provides information and procedures to safely operate and maintain the above Wacker Neuson model(s). For your own safety and to reduce the risk of injury, carefully read, understand, and observe all instructions described in this manual.
- Wacker Neuson expressly reserves the right to make technical modifications, even without notice, which improve the performance or safety standards of its machines.
- The information contained in this manual is based on machines manufactured up until the time of publication. Wacker Neuson reserves the right to change any portion of this information without notice.

Manufacturer's approval

This manual contains references to *approved* parts, attachments, and modifications. The following definitions apply:

- **Approved parts or attachments** are those either manufactured or provided by Wacker Neuson.
- **Approved modifications** are those performed by an authorized Wacker Neuson service center according to written instructions published by Wacker Neuson.

- **Unapproved parts, attachments, and modifications** are those that do not meet the approved criteria.

Unapproved parts, attachments, or modifications may have the following consequences:

- Serious injury hazards to the operator and persons in the work area
- Permanent damage to the machine which will not be covered under warranty

Contact your Wacker Neuson dealer immediately if you have questions about approved or unapproved parts, attachments, or modifications.

Foreword	3
1 Safety Information	7
1.1 Signal Words Used in this Manual	7
1.2 Machine Description and Intended Use	8
1.3 Operating and Electrical Safety	9
1.4 Service Safety	10
1.5 Labels	11
2 Lifting and Transporting	12
3 Installation	13
3.1 Components	13
3.2 Preparing the Machine for First Use	14
3.3 Application Area	14
3.4 Preparing for Installation	15
3.5 Checks to Make Before Installation	17
3.6 Electrical Wiring	18
3.7 Connecting the Power Supply	19
3.8 Cable Assembly	20
4 Operation	21
4.1 Before Starting	21
4.2 Operating Water Level	23
4.3 Motor Protection System (Motor Protector)	24
4.4 Operating Cycle of Automatic Type	24
4.5 Emergency Shutdown Procedure	25
5 Maintenance	26
5.1 Periodic Maintenance Schedule	26
5.2 Storage	27
5.3 Replacement Parts	28
5.4 Disassembly and Reassembly	29
5.5 Disassembly	30
5.6 Reassembly	31
5.7 Troubleshooting	32

6	Technical Data	33
6.1	Standard Specifications	33
6.2	Operating Specifications	34
6.3	Dimensions	34
7	Schematics	35
8	AEM Safety Manual	39

1 Safety Information

1.1 Signal Words Used in this Manual

This manual contains **DANGER**, **WARNING**, **CAUTION**, **NOTICE**, and **NOTE** signal words which must be followed to reduce the possibility of personal injury, damage to the equipment, or improper service.



This is the safety alert symbol. It is used to alert you to potential personal hazards.

- ▶ Obey all safety messages that follow this symbol.



DANGER

DANGER indicates a hazardous situation which, if not avoided, will result in death or serious injury.

- ▶ To avoid death or serious injury from this type of hazard, obey all safety messages that follow this signal word.
-



WARNING

WARNING indicates a hazardous situation which, if not avoided, could result in death or serious injury.

- ▶ To avoid possible death or serious injury from this type of hazard, obey all safety messages that follow this signal word.
-



CAUTION

CAUTION indicates a hazardous situation which, if not avoided, could result in minor or moderate injury.

- ▶ To avoid possible minor or moderate injury from this type of hazard, obey all safety messages that follow this signal word.
-

NOTICE: Used without the safety alert symbol, **NOTICE** indicates a situation which, if not avoided, could result in property damage.

Note: A Note contains additional information important to a procedure.

1.2 Machine Description and Intended Use

This machine is a submersible water pump. The Wacker Neuson Submersible Pump consists of an electric motor, an impeller, a strainer, and a metal casing with ports for water suction and discharge. Power is supplied to the pump through a corded plug or a hard-wired connection, depending on the installation. The operator connects hoses to the pump and routes them so that water is pumped from the work area and discharged into an appropriate location.

This machine is intended to be used for general de-watering applications. This machine is intended for the pumping of clear water, or water containing solids up to the size stated within the products specifications, and up to the flow, head, and suction lift limits also stated within the product specifications.

This machine has been designed and built strictly for the intended use described above. Using the machine for any other purpose could permanently damage the machine or seriously injure the operator or other persons in the area. Machine damage caused by misuse is not covered under warranty.

The following are some examples of misuse:

- Pumping flammable, explosive, or corrosive fluids
- Pumping hot or volatile fluids that result in pump cavitation
- Operating the pump outside of product specifications due to incorrect diameter hoses, incorrect length hoses, other inlet or outlet restrictions, or excessive suction lift or head
- Using the machine as a ladder, support, or work surface
- Using the machine to carry or transport passengers or equipment
- Operating the machine outside of factory specifications
- Operating the machine in a manner inconsistent with all warnings found on the machine and in the Operator's Manual.

This machine has been designed and built in accordance with the latest global safety standards. It has been carefully engineered to eliminate hazards as far as practicable and to increase operator safety through protective guards and labeling. However, some risks may remain even after protective measures have been taken. They are called residual risks. On this machine, they may include exposure to:

- Electric shock from improper electrical connections or high voltage
- Personal injury from improper lifting techniques
- Projectile hazard from discharge

To protect yourself and others, make sure you thoroughly read and understand the safety information presented in this manual before operating the machine.

Operator qualifications

Only trained personnel are permitted to start, operate, and shut down the machine. They also must meet the following qualifications:

- have received instruction on how to properly use the machine
- are familiar with required safety devices

The machine must not be accessed or operated by:

- children
- people impaired by alcohol or drugs

Personal Protective Equipment (PPE)

Wear the following Personal Protective Equipment (PPE) while operating this machine:

- Close-fitting work clothes that do not hinder movement
- Safety glasses with side shields
- Hearing protection
- Safety-toed footwear

Replacement parts

When replacement parts are required for this machine, use only Wacker Neuson replacement parts or those parts equivalent to the original in all types of specifications, such as physical dimensions, type, strength, and material.

1.3 Operating and Electrical Safety



To reduce risk of electric shock, connect only to a properly grounded, grounding-type receptacle.

Risk of electric shock—this pump has not been investigated for use in swimming pool areas.

An acceptable motor-control switch shall be provided at the time of installation according to local codes and regulations.

To reduce risk of electric shock, follow instructions in this manual for proper installation.

CAUTION: This pump may automatically restart. Prior to working on the pump or control panel, all supply circuits must be disconnected.

CAUTION: Risk of shock—do not remove cord and strain relief.

1.4 Service Safety

Service training

Before servicing or maintaining the machine:

- Read and understand the instructions contained in all manuals delivered with the machine.
- Familiarize yourself with the location and proper use of all controls and safety devices.
- Only trained personnel shall troubleshoot or repair problems occurring with the machine.
- Contact Wacker Neuson for additional training if necessary.

When servicing or maintaining this machine:

- Do not allow improperly trained people to service or maintain the machine. Personnel servicing or maintaining the machine must be familiar with the associated potential risks and hazards.

Personal Protective Equipment (PPE)

Wear the following Personal Protective Equipment (PPE) while servicing or maintaining this machine:

- Close-fitting work clothes that do not hinder movement
- Safety glasses with side shields
- Hearing protection
- Safety-toed footwear



In addition, before servicing or maintaining the machine:

- Tie back long hair.
- Remove all jewelry (including rings).

Replacing parts and labels

- Replace worn or damaged components.
- Replace all missing and hard-to-read labels.
- When replacing electrical components, use components that are identical in rating and performance as the original components.
- When replacement parts are required for this machine, use only Wacker Neuson replacement parts or those parts equivalent to the original in all types of specifications, such as physical dimensions, type, strength, and material.

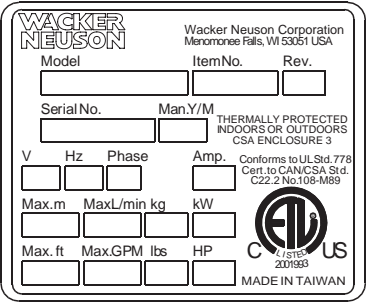
1.5 Labels

	<p>A nameplate listing the model number, item number, revision number, and serial number is attached to each unit. Please record the information found on this nameplate so it will be available should the nameplate become lost or damaged. When ordering parts or requesting service information, you will always be asked to specify the model number, item number, revision number, and serial number of the unit.</p>
	<p>CAUTION Do not attempt to operate this product before reading the Operator's Manual and understanding its contents. Mishandling of this product may result in explosion, fire, or electrical shock.</p> <ul style="list-style-type: none"> ■ Do not pull on the power cord or use the power cord to lift the pump. ■ Always use a dedicated ground leakage circuit breaker. ■ Be sure to install the ground wire securely. ■ Be sure to disconnect the power supply before handling or inspecting the pump. <p>Never insert your hand into the pump inlet holes while the pump is connected to the power supply.</p>

2 Lifting and Transporting



Do not under any circumstances install or move the pump by suspending it from the cable assembly. The cable may be damaged, causing electrical leakage, shock, or fire.

When installing the pump, pay close attention to its center of gravity and weight. If it is not lowered into place correctly, it may fall and be damaged or cause injury.



When transporting the pump by hand, be sure to employ manpower commensurate with the weight of the pump. To avoid back injury when lifting the pump, bend the knees to pick it up rather than bending your back only.

Avoid dropping the pump or other strong impact. Lift the pump by holding it firmly with the hands or by attaching a rope or chain to the handle.



Model PSA2 500—Do not lift or hang the pump by the level relay unit (1). It will lead to damage and may cause leakage, electric shock, and fire

See Graphic: *wc_gr000259*

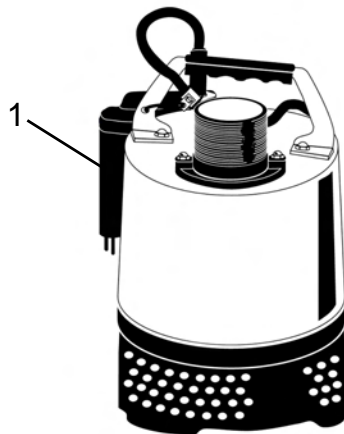

wc_gr000259

3 Installation

3.1 Components

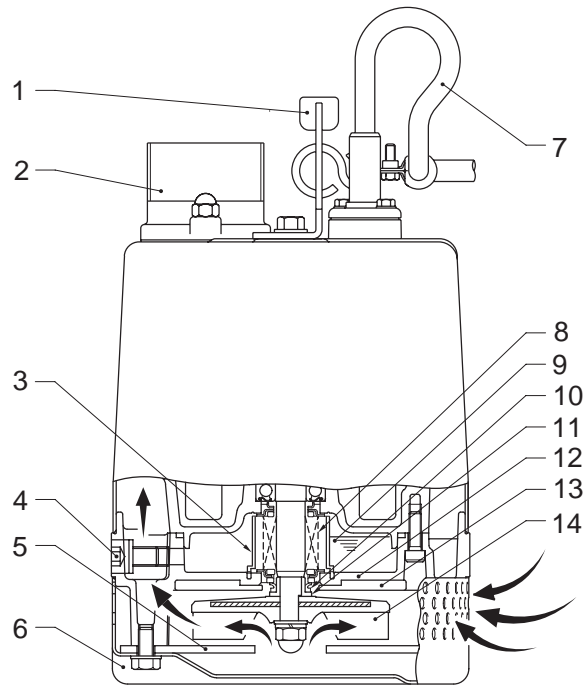

wc_gr001185

Ref.	Description	Ref.	Description
1	Lifting handle	8	Seal-mechanical
2	Coupling	9	Lubricant
3	Oil lifter	10	Seal-dust
4	Oil plug	11	Sleeve
5	Cover-suction	12	Housing-oil
6	Strainer	13	Wear ring
7	Cable assembly	14	Impeller

3.2 Preparing the Machine for First Use

When the pump is delivered, first perform the following checks:

- Inspection

While unpacking, inspect the product for damage during shipment, and make sure all bolts and nuts are tightened properly.

- Specification check

Check the model number to make sure it is the product that was ordered. Be certain it is the correct voltage and frequency.

Note: *If there is any problem with the product as shipped, contact your nearest dealer or Wacker Neuson representative at once.*

- Product specifications



Do not operate this product under any conditions other than those for which it is specified. Failure to observe this precaution can lead to electrical shock, current leakage, fire, water leakage or other problems.

3.3 Application Area



If the pump is used to drain a swimming pool, the pump must be connected to a Ground Fault Interrupter (GFI).

If the pump is used in fountains, the pump must be connected to a Ground Fault Interrupter (GFI).

The pump must not be used when people are in the water.

Leakage of pump lubricants may cause pollution of water.

Proper plug must be provided according to local codes and standards. Refer to wiring diagram.

Do not use this pump in liquids other than water, such as oil, salt water, or organic solvents.

Use with a power supply voltage within $\pm 5\%$ of the rated voltage.

Do not use in water temperatures outside the range of 0–40°C (32–104°F) which can lead to failure, current leakage or shock.

Do not use in the vicinity of explosive or flammable materials.

Use only in fully assembled state.

Note: *Consult your local dealer or Wacker Neuson representative before using with any liquids other than those indicated in this document.*

- 3.3.1 Install the pump in a location with sufficient water level, where water collects readily.

Note: See “Operating Water Level” for the water level necessary for operation. The discharge end of the hose should be located higher than the water surface. If the end of the hose is submerged, water may flow back to the pump when the pump is stopped; and if the hose end is lower than the water surface, water may overflow when the pump is turned off.

- 3.3.2 The hose should be run as straight as possible, since excessive bending will hinder the water flow, preventing sufficient lift, and can even cause the hose to become clogged with earth. If the hose is crimped near the pump, air can become trapped in the pump and cause idle running.



CAUTION

If large quantities of earth are sucked up, damage resulting from friction in the pump can lead to electrical leakage and shock.

- 3.3.3 Use the pump in the upright position. To prevent the pump from becoming submerged in mud, mount it on a block or other firm base if necessary.
- 3.3.4 If used in a permanent installation, where the pump is not readily accessible after installation, please contact Wacker Neuson for a duplicate nameplate to be installed at the wellhead or on the control box so that it will be readily visible.

3.4 Preparing for Installation

Before installing the pump at a work site, you will need to have the following tools and instruments ready:

- Insulation resistance tester (megohmmeter)
- AC voltmeter
- AC ammeter (clamp-on type)
- Bolt and nut tighteners
- Power supply connection tools (screwdriver or box wrench)

Note: Please also read the instructions that come with each of the test instruments.



WARNING

When installing the pump, pay close attention to its center of gravity and weight. If it is not lowered into place correctly, it may fall and be damaged or cause injury.

Note: On cable assembly handling, see *Electrical Wiring*.



CAUTION

Avoid dry operation, which will not only lower performance but can cause the pump to malfunction, leading to electrical leakage and shock.



Model PSA2 500—Do not lift or hang the pump by the level relay unit **(1)**. It will lead to damage and may cause leakage, electric shock, and fire

See Graphic: *wc_gr000259*

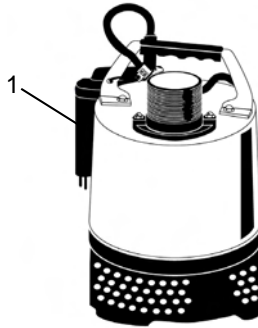

wc_gr000259

3.5 Checks to Make Before Installation

- When a grounded plug is used:
Use the megohmmeter to measure the insulation resistance between the cable assembly prongs and ground.
- When connection leads are used:
With the megohmmeter, measure the insulation resistance between each core lead and the ground lead.
Reference insulation resistance: 20MΩ or greater

Note: *The reference insulation resistance (20MΩ or greater) is the value when the pump is new or has been repaired. For the reference value after installation, see “Periodic Maintenance Table.”*



DO NOT measure the insulation resistance with insulation resistance tester for the following parts. It will cause damage (Model PSA 2 500).

Improper ways to measure insulation resistance

1	Between the plug prongs.
2	Between the electrodes on the level relay unit.
3	Between the electrodes on the level relay unit and the plug prongs.

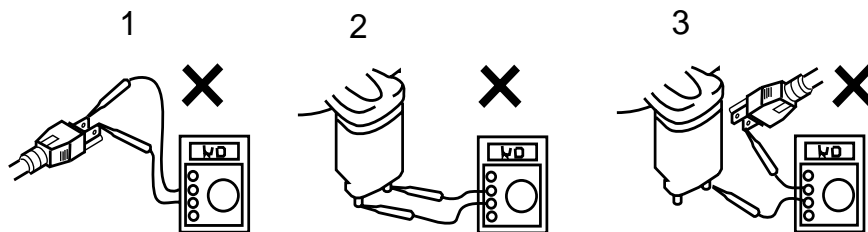

wc_gr000258

3.6 Electrical Wiring

Performing electrical wiring



Electrical wiring should be performed by a qualified person in accord with all applicable regulations. Failure to observe this precaution not only risks breaking the law but is extremely dangerous.

Incorrect wiring can lead to current leakage, electrical shock or fire.

Always make sure the pump is equipped with the specified overload protectors and fuses or breakers, so as to prevent electrical shock from a current leak or pump malfunction.

Operate within the capacity of the power supply and wiring.

Grounding



Do not use the pump without first grounding it properly. Failure to ground it can lead to electrical shock from a current leak or pump malfunction.



Do not attach the grounding wire to a gas pipe, water pipe, lightning arrester or telephone grounding wire. Improper grounding can result in electrical shock.

3.7 Connecting the Power Supply



Before connecting leads to the terminal strip, make certain the power supply is turned off (circuit breaker, etc.), to avoid electrical shock, shorting, or unexpected starting of the pump, leading to injury.

Before inserting the power supply plug, make certain the power supply is turned off (circuit breaker, etc.), to avoid electrical shock, shorting, or unexpected starting of the pump, leading to injury.



Do not use the pump with the cable assembly or plug connected loosely, which can result in electric shock, shorting, or fire.

Draw power from a dedicated power outlet rated at 15 A or above. Sharing the outlet with other equipment may cause overheating at the branch outlet and could result in fire.

NOTICE: Be sure to use a dedicated power supply with a ground leakage circuit breaker.

Grounded plug

Connect only to receptacle of proper voltage and current rating matching that of the plug provided with the cable assembly.

Without Plug

Tighten the ends of the cable assembly securely against the terminal board. If installation of a grounded plug is required, use only a properly rated and approved CEE plug and secure the ends of the cable assembly securely to power and ground terminals in accordance with the plug manufacturer's instructions.

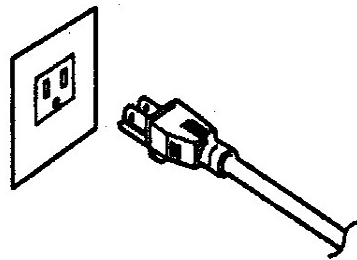

wc_gr000242

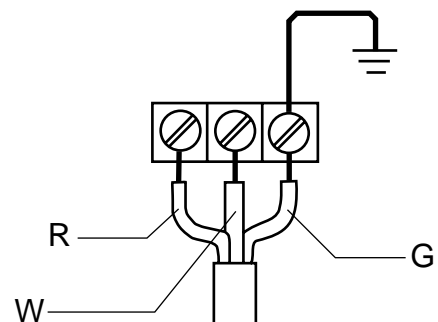

wc_gr000260

3.8 Cable Assembly



CAUTION

If it is necessary to extend the cable assembly, use a core size equal to or larger than the original. This is necessary not only to avoid a performance drop, but to prevent cable overheating which can result in fire, electrical leakage or electrical shock.

If a cable with cut insulation or other damage is submerged in the water, there is a danger of damage to the pump, electrical leakage, electrical shock, or fire.

Be careful not to let the cable assembly be cut or become twisted. This may result in damage to the pump, electrical leakage, electrical shock, or fire.

If it is necessary to submerge the connection wires of the cable assembly in water, first seal the wires completely in a molded protective sleeve, to prevent electrical leakage, electrical shock, or fire.

Do not allow the cable assembly wires or power supply plug to become wet.

Make sure the cable does not become excessively bent or twisted, and does not rub against a structure in a way that might damage it.

If used in a deep-well installation, the cable assembly should be secured every 6 m (20 ft.).

4 Operation

4.1 Before Starting

- 4.1.1 Make sure once again that the product is of the correct voltage and frequency rating.

NOTICE: Using the product at other than rated voltage and frequency will not only lower its performance but may damage the product.

Note: *Confirm the rated voltage and frequency on the model nameplate.*

- 4.1.2 Confirm the wiring, supply voltage, circuit breaker capacity, and motor insulation resistance.

Reference insulation resistance = 20 MΩ or greater.

Note: *The reference insulation resistance (20 MΩ or greater) is the value when the pump is new or has been repaired. For the reference value after installation see “Periodic Maintenance Table.”*

- 4.1.3 The setting on the circuit breaker or other overload protector should be made in accord with the rated current of the pump.

Note: *See “Operating Specifications” for the rated current of the pump.*

- 4.1.4 When powering the pump with a generator, be certain the generator is sized to supply the required power for the pump and any other equipment powered by the generator.

Non-Automatic Models (PS2 500, PS2 750)

Test Operation



WARNING

Do not operate the pump while it is suspended in the air. The recoil may result in injury or other major accident.



WARNING

Do not start the pump when people are standing next to it. A current leak can result in electrical shock.

Run the pump for a short time (3–10 minutes) and confirm the following:

- Using an ammeter (clamp-on type), measure the operating current at the L1 and L2 phase wires on the terminal.

COUNTERMEASURE: If the operating current exceeds the rated value, pump motor overload may be a cause. Make sure the pump has been installed under proper conditions as described in *Installation*.

- Using an AC voltmeter (tester), measure voltage at the terminals. Supply voltage tolerance: within ±5% of rated voltage.

COUNTERMEASURE: If the supply voltage is outside the tolerance, possible causes are the power supply capacity or an inadequate extension cable. Look again at the wiring diagram and make sure the conditions are proper.



In case of very excessive vibration, unusual noise or odor, turn off the power immediately and consult your nearest dealer or Wacker Neuson representative. Continuing to operate the pump under abnormal conditions may result in electrical shock, fire, or current leakage.

Operation



Make sure no extraneous objects such as pins, nails or other metal objects are sucked into the pump. These can damage the pump or cause it to malfunction, and can result in electrical shock or electrical leakage.

When the pump is not used for an extended period, be sure to turn off the power (circuit breaker, etc.). Deterioration of the insulation may lead to electrical leakage, electrical shock, or fire.

In case of a power outage, turn off the power to the pump to avoid having it start unexpectedly when the power is restored, presenting serious danger to people in the vicinity.



The pump may become hot during operation. Do not touch an operating pump. Allow the pump to cool before handling.

Pay careful attention to the water level while the pump is operating. Dry operation may cause the pump to malfunction.

Note: See section “Operating Water Level” for the water level necessary for operation.

If the protection system operates due to an overload or malfunction, causing the pump to stop, first investigate and remove the cause before restarting.

4.2 Operating Water Level



Do not operate the pump below the C.W.L. (Continuous running Water Level) indicated below. Failure to observe this condition may result in damage to the pump, current leakage or electrical shock.

See Graphic: wc_gr001225

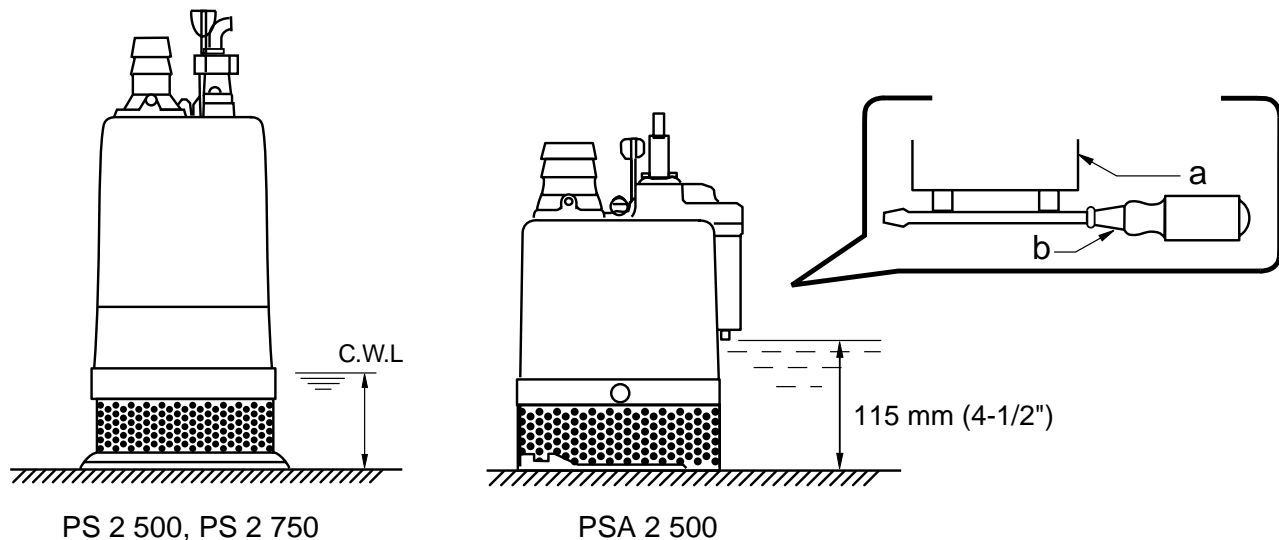

wc_gr001225

Operating Water Level (PS 2 500, PS 2 750).

Pump Model	C.W.L.
PS 2 500	50mm (2")
PS 2 750	100mm (4")

Operating water level (PSA2 500 only)

Starting the Pump:

This pump starts when water reaches the electrodes on the level relay unit, conducting current between them.

Note: The necessary water level to operate the pump is 115 mm (4-1/2") from the bottom of the pump. To force start the pump for trial operation, short-circuit the electrodes (a) with a screwdriver (b) as illustrated. Please keep items that may clog the pump (such as wires, nails, cords, etc.) away from it.

4.3 Motor Protection System (Motor Protector)

Circle Thermal protector (PS 2 750)

Miniature Protector (PS 2 500, PSA 2 500)

The pump has a built-in motor protection system. If an excessive current is detected (PS 2 750) or the motor overheats, for reasons such as the following, the pump will automatically stop operating regardless of the water level, to protect the motor:

- Change in supply voltage polarity
- Overload
- Open-phase operation or operation under constraint

Note: Always determine the cause of the problem and resolve it before resuming operation. Simply repeating cycles of stopping and restarting will end up damaging the pump. Do not continue operation at very low lift, low water level, or while the strainer stand is clogged with debris. Not only will performance suffer, but also such conditions may cause noise, heavy vibration, and malfunctioning.

4.4 Operating Cycle of Automatic Type

Stage	Level Relay Unit	Pump	Water Level
1	When electrodes (b) of level relay units (a) submerge under water, the resulting electric current causes the pump to operate. (Electrodes sensing the electricity)	Operation starts (drainage)	Falls
2	When the water level goes below the height of the electrodes, a timer is activated. The pump keeps operating. (No electric current →Timer activates.)	Operation remains (drainage)	Falls
3	The pump keeps operating for approximately one minute. (The pump resumes the operation if the electrodes contact the water again within one minute.)	Operation remains (drainage)	Falls
4	The pump stops one minute later. (The pump may not stop operating for a longer period of time.)	Operation stops	Rises
5	When the water level rises again and the electrodes touch the water, the pump starts operating again. (Electrodes sensing the electricity)	Operation starts again (drainage)	Falls

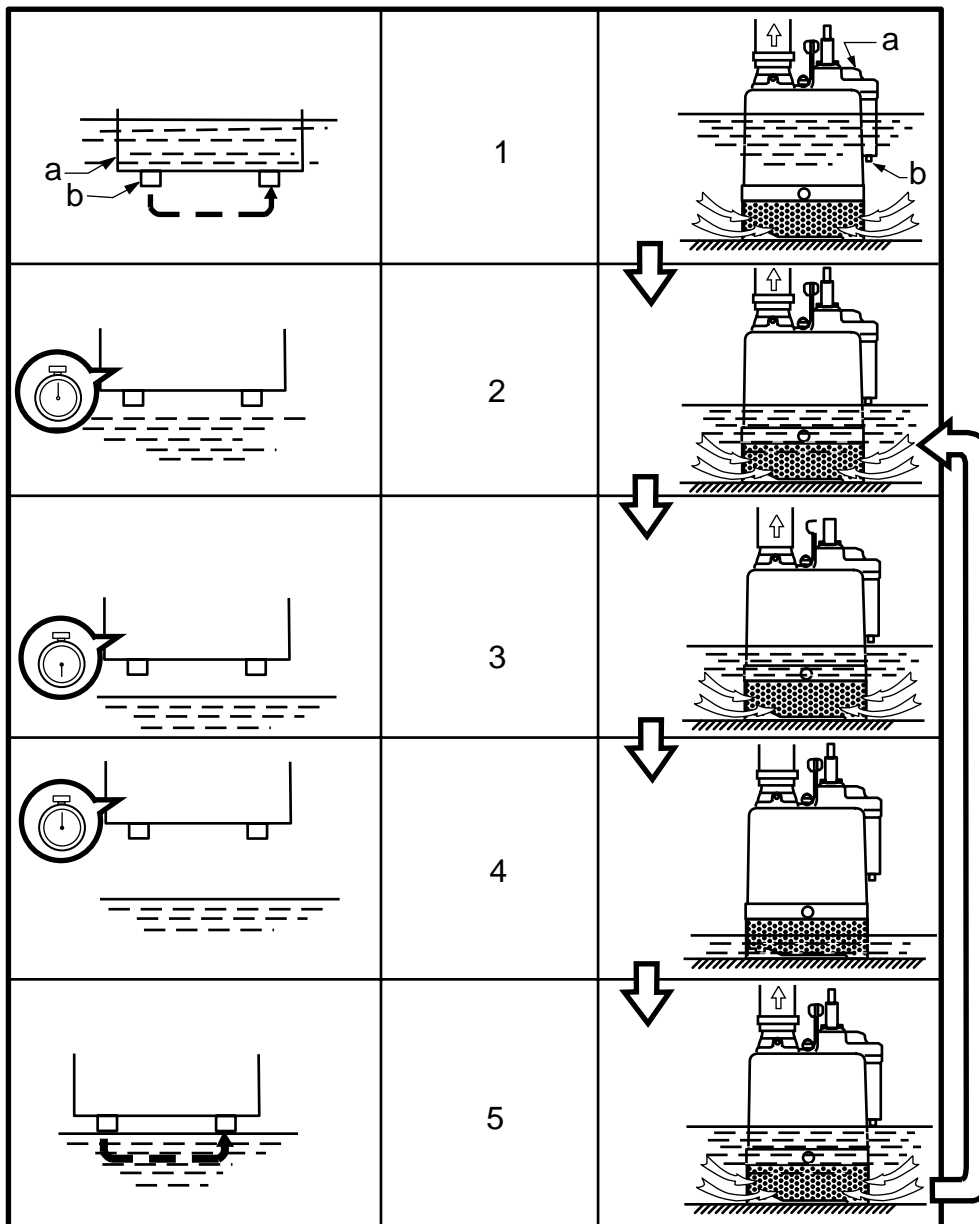

wc_gr000312

4.5 Emergency Shutdown Procedure

If a breakdown/accident occurs while the machine is operating, follow the procedure below.

- 4.5.1 Turn off the pump.
- 4.5.2 Disconnect the power supply.
- 4.5.3 Contact the rental yard or machine owner.

5 Maintenance

5.1 Periodic Maintenance Schedule

The table below lists basic machine maintenance. Tasks designated with check marks may be performed by the operator. Tasks designated with square bullet points require special training and equipment.

Pump	Weekly	Monthly	Every 1000 hrs.	Every 2000 hrs.
Measure insulation resistance. Reference insulation resistance = 1MΩ or greater. (1)	■			
Measure operating current. Compare with rated current.	■			
Measure supply voltage. Compare with allowable range (within ±5% of rated voltage).	■			
Pump inspection. A noticeable drop in performance may indicate wear in the impeller, etc., or else clogging of the strainer, etc. Remove the clogged debris and replace any worn parts.		■		
Lubricant inspection.			■	
Change lubricant.				■
Designated lubricant: SAE 10W/20W. (2)				■
Change mechanical seal. (3)				■
Overhaul. This should be carried out even if there are no problems with the pump. The frequency depends on how continuously the pump is in use. (4)				■

(1) If the insulation resistance has become noticeably lower than the previous inspection, an inspection of the motor will be necessary.

(2) See *Inspecting Lubricant and Replacing Lubricant* in this section.

(3) Specialized know-how is required for inspecting and replacing the mechanical seal. Consult with your nearest dealer or Wacker Neuson representative.

(4) Consult with your nearest dealer or Wacker Neuson representative regarding overhauls.

Maintenance and Inspection

Regular maintenance and inspections are a necessity for continued efficient functioning of the pump. If any abnormal conditions are noticed, refer to the *Troubleshooting* section and take corrective measures immediately. It is recommended that a spare pump be kept ready in case of any problems.

Prior to inspecting



Before inspecting the pump, make certain the power supply (circuit breaker, etc.) is turned off. Then, unplug the cable assembly from the receptacle or detach it from the terminals. Failure to follow this precaution may result in a serious accident from electrical shock or unexpected starting of the pump motor.

5.1.1 Washing the pump

Remove accumulated matter from the surface of the pump and wash it with clean water. Take special care to remove any debris from the impeller.

5.1.2 Inspecting the pump exterior

Look for any peeling or chipped paint, and make sure the nuts and bolts are fastened tightly. Any cracks in the surface should be repaired by cleaning that area, drying it and then applying a touch-up coating.

Note: *Touch-up paint is not supplied. Note that some kinds of damage or looseness may require that the unit be disassembled for repairs. Please consult your nearest dealer or Wacker Neuson representative.*

5.2 Storage

When the pump is out of use for an extended period, wash it and dry it thoroughly, then store it indoors.

Note: *Always run a test operation before putting the pump back into service.*

If the pump is left in the water, it should be run a minimum of once a week.

- **Inspecting Lubricant**

Remove the oil plug and tilt the pump to drain a small amount of lubricant. If the lubricant is milky white or has water mixed in with it, the mechanical seal may be faulty. In this case the pump will need to be disassembled and repaired.

- **Replacing Lubricant**

Remove the oil plug and drain all the lubricant, then replace it with the specified amount.

Note: *Worn lubricant and other waste products should be disposed of by a qualified agent, in accord with applicable laws. The oil plug gasket should be replaced each time the lubricant is inspected or changed.*

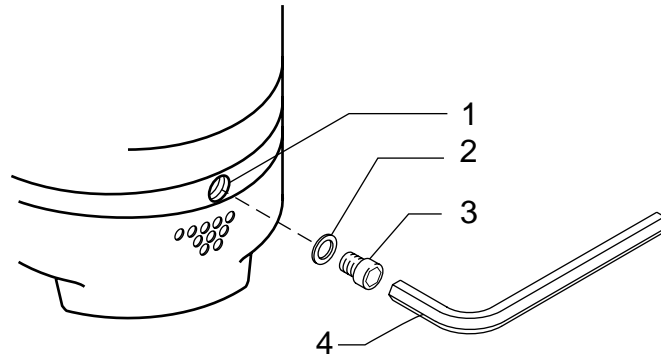

wc_gr001204

Ref.	Description	Ref.	Description
1.	Oil Inlet	3.	Oil Plug
2.	Gasket	4.	Allen Wrench

Pump Model	Lubricant Capacity
PS 2 400	160 ml (5.4 fl. oz.)
PS 2 500, PSA 2 500	155 ml (5.2 fl. oz.)
PS 2 750	210 ml (7.1 fl. oz.)

5.3 Replacement Parts

The table lists the parts that need to be replaced periodically. Replace these using the recommended frequency as a guideline.

Part	Replacement Frequency
Mechanical seal	When lubricant in oil compartment becomes milky.
Lubricant (SAE 10W/20W)	Every 2,000 hours or 12 months, whichever comes first.
Gasket	Each time pump is disassembled or inspected.
Dust seal	When ring is worn, and each time pump is disassembled or inspected.
Sleeve	When it becomes worn.

5.4 Disassembly and Reassembly



Before disassembling the pump, make certain the power supply (circuit breaker, etc.) is turned off. Then, unplug the cable assembly from the receptacle or detach it from the terminals. To avoid electrical shock, do not work with wet hands.

Do not check the operation of any parts (impeller rotation, etc.) by turning on the power while the unit is partially assembled. Failure to observe these precautions may result in a serious accident.

Do not disassemble or repair any parts other than those designated here. If repairs are necessary in any other than the designated parts, consult your nearest dealer or Wacker Neuson representative. Improper repairs can result in electrical leakage, electrical shock, fire, or water leaks.

After reassembly, always perform a test operation before resuming use of the pump. Improper assembly will cause the pump to malfunction, resulting in electric shock or water leaks.

The procedure for disassembly and reassembly is shown here to the extent necessary for impeller replacement. A specialized environment and facilities are necessary for work on the mechanical seal and the motor parts. Contact your nearest dealer or Wacker Neuson representative in the event such repairs are necessary.

5.5 Disassembly

See Graphic: wc_gr001206

5.5.1 Removing the strainer, suction cover, and volute:

Remove the bolts (1) under the strainer (2), then remove the strainer, suction cover (3), and volute (4).

5.5.2 Removing the Impeller:

With a box wrench or other tool, remove the acorn nut (6), lockwasher (7) and washer (8), then remove the impeller (9), sleeve (10) and dust seal (11) from the shaft.

5.5.3 Removing the wear ring:

Remove the wear ring (12) from the volute.



WARNING

A worn impeller may have sharp edges that can cause injury, and should be handled with care.

Note: The exploded view shown is for model PS 2 500. Other models may differ slightly in shape and structure.

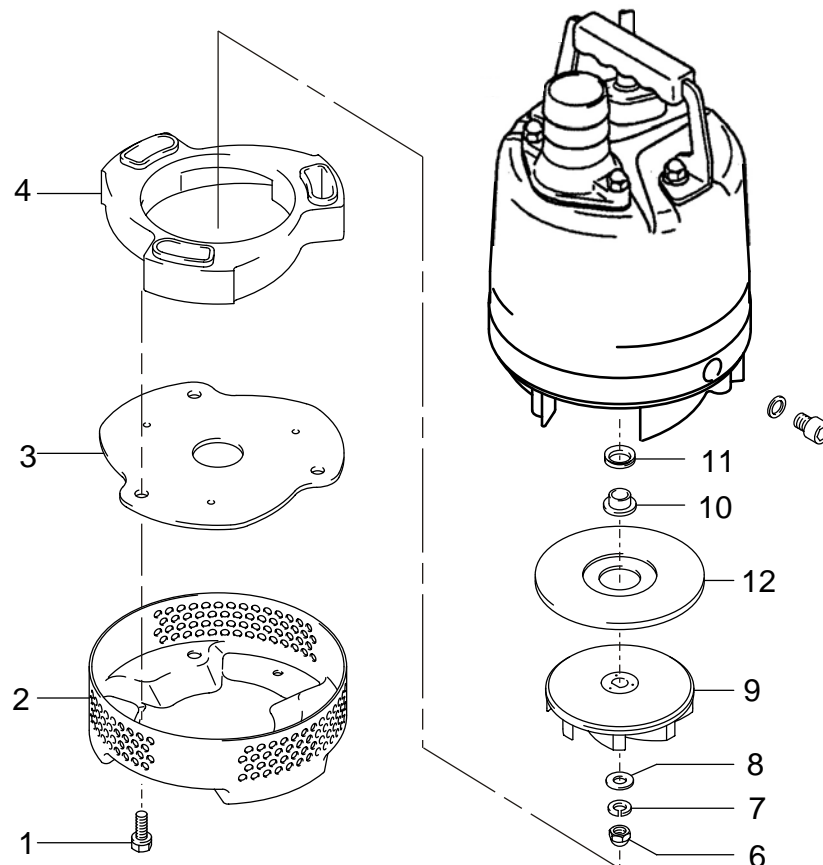

wc_gr001206

5.6 Reassembly

See Graphic: *wc_gr001206*, *wc_gr001205*

- 5.6.1 Mount the dust seal (**11**) onto the outside of the sleeve (**10**) as shown in the drawing. When doing so, do not apply oil or other lubrication to the surface where the dust seal contacts the sleeve (**a**).
- 5.6.2 When replacing the wear ring (**12**), make sure the front and back are oriented correctly. The side with the protrusions around the edge should face the volute (**4**). Press the wear ring firmly onto the surface.
- 5.6.3 Replace the dust seal and sleeve as one piece.
- 5.6.4 Align the impeller keyway with the rotor shaft keyway and push the impeller (**9**) onto the rotor shaft. Secure the impeller on the shaft with the washer (**8**), lockwasher (**7**), and acorn nut (**6**). While keeping the impeller and shaft from rotating, tighten the acorn nut.
- 5.6.5 Position volute (**4**) flush with oil housing. Assemble suction cover (**3**) and strainer (**2**) and secure the assembly with the three bolts (**1**).

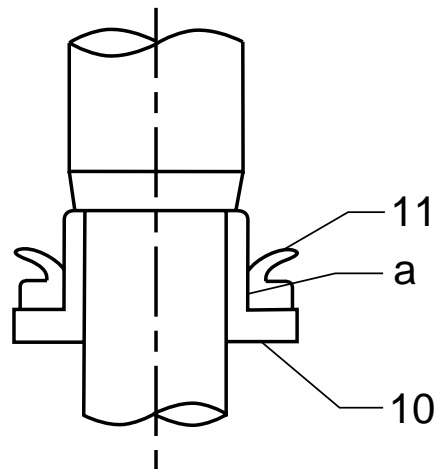

wc_gr001205

5.7 Troubleshooting

Before ordering repairs, carefully read through this manual, then repeat the inspection. If the problem remains, contact your nearest dealer or Wacker Neuson representative.



ALWAYS turn off the power before inspecting the pump. Failure to observe this precaution can result in serious accident.

Problem / Symptom	Reason / Remedy
Pump will not start	<ul style="list-style-type: none"> • Power is off. Restore power. • Cable assembly is cut or not connected properly. Repair/replace the cable or fix the connection. • Plug is not inserted. Connect the plug. • Impeller is clogged. Inspect the pump and remove any debris. • Start float does not operate. Remove any obstruction and check the float operation.
Pump stops soon after starting (Motor protector operates)	<ul style="list-style-type: none"> • Impeller is clogged. Remove debris. • Low voltage. Provide the rated voltage, or make sure the cable assembly extension is the proper standard. • Wrong power frequency. Check the nameplate, and replace the pump or the impeller. • Extended operation with a clogged strainer. Remove debris from the strainer. • Faulty motor (burning, water infiltration, etc.). Repair or replace the motor. • Motor protection system was triggered. Identify and correct cause before re-starting.
Poor lift or discharge capacity	<ul style="list-style-type: none"> • Worn out impeller or suction cover. Repair or replace the worn parts. • Sharply bent or clogged hose. Straighten out any sharp bends. Enclose the pump with a screen to keep away debris. • Strainer clogged or buried. Remove debris from the strainer, or place a block under the pump. • Wrong power frequency. Check the nameplate, and replace the pump or the impeller.
Heavy vibration or noise	<ul style="list-style-type: none"> • Damaged motor shaft. Contact dealer and replace motor.
Pump will not stop automatically	<ul style="list-style-type: none"> • Something is interfering with the float operation, or the float switch is faulty. Remove any obstacles, or replace the switch.

6 Technical Data

6.1 Standard Specifications

Applicable Liquids, Consistency and Temperature	Rain Water, Fountain Water, Ground Water, Sand-Carrying Water 0–40°C (32–104°F)	
Pump	Impeller	Semi-Vortex Type: (PS 2 500, PSA 2 500) Open Type: (PS 2 750)
	Shaft Seal	Double Mechanical Seal
	Bearing	Shielded Ball Bearing
Motor	Specification	Dry Submersible Induction Motor (2-Pole)
	Insulation	Class E
	Protection System	Miniature Protector: (PS 2 500, PSA 2 500) Circle Thermal Protector: (PS 2 750)
	Lubricant	SAE 10W/20W Such as: –Turbine Oil ISO VG #32 –Shell Victrolia Oil #27 –British Pet Energol THB #32 –Gulf Paramount #32 –Tellus #T22 Shell Oil –Shell Turbo T32
Connection	Coupling (NPT 2")	

6.2 Operating Specifications

Part No.	PS 2 500		PSA 2 500	PS 2 750		
	0009113	0009172	0009114	0009115	0009116	
Pump						
Electric Power	V/Ph/Hz	110/1/60	220/1/60	110/1/60	110/1/60	220/1/60
Rated Current	A	6.1	3.0	6.1	11.5	6.5
Starting Method		Capacitor-Run				
Bore	mm (in.)	50 (2)				
Output	kW (Hp)	0.48 (0.66)			0.75 (1)	
Maximum Head	m (ft.)	12 (39.5)			18 (60)	
Maximum Capacity	L/min (GPM)	236 (62.4)			276 (73)	
Maximum Pressure	psi	17			26	
Solid Size Capacity	mm (in.)	6 (0.2)				
Weight*	Kg (lbs.)	9.5 (21)		10 (22)	16 (35)	

* The weight (mass) given above is the operating weight of the pump itself, not including the cable assembly.

6.3 Dimensions

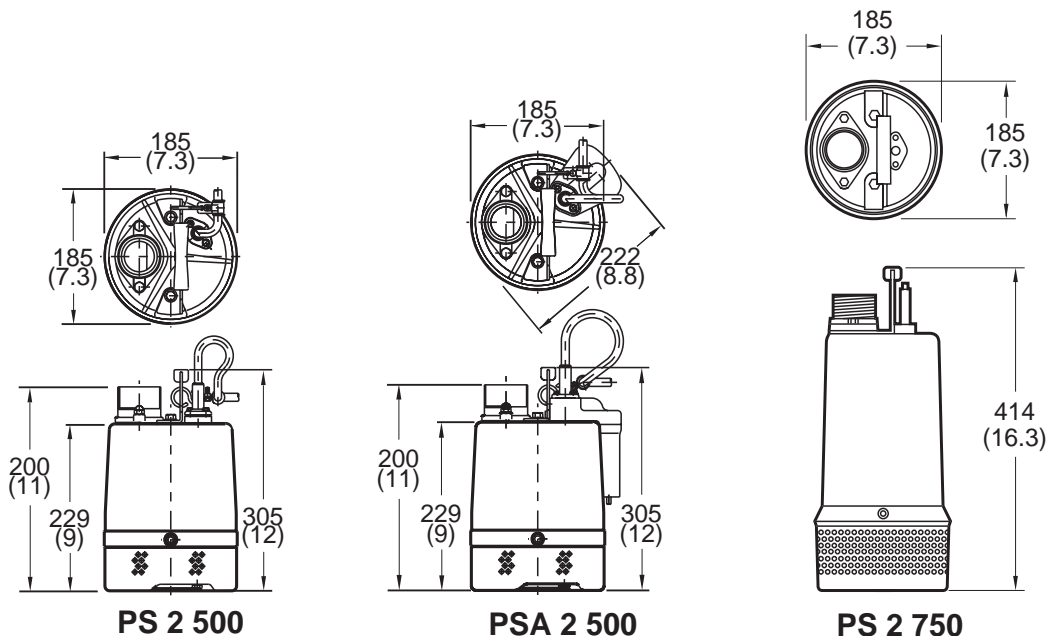

wc_gr001221

7 Schematics

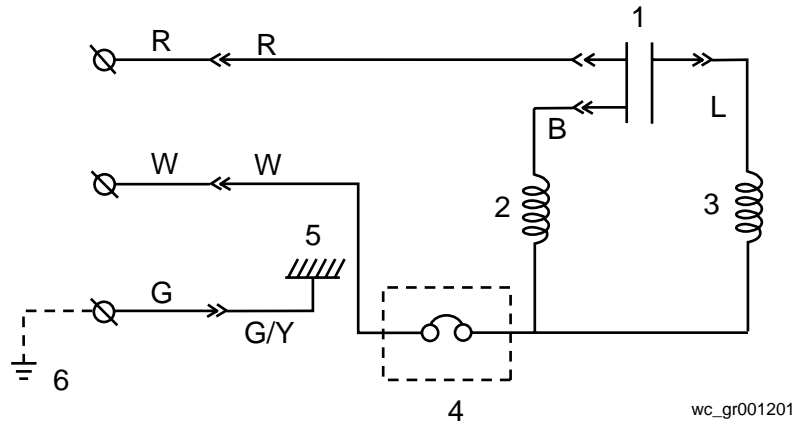

PS 2 500 POWER SOURCE SINGLE PHASE

Ref.	Description	Ref.	Description
1	Capacitor	6	Ground
2	Main coil	7	Circle thermal protector
3	Auxiliary coil	8	Float switch (normally open contact)
4	Miniature protector	9	Heater
5	Frame grounding		

Wire Colors					
B	Black	V	Violet	Or	Orange
G	Green	W	White	Pr	Purple
L	Blue	Y	Yellow	Sh	Shield
P	Pink	Br	Brown	LL	Light Blue
R	Red	Cl	Clear	G/Y	Green/Yellow
T	Tan	Gr	Gray		

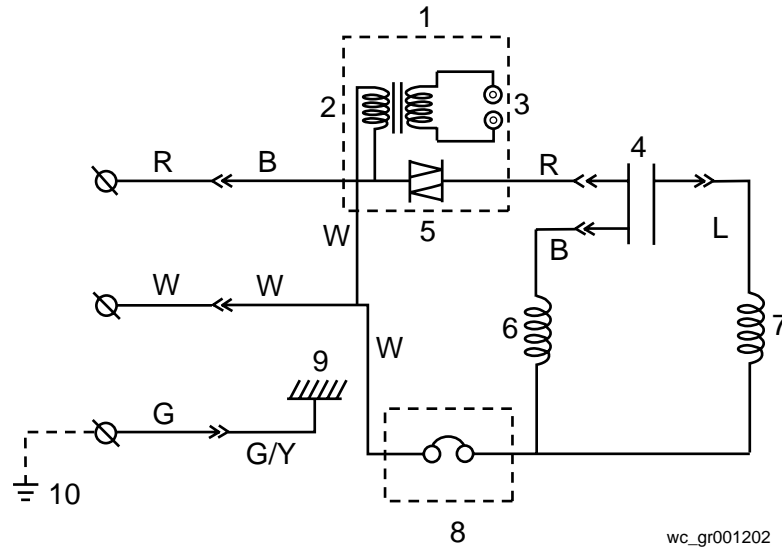

wc_gr001202

PSA2 500 POWER SOURCE SINGLE PHASE

Ref.	Description	Ref.	Description
1	Level Relay Unit	6	Main Coil
2	Transformer	7	Auxiliary Coil
3	Electrode	8	Miniature Protector
4	Capacitor	9	Frame Grounding
5	Triac	10	Ground

Wire Colors					
B	Black	V	Violet	Or	Orange
G	Green	W	White	Pr	Purple
L	Blue	Y	Yellow	Sh	Shield
P	Pink	Br	Brown	LL	Light Blue
R	Red	Cl	Clear	G/Y	Green/Yellow
T	Tan	Gr	Gray		

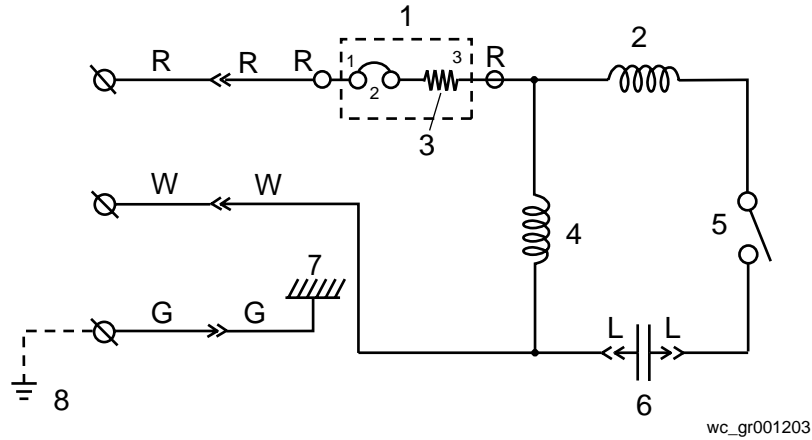

PS 2 750 POWER SOURCE SINGLE PHASE

Ref.	Description	Ref.	Description
1.	Circle Thermal Protector	5.	Centrifugal Switch
2.	Auxiliary Coil	6.	Capacitor
3.	Heater	7.	Frame Grounding
4.	Main Coil	8.	Ground

Wire Colors					
B	Black	V	Violet	Or	Orange
G	Green	W	White	Pr	Purple
L	Blue	Y	Yellow	Sh	Shield
P	Pink	Br	Brown	LL	Light Blue
R	Red	Cl	Clear	G/Y	Green/Yellow
T	Tan	Gr	Gray		



If connected to a circuit protected by a fuse, use a time-delay fuse with this pump.

Notes



PORTABLE PUMPS

www.aem.org



SAFETY MANUAL

FOR OPERATING AND MAINTENANCE PERSONNEL

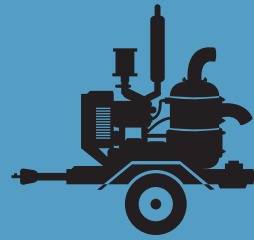
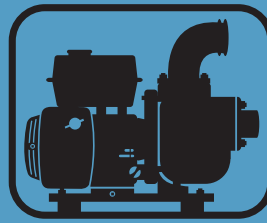

SAFETY ALERT SYMBOL



This Safety Alert Symbol means
ATTENTION is involved!

The Safety Alert Symbol identifies important safety messages on machines, safety signs, in manuals, or elsewhere. When you see this symbol, be alert to the possibility of personal injury or death. Follow the instructions in the safety message.

Why is SAFETY important to YOU?

3 BIG REASONS

- **Accidents KILL or DISABLE**
- **Accidents COST**
- **Accidents CAN BE AVOIDED**

NOTICE OF COPYRIGHT PROTECTION

AEM Safety Manuals are protected as a copyrighted work with ownership duly registered with the Copyright Office, Washington, D.C. Any reproduction, translation, decompiling or other use of an AEM Safety Manual, or portion thereof, or the

creation of derivative works based on an AEM Safety Manual, without the prior written approval of AEM is expressly prohibited. Copyright infringement can result in civil and criminal sanctions, damages and other penalties being imposed.

Copyright © 2004— Association of Equipment Manufacturers

1

REFERENCES

The following is a partial list of referenced material on safe operating practices:

U.S. Department of Labor publishes safety and health regulations and standards under the authority of the Occupational Safety and Health Act for the general construction and mining industries.

U.S. Department of Labor
Washington, DC 20210

NFPA — National Fire Protection Association
P.O. Box 9101
1 Battery March Park
Quincy, MA 02269-9101

SAE — Society of Automotive Engineers, Inc.
400 Commonwealth Drive
Warrendale, PA 15096
Publishes a list, "Operator Precautions" SAE J153
MAY 87.

AEM — Association of Equipment Manufacturers
111 East Wisconsin Avenue
Milwaukee, WI 53202

CONTENTS

	Page	Section
FOREWORD.....	4	
FOLLOW A SAFETY PROGRAM	5	1
PERFORM MAINTENANCE SAFELY	7	2
PREPARE FOR SAFE OPERATION	9	3
WORK SAFELY – Pumps In General	10	4
WORK SAFELY – Engine Driven Pumps.....	13	5
WORK SAFELY – Electric Motor Driven Pumps.....	15	6
WORK SAFELY – Submersibles	17	7
TEST YOUR KNOWLEDGE	19	8
FINAL WORD TO THE USER	20	9

FOREWORD

This safety manual is intended to point out some of the basic situations which may be encountered during the normal operation and maintenance of your equipment, and to suggest possible ways of dealing with these conditions.

Additional precautions may be necessary, depending on application, pump type, configuration and attachments used, conditions at the work-site or in the maintenance area. The manufacturer has no direct control over pump application, operation, inspection, lubrication or maintenance. Therefore, it is your responsibility to use good, safe, practices in these areas.

The information provided in this manual supplements the specific information about your pump that is contained in the manufacturer's manual(s). Other information which may affect the safe operation of your pump may be contained on safety signs, decals, markings, insurance requirements, employer's safety programs, safety codes, local, state/provincial and federal laws, rules and regulations, contracts, agreements and warranties.

It is your responsibility to read and understand this safety manual and the manufacturer's manual(s) before operating your pump. This safety manual takes you step-by-step through your working day. If you do not understand any of this information, or if errors or contradictions seem to exist, consult with your supervisor before operating your pump.

IMPORTANT: If you do not have the manufacturer's manual(s) for your particular pump, get a replacement manual from your employer, equipment dealer, or manufacturer of your pump. Keep this safety manual and the manufacturer's manual(s) with your pump.

Unauthorized modifications of pumps create hazards. Pumps must not be modified or altered unless prior approval is obtained from the manufacturer.

DO NOT PUMP VOLATILE/FLAMMABLE OR CAUSTIC/CORROSIVE LIQUIDS.

REFER TO THE OWNER'S MANUAL OR CONSULT WITH THE MANUFACTURER FOR THE PROPER PUMP MATERIALS IF YOU ARE TO PUMP HAZARDOUS CAUSTIC/CORROSIVE LIQUIDS.

FOLLOW A SAFETY PROGRAM

KNOW THE RULES

Every employer is concerned about safety. Safe operation and proper maintenance of your pump can prevent accidents. **KNOW** the rules — **LIVE** by them. (FIG. 1)

When starting work at a new site, check with the designated safety coordinator for specific safety instructions. **DON'T LEARN SAFETY THE HARD WAY.**

Know the meaning of all hand signals, signal flags, signs and markings.

Know the traffic rules used at the work site. Know who the signal man is; watch and obey his signals.

Know where the fire extinguishers and first aid kits are kept and how to use them. Know where to get proper aid and assistance when needed.

Use common sense to avoid accidents. If an accident does occur, be prepared to react to it quickly and effectively.

NEVER PANIC.

Remember that **YOU are the key to safety.** Good safety practices not only protect you but also protect the people around you. Study this manual and the manufacturer's manual(s) for your specific pump. Make them a working part of your safety program. Keep in mind that this safety manual is written for only this type of equipment. Practice all other usual and customary safe working precautions, and above all (FIG. 1).

REMEMBER — SAFETY IS UP TO YOU

**YOU CAN PREVENT
SERIOUS INJURY OR DEATH**



FIG. 1

1

5

FOLLOW A SAFETY PROGRAM

KNOW WHAT IT IS?

Consult your supervisor for specific instructions and personal safety equipment required.

For instance, you may need:

- Hard Hat
- Safety Shoes
- Eye Protection
- Respirators
- Heavy Gloves
- Reflector Vests
- Hearing Protection
- Face Protection
- Back Supports
- Other job related specific items

Do not wear loose clothing or any accessory — flopping cuffs, untied shoe-laces, dangling neckties and scarves, rings, wrist watches, or other jewelry — that can catch on protruding or moving parts or controls. Long hair should be securely bound to prevent entanglement with moving parts. (FIG. 3)



FIG. 2



FIG. 3

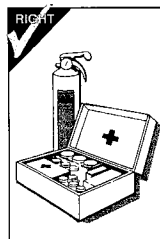

FIG. 4

BE ALERT!

Know where to get assistance. Know how to use a first aid kit and fire extinguisher or fire suppression system. (FIG. 4)

BE AWARE!

Take advantage of training programs offered.

Safety programs should require that one person at each jobsite be assigned the overall responsibility and authority for safety. Know who the person is, and **COMMUNICATE** with them.

Know what the jobsite rules are, and **FOLLOW THE RULES.** Be safety conscious, responsible and reliable. Think about safety **BEFORE** something happens.

BE CAREFUL!

Human error is caused by many factors: carelessness, fatigue, overload, preoccupation, incompatibility between operator and the equipment, drugs, and alcohol to name a few. Damage to the equipment can be fixed in a short period of time, but injury, or death has a lasting effect.

For your safety and safety of others, encourage your fellow workers to act within safety rules.

1

6

PERFORM MAINTENANCE SAFELY

CLOTHING AND PERSONAL PROTECTIVE ITEMS

ALWAYS wear appropriate safety glasses, goggles or face shield when working. (FIG. 2) Proper eye protection can keep flying particles from grinding, drilling or hammering operations, or fluids such as fuel, solvents, lubricants and brake fluids from damaging your eyes. Normal glasses do NOT provide adequate protection.

ALWAYS wear a hard hat and safety shoes. (FIG. 2) ALWAYS wear hearing protectors when exposed to high noise levels for extended periods. ALWAYS wear a respirator when painting or exposed to dusty conditions. ALWAYS keep your pockets free of loose objects which can fall out and drop into machinery. (FIG. 5) Heavy gloves should be worn for many operations.

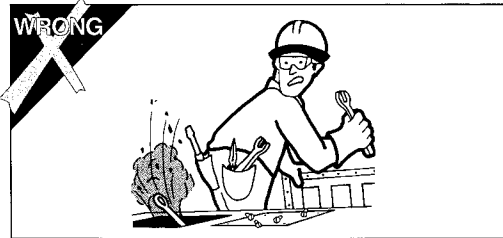

FIG. 5

EXHAUST FUMES

Engine exhaust fumes can cause sickness or death. If it is necessary to run an engine in an enclosed area, remove the exhaust fumes from the area with an exhaust pipe extension. If you do not have an exhaust pipe extension, be positive the area is adequately ventilated. (FIG. 6)



FIG. 6

HEAVY PARTS

Handle tools and heavy parts sensibly — with regard for yourself and other persons. Lower items — don't throw or drop them.

ALWAYS use proper hoisting equipment for lifting heavy loads.

ALWAYS use a back brace when lifting by hand.

2

7

PERFORM MAINTENANCE SAFELY

FIRE PREVENTION

Whenever possible use a nonflammable solvent to clean parts. Do not use gasoline or other fluids that give off harmful vapors.

If flammable fluids, such as gasoline or diesel fuel, must be used, extinguish open flames or sparks and DO NOT smoke.

Store dangerous fluids in a suitable place, in approved containers which are clearly marked. NEVER smoke in areas where flammable fluids are used or stored. (FIG. 7)

Use proper nonflammable cleaning solvents. Follow solvent manufacturer's instructions for use.

Always remove all flammable material in the vicinity of welding and/or burning operations.

ALWAYS keep the floor in the work area clean and dry. Oily, greasy floors can easily lead to falls. Wet spots, especially near electrical equipment, can be hazardous. (FIG. 7)

Know where fire extinguishers are kept — how they operate — and for what type of fire they are intended.

Check readiness of any fire detectors and fire suppression systems.



FIG. 7

2

PREPARE FOR SAFE OPERATION

LEARN TO BE SAFE

NEVER operate a pump which is new to you without first being instructed in its proper operation. READ the operator's manual. If one has not been provided, GET ONE AND STUDY IT BEFORE OPERATING THE PUMP.

Know the meaning of all identification symbols on your controls and gauges. (FIG. 8)

Know the location of the emergency shut-down control if the machine is so equipped.

Before attempting to operate the pump, know the capabilities and limitations of the pump. Familiarize yourself with controls and instruments — their locations and functions.

Keep hands, levers and knobs clean of oil or grease to prevent slipping.

Carefully read and follow the instructions on all safety signs and decals on the pump. Keep safety signs in good condition. Replace missing or damaged safety signs.

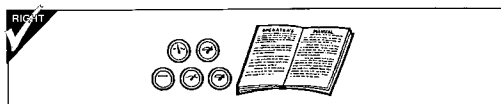

FIG. 8

CHECK IT OUT!

Know what safety devices your machine is equipped with ... and see that each item is securely in place and in operating condition. (FIG. 9)

For example:

- Drawbar Coupling Chains and Pins
- Alarms and Warning Lamps
- Reflectors
- Guards and Shields
- Drain Covers, Plugs, and Caps
- Shut-Down Devices
- Leveling Jacks
- Pressure Relief Devices
- Lifting Devices



FIG. 9

NEVER START OR OPERATE A PUMP KNOWN OR SUSPECTED TO BE DEFECTIVE OR MALFUNCTIONING.

If your daily check uncovers any items that need attention — repair, replacement, or adjustment — report them promptly. The most minor malfunction could be the result of more serious trouble — or can cause it, if pump is operated. When in doubt, attach an OSHA Lockout/Tagout device tag to the control panel to disconnected electrical power supply at breaker, on electrically driven pumps and disconnect the battery and/or spark plug wire on engine driven pumps.

3

9

WORK SAFELY — Pumps In General

SAFE WORKING PROCEDURES

USE COMMON SENSE! Most accidents can be avoided by using common sense and concentrating on the job to be done.

ONLY EXPERIENCED AND QUALIFIED personnel should install and operate pump equipment.

KNOW THE PROPER starting procedure for your equipment. Follow the manufacturer's operation manual ... to the letter.

DO NOT operate a pump without all guards and shields in place. (If OSHA required guards are damaged or misplaced, contact the manufacturer for a replacement.)

When **lifting pump** use only lifting equipment in good repair and with adequate capacity. Follow manufacturer's lifting recommendation.

Check all lubricant levels before pump installation in accordance with manufacturer's maintenance programs.

Keep hands and feet clear of moving parts. DO NOT stick fingers into a pump when in operation. Check suction strainer and hose regularly for proper submergence and to be sure it is free of obstructions.

NEVER operate a self-priming pump unless the volute is filled with liquid. The pump will not prime when dry.

PUMP only liquids for which the pump has been designed to handle.

DO NOT pump flammable, corrosive or caustic materials unless the pump and piping are explicitly designed for that purpose.

NOTE the direction of rotation — operation of a pump in the wrong direction can cause the impeller to unscrew and damage the volute case.

A pump should not be operated against a closed valve or other no flow conditions. Refer to the pump manufacturer's recommended practice for start-up, operation and shut-down procedures. **DO NOT** close down or restrict a discharge hose. **Be careful** of discharge hose whipping under pressure.

4

WORK SAFELY – Pumps In General

MAKE CERTAIN that whatever is to be connected to the pump is not subjected to pressures greater than those given in the manufacturer's instructions.

MAKE CERTAIN all connections are securely made and hoses under pressure are secured, with appropriate safety devices, to prevent whipping.

BE AWARE OF LIGHTNING. Stay clear of the pumping equipment during electrical storms. It can attract lightning. (FIG. 10)

OVERHEATING PRECAUTIONS

Overheated pumps can cause severe damage to the equipment and can cause severe physical burns and injury.

Operating a pump with the suction and/or discharge valve closed is a principal cause of overheating. Approach cautiously any pump that has been in operation.

DO NOT remove hoses from a pump until the system is properly cooled to ambient temperature.

DO NOT remove the cover plate or drain plugs from any overheated pump. Allow the pump to cool. Check pump temperature before opening fill port or drain plug.

If overheating of the pump casing occurs:

- **STOP** the pump immediately.
- Allow the equipment to **cool completely**.
- Slowly and cautiously **vent the pump**.
- **Refer to the manufacturer's instruction manual** before restarting the unit.
- Remove hoses carefully. Heated water can be in hoses and static head produces pressure.

4

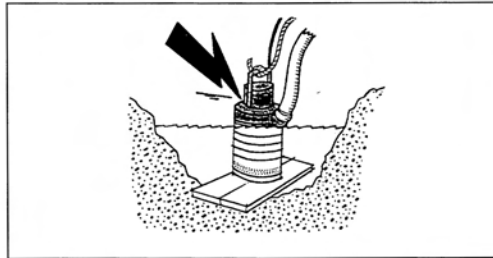

FIG. 10

11

WORK SAFELY – Pumps In General

BEFORE STARTING

Check the pump thoroughly at delivery for any shipping damage.

Locate the pump in an accessible location, as close to the liquid as possible.

Secure the pump after it is placed in its intended operating position so it does not tip, roll, slide or fall.

IMMEDIATELY ON STARTING THE PUMP

Observe gauges, instruments and warning lights to ensure that they are functioning and their readings are within the normal operating range.

- Be sure the immediate work area is safe for operation.
- Operate controls; make certain all operate properly and "feel" right. Accustom yourself to the "feel" of the equipment.
- Listen for any unusual noises, smell for any unusual odors; look for any signs of trouble.
- Be sure to open all manual valves slowly to prevent WATER HAMMER.
- Check all warning and safety devices and indicators.

• If safety-related defects or malfunctions are detected, **SHUT DOWN** the equipment. Correct the problem, or notify your supervisor. **DO NOT OPERATE EQUIPMENT WITH DEFECTS OR MALFUNCTIONS UNTIL CORRECTED.**

• **If an unsafe condition cannot be remedied immediately, notify your supervisor and tagout/lockout** the pump on the start switch and/or appropriate, prominent location. (FIG. 11)

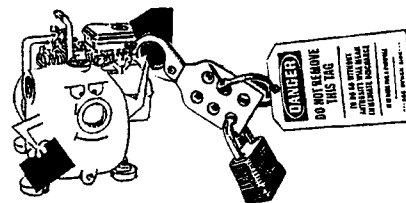

FIG. 11

4

WORK SAFELY – Engine Driven Pumps

SAFE WORKING PROCEDURES

Do not jump start engine battery.

When operating internal combustion engines in an enclosed area, always make provisions to pipe exhaust fumes to the outside.

EXHAUST FUMES CAN KILL: Do not operate engine driven pump equipment in a confined or enclosed space without adequate ventilation.

Exhaust gases are odorless and deadly poison.

DO NOT TOUCH: The exhaust system components get very hot and stay hot for some time after shutting the engine off.

Follow engine manufacturer's instructions explicitly on hand cranking.

Do not shut down high head pumps quickly:

- A) Throttle back slowly
- B) Open by-pass line
- C) Should have a check valve
- D) Slowly close gate valve on discharge if so equipped.

Check for fuel, oil and hydraulic fluid leaks, worn and damaged hoses/lines or power cables.

Refueling

When refueling, the following precautions must be followed:

- Add fuel of proper type and grade, only when the pump is not running and engine is cool.
- Fuel in well ventilated area.
- Turn off all electrical switches.
- Keep lighted smoking materials, flames or spark producing devices at a safe distance while refueling.
- Keep fuel nozzle in contact with tank being filled, or provide a ground to prevent static sparks from igniting fuel.
- **Do not spill fuel on hot surfaces.**
- Clean up spillage immediately.
- Do not start engine until fuel cap is secured to the fuel tank.
- **Always** make sure that fuel is being put in the fuel tank, motor oil in the proper location and hydraulic oil into hydraulic oil reservoirs.

5

13

WORK SAFELY – Engine Driven Pumps

Maintenance and Repair

All installations, operations and maintenance should be in accordance with pump and engine manufacturer's recommended operation and maintenance program. These manuals should be kept available with the equipment.

Maintenance work can be **hazardous** if not done in a careful manner. All personnel should realize the hazards and strictly follow safe practices.

NEVER perform any work on the equipment unless authorized to do so.

BEFORE ANY maintenance **work** is to be done, a LOCKOUT/TAGOUT standard device and procedure should be implemented. Prior to removal of LOCKOUT/TAGOUT, the equipment must be fully operational and all personnel accounted for. Except in cases of emergency, the removal of the LOCKOUT/TAGOUT should be done **ONLY** by the initiating person prior to the return to start-up (see page 12, Fig. 11).

BEFORE doing any major work, disconnect the ignition and battery if so equipped.

Always replace safety devices removed during service or repair before returning pump to operation.

Battery Servicing

- **Always wear** safety glasses and gloves when servicing or working with batteries.
- **Before servicing battery**, turn off electrical systems, then disconnect ground terminal clamp. Before installing a battery, turn off electrical equipment, then connect the battery ground clamp **last**.
- **Maintain** electrolyte at the recommended level. Check level frequently. Add distilled water to batteries only when starting up, never when shutting down.
- **Use a flashlight** to check level. **NEVER** use a flame.
- **Do not short** across battery terminals — the spark could ignite the battery gases.

Battery acids will **burn skin**, eat holes in clothing, and can **cause blindness** if splashed in eyes.

If you spill acid on yourself flush skin immediately with lots of water. Apply baking soda to help neutralize the acid. If acid gets into the eyes, flush immediately with large amounts of water and seek proper medical treatment immediately.

5

14

WORK SAFELY – Electric Motor Driven Pumps

SAFE WORKING PROCEDURES

Allow only qualified personnel to INSTALL, WIRE AND OPERATE electric motor driven pumps. Whenever electricity is present there is the possibility of **electrocution**.

NEVER use a pump/motor in an explosive atmosphere if it is not exclusively designed for the application.

Always ground electrical units.

Make certain to connect pump motor to the right phase and voltage.

Do not run pump if voltage is not within limits.

Make sure motor rotation is in accordance with impeller rotation (which should be indicated somewhere on the pump — check the manufacturer's manual).

Make all electrical installations in accordance with National Electric Code, State and Local electrical codes.

Never use gas piping as an electrical ground.

Make sure the related electrical circuits are dead and locked out before performing any maintenance.

Follow motor manufacturer's recommended maintenance and operation instructions.

If circuit breaker or fuse is tripped, examine the system for the problem before restarting pump.

NEVER use the power cord to aid lifting the pump.

NEVER operate a pump with a plug-in type power cord without a ground fault circuit interrupter.

NEVER use cords with frayed, cut or brittle insulation. Check the cord on the pump for nicks in the insulation and for sound connections to the ground fault interrupter plug and motor.

NEVER let extension cords or the plug connections lay in water. Locate the pump so that the cord cannot fall into any water or be submerged by rising water, unless the pump is designed for such use.

NEVER handle energized power cords with wet hands.

MOTOR OVERLOAD: do not exceed the manufacturer's recommendation for maximum lift or discharge head. See manufacturer's published curve for proper sizing of motors. A misapplied motor can overheat.

6

15

WORK SAFELY – Electric Motor Driven Pumps

Pump Maintenance and Repair

MAKE SURE the pump is disconnected from the power source or the appropriate circuits are dead and OSHA Lockout/Tagout is applied before doing any maintenance or repair work on the pump.

Maintenance work can be **hazardous** if not done in a careful manner. All personnel should realize the hazards and strictly follow safe practices.

NEVER perform any work on the equipment unless authorized to do so. (FIG. 11) Before performing any maintenance or repair work, consult the manufacturer's instruction manual for recommended procedures.

Pumps with float switches or other automatic devices can start without warning if not properly locked out.

BEFORE ANY maintenance work is to be done, a LOCKOUT/TAGOUT standard device and procedure should be implemented. Prior to removal of LOCKOUT/TAGOUT, the equipment must be fully operational and all personnel accounted for. Except in cases of emergency, the removal of the LOCKOUT/TAGOUT should be done **ONLY** by the initiating person prior to the return to start-up.

ALWAYS replace safety devices removed during the service or repair before returning pump to operation.

NEVER use the power cord to aid in lifting the pump.

Sizing Extension Cords

Use the following chart to select the correct size extension cord to prevent excessive amperage draw or voltage drop which would cause the motor to overheat. **Cables that are too long or coiled** can cause a voltage drop. **Be aware** that strong sunlight can cause a voltage drop.

Amperes	Wire Gauge and Cord Length (in feet)		
	50	100	150
6	16	16	14
8	16	14	12
10	16	14	12
12	14	14	12
14	14	12	10
16	12	12	10

6

16

WORK SAFELY – Submersibles

SAFE WORKING PROCEDURES

ALLOW only qualified personnel to INSTALL, WIRE and OPERATE submersible pumps.

Whenever electricity is present there is the possibility of **electrocution**.

NEVER use a pump/motor in an explosive atmosphere, if it is not exclusively designed for that application.

ALWAYS ground the pump.

Make certain to connect the pump to the right phase and voltage.

DO NOT run the pump if voltage is not within limits. **Make all electrical installations** in accordance with National Electric Code, State and Local electrical codes.

Mount electrical control box in a vertical position, protected from the elements.

NEVER attempt to use the power cord or hydraulic hoses as a lifting or lowering device for submersibles. Attach a lifting cable to the manufacturer's recommended attachment point on the pump for lowering and lifting the pump. (FIG. 12)

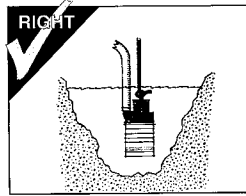

FIG. 12

NEVER position the pump directly on a soft, loose bottom. To attain maximum capacity and prevent excessive wear, position the pump so it will not burrow itself into sand or clay. Stand the pump on a plank, a bed of coarse gravel, within a perforated container, on a suitable floatation device, or retain it hanging freely by a lifting cable. (FIG. 13)

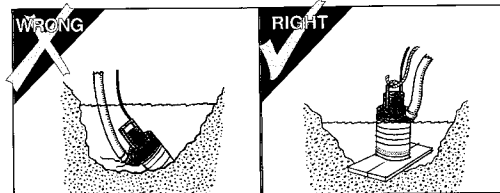

FIG. 13

7

17

WORK SAFELY – Submersibles

Pump Maintenance and Repair

MAKE SURE the pump is disconnected from the power source or the appropriate circuits are dead and OSHA Lockout/Tagout is applied before doing any maintenance or repair work on the unit.

Maintenance work can be **hazardous** if not done in a careful manner. All personnel should realize the hazards and strictly follow safe practices.

NEVER perform any work on the equipment unless authorized to do so. Before performing any maintenance or repair work, consult the manufacturer's instruction manual for recommended procedures.

BEFORE ANY maintenance work is to be done, a LOCKOUT/TAGOUT standard device and procedure should be implemented. Prior to removal of LOCKOUT/TAGOUT, the equipment must be fully operational and all personnel accounted for. Except in cases of emergency, the removal of the LOCKOUT/TAGOUT should be done **ONLY** by the initiating person prior to the return to start-up.

Check oil level ONLY when pump is cool.

USE ONLY recommended oil per manufacturer's recommendation.

INSPECT ELECTRICAL WIRING for worn or damaged insulation. **INSTALL** new wiring if wires are damaged. **After repairs are made, clean the equipment before putting the pump back into position.**



7

TEST YOUR KNOWLEDGE

Do you understand this AEM SAFETY MANUAL AND ITEMS SUCH AS ...

- Your safety program?
 - Your pump manufacturer's manual(s)?
 - Proper clothing and personal safety equipment?
 - Your pump's controls, warning signs and devices, and safety equipment?
 - How to properly inspect, mount, and start your pump?
 - How to check your pump for proper operation?
 - Your work area and any special hazards that may exist?
- Proper operating procedures?
 - Proper shutdown procedures?
 - Proper maintenance procedures?
 - Proper loading and unloading procedures for transporting?
 - Under what conditions you should not operate your pump?

If you do not understand any of these items, consult with your supervisor BEFORE operating your equipment!

8

19

FINAL WORD TO THE USER

Remember that **YOU are the key to safety**. Good safety practices not only protect you but protect the people around you.

You have read this safety manual and the manufacturer's manual(s) for your specific pump. Make them a working part of your safety program. Keep in mind that this safety manual is written for only this type of equipment.

Practice all other usual and customary safe working precautions, and above all —

**REMEMBER
SAFETY IS UP TO YOU
YOU CAN PREVENT SERIOUS
INJURY OR DEATH**

9

20

This manual is another in a series on the safe operation of machinery published by AEM.
For additional publications visit our web site at www.aem.org.



Association of Equipment Manufacturers

Toll free 1-866-AEM-0442

e-mail aem@aem.org

www.aem.org

Important: For spare parts information, please see your Wacker Neuson Dealer, or visit the Wacker Neuson website at <http://www.wackerneuson.com/>.

Wichtig! Informationen über Ersatzteile erhalten Sie von Ihrem Wacker Neuson Händler oder besuchen Sie die Wacker Neuson Website unter <http://www.wackerneuson.com/>.

Important : Pour des informations sur les pièces détachées, merci de consulter votre distributeur Wacker Neuson, ou de visiter le site Internet de Wacker Neuson sur <http://www.wackerneuson.com/>.

Importante : Para saber más sobre las piezas de repuesto, póngase en contacto con su distribuidor de Wacker Neuson o acceda al sitio web de Wacker Neuson en <http://www.wackerneuson.com/>.

Importante : Per informazioni sui pezzi di ricambio, contattare il rivenditore Wacker Neuson o visitare il sito di Wacker Neuson all'indirizzo www.wackerneuson.com.

Viktigt : För information om reservdelar, kontakta din Wacker Neuson-leverantör eller besök Wacker Neusons webbplats på <http://www.wackerneuson.com/>.

Tärkeää : Pyydä varaosatietoja Wacker Neusonin jälleenmyyjältä tai vieraile Wacker Neusonin web-sivustolla osoitteessa <http://www.wackerneuson.com/>

Viktig : For informasjon om reservedeler, vennligst kontakt din Wacker Neuson-forhandler, eller besøk Wacker Neusons nettside på <http://www.wackerneuson.com/>.

Viktigt : Hvis du ønsker oplysninger om reservedele, bedes du kontakte din Wacker Neuson forhandler eller besøg Wacker Neuson websiden på <http://www.wackerneuson.com/>.

Belangrijk! Neem contact op met uw Wacker Neuson dealer of bezoek de website van Wacker Neuson op <http://www.wackerneuson.com/> voor meer informatie over reserveonderdelen.

Importante : Para obter informações sobre as peças sobresselentes, consulte o seu fornecedor da Wacker Neuson ou acesse ao site Web da Wacker Neuson em http://www.wackerneuson.com

Ważne : W celu uzyskania informacji na temat części zamiennych skontaktuj się z przedstawicielem firmy Wacker Neuson lub skorzystaj z witryny internetowej <http://wackerneuson.com/>.

Důležitě upozornění! Pro informace o náhradních dílech, prosím, kontaktujte svého Wacker Neuson dealera, nebo navštivte webové stránky <http://www.wackerneuson.com/>.

FONTOS: A pótalkatrészekre vonatkozó információkért kérjük, forduljon Wacker Neuson kereskedőjéhez vagy látogasson el a Wacker Neuson weboldalára a következő címen: <http://www.wackerneuson.com/>.

Важно! Для ознакомления с информацией о запасных частях, пожалуйста, обратитесь к местному торговому представителю компании Wacker Neuson или посетите веб-сайт <http://www.wackerneuson.com/>.

Σημαντικό : Για πληροφορίες σχετικά με τα ανταλλακτικά, μιλήστε με τον αντιπρόσωπό σας της Wacker Neuson, ή επισκεφθείτε τον ιστότοπο <http://www.wackerneuson.com/>.

Važno : Za rezervne dijelove obratite se svom Wacker Neuson prodavaču ili posjetite mrežne stranice tvrtke Wacker Neuson: <http://www.wackerneuson.com/>.

Önemli : Yedek parça bilgileri için Wacker Neuson Bayinize bakın veya Wacker Neuson web sitesini ziyaret edin. <http://www.wackerneuson.com/>

重要 交換部品の情報については、ワッカーノイソンディーラーにお問い合わせ頂くか、ワッカーノイソンウェブサイト <http://www.wackerneuson.com/> をご覧ください。

重要 有关备件信息，请咨询您的威克诺森经销商或访问威克诺森网站：
<http://www.wackerneuson.com/>。

Important : Pentru informații referitoare la piesele de schimb, vă rugăm să vă adresați distribuitorului Wacker Neuson sau să vizitați site-ul web Wacker Neuson la adresa <http://www.wackerneuson.com/>.

Важно : За информация относно резервни части, моля, обърнете се към местния дилър на Wacker Neuson или посетете уебсайта на Wacker Neuson на адрес <http://www.wackerneuson.com/>.

Wacker Neuson Produktion GmbH & Co. KG, Preußenstraße 41, D-80809 München,

Tel.: +49-(0)89-3 54 02-0 Fax: +49 - (0)89-3 54 02-390

Wacker Neuson Production Americas LLC, N92W15000 Anthony Ave., Menomonee Falls, WI. 53051

Tel.: (262) 255-0500 Fax: (262) 255-0550 Tel.: (800) 770-0957

Wacker Neuson Limited - Room 1701-03 & 1717-20, 17/F, Tower 1, Grand Century Place, 193 Prince Edward Road West, Mongkok, Kowloon, Hongkong. Tel: (852) 3605 5360, Fax: (852) 2758 0032