

Tele-Tower®

Adjustable Work Platform

OPERATOR'S MANUAL

**For Models
1101-22 & 1101-2296**
(Model 1101-22 illustrated in this manual)



⚠️ WARNING ⚠️

Read and become familiar with this manual **BEFORE** operating unit.

Before operating this equipment, thoroughly read this set of instructions, make sure you understand them, and only then follow the step-by-step directions. Failure to do so could result in serious property damage and / or serious bodily injury or death.

MADE IN USA BY **PARAGON PRO**
MANUFACTURING SOLUTIONS

To our valued customer,

Thank you for choosing a **Telpro Inc.**[®] product by **PARAGON PRO** Manufacturing Solutions. We are pleased that we are able to provide equipment to make your work easier.

Our efforts are focused on producing the finest quality equipment of which we are capable. We make sure to spend extra time and effort on our design and production in order to reduce your time and effort spent using the product.

We take pride in providing the best for our customers. Quality, innovation, and excellence are all qualities this company ensures. No product is sent without being factory tested and inspected to ensure the highest quality for you.

It all began in 1972 when Roland Young designed our first product, the PANELLIFT[®] Brand Drywall Lift, and revolutionized the drywall industry. To this day we are continuously making advancements in manufacturing and design.

Thank you again for giving us the opportunity to work with you. Any questions or comments that you have are always welcome.

PARAGON PRO
M a n u f a c t u r i n g S o l u t i o n s

This manual covers TELE-TOWER® Adjustable Work Platform Models 1101-22 and 1101-2296.

*NOTICE: All contents of this manual are copyrighted and nothing may
be reprinted in whole or in part without prior written permission.*

Warning / Instructional Information.	Pages 1-2
User Components & Product Specifications	Page 3
Care & Maintenance.	Page 4
Assembly	Pages 5-7
Operation	Pages 8-9
ASME Standards for Wire Rope	Page 10
Parts Index	Pages 11-12

⚠ Warning ⚠

Read and follow these warnings and the instructions that follow. Failure to do so could result in serious property damage and/or serious bodily injury.

• **BEFORE** operating this equipment, thoroughly read this set of instructions, make sure you understand them, and only then follow the step-by-step directions.

FAILURE TO READ AND FOLLOW THESE INSTRUCTIONS could result in failure of the equipment. Failure of the equipment while the platform is raised can include a sudden and rapid lowering of the platform and load possibly resulting in serious property damage and/or serious bodily injury or death.

• Use and maintenance of the Tele-Tower® Adjustable Work Platform shall be limited to authorized personnel who are trained in the proper techniques for its safe operation and maintenance and who are familiar with the various hazards of using overhead access equipment.

• Such training shall be the responsibility of the equipment owner under the direction of a designated Competent Person as defined by OSHA [29 CFR 1926.32(f)].

• It shall be the responsibility of any and all users of the Tele-Tower® Adjustable Work Platform to:

- Become familiar with all aspects of assembly, operation and necessary safety precautions
- Become familiar and comply with all federal, state and local statutes, regulations, and/or codes.

• **READ AND COMPLY** with the most current version of **ANSI Standard A10.8**,

• **DO NOT ATTEMPT TO USE YOUR Tele-Tower® Adjustable Work Platform IF ANY PART IS MISSING, DAMAGED OR WORN. ORDER A REPLACEMENT PART IMMEDIATELY.** Using a Tele-Tower® Adjustable Work Platform with missing, damaged or worn components can result in failure of the unit and possibly severe property damage and/or serious bodily injury or death.

• **DANGER!** The Tele-Tower® Adjustable Work Platform is made of steel which conducts electricity. **KEEP THE UNIT AWAY FROM LIVE ELECTRICAL WIRES.** Failure to do so could result in electrocution.

• **The weight capacity of the Tele-Tower® Adjustable Work Platform is 550 lbs. (249 kg). DO NOT load the unit beyond this limit.** Failure to follow this warning can result in damage to the Tele-Tower® Adjustable Work Platform contributing to a sudden failure of the equipment and serious property damage and/or serious bodily injury or death.

• The Tele-Tower® Adjustable Work Platform shall be used only on hard, flat (slope not greater than 1/4 inch per foot) surfaces free of obstructions, openings, pits and/or holes. Operate at room temperature, avoid humidity and water.

• **DO NOT** extend working heights by standing on toe boards, guardrails, planking guardrails, or by use of boxes or ladders or other devices on the work platform.

• **USE ONLY** factory authorized accessories and replacement parts. Installation or use of other parts can compromise the safe design of the Tele-Tower® Adjustable Work Platform and may cause failure of the unit possibly resulting in serious property damage and/or serious bodily injury.

• Work only from the platform area of the Tele-Tower® Adjustable Work Platform. Use caution when reaching over or outside the guard rail system to access work. Over extending can create a fall hazard.

• **DO NOT** extend the length or width of the Tele-Tower® Adjustable Work Platform beyond the manufacturer's supplied design.

• **DO NOT** lay decks, planks, or any other form of staging or platform across the toe boards of the Tele-Tower® Adjustable Work Platform. Damage to the toe boards may result, making the Tele-Tower® unsafe.

• Persons climbing or descending the Tele-Tower® Adjustable Work Platform shall have both hands free for climbing and shall remove foreign substances such as, but not limited to, mud or grease, from their shoes and hands.

• **DO NOT** attach any form of hoisting device to the Tele-Tower® Adjustable Work Platform that is not designed by Telpro Inc. specifically for use on the Tele-Tower® Adjustable Work Platform.

• When workers are at work on the Tele-Tower® Adjustable Work Platform and an overhead hazard exists, overhead protection shall be provided and shall be positioned not more than 9 feet above the work platform.

• Workers shall not work on the Tele-Tower® Adjustable Work Platform during storms or high winds, as determined by a competent person.

• Tools, materials and debris shall not be allowed to accumulate so as to create a hazard on the Tele-Tower® Adjustable Work Platform.

• **DO NOT** use the Tele-Tower® Adjustable Work Platform in or near work involving corrosive substances, acids, chemical, or corrosive atmospheres. Doing so can cause damage to the cable elevating system and/or other components possibly resulting in failure which may result in severe property damage and/or severe bodily injury.

• **DO NOT** use the Tele-Tower® Adjustable Work Platform in wet environments, doing so may cause the caster brakes or other components to malfunction or fail, possibly resulting in severe property damage and/or severe bodily injury or death.

• Special precautions shall be taken to protect the Tele-Tower® Adjustable Work Platform components including the cable elevating system when a heat-producing process is in use, such as: welding, grinding, torching, etc. The Tele-Tower® Adjustable Work Platform components that have been contacted by any heat-producing process shall be considered to be permanently damaged and shall be replaced with new components before the Tele-Tower® Adjustable Work Platform is used.

Questions? - Call Paragon Pro Manufacturing Solutions Customer Service at 1-800-448-0822 or 701-775-0551

⚠ Warning ⚠

Read and follow these warnings and the instructions that follow. Failure to do so could result in serious property damage and/or serious bodily injury.

- **NEVER** make height adjustments while a person is on the platform. Doing so can subject the cable lift assembly to stresses and loads that it was not designed to carry. This can result in failure of the assembly which may include a sudden and rapid lowering of the platform possibly resulting in serious property damage and/or serious bodily injury or death. The Tele-Tower® Adjustable Work Platform is not a personnel lift and shall not be used as such.

- **BE OBSERVANT OF ANY POTENTIALLY HAZARDOUS CONDITIONS INCLUDING BUT NOT LIMITED TO:**

- Any obstructions
- Loose materials
- Moving machinery
- Open ducts
- Wires
- Holes
- Electrical installations
- Stairwells
- Changes in floor elevations
- Etc.

Before Climbing - After Assembling or Readjusting the Equipment:

- **ALWAYS** be sure that all four ladder lock pins are properly engaged before climbing. Failure to do so can subject the cable lift assembly to stresses and loads that it was not designed to carry. This can result in failure of the assembly which may include a sudden and rapid lowering of the platform possibly resulting in serious property damage and/or serious bodily injury or death.

- **INSPECT THE CABLE BEFORE EACH USE.**

- **REPLACE AT THE FIRST SIGN OF WEAR.** A worn, damaged or improperly installed cable can fail resulting in a sudden and rapid lowering of the platform possibly resulting in serious property damage and/or serious bodily injury or death. (See page 10 for general standards for cable inspection.)
- **MAKE SURE** the cable is properly strung through the ladder sheaves and properly attached at the anchor points on the ladder frames.

- **ALWAYS** be sure that the base outriggers are adjusted to maintain a height to base ratio in accordance with ANSI, A10.8 and all applicable federal, state and local codes.

Before Climbing - Each Time the Equipment is Accessed:

- **BE SURE** that:
 - the Tele-Tower® Adjustable Work Platform is correctly assembled
 - all four ladder lock pins are fully engaged and the cable is properly strung and taut under the sheaves
 - the base outriggers are extended to maintain a height to base ratio in keeping with applicable federal, state, and local standards
 - all four casters are securely installed with bolts and brakes are set and properly functioning
 - all guardrails, chains and anti-sway braces are correctly and securely installed
 - safe access is provided
 - there are no overhead obstructions or live electrical lines within 12 feet of the work platform

When moving the Tele-Tower® Adjustable Work Platform:

- **DO NOT** move the Tele-Tower® Adjustable Work Platform by pulling on overhead structures such as beams, pipes, trusses, etc. from the top. Doing so can result in tipping of the platform possibly resulting in severe property damage and/or severe bodily injury or death.
- **BEFORE MOVING** secure or remove all materials, tools, and equipment.
- **ALWAYS** adjust base outriggers to maintain a height to base ratio in accordance with ANSI, A10.8 and all applicable federal, state and local codes.
- The force used to move the Tele-Tower® Adjustable Work Platform shall be applied as close to the base as practicable, and provision shall be made to stabilize the tower during movement from one location to another.
- Persons shall be prohibited from riding on the Tele-Tower® Adjustable Work Platform while it is being moved unless the following conditions exist:
 - The surface on which the Tele-Tower® is being moved is hard, flat (slope not greater than 1/4 inch per foot), and free of obstructions, openings, pits and/or holes.
 - The height to base ratio of the Tele-Tower® is two to one or less.
 - Persons on the work platform shall be advised of and be made aware of each movement in advance and shall remain only on the deck of the work platform.
 - No person is on any part of the Tele-Tower® which extends outward beyond the casters or other supports.
- **DO NOT** attach any form of ground drive device to the Tele-Tower® Adjustable Work Platform that is not designed by Telpro Inc. specifically for use on the Tele-Tower® Adjustable Work Platform Model 1101-22 or 1101-2296.
- Be sure there are no overhead obstructions or electric power lines in the path of the rolling work platform.
- When using the 1177-22 or 1177-2296 Tele-Tower® Extension, work only from the top platform. The lower platform is not designed as a work area.
- **ALWAYS** fully disassemble the Tele-Tower® Adjustable Work Platform before transporting

Questions? - Call Paragon Pro Manufacturing Solutions Customer Service at 1-800-448-0822 or 701-775-0551

USER COMPONENTS & SPECIFICATIONS

- A. Telescoping end section “A” with integral outriggers
- B. Telescoping end section “B” with integral outriggers
- C. 5” heavy-duty swivel / brake scaffold casters
- D. Connecting beam with cable elevation mechanism
- E. Guard rails (4)
- F. Safety Chains (4)
- G. Interchangeable anti-sway braces (6)
- H. Steel safety deck with 4” toe board
 - Model 1101-22 & 1177-22: (approx. 22” x 6 feet)
 - Model 1101-2296 & 1177-2296: (approx. 22” x 8 feet)

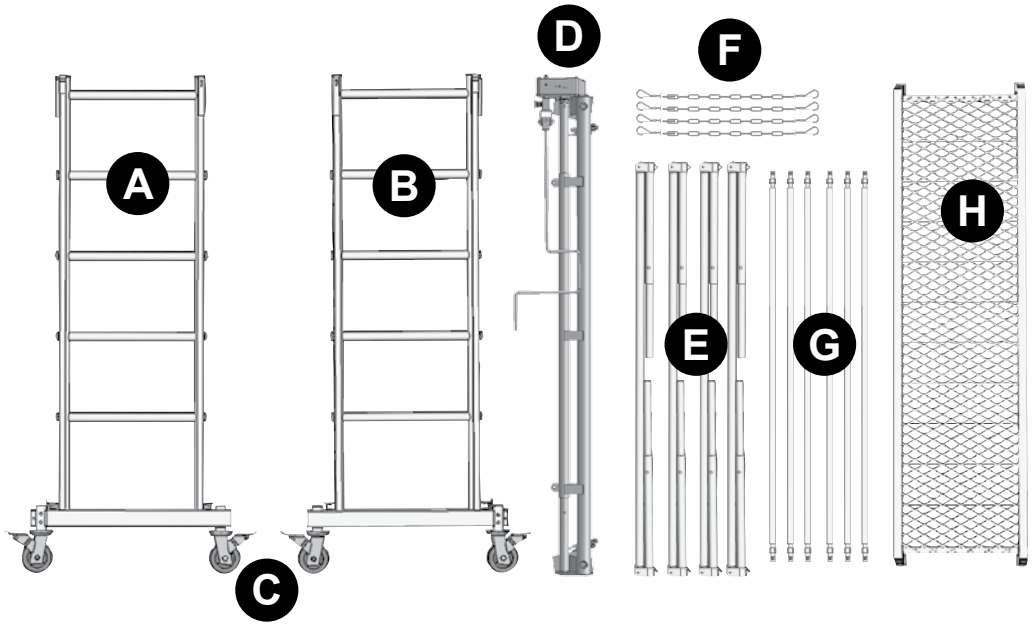

	Tele-Tower® Work Platform models 1101-22 & 1101-2296	Optional Extension Installed models 1177-22 & 1177-2296*
STATIC LOAD RATING	800 lbs. (362 kg)	800 lbs. (362 kg)
DECK HEIGHT	2' TO 11' in 6" increments	12.5' TO 17.5' in 6" increments
MAX WORKING HEIGHT	Approx. 17.5' (5.3 m)	Approx. 24' (7.3 m)

ALWAYS adjust the base outriggers to maintain a height to base ratio in accordance with federal, state, and local standards.

* When using the 1177-22 or 1177-2296 Tele-Tower® Extension, work only from the top platform. The lower platform is not designed as a work area.

!

DO NOT EXCEED STATIC LOAD RATING OF 800 Lbs.



- **Inspect cable FREQUENTLY. (At least daily and before each use)
Replace at the first sign of wear. (See Warnings on pages 1 & 2)**
- **Occasionally oil all spring pins and cable sheaves.**
- **Lubricate caster bearings and ensure proper function of caster brakes and locks.**
- **Remove foreign substances from base outriggers for smooth operation.**
- **Apply household paraffin to the base outriggers and to the vertical surfaces of the telescoping ladders, for smoother action.**
- **Store the Tele-Tower® Adjustable Work Platform in a dry place.**
- **Take reasonable care to avoid damaging the Tele-Tower® Adjustable Work Platform when transporting it.**
- **Do not hammer on any members or components of the Tele-Tower® Adjustable Work Platform.**

ASSEMBLY

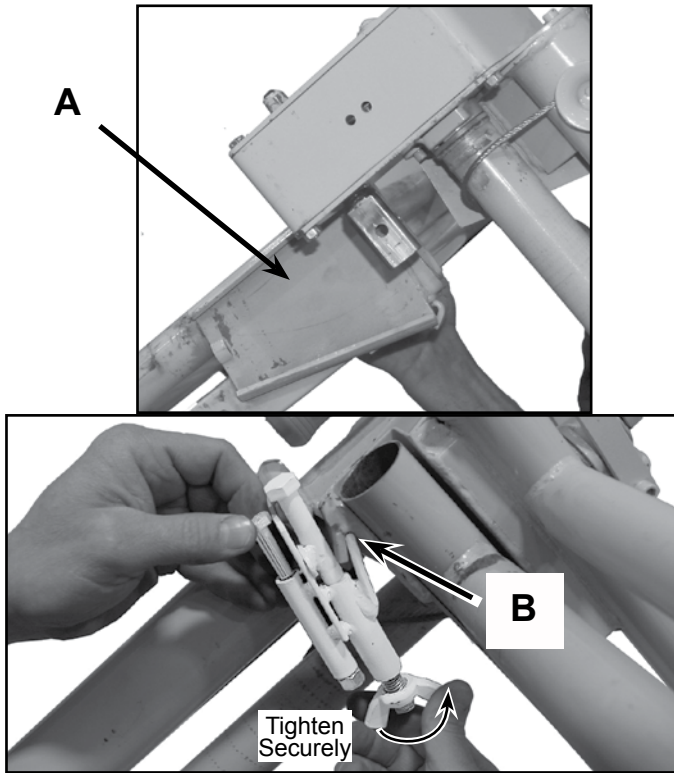

- 1A) Place connecting beam in tapered socket and secure with bolt and wing nut as shown.
- 1B) Lift retaining bolt and tighten wingnut until secure. (Make sure that blade is secure in slot)

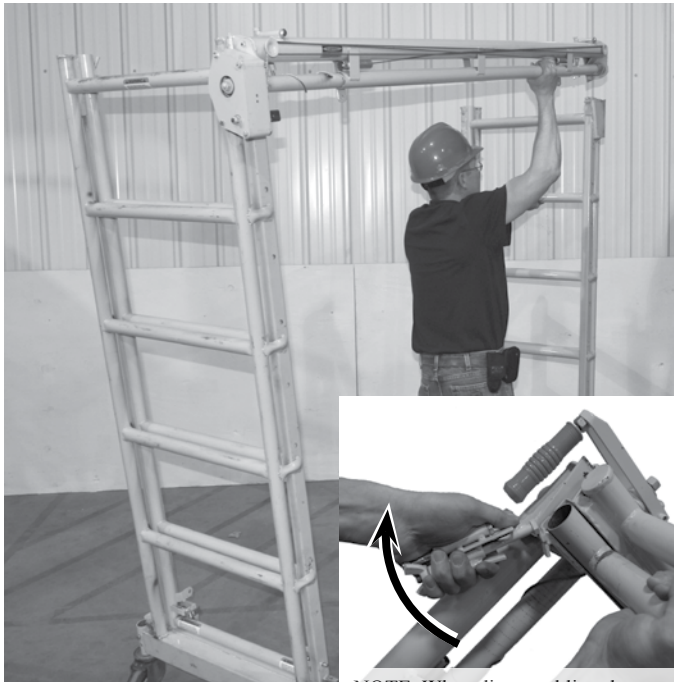

NOTE: When disassembling, loosen wing nut and pivot latch bolt assembly to pry tapered socket open.

- 2) Engage ladder lock pins and lock one caster on end Section "B". Allow casters on Section "A" to roll while connecting to Section "B." Similarly secure as shown in step 1. Secure with bolt and wing nut.

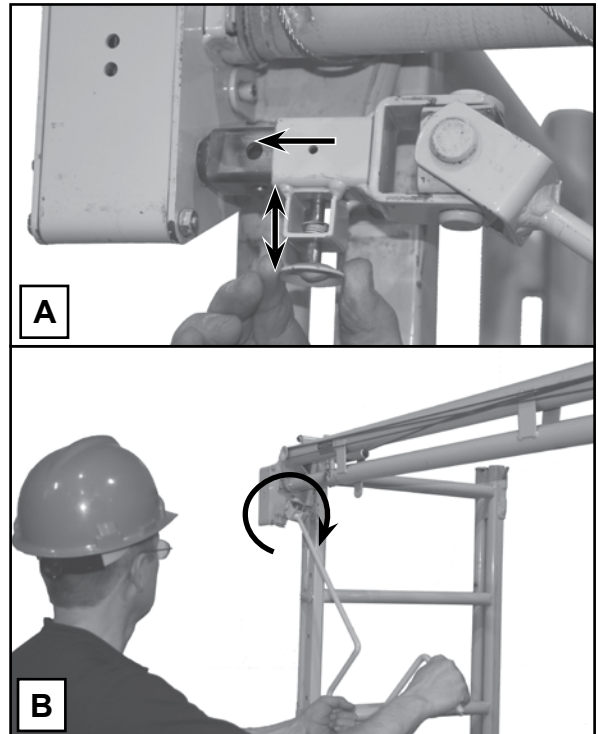

- 3A) Attach winch handle to the input shaft. Secure in place with the pull pin.
- 3B) Rotate winch handle and release cable from storage on beam.



- 4) Place cable under sheave at lower end of each telescoping ladder section.

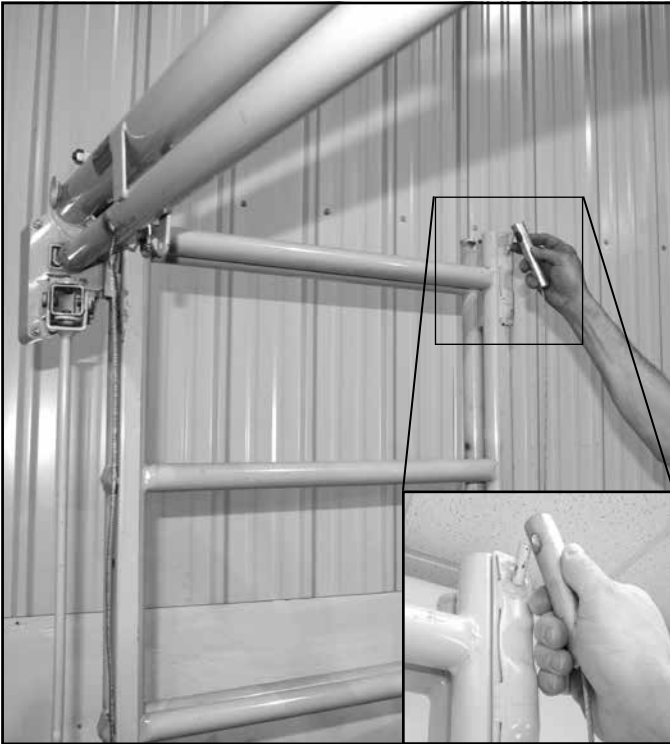

5) Attach cable ends to hooks on top of end sections.

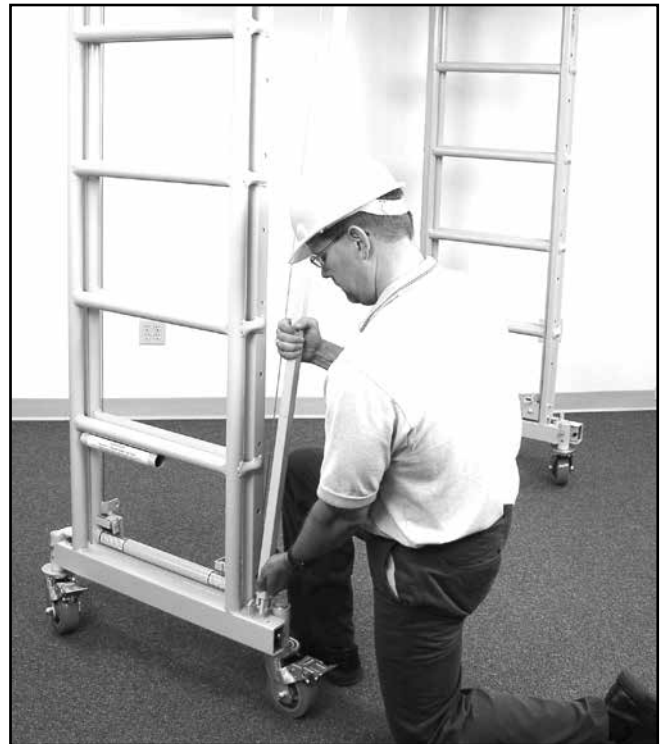

7) Jog base of end sections to facilitate brace pin alignment. **DO NOT** hammer on braces.



6) Attach braces between the beam and the base of each end section. **WARNING:** NEVER operate the Tele-Tower Adjustable Work Platform without these braces. Doing so can result in damage to the structure which can lead to failure that can result in severe property damage and/or severe bodily injury or death.



8) For platform heights from 2' to 6', the deck may be placed on lower rungs. For added safety use guard rails even when deck is on lower rungs.

ASSEMBLY continued



9) For deck heights of 6' or greater, place the deck on the top rungs of the telescoping ladders and attach ALL FOUR deck braces between the deck and the base of the telescoping ladders. Jog base of end sections to facilitate brace pin alignment. **DO NOT** hammer on braces.

WARNING:

NEVER use the Tele-Tower® Adjustable Work Platform at deck heights over 6' without these braces. Doing so can result in damage to the structure which can lead to failure that can result in severe property damage and/or severe bodily injury or death.



10) Install the guard rails in the top of the telescoping ladder sections. **CAUTION:** Keep fingers clear of hinge joints when handling guard rails.



11) Attach all four safety chains between the guard rails on each end.

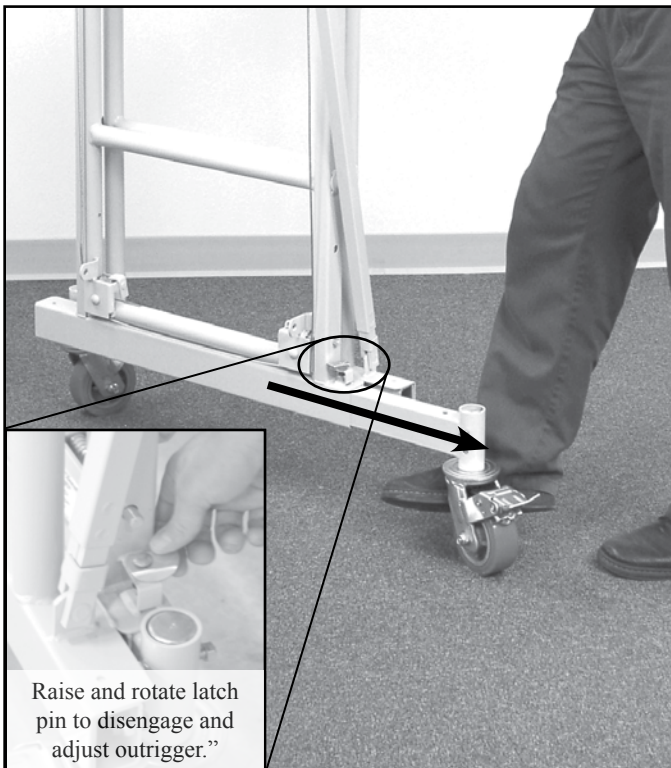

1) Adjust base outriggers to maintain height to base ratio in keeping with applicable national, state, local and ANSI Standards. ALWAYS engage the outrigger latch pin before climbing the Tele-Tower® Adjustable Work Platform.

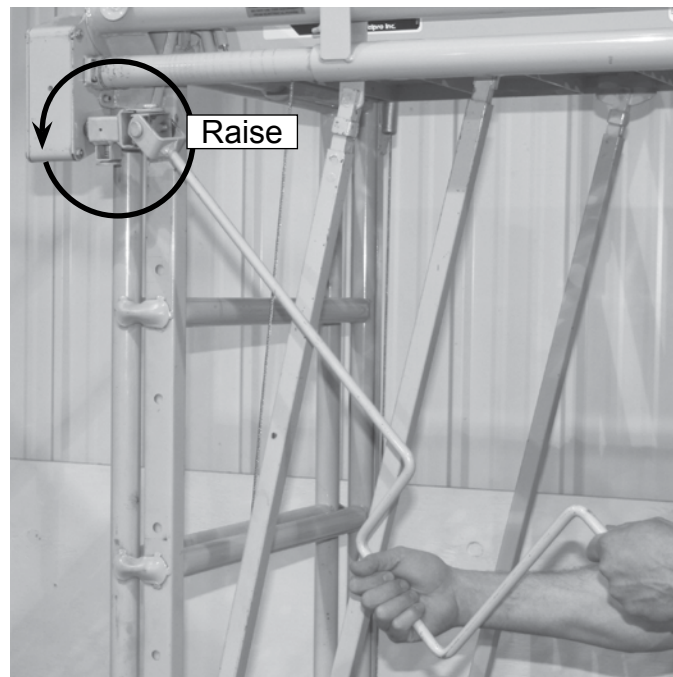

2b) Rotate winch handle counterclockwise until deck is 2" - 4" below the desired height.



2a) TO ELEVATE DECK:
—Retract and rotate the ladder lock spring pins to the disengaged position.



2c) —Return **ALL FOUR** ladder lock spring pins to the engaging position.
—Rotate winch handle further until **ALL FOUR** ladder lock spring pins engage through the holes in the guide channels.

Operation continued



2d) If ladder lock spring pins do not readily engage, raise the cable between the sheaves slightly and jog the telescoping ladder section to help facilitate complete engagement. **DO NOT** pound on the lock pins.

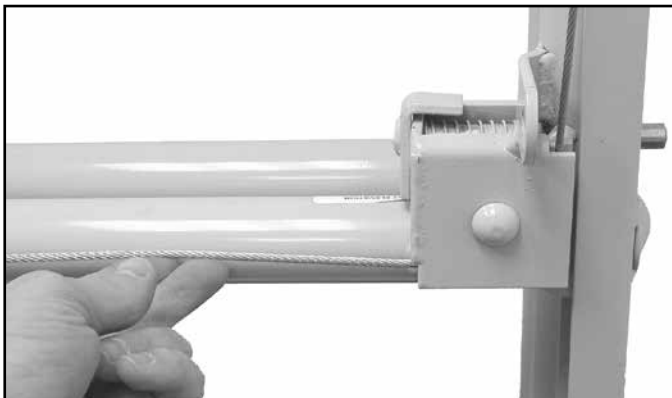

3a) **TO LOWER DECK:**
—Be sure the cable passing under the telescoping ladder sheaves is taut and that the cable is wound evenly at both ends of the winch tube.

WARNING:

- ALWAYS** make sure **ALL FOUR** ladder lock spring pins are fully engaged before climbing.
- NEVER** make height adjustments while a worker is on the work platform. (see warnings, page 1-2.)

WARNING:

While operating the Tele-Tower® Adjustable Work Platform, **ALWAYS** keep the cable taut under the telescoping ladder sheaves. **NEVER rotate the winch handle clockwise while the ladder lock pins are engaged.** Doing so will allow the cable to go slack, which can cause the cable to wind unevenly on the winch tube. This will cause the two telescoping ladders to move unevenly in relation to each other, binding up in the telescoping frame, and will hinder proper and safe locking of the ladder lock spring pins.

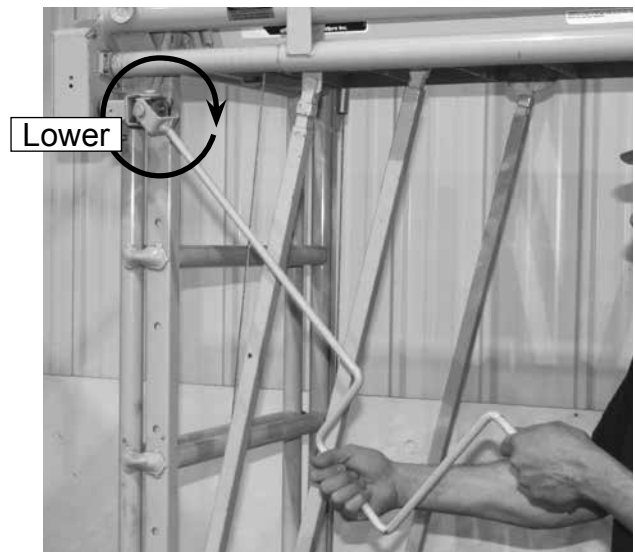

- 3b)
- Retract and rotate the ladder lock spring pins to the disengaged position.
 - Rotate the winch handle clockwise.



Storing the cable:

- Leave one end attached (as when in operation),
- Wind loose end around spools A-B and place spring tube on hook C
 - Detach other end and wind in similar reverse pattern.
 - Take up slack by rotating winch counterclockwise.

ASME Standards for wire rope (cable) inspection and replacement

Reprinted with permission from ASME B30.19 Cableways

The following is intended as a helpful guide to the general topic of inspection and replacement of wire rope (cable). It is not intended to be an exhaustive treatment of the topic. Frequent inspection (at least daily) and prompt replacement of any cable that shows any sign of wear is the responsibility of the owner and the operator of the Tele-Tower® Adjustable Work Platform.

With reference to the chart below at 19-2.4.3(b)(6) the Tele-Tower® Adjustable Work Platform cable is a nominal 1/8" high tensile cable (rope).

(00) General

The use of cableways, cranes, derricks, hoists, hooks, jacks, and slings is subject to certain hazards that cannot be met by mechanical means but only by the exercise of intelligence, care, and common sense. It is therefore essential to have personnel involved in the use and operation of equipment who are competent, careful, physically and mentally qualified, and trained in the safe operation of the equipment and the handling of the loads. Serious hazards are overloading, dropping or slipping of the load caused by improper hitching or slinging, obstructing the free passage of the load, and using equipment for a purpose for which it was not intended or designed.

Section 19-2.4: Rope Inspection, Replacement, and Maintenance

19-2.4.1 General. Sheave diameters, drum diameters, and rope design factors are limited because of cableway design configuration. Due to these parameters, inspection in accordance with para. 19-2.4.2 to detect deterioration and timely replacement in accordance with para. 19-2.4.3 are essential.

19-2.4.2 Inspection

(a) Frequent Inspection

(1) All running ropes in service should be visually inspected once each working day. A visual inspection shall consist of observation of all rope that can reasonably be expected to be in use during the day's operations. These visual observations should be concerned with discovering gross damage that may be an immediate hazard, such as listed below:

(a) distortion of the rope such as kinking, crushing, unstranding, birdcaging, main strand displacement, or core protrusion. Loss of rope diameter in a short rope length or unevenness of outer strands should provide evidence that the rope or ropes are to be replaced.

(b) general corrosion;

(c) broken or cut strands;

(d) number, distribution, and type of visible broken wires [see paras.

19-2.4.3(b)(1), (2), and (7) for further guidance];

(e) core failure in rotation-resistant ropes; when damage is suspected, the rope shall either be removed from service or given an inspection as detailed in para. 19-2.4.2(b).

(2) Care shall be taken when inspecting sections of rapid deterioration, such as flange points, crossover points, and repetitive pickup points on drums.

(3) Care shall be taken when inspecting certain ropes, such as rotation-resistant ropes, because of their higher susceptibility to damage and increased deterioration when working on equipment with limited design parameters. The internal deterioration of rotation-resistant ropes may not be readily observable.

(b) Periodic Inspection

(1) The inspection frequency shall be determined by a qualified person and shall be based on such factors as expected rope life (determined by experience on the particular installation or similar installations), severity of environment, percentage of capacity lifts, frequency rates of operation, and exposure to shock loads. Inspections need not be at equal calendar intervals and should be more frequent as the rope approaches the end of its useful life. The inspection shall be made at least every 1000 hr of cableway operation or annually, whichever comes first.

(2) Periodic inspections shall be performed by an appointed or authorized person. This inspection shall cover the entire length of rope. Only the surface wires of the rope need be inspected. No attempt should be made to open the rope. Any deterioration resulting in appreciable loss of original strength, such as described below, shall be noted, and a determination shall be made as to whether further use of the rope would constitute a hazard:

(a) points listed in para. 19-2.4.2(a):

(b) reduction of rope diameter below nominal diameter due to loss of core support, corrosion, or wear of outside wires;

(c) severely corroded or broken wires at end connections;

(d) severely corroded, cracked, bent, worn, or improperly applied end connections.

(3) Care shall be taken when inspecting sections of rapid deterioration, such as the following:

(a) sections in contact with saddles, equalizer sheaves, or other sheaves, including track cable sheaves, where rope travel is limited;

(b) sections of the rope at or near terminal ends where corroded or broken wires may develop.

19-2.4.3 Rope Replacement

(a) No precise rules can be given for determination of the exact time for rope replacement, since many variable factors are involved. Once a rope reaches any one of the specified removal criteria, it may be allowed to operate to the end of the work shift, based on the judgment of a qualified person. The rope shall be replaced after that work shift, at the end of the day, or at the latest time prior to the equipment being used by the next work shift.

(b) Removal criteria for rope replacement shall be as follows:

(1) In running ropes, six randomly distributed broken wires in one lay, or three broken wires in one strand in one lay.

(2) One outer wire, broken at the contact point with the core of the rope, that has worked its way out of the rope structure and protrudes and loops out from the rope structure. Additional inspection of this section is required.

(3) Wear of one-third the original diameter of outside individual wires.

(4) Kinking, crushing, birdcaging, or any other damage resulting in distortion of the rope structure.

(5) Evidence of heat damage from any cause.

(6) Reductions from nominal diameter greater than those shown below:

Rope Diameter	Max. Allowable Reduction From Nominal Diam.
Up to 5/16 in. (8 mm)	1/64 in. (0.4 mm)
Over 3/8 in. up to 1/2 in. (13 mm)	1/32 in. (0.8 mm)
Over 9/16 in. up to 3/4 in. (19 mm)	3/64 in. (1.2 mm)
Over 7/8 in. up to 1 1/8 in. (29 mm)	1/16 in. (1.6 mm)
Over 1 1/4 in. up to 1 1/2 in. (38 mm)	3/32 in. (2.4 mm)

(7) In standing ropes, more than two broken wires in one lay in sections beyond end connections, or more than one broken wire at an end connection.

(c) Broken wire removal criteria cited in this Volume apply to wire rope operating on steel sheaves and drums. The user shall contact the sheave, drum, or cableway manufacturer, or a qualified person for broken wire removal criteria for wire ropes operating on sheaves and drums made of material other than steel.

(d) Replacement rope shall have a nominal strength rating at least equal to the original rope furnished or recommended by the cableway manufacturer or designer, or a qualified person. Any deviation from the original size, grade, or construction shall be specified by the rope manufacturer, the cableway manufacturer or designer, or a qualified person.

(e) Ropes Not in Regular Use. All rope that has been idle for a period of a month or more due to shutdown or storage of a cableway on which it is installed shall be given an inspection in accordance with para. 19-2.4.2(b) before it is placed in service. This inspection shall be for all types of deterioration and shall be performed by an appointed or authorized person.

(f) Inspection Records

(1) Frequent inspection-no records required.

(2) Periodic inspection - in order to establish data as a basis for judging the proper time for replacement, a dated report of rope condition at each periodic inspection shall be kept on file. This report shall cover points of deterioration listed in para. 19-2.4.2(b)(2).

(g) A long-range inspection program should be established and should include records on examination of rope removed from service so a relationship can be established between visual observation and actual condition of the internal structure.

PARTS INDEX Models 1101-22 & 1101-2296

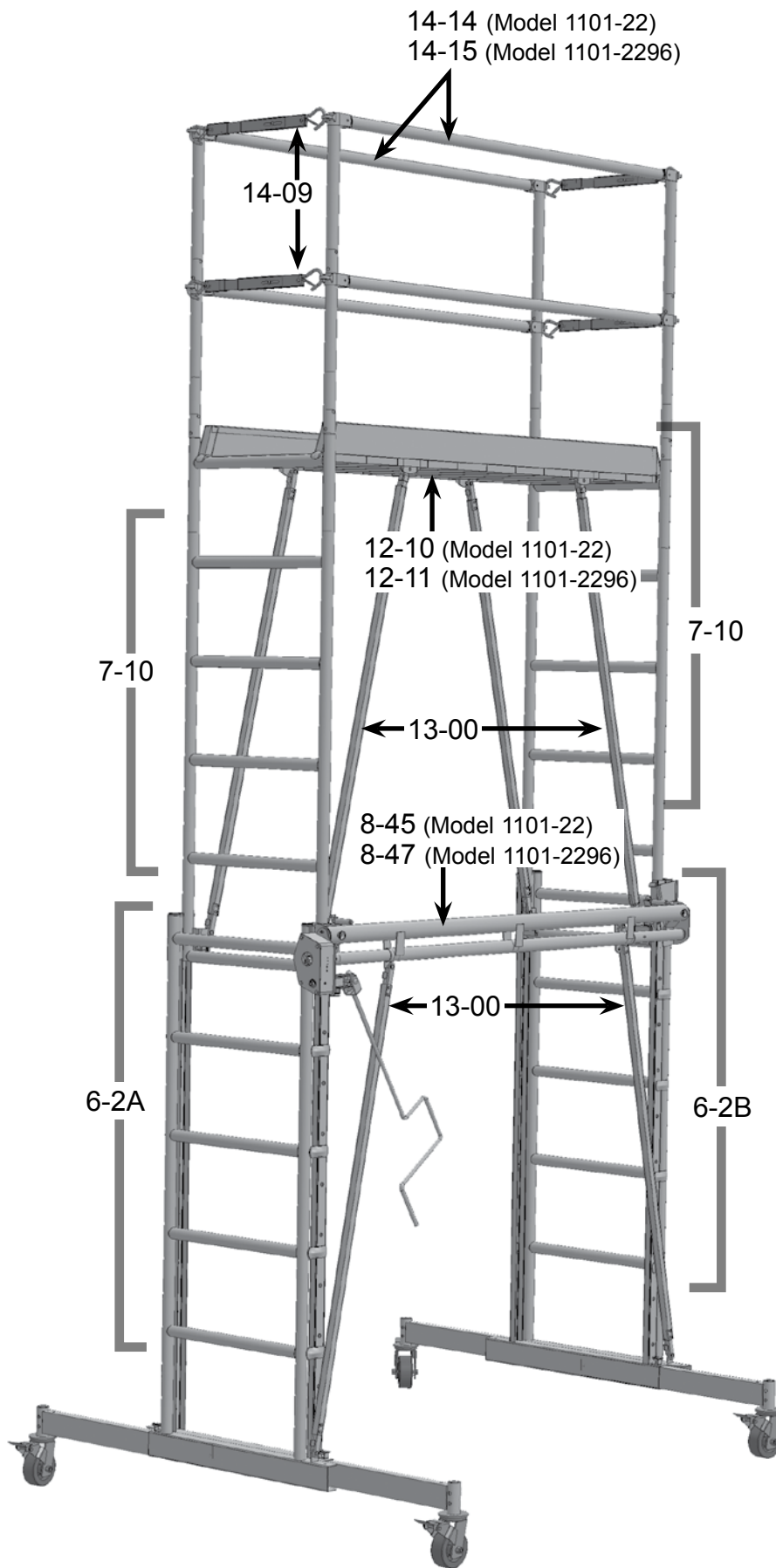

PARTS INDEX Models 1101-22 & 1101-2296

PARTS LIST

Part Description

- 6-01 Latch pin with fasteners (each)
- 6-2A End section "A" (crank side) without removable parts
- 6-2B End section "B" (non-crank) without removable parts
- 7-01 Cable sheave with Axle and Pin
- 7-02 Ladder lock spring pin with fasteners
- 7-10 Complete telescoping ladder section (each) (total of 2)
- 8-02 Winch tube Model 1101-22
- 8-03 Latch Bolt assembly (pair)
- 8-04 Ball bearing (1/2" diameter hole)
- 8-05 Spring socket
- 8-06 Cable spring (compression)
- 8-08 Fiber washer (each) (total of 2)
- 8-13 Nylon washer
- 8-16 Serrated end bushing w/ spring
- 8-17 1/2" washer
- 8-18 1/2" cap nut
- 8-26 30 Tooth Sprocket
- 8-32 Winch tube Model 1101-2296
- 8-36 Inner Hanger Bracket Assembly w/ fasteners
- 8-37 38 Pin #35 Chain w/ fastener
- 8-38 Chain Guard
- 8-39 Outer Hanger Bracket Assembly w/ fasteners
- 8-40 Input Shaft w/ 12 tooth sprocket & fasteners
- 8-41 Crank Handle Assembly
- 8-45 Complete beam assembly for Model 1101-22
- 8-46 Cable Asmbly. 1/8" x 29' 11" with fasteners for Model 1101-22
- 8-47 Complete beam assembly for Model 1101-2296
- 8-48 Cable Asmbly. 1/8" x 31' 8" with fasteners for Model 1101-2296
- 8-49 Beam body with sleeve bearings Model 1101-22
- 8-50 Beam body with sleeve bearings Model 1101-2296
- 9-10 Outrigger with stop bolt (each) (total of 4)
- 10-00 5" Caster, brake mechanism & fasteners (ea.) (total of 4)
- 12-10 Deck for Model 1101-22
- 12-11 Deck for Model 1101-2296
- 13-00 Brace (each) (total of 6)
- 14-14 Model 1101-22 Guard rail w/ chain (each) (total of 4)
- 14-15 Model 1101-2296 Guard rail w/ chain (each) (total of 4)
- 14-09 Safety Chain 23.5"(each) (total of 4)

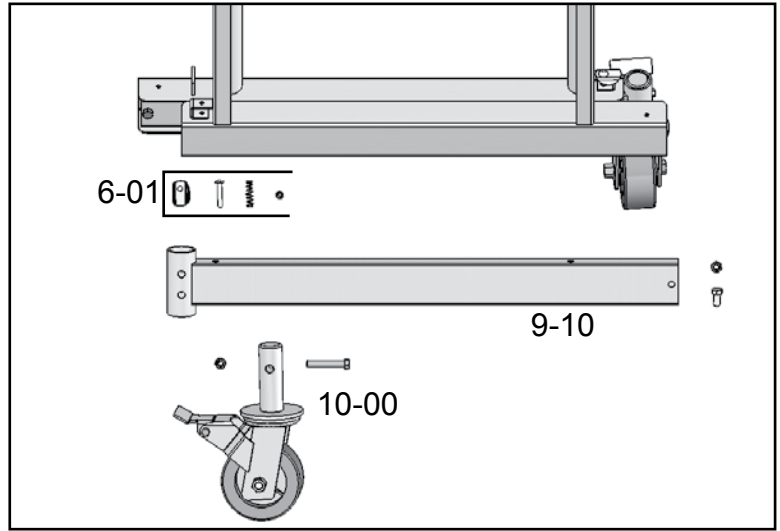

Base End Section Components

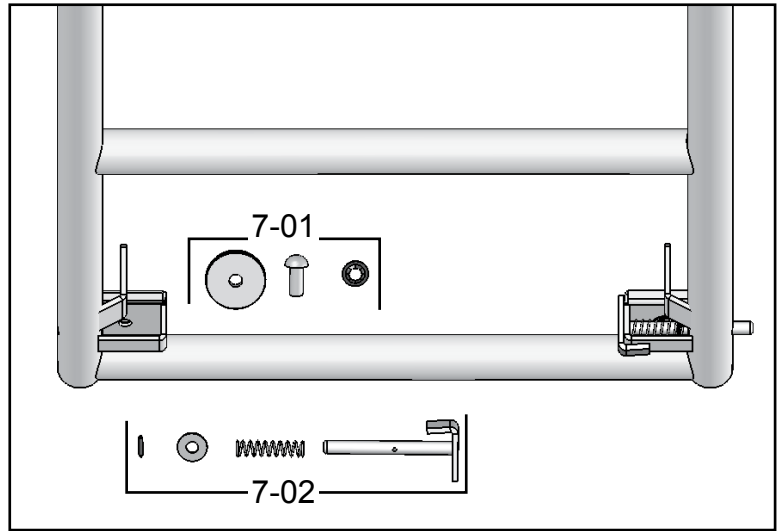

7-10 Complete Telescoping Ladder Section

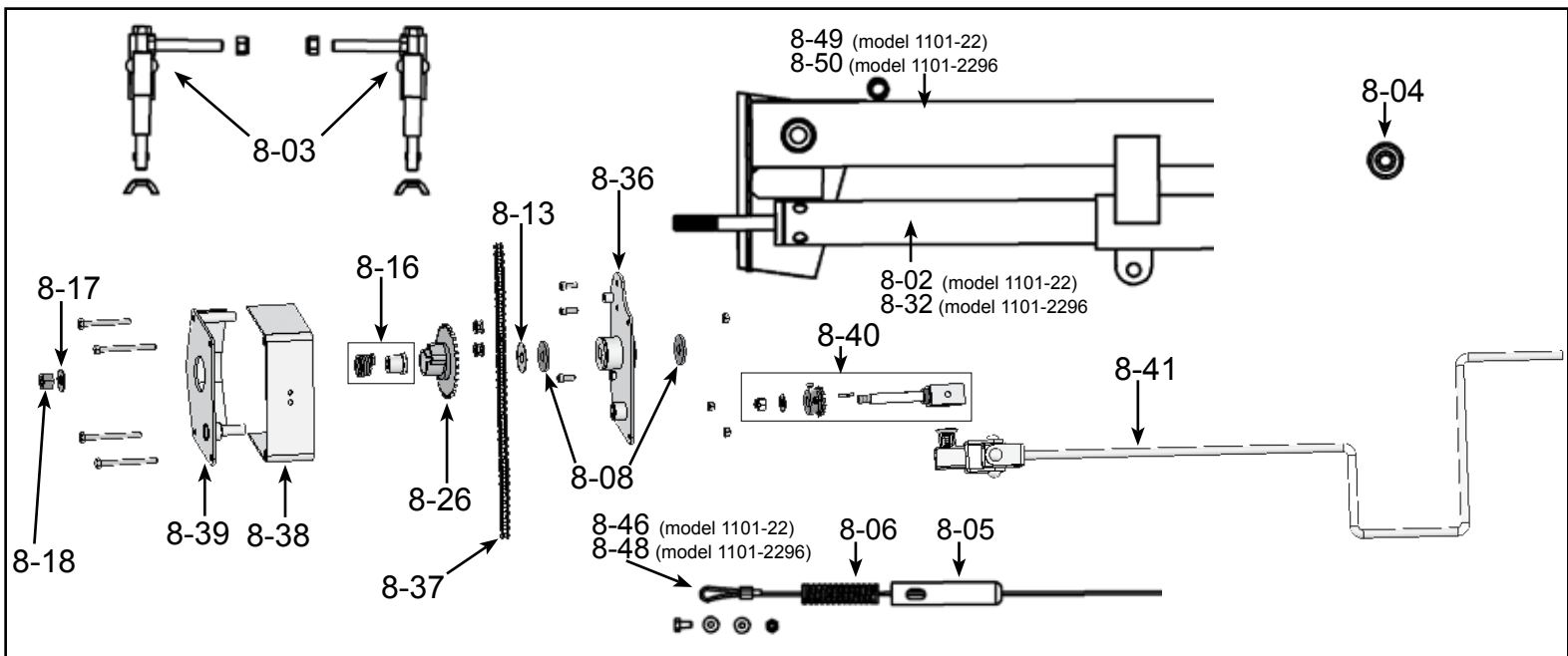

8-45 Complete Beam Assembly (model 1101-22)
8-47 Complete Beam Assembly (model 1101-2296)

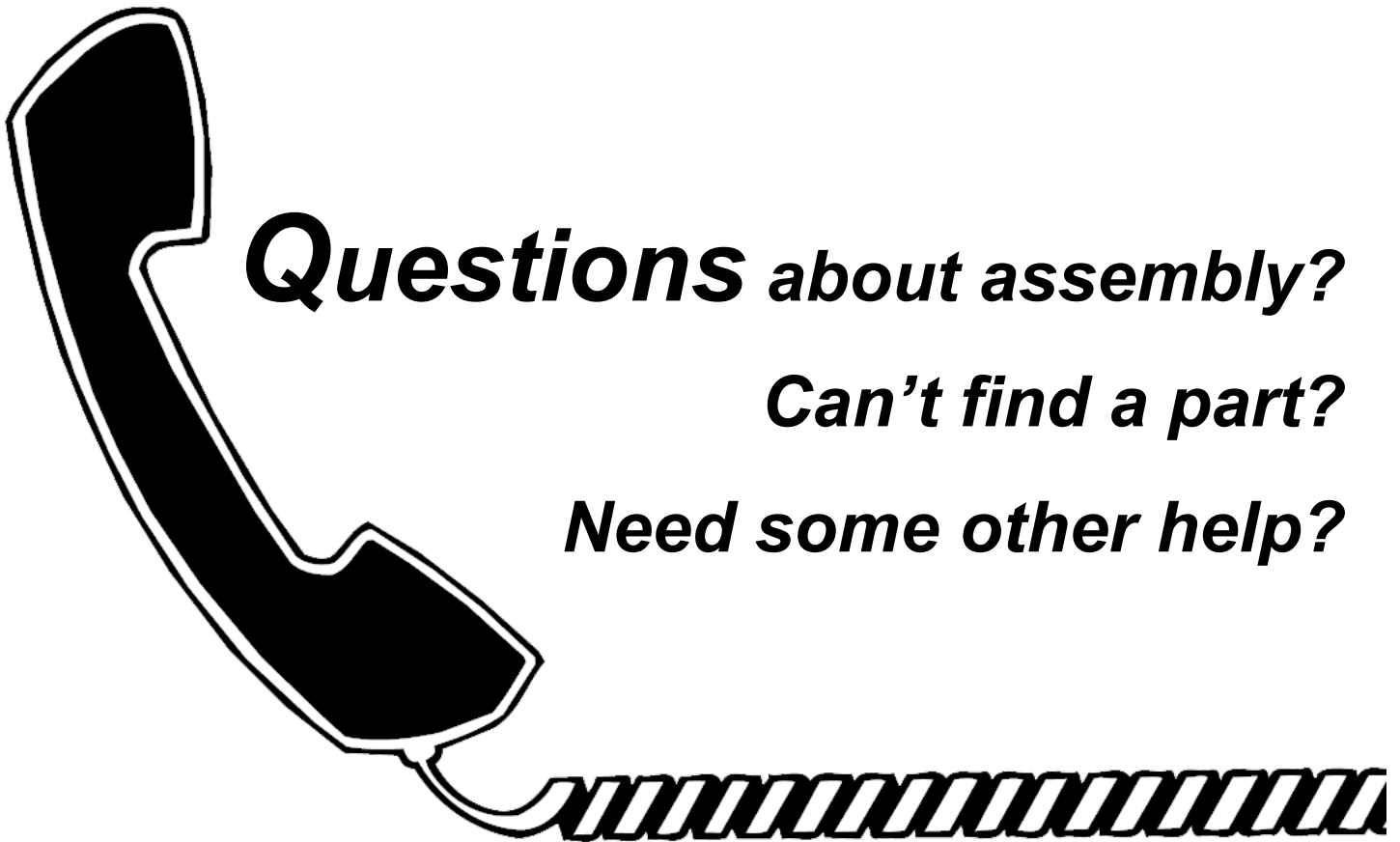

Questions about assembly?

Can't find a part?

Need some other help?

Call us:

1.800.448.0822

We'll get you set up!

Paragon Pro Manufacturing Solutions
7251 S. 42nd St., Grand Forks, ND 58201
701-775-0551 www.telproinc.com