

LP TANK TRUCK- LP-6

APPROX WEIGHT: 557.97 lbs.
 DOES NOT INCLUDE WEIGHT OF POWER OR PACKAGING!!!

*** ANY ADDITIONS, DELETIONS, OR OMISSIONS MUST BE CORRECTED ON THIS DRAWING AS THIS DRAWING WILL BE CONSIDERED ALL INCLUSIVE ***
 ALL GRAPHICS PROVIDED ARE FOR REFERENCE ONLY. IF CERTAIN DIMENSIONS ARE CRITICAL PLEASE VERIFY THOSE DIMENSIONS WITH YOUR SALESPERSON

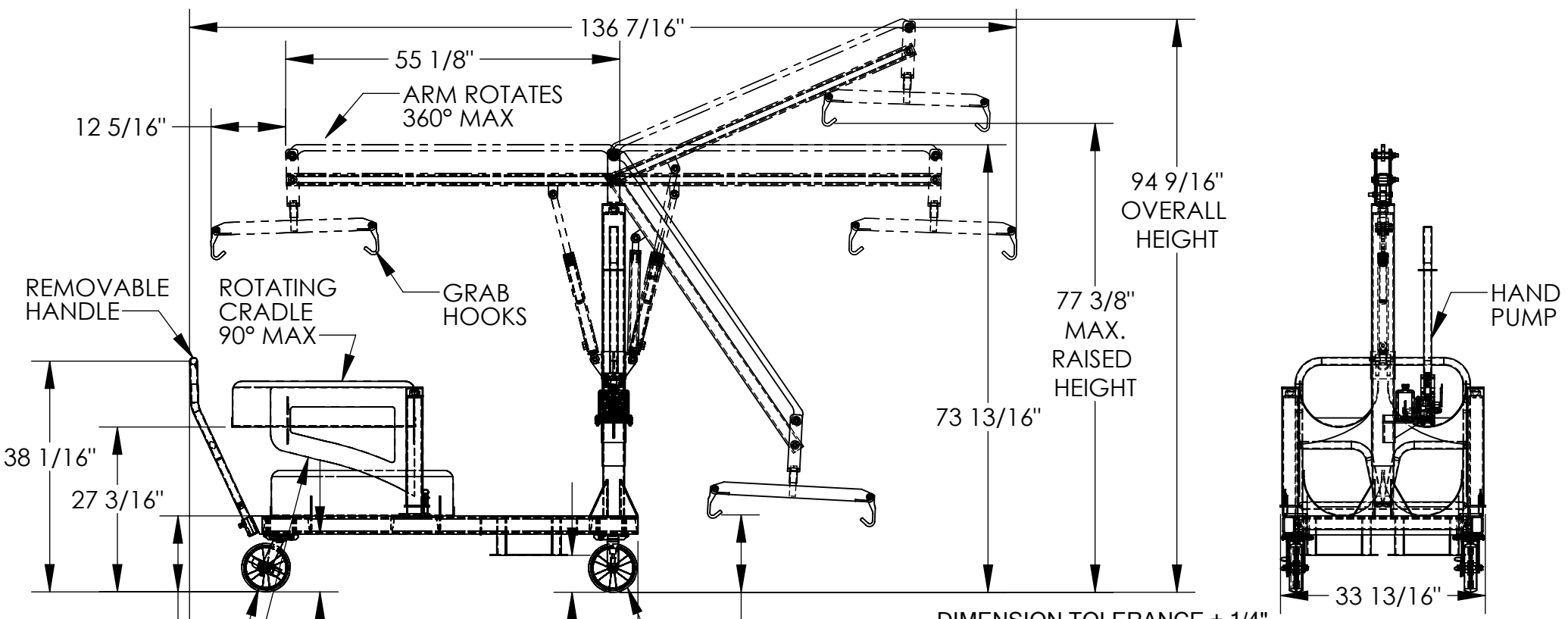

STANDARD FEATURES

- MODEL NUMBER: LP-6
- STORAGE CAPACITY: 6 LP TANKS
- MAXIMUM LIFTING CAPACITY: 65 LBS. IF UNIT IS EMPTY
100 LBS. IF LOWER TANK BAYS ARE FILLED
- MAXIMUM TANK DIAMETER: Ø12 1/2"
- ARM SERVICE RANGE: 12 13/16" TO 77 3/8"
- OVERALL WIDTH: 33 13/16"
- OVERALL LENGTH: 136 7/16"
- OVERALL HEIGHT: 94 9/16"
- GROUND CLEARANCE: 6 1/8"
- HAND PUMP OPERATION
- Ø8" x 2" GLASS FILLED NYLON CASTERS: TWO SWIVEL W/BRAKE, TWO RIGID
- DURABLE LIQUID PAINT BLUE FINISH

SPECIAL FEATURES

NONE

DIMENSION TOLERANCE ± 1/4"

A P P R O V A L

I, THE UNDERSIGNED, AGREE THAT THE PRODUCT AS REPRESENTED SATISFIES DESIGN AND DIMENSION REQUIREMENTS. I ALSO ACKNOWLEDGE MY DUTY TO CONFIRM PRODUCT AND INSTALLATION COMPLIANCE WITH ALL APPLICABLE FEDERAL, STATE AND LOCAL REGULATIONS AND STANDARDS.

UNITS REQUIRING APPROVAL DRAWINGS OR MODIFIED ARE NON-RETURNABLE

As drawn As marked

Signed: _____ Date: _____

Printed Name: _____

LEAD TIME WILL START UPON RECEIPT OF SIGNED APPROVAL DRAWING

DISTRIBUTOR'S NAME:		P.O.#
VESTIL MANUFACTURING		X
DRAWN BY: TAL		W.O.#
DATE: 5/26/2016		X
REFERENCE: X	SCALE: 1:24	SALES: X
QUOTED LEAD TIME: X	QUOTE # X	FILE NAME:
		33-007-146