

HIGH RISE LIFT TRUCK - HIPM-2048-AC

APPROX WEIGHT: 519.78 lbs.
 DOES NOT INCLUDE WEIGHT OF POWER OR PACKAGING!!!

*** ANY ADDITIONS, DELETIONS, OR OMISSIONS MUST BE CORRECTED ON THIS DRAWING AS THIS DRAWING WILL BE CONSIDERED ALL INCLUSIVE ***

ALL GRAPHICS PROVIDED ARE FOR REFERENCE ONLY. IF CERTAIN DIMENSIONS ARE CRITICAL PLEASE VERIFY THOSE DIMENSIONS WITH YOUR SALESPERSON

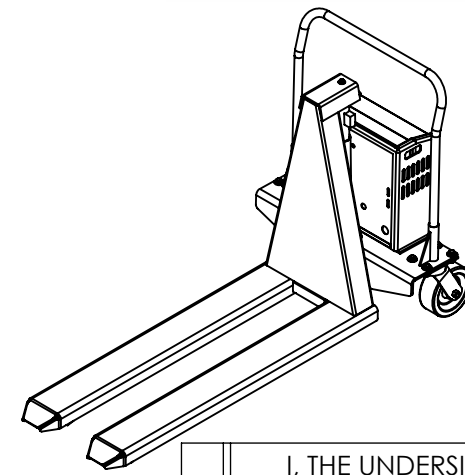
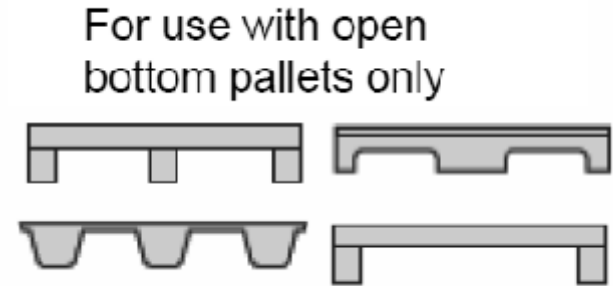
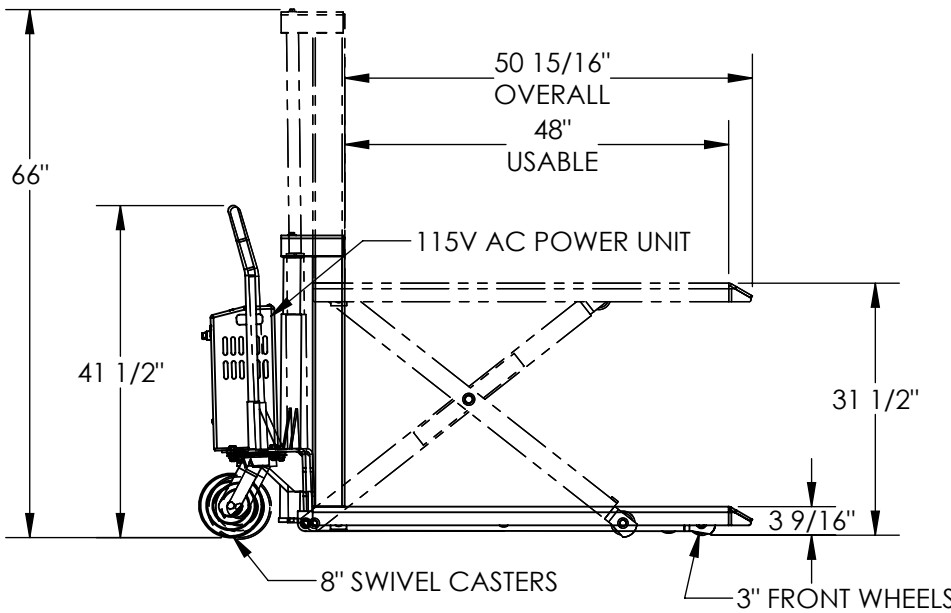
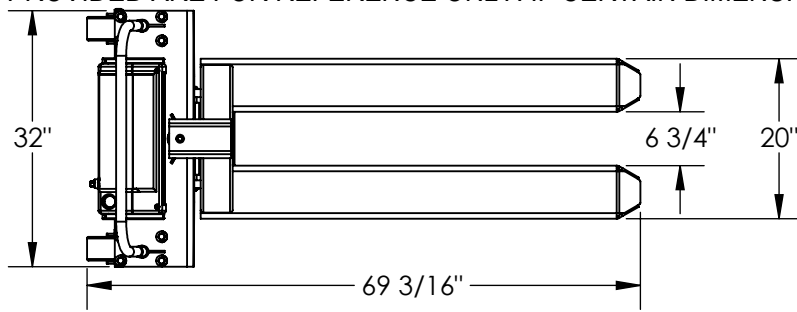

DIMENSION TOLERANCE ± 1/4"

STANDARD FEATURES

- MODEL NUMBER IS HIPM-2048-AC
- OVERALL WIDTH IS 32"
- OVERALL LENGTH IS 69 3/16"
- OVERALL LOWERED HEIGHT IS 41 1/2"
- OVERALL RAISED HEIGHT IS 66"
- FORK WIDTH IS 20"
- USABLE FORK LENGTH IS 48"
- LOWERED FORK HEIGHT IS 3 9/16"
- RAISED FORK HEIGHT IS 31 1/2"
- MAX CAPACITY IS 2500 LBS
- FOR USE WITH OPEN BOTTOM SKIDS ONLY
- POWER SPECIFICATIONS: AC 115V WITH HAND HELD PENDANT CONTROL
- Ø 8" x 3" PHENOLIC REAR SWIVEL CASTERS
- DUAL Ø3" PHENOLIC FRONT WHEELS
- DURABLE LIQUID PAINT BLUE FINISH

SPECIAL FEATURES

NONE

UNITS REQUIRING APPROVAL DRAWINGS OR MODIFIED ARE NON-RETURNABLE

[] As drawn [] As marked

Signed: _____ Date: _____

Printed Name: _____

LEAD TIME WILL START UPON RECEIPT OF SIGNED APPROVAL DRAWING

DISTRIBUTOR'S NAME:		P.O.#
VESTIL MANUFACTURING		X
		W.O.#
DRAWN BY: KGH		X
DATE: 7/27/2016		SALES: X
REFERENCE: X	SCALE: 1:24	FILE NAME:
QUOTED LEAD TIME: X	QUOTE # X	15-007-033-002