

VESTIL MANUFACTURING CORP.
 2999 N. Wayne St., Angola, IN 46703
 Ph: 260-665-7586 · Fax: 260-665-1339
 E-mail: sales@vestil.com · www.vestil.com

OWNER'S MANUAL

MODEL S-FORK HOISTING HOOK

Serial number _____

| | | | |
|---|---|------------------------------------|---|
| Routine Maintenance & Safety Checks | 2 | Safety & Warning Information | 4 |
| Exploded Parts Drawing & BOM | 2 | Warranty | 4 |
| Operation Instructions | 3 | | |

WARNINGS AND SAFETY INSTRUCTIONS

Ensure that all employees understand and follow the following.

- Read and understand all sections of the owner's manual before using or servicing the hoisting hook.
- Ensure that all information, safety, and warning markings remain legible.
- Do not use the hoisting hook if any damage is observed.
- Always watch the load and the load hook carefully when the hoisting hook is in operation.
- The lifting rigging must be fully retained within the hook's safety latch before lifting any load off the ground.
- Make certain that the load is properly slung and balanced under the hook before lifting with the hoisting hook.
- Do not perform modifications to any part of the hoisting hook. Doing so could cause failure, and will void the warranty.
- Maintenance and repairs are to be done only by personnel qualified to perform the required work.
- Do not use the hoisting hook to pull loads horizontally.
- Always secure the hoisting hook to the fork truck mast with the safety securing strap before connecting a load.
- Consult the fork truck's manufacturer for ratings prior to using.

REPLACEMENT PARTS:

We take pride in using quality parts on the equipment we manufacture. We are not responsible for equipment problems resulting from the use of unapproved replacement parts.

To order replacement or spare parts for this equipment, contact the factory.

In any communication with the factory please be prepared to provide the machine's serial number, which is indicated on the machine dataplate.

RECEIVING INSTRUCTIONS

Every unit is thoroughly tested and inspected prior to shipment. However, it is possible that the unit could incur damage during transit.

Inspect the unit closely when it arrives. *If you see evidence of damage or rough handling to either the packaging or to the product when it is being unloaded, **immediately** make a note of it on the Bill Of Lading!*

It is important that you remove the product's packaging upon its arrival to ensure that there is no concealed damage or to enable a timely claim with the carrier for freight damage.

Also verify that the product and its specifications are as ordered.

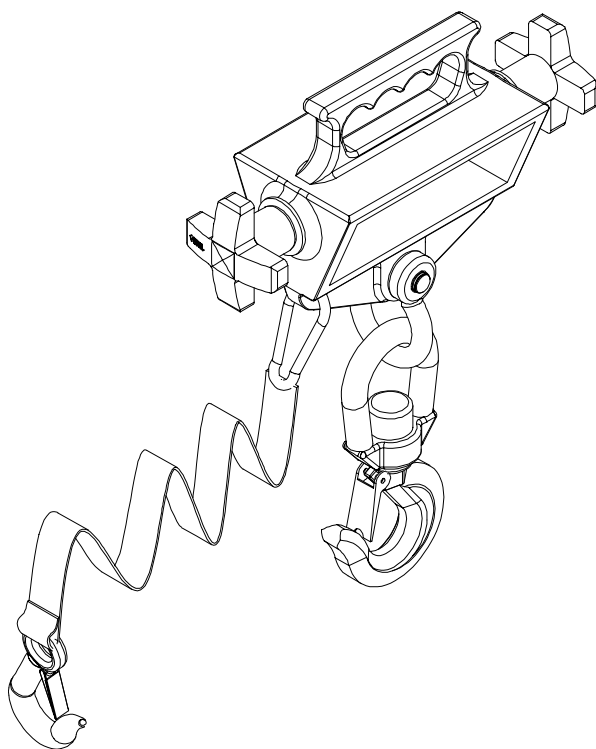

ROUTINE MAINTENANCE & SAFETY CHECKS – S-FORK
MODELS -SL (W/ SWIVEL HOOK) AND -RL (RIGID HOOK)

- (A) Before each use inspect for the following:
- 1.) Visible damage to the casting, the lifting hook, or the clevis.
 - 2.) Proper operation of the load hook's safety latch.
 - 3.) Excessive play in the load hook swivel (-SL models only).
 - 4.) The fork securing screws and the clevis bolt screw in easily.
 - 5.) Apparent damage or fatigue to the safety strap (used to secure the S-FORK to the fork truck mast), or to the safety latch at the end of the strap.
- (B) Closely inspect each month for:
- 1.) Structural damage, deformation, or cracks to the body of the S-FORK.
 - 2.) Signs of fatigue, cracks, or deformation to the clevis, the clevis attachment point, or the load hook.
 - 3.) Proper operation of, and no damage to, the safety latch on the load hook.
 - 4.) Excessive wear or damage to the fork securing screws.
 - 5.) Excessive wear or deformation of the clevis or clevis bolt., .
 - 6.) Signs of excessive wear or damage to any part of the safety strap, including the strap hook's safety latch.
 - 7.) Legibility of all the information, safety, and warning markings.
- (C) Yearly inspection
 If possible, load the S-FORK to full rated capacity. Carefully observe the hook (and swivel on -SL models) for looseness and for deflection of any of the hoisting hook's parts. After the load is removed, closely inspect all parts and surfaces for fatigue or deformation.

EXPLODED PARTS VIEW AND BILL OF MATERIALS -- S-FORK

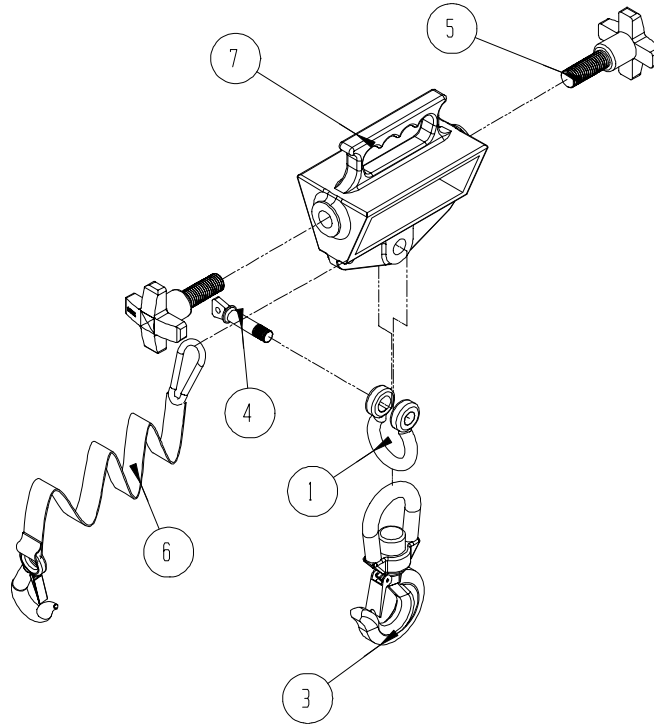

| Item: | Qty. | Part number | Description |
|-------|------|----------------|--------------------------------------|
| 1 | 1 | 08-145-003-001 | Clevis (2-ton) |
| 3 | 1 | 08-145-001 | Lifting hook w/ safety latch (2-ton) |
| 4 | 1 | 08-145-003-A | Screw, clevis |
| 5A | 1 | 08-025-004 | Screw, fork securing, 3/4" x 2" lg |
| 5B | 1 | 08-025-008 | Screw, fork securing, 3/4" x 4" lg |
| 6 | 1 | 08-145-027 | Securing strap w/ safety latch |
| 7 | 1 | 08-028-098 | Casting |

OPERATION INSTRUCTIONS – S-FORK

- ⚡ *Ensure that all employees involved in the operation and maintenance of this hoisting hook understand and follow these instructions!*

The S-FORK fork-mounted hoisting hook is intended to be used to lift and transport stable, hanging loads, up to its rated capacity, from a properly-rated fork truck's fork. The rating of the required fork truck, and the position of the hoisting hook on the fork truck's fork, will depend on the center of gravity of the load and the height to which the load will need to be lifted. Consult the fork truck manufacturer for a fork truck's rating.

Note: OSHA 29CFR, Chapter XVII, Part 1910.178 (a)(4) states, "Modifications and additions which affect capacity and safe operation (of a fork truck) shall not be performed by the customer or user without manufacturer's prior written approval. Capacity, operation, and maintenance instruction plates, tags, or decals shall be changed accordingly. And 1910.178 (a)(5) states that "If (a fork) truck is equipped with front-end attachments other than factory installed attachments, the user shall request that the truck be marked to identify the attachments and show the approximate weight of the truck and attachment combination at maximum elevation with load laterally centered."

Attaching the S-FORK to a fork truck:

Slide the hoisting hook onto the fork truck's fork to the desired point and turn the securing screw on each side clockwise until they are both tight against the side of the fork. There should be approximately the same number of screw threads turned in on each side of the hoisting hook. Secure the hoisting hook to the fork truck's mast by wrapping the hoisting hook's securing strap around a vertical member of the fork carriage and fasten the strap's snap hook back onto the strap.

Loading:

The load rating, in pounds and kilograms, is shown on the top of the hoisting hook. It indicates the static capacity of the hoisting hook.

- ⚡ *Warning:* Do not attempt to use the hoisting hook in any pulling application.
- ⚡ *Warning:* Do not exceed the hoisting hook's load rating. Permanent damage to the hoisting hook or injury to personnel could result from exceeding the listed capacity.
- ⚡ *Warning:* Caution must be exercised when determining the best method by which to hang a load from the hoisting hook. Swinging suspended loads can injure personnel and damage equipment.
- ⚡ *Caution:* Consult the fork truck owner's manual for the forklift's capacity at the intended vertical and horizontal center-of-gravity of the load.

Operation:

Before using the hoisting hook, review all of the sections included in this manual!

- *Consult ANSI / ASME B56.1-2000, "Safety Standard For Low Lift And High Lift Fork Trucks," for further information regarding procedures to be used when operating a fork truck with a hoisting hook attached.*
- ⚡ *Warning:* Do not attempt to use the hoisting hook without the fork securing screws being tightened and the safety strap securely attached to the fork truck's mast. The strap hook's safety latch must be closed around the strap.

Tilt the fork truck's mast back before attaching a load to the hoisting hook.

Use an appropriate lifting chain, nylon strap, or choker to connect the load to the hoisting hook.

Alert personnel in the area to stand at a safe distance from the load before attempting to lift or lower a load.

Lift the load slowly.

Watch the rigging and the load carefully for slippage or uneven lifting. If necessary, lower the load and adjust the rigging to ensure the load will remain stable while hanging from the hoisting hook.

Keep loads as close to the ground as possible and do not exceed a travel rate of two feet/second when loads are being transported. Accelerate and decelerate slowly to minimize load swing.

Avoid bumps, potholes, and inclined surfaces when transporting a load.

When loads are lowered into place, be certain that the load is stable and well-supported before attempting to remove the rigging.

- ⚡ *Warning:* Improper rigging practices could result in injury to personnel or damage to property. Use only properly-rated lifting chains, nylon straps, chokers, and connecting hardware when lifting loads.
- ⚡ *Warning:* All personnel must maintain a safe distance from loads whenever they are suspended from the hoisting hook. Be certain no part of any person or object is under or near any part of the load.
- ⚡ *Caution:* Use the hoisting hook only on a smooth, level, finished surface. Avoid sudden stops or quick turns.
- ⚡ *Caution:* Always carefully watch the hook and any load hanging from it when it is in use.
- ⚡ *Caution:* Never use the hoisting hook if any damage is observed or if it is in need of repairs. Notify your supervisor or maintenance personnel if you notice anything out of the ordinary.

Ensure that all information, safety, and warning markings are legible.

SAFETY & WARNING LABELING

Ensure that all information, safety, and warning markings are legible.

The following text is located on the top of the S-HOOK next to the handle.

⚠ *Warning:* Do not use the hoisting hook if this text is not legible!

MODEL S-FORK
UP TO 3,000LB (1361 KGS) STATIC HOOK CAPACITY
TIGHTEN UNIT TO FORK WITH LOCKING KNOBS. UNIT MUST
BE ATTACHED WITH CHAIN TO MAST BEFORE USE.

PRODUCT WARRANTY

90-DAY LIMITED WARRANTY

The manufacturer warrants for the original purchaser against defects in materials and workmanship under normal use one 90 days after the date of shipment. Any part that is determined by the manufacturer to be defective in material or workmanship and returned to the factory, shipping costs prepaid, will be, as the exclusive remedy, repaired or replaced at our option. Labor costs for warranty repairs and/or modifications are not covered unless done at manufacturer's facilities or pre-approved in advance by the manufacturer. Any modifications performed without written approval of the manufacturer may void warranty. This limited warranty gives purchaser specific legal rights which vary from state to state.

All specifications are subject to change without notice.

LIMITATION OF LIABILITY

To the extent allowable under applicable law, the manufacturer's liability for consequential and incidental damages is expressly disclaimed. The manufacturer's liability in any event is limited to, and shall not exceed, the purchase price paid. Misuse or modification may void warranty.

Warranty does not cover labor or consequential damages including, but not limited to, business interruption costs, lost profits, or lost business opportunities.

WARRANTY DISCLAIMER

The manufacturer has made a diligent effort to accurately illustrate and describe their products. However, such illustrations and descriptions are for the sole purpose of identification, and do not express or imply a warranty that the products are merchantable or fit for a particular purpose, or that the products will necessarily conform to the illustrations or descriptions.

The provisions of the warranty shall be construed and enforced in accordance with the Uniform Commercial Code and laws as enacted in the State of Indiana.

DISPOSITION

Our company will make a good faith effort for prompt correction or other adjustment with respect to any product that proves to be defective within the Limited Warranty Period. Warranty claims must be made within the stated warranty period.