

Ergonomic Solutions

OWNER'S MANUAL

**STEEL GANTRY CRANES • MODEL AHS, FHS
 ALUMINUM GANTRY CRANES • MODEL AHA**

Contents	
Safety Precautions	1
Receiving Instructions	1
Warranty	1
Assembly Instructions	2
Height Adjustment	3
Inspection Instructions	4
Testing Instructions	5
Parts List/Drawing (AHS series)	6
Parts List/Drawing (AHA series)	7
Warning Label Identification	8

SAFETY PRECAUTIONS

Read owner's manual completely before operating unit!

- Never exceed the maximum load capacity printed on the top beam. The capacity includes the weight of hoist and trolley.
- Check for damage and be sure all hardware is tight before each use.
- Never move or load the gantry unless both height adjustment pins are fully inserted.
- Lock all wheels perpendicular to each other before loading.
- Stand clear of hanging loads.
- Never cantilever loads off of one end of the gantry.
- When moving a load, be sure the load center is as low to the ground as possible. If not lowered, tipping can occur.
- Never attempt to adjust the gantry beam height while a load is attached.
- When moving is not required, always lock the casters perpendicular to each other.
- Keep clear of electrical wires and all electrical equipment.
- Make sure all operator safety labels are in place and legible.

RECEIVING INSTRUCTIONS

Every unit is thoroughly inspected prior to shipment. However, it is possible that the unit may incur damage during transit. If damage is noticed when unloading, make a note of it on the **BILL OF LADING**. Remove all packing and strapping material, then inspect the unit again for damage. **IF DAMAGE IS EVIDENT, FILE A CLAIM WITH THE CARRIER IMMEDIATELY!**

WARRANTY

This product is warranted for 90 DAYS from date of purchase to be free of manufacturing defects in material and workmanship. The manufacturer's obligation hereunder is limited to repairing such products during the warranty period, provided the product is sent prepaid back to the factory.

This warranty does not cover normal wear of parts or damage resulting from any of the following: negligent use or misuse of the product, use or application contrary to installation instructions, or disassembly, repair or alteration by any person prior to authorization from a factory representative.

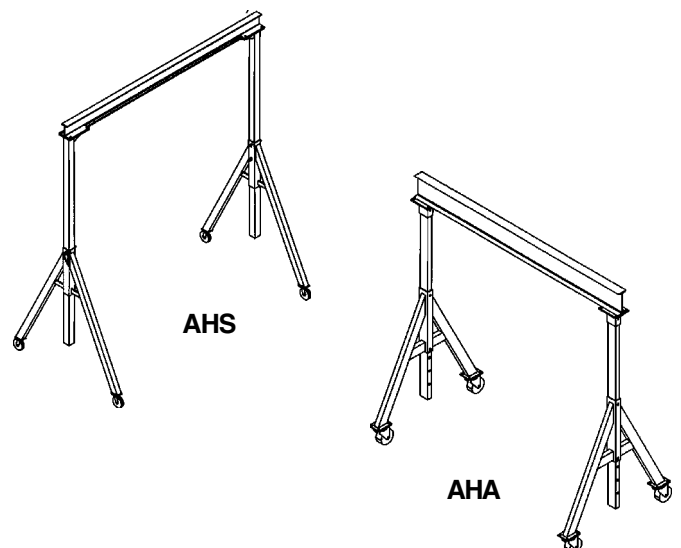

**STEEL & ALUMINUM GANTRY CRANES
 AHS & AHA SERIES**

ENGLISH

ESPAÑOL

FRANÇAIS

ASSEMBLY INSTRUCTIONS

- The model FHS fixed-height steel gantry crane and the AHS and AHA adjustable-height steel and aluminum gantry cranes are suitable for use indoors and outdoors for many industrial and commercial applications.
- Modifications or additions to the gantry crane without prior authorization from the manufacturer may void the crane's warranty.
- Assembly must be performed by suitably trained personnel with access to the appropriate equipment.

For assembly you will need the following:

1. A fork truck or overhead hoist or crane.
2. Basic fastener tightening hand tools such as a wrench set or a socket set, an adjustable wrench, ect.

Installing the crane's top beam and leg assemblies together:

1. On adjustable-height models, (AHS and AHA), insert the upper frame sides into the lower frame sides and secure both sides at the same level with the height adjustment pins and clips.
2. Lay out the crane's top beams and the two leg assemblies on a floor area that has ample clear working space.
3. Attach the beam clamps (or clamp plates, on lighter capacities) to the top flanges on both leg assemblies using the 1/2"-13 structural bolts and nuts provided, as shown in the illustration.
4. Slide the bottom flange of each end of the I-beam between the beam clamps (or clamp plates) and the leg assemblies' top flange until the desired usable beam length is attained.
5. Tighten all the beam clamp units to a torque of 50-52 foot-pounds.
6. Tip the assembly upright into a standing position using a fork truck or overhead crane.
7. Lifting at the center of the cross beam, slowly raise the assembled gantry just high enough to install the casters.

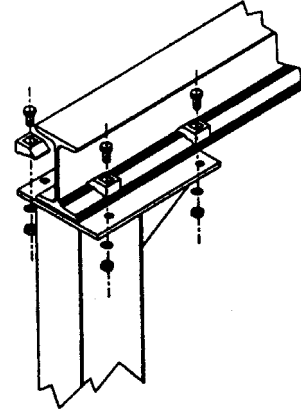

Installing the casters to each leg:

8. Hold an 8" caster under the bottom flange of each leg of the crane so that the caster rig's holes match the holes in the leg's bottom flange.
9. Hang a caster from the bottom of each leg, installing one bolt at a corner of each rig that is nearer the center of the leg set. Washers and nuts, as shown in the illustration, are not used on the 2,000 & 4,000 lb. capacity steel gantrys, which have 5/16"-18 tapped mounting holes.
10. Insert the detent assembly under the caster rig, as shown, and install the remaining three fasteners.
11. Tighten the locking nuts securely.
12. Rotate the wheels so that all are parallel with each other, then lock them in place with the detents.
13. Slowly lower the completed gantry crane so that it rests on the casters.

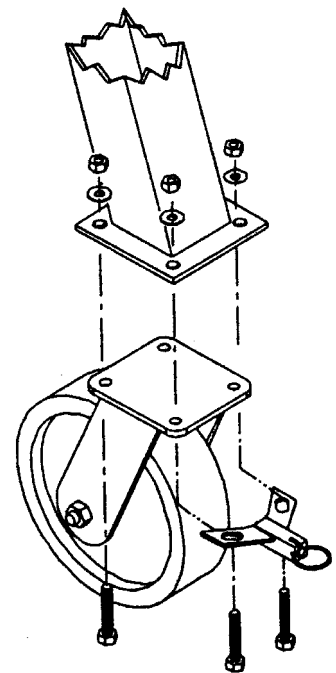

HEIGHT ADJUSTMENT

For adjustable height models, the height of the top beam can be adjusted by the following ways:
Never attempt to adjust while loaded.

A.) Using a forklift or an overhead crane

- 1.) Lock all the casters in perpendicular position to one another.
- 2.) A forklift or an overhead crane is used to support the top beam.
- 3.) Release the pin clips from the height adjustment pins on both sides of the frame, and pull out the pins.
- 4.) The top beam can now be lowered or raised to the desired height with the help of the forklift or overhead crane.
- 5.) Insert the height adjustment pins and secure them with the pin clips.

B.) Using the ratchet cable puller (*customer supplied*)

- 1.) Lock all the casters in perpendicular position to one another.
- 2.) Attach one end (hook) of the ratchet cable puller to the bracket (position A) on the leg assembly, and the other end to the end of the side frame (position B). **Please refer to figure below: Figure 3**
- 3.) Tighten the cable to hold the side frame in place.
- 4.) Release the pin clip from the height adjustment pin, and pull out the pin.
- 5.) The top beam can now be lowered or raised to the desired height by extending the cable, or shortening the cable.
- 6.) Insert the height adjustment pin and secure it with the pin clip.
- 7.) Repeat the above procedures for the other side.

CAUTION: NEVER STAND BELOW THE TOP BEAM WHILE TRYING TO ADJUST THE HEIGHT !

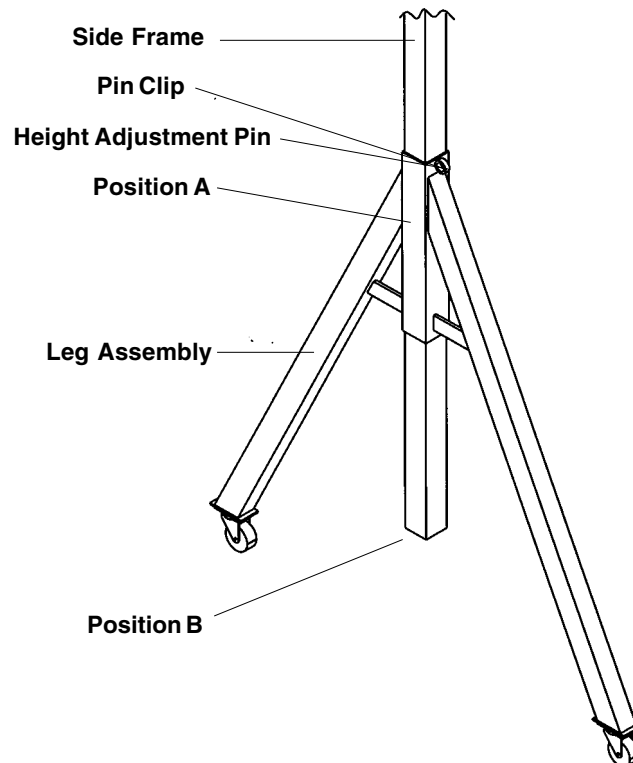
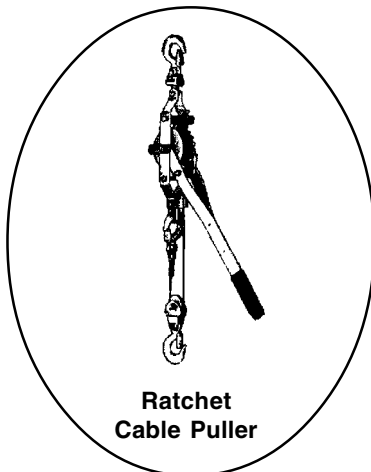
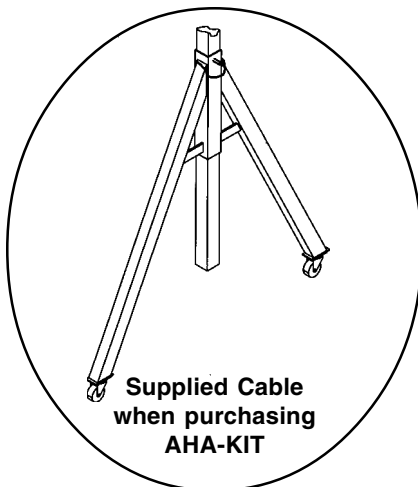

Figure 3

INSPECTION INSTRUCTIONS

Per OSHA Regulations **1910.179** and American Society of Mechanical Engineers (A.S.M.E.) **B30.17 "Overhead and Gantry Cranes."**, all gantry cranes should have an:

1910.179(j)(1)(i) Initial inspection - Prior to initial use all new and altered cranes shall be inspected to insure compliance.

Besides that, for gantry cranes in regular service, there are two general classifications of inspections based upon the intervals at which the inspection should be performed. The intervals in turn are dependent upon the nature of the critical components of the crane and the degree of their exposure to wear, deterioration, or malfunction. The two general classifications are herein designated as "frequent" and "periodic" with respective intervals between inspections as defined below:

1910.179(j)(1)(ii)(a) Frequent inspection - Daily to monthly intervals.

1910.179(j)(1)(ii)(b) Periodic inspection - 1 to 12 month intervals.

1910.179(j)(2) Frequent Inspection

The following items shall be inspected for defects at intervals as defined above or as specifically indicated, including observation during operation for any defects which might appear between regular inspections. All deficiencies such as listed shall be carefully examined and determination made as to whether they constitute a safety hazard:

- All functional operating mechanisms for maladjustment interfering with proper operation. Daily.
- Hooks with deformation or cracks. Visual inspection daily; monthly inspection with a certification record which includes the date of inspection, the signature of the person who performed the inspection and the serial number, or other identifier, of the hook inspected.
- Hoist chains, including end connections, for excessive wear, twist, distorted links interfering with proper function, or stretch beyond manufacturer's recommendations. Visual inspection daily; monthly inspection with a certification record which includes the date of inspection, the signature of the person who performed the inspection and an identifier of the chain which was inspected.
- All functional operating mechanisms for excessive wear of components.
- Rope reeving for noncompliance with manufacturer's recommendation.

1910.179(j)(3) Periodic Inspection

Complete inspections of the crane shall be performed at intervals as generally defined above, depending upon its activity, severity of service, and environment, or as specifically indicated below. These inspections shall include the requirements of the frequent inspection stated above and in addition, the following items. All deficiencies such as listed shall be carefully examined and determination made as to whether they constitute a safety hazard:

- Deformed, cracked, or corroded members.
- Loose bolts or fasteners.
- Cracked or worn hoist.
- Worn, cracked or distorted parts such as pins, bearings, shafts, gears, rollers, locking and clamping devices.
- Load, wind, and other indicators over their full range, for any significant inaccuracies.
- Gasoline, diesel, electric, or other powerplants for improper performance or noncompliance with applicable safety requirements. (IF APPLICABLE)
- Excessive wear of chain drive sprockets and excessive chain stretch.

TESTING INSTRUCTIONS

OSHA also requires two classifications of testing to be performed [per OSHA Regulations **1910.179(k)**]. These two testings are:

1910.179(k)(1) Operational tests

1910.179(k)(2) Rated load test

1910.179(k)(1) Operational Tests

- (i) Prior to initial use all new and altered cranes shall be tested to insure compliance with this section including the following functions:
 - (a) Hoisting and lowering.
 - (b) Trolley travel.
 - (c) Bridge travel.
 - (d) Limit switches, locking and safety devices.
- (ii) The trip setting of hoist limit switches shall be determined by tests with an empty hook traveling in increasing speeds up to the maximum speed. The actuating mechanism of the limit switch shall be located so that it will trip the switch, under all conditions, in sufficient time to prevent contact of the hook or hook block with any part of the trolley.

1910.179(k)(2) Rated Load Test

Test loads shall not be more than 125 percent of the rated load unless otherwise recommended by the manufacturer. The test reports shall be placed on file where readily available to appointed personnel.

**REFER TO OSHA'S STANDARD 1910.179 FOR COMPLETE INFORMATION ON
OVERHEAD & GANTRY CRANE DEFINITIONS, GENERAL REQUIREMENTS,
HOISTING EQUIPMENT, MAINTENANCE, ROPE INSPECTION,
HANDLING OF THE LOAD, AND
OTHER REQUIREMENTS.**

For OSHA publications, including informational materials
on standards and regulations, please contact:

OSHA's Publications Office
200 Constitution Avenue, N.W., Room N3101
Washington, DC 20210
Ph.: (202)219-4667 Fax: (202)219-9266

**ALSO REFER TO AMERICAN SOCIETY OF MECHANICAL ENGINEERS (A.S.M.E.)
B30.17 "OVERHEAD & GANTRY CRANES."**

For copies of A.S.M.E. B30.17
please contact:

American Society of Mechanical Engineers
Order Department 1-800-THE-ASME

AHS SERIES STEEL GANTRY CRANES

Capacity 2,000 lbs. and 4,000 lbs.

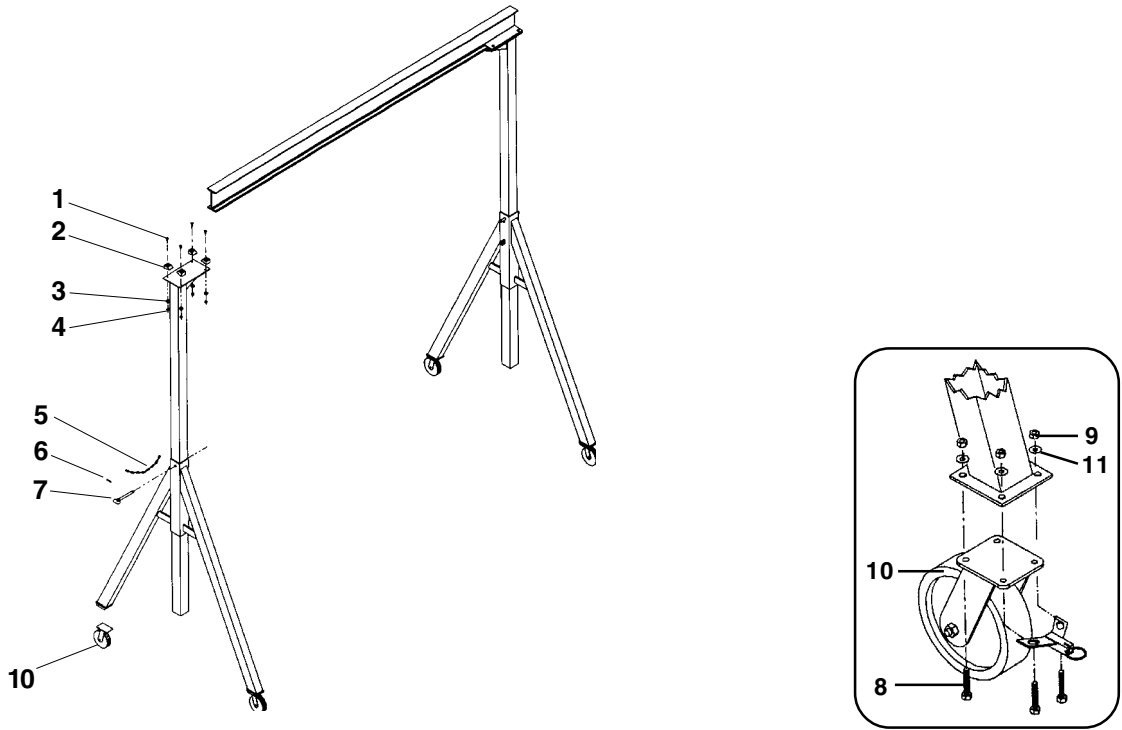

PARTS IDENTIFICATION AHS SERIES STEEL GANTRY CRANES

ITEM NO.	DESCRIPTION	ENGINEER NO.	QTY.
1	Bolt, 1/2"-13 x 2" UNC	A/L	8
2	Clamp Beam	28-145-002	8
3	Washer, Lock 1/2"	A/L	8
4	Nut, 1/2"-13	A/L	24
5	Chain, 3/16" dia. x 16" long	08-145-011	2
6	Clip, Hitch Pin, # 8	A/L	2
7	Pin, 1" dia. x 5-3/4" overall (4-1/2" useable)	08-112-002	2
8	Bolt 5/16"-18 UNC x 3/4" long (2-4K)	A/L	16
	Bolt, 1/2"-13 UNC x 1-1/2" long (6-8K)	A/L	16
9	Washer, Lock, 5/16"	A/L	16
10	Wheel, Caster, 8" x 2" Phenolic with Lock (2-4K)	16-132-063	4
	Wheel, Caster, 8" x 3" Phenolic with Lock (6-8K)	16-132-064	4
11	Washer, 5/16" (2-4K)	A/L	16
	Washer, 1/2" (6-8K)	A/L	16
12	Locking Mechanism, 4-Position (2-4K)	28-037-002	4
	Locking Mechanism, 4-Position (6-8K)	28-037-003	4

a/k Available only with purchase of kit

AHA SERIES ALUMINUM GANTRY CRANES

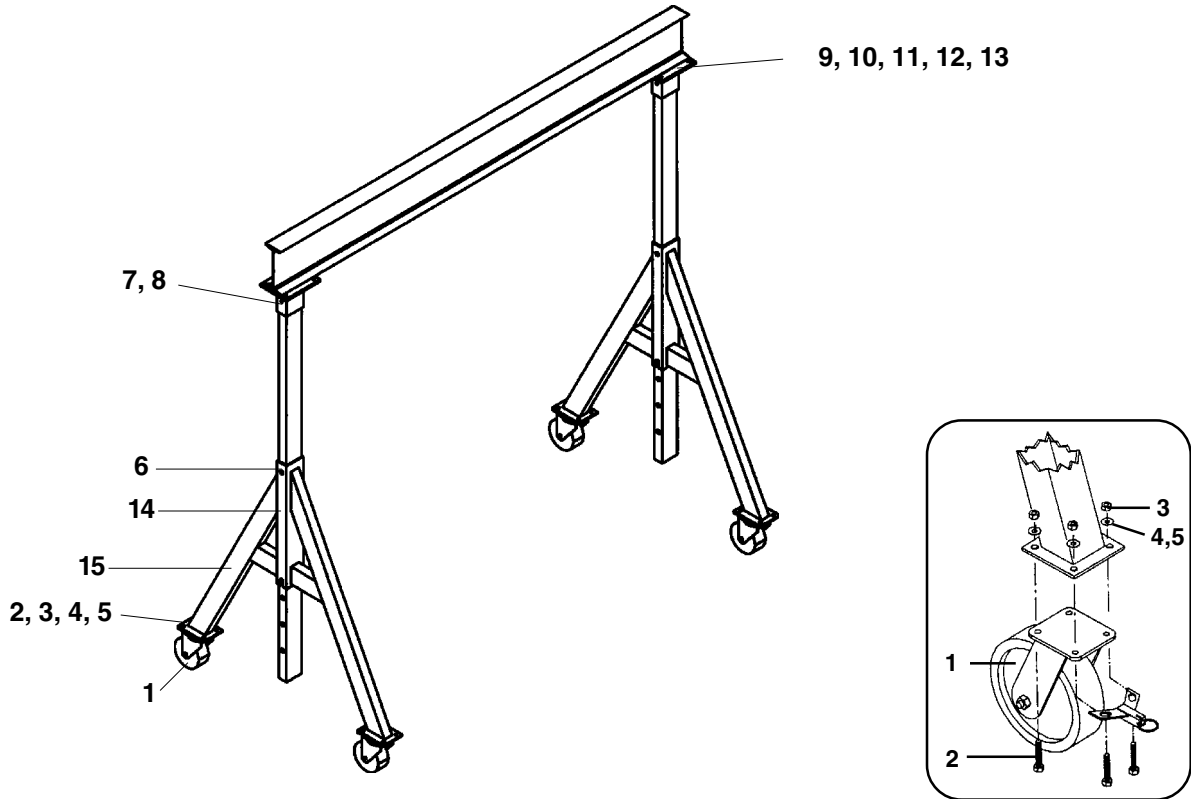

PARTS IDENTIFICATION AHA SERIES ALUMINUM GANTRY CRANES

ITEM NO.	DESCRIPTION	ENGINEER NO.	QTY.
1	Wheel, Caster, 8" x 2" Phenolic with Lock	16-132-063-B	4
2	Bolt, 3/8"-16 UNC x 1-1/4 Long	A/L	16
3	Nut, 3/8"-16 UNC	A/L	16
4	Washer, Flat, 3/8"	A/L	16
5	Washer, Lock, 3/8"	A/L	16
6	Pin, Retaining, 3/4" dia. x 7-3/8" long and clip	28-112-007	2
7	Pin, Retaining, 1/2" dia. x 3" long	28-1/2-005	2
8	Pin, Cotter, 1/8"	A/L	10
9	Clamp, Beam	28-145-002	8
10	Bolt, 1/2"-13 UNC x 2-1/2" long, Grade 5	A/L	8
11	Nut, 1/2"-13 UNC, Grade 5	A/L	8
12	Washer, Flat 1/2"	A/L	16
13	Washer, Lock, 1/2"	A/L	8
14	Knob, Scrw, 3/8"-16 (2K only)	189-50	2
15	Pin, Retaining, 3/4" dia. x 4-1/2" long (2K only)	AHA-RP4.5	8

a/k Available only with purchase of kit

E
N
G
L
I
S
H

WARNING LABEL IDENTIFICATION

MAKE SURE ALL WARNING LABELS ARE IN PLACE!

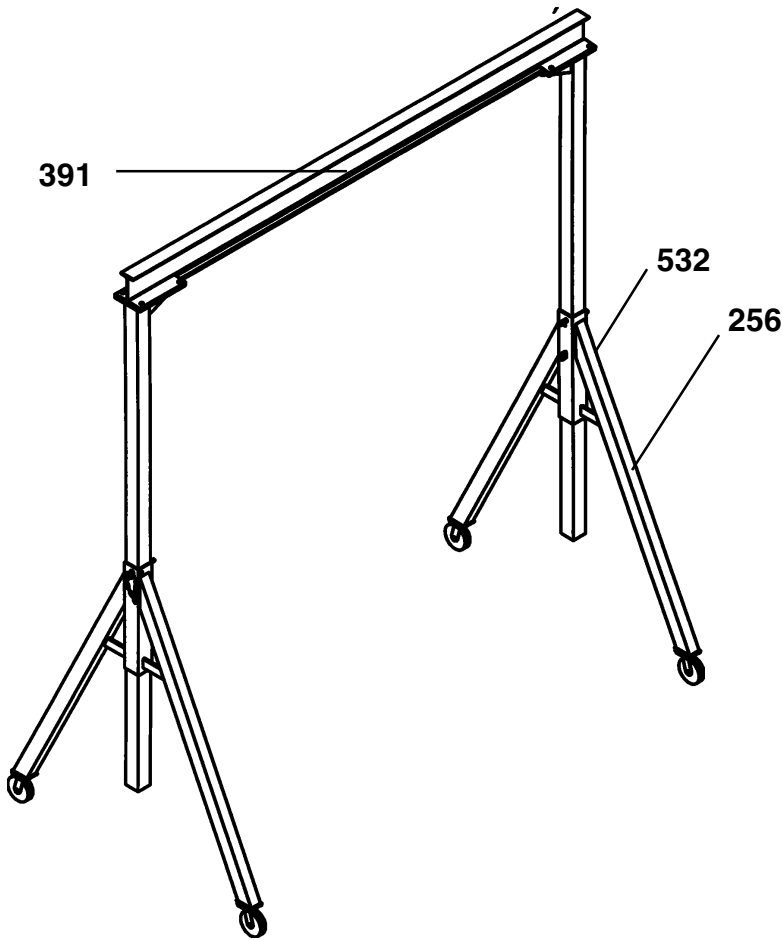

256

⚠ WARNING

- Lock all wheels in perpendicular position to one another before loading.
- Check for damage and be sure all hardware is tight before each use. Remove from service and repair immediately if necessary.
- Never exceed capacity printed on I-Beam.
- Never move or load unless both height adjustment pins are fully inserted.
- Never cantilever loads off of one end.
- Always include weight of hoist and trolley when calculating load.
- Use on level concrete or equal surface.
- Stand clear of hanging tools.
- Keep clear of all overhead obstructions especially electrical equipment when moving gantry.
- See owners manual for inspection and testing requirements.

⚠ ADVERTENCIA

- Asegure todas las ruedas en la posición perpendicular antes de cargar la unidad.
- Compruebe por daños y asegúrese que toda la ferretería está sujeta antes de cada uso. Retire del servicio y repare inmediatamente si es necesario.
- Nunca exceda la capacidad impresa en la viga.
- Nunca mueva o cargue la unidad a no ser que ambos pasadores de ajuste de altura estén completamente insertos.
- Nunca deje que la carga sobresalga en un solo extremo.
- Siempre incluya el peso de la grúa y la carretilla cuando se calcule la carga.
- Use en cemento a nivel o en una superficie equivalente.
- Manténgase alejado de herramientas que cuelguen.
- Manténgase alejado de todas las obstrucciones en lo alto especialmente equipos eléctricos cuando se mueva la grúa.
- Vea el manual del propietario para los requisitos de inspección y pruebas.

⚠ AVERTISSEMENT

- Bloquer chaque roue en position perpendiculaire à une autre avant de charger.
- Contrôler tout dommage et s'assurer que tout le matériel soit bien serré avant chaque utilisation. Retirer du service et réparer immédiatement si nécessaire.
- Ne jamais excéder la capacité imprimée sur la poutre.
- Ne jamais déplacer ou charger sans que les deux goupilles d'ajustement de hauteur ne soient complètement insérées.
- Ne jamais cantilever les charges d'une des extrémités.
- Toujours inclure le poids de levage et de charriage pour calculer la charge.
- Utiliser sur un ciment à niveau ou sur une surface équivalente.
- Vous écarter de tout outil pendant.
- Éviter toutes les obstructions élevées, surtout l'équipement électrique, pendant le mouvement du portique.
- Voir le guide d'utilisation pour les impératifs d'inspection et de vérification.

VESTIL MANUFACTURING CORPORATION
Phone (260) 665-7586 • www.vestil.com
256 • Revision 06/03

532



*Product safety signs or labels should be periodically inspected and cleaned by the product users as necessary to maintain good legibility for safe viewing distance . . . ANSI 535.4 (10.21)
Contact manufacturer for replacement labels if needed.

391

