

PALLET MASTER/SERVER - PMPS-60-DC

APPROX WEIGHT: 1035.60 lbs.
 DOES NOT INCLUDE WEIGHT OF POWER OR PACKAGING!!!

*** ANY ADDITIONS, DELETIONS, OR OMISSIONS MUST BE CORRECTED ON THIS DRAWING AS THIS DRAWING WILL BE CONSIDERED ALL INCLUSIVE ***
 ALL GRAPHICS PROVIDED ARE FOR REFERENCE ONLY. IF CERTAIN DIMENSIONS ARE CRITICAL PLEASE VERIFY THOSE DIMENSIONS WITH YOUR SALESPERSON

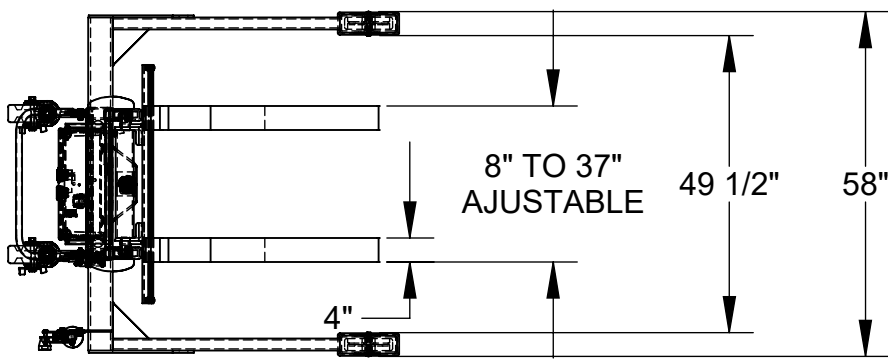

STANDARD FEATURES

- MODEL NUMBER IS: PMPS-60-DC
- OVERALL WIDTH IS 58"
- STRADDLE INNER DIMENSION IS 49 1/2"
- OVERALL LENGTH IS 66"
- OVERALL RAISED HEIGHT IS 101"
- OVERALL LOWERED HEIGHT IS 87"
- FORK RAISED HEIGHT IS 60"
- FORK LOWERED HEIGHT IS 3"
- MAXIMUM FORK HEIGHT BEFORE CARRIAGE EXCEEDS HEIGHT OF MAST IS 42"
- FORK CAPACITY (EVENLY DISTRIBUTED) IS 4000 LBS.
- FORKS ARE 1 1/2" THICK x 4" WIDE x 36" LONG
- MAXIMUM FORK SPREAD IS 37" O.D.
- FLOOR LOCK
- 12V DC POWER UNIT
- HANDHELD PUSH BUTTON CONTROL, W/ 8ft.EXTENDED COIL CORD (NOT SHOWN)
- ALL STEEL CONSTRUCTION (ASTM A-36 MINIMUM)
- DURABLE LIQUID PAINT BLUE FINISH

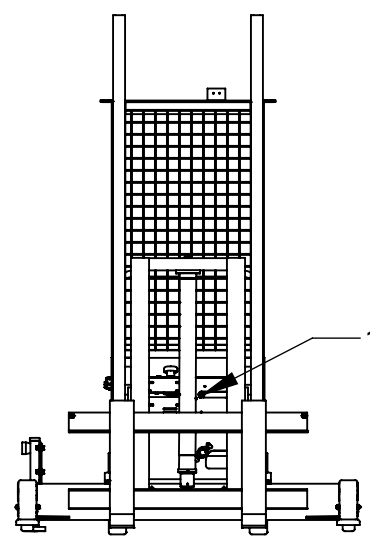
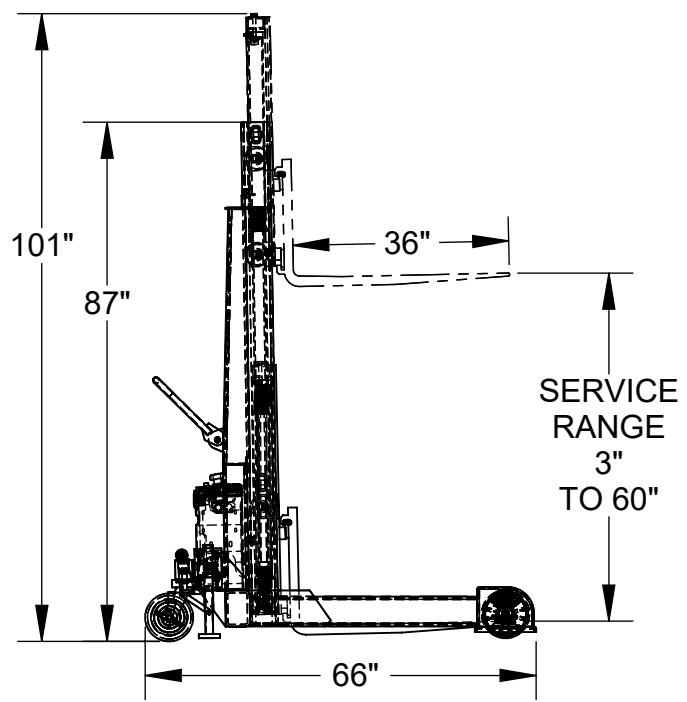

SPECIAL FEATURES

NONE

DIMENSION TOLERANCE ± 1/4"

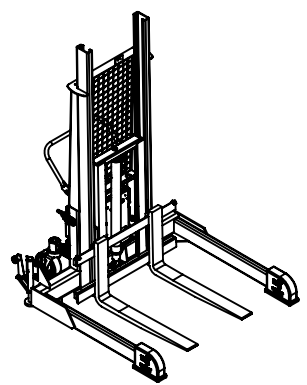

12V DC POWER

ON-BOARD BATTERY INDICATOR & CHARGER
 CONTACT FACTORY FOR OTHER POWER OPTIONS

APPROVAL	I, THE UNDERSIGNED, AGREE THAT THE PRODUCT AS REPRESENTED SATISFIES DESIGN AND DIMENSION REQUIREMENTS. I ALSO ACKNOWLEDGE MY DUTY TO CONFIRM PRODUCT AND INSTALLATION COMPLIANCE WITH ALL APPLICABLE FEDERAL, STATE AND LOCAL REGULATIONS AND STANDARDS.	
	UNITS REQUIRING APPROVAL DRAWINGS OR MODIFIED ARE NON-RETURNABLE	
	[] As drawn	[] As marked
	Signed: _____	Date: _____
	Printed Name: _____	
	<i>LEAD TIME WILL START UPON RECEIPT OF SIGNED APPROVAL DRAWING</i>	

DISTRIBUTOR'S NAME:		P.O.#
VESTIL MANUFACTURING		X
DRAWN BY: A.FORD		DATE: 8/3/07
REFERENCE: X		SCALE: 1:32
QUOTED LEAD TIME: X	QUOTE # X	FILE NAME: 15-007-021
		SALES: X