

PALLET MASTER/SERVER - PMPS-50-DC

APPROX WEIGHT: 1002.17 lbs.
DOES NOT INCLUDE WEIGHT OF POWER OR PACKAGING!!!

*** ANY ADDITIONS, DELETIONS, OR OMISSIONS MUST BE CORRECTED ON THIS DRAWING AS THIS DRAWING WILL BE CONSIDERED ALL INCLUSIVE ***

ALL GRAPHICS PROVIDED ARE FOR REFERENCE ONLY. IF CERTAIN DIMENSIONS ARE CRITICAL PLEASE VERIFY THOSE DIMENSIONS WITH YOUR SALESPERSON

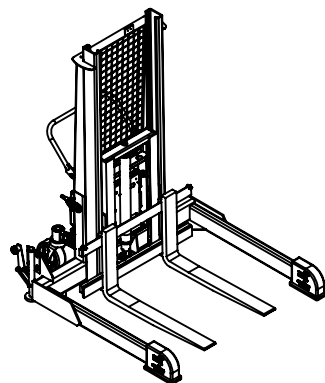
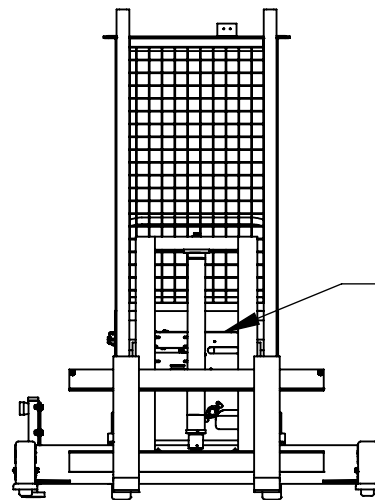
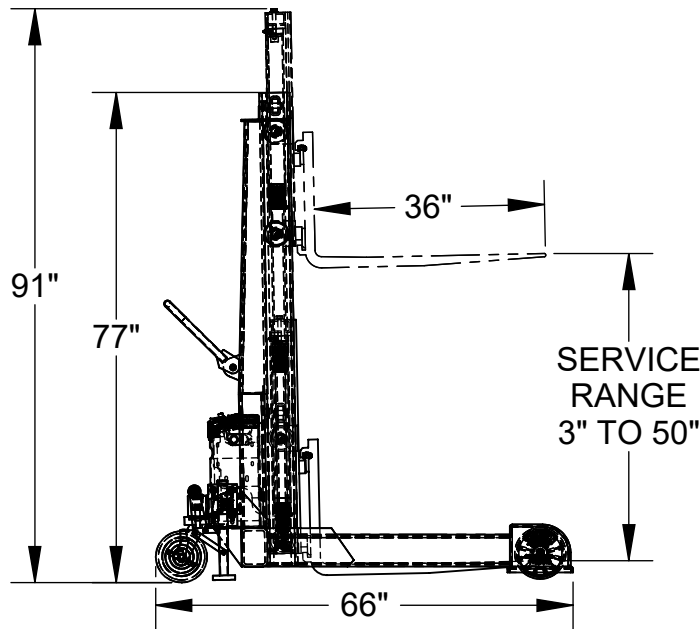
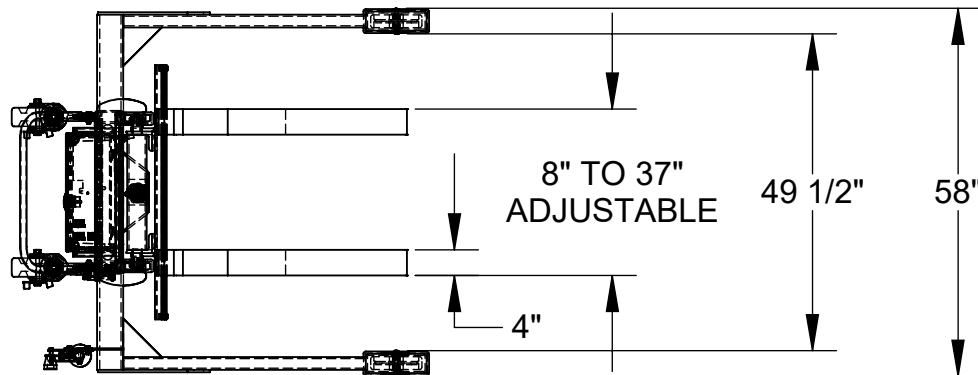

STANDARD FEATURES

- MODEL NUMBER IS PMPS-50-DC
- OVERALL WIDTH IS 58"
- STRADDLE INNER DIMENSION IS 49 1/2"
- OVERALL LENGTH IS 66"
- OVERALL RAISED HEIGHT IS 91"
- OVERALL LOWERED HEIGHT IS 77"
- MAXIMUM FORK HEIGHT BEFORE CARRIAGE EXCEEDS HEIGHT OF MAST IS 36 1/2"
- FORK CAPACITY (EVENLY DISTRIBUTED) IS 4000 LBS
- FORKS ARE 1 1/2" THICK x 4" WIDE x 36" LONG
- MAXIMUM FORK SPREAD IS 37" O.D.
- FLOOR LOCK
- 12V DC POWER UNIT
- HANDHELD PUSH BUTTON CONTROL, W/ 8ft. EXTENDED COIL CORD (NOT SHOWN)
- ALL STEEL CONSTRUCTION (ASTM A-36 MINIMUM)
- DURABLE LIQUID PAINT BLUE FINISH

SPECIAL FEATURES

NONE

12V DC POWER UNIT

DIMENSION TOLERANCE $\pm 1/4"$

APPROVAL

I, THE UNDERSIGNED, AGREE THAT THE PRODUCT AS REPRESENTED SATISFIES DESIGN AND DIMENSION REQUIREMENTS. I ALSO ACKNOWLEDGE MY DUTY TO CONFIRM PRODUCT AND INSTALLATION COMPLIANCE WITH ALL APPLICABLE FEDERAL, STATE AND LOCAL REGULATIONS AND STANDARDS.
UNITS REQUIRING APPROVAL DRAWINGS OR MODIFIED ARE NON-RETURNABLE
[] As drawn [] As marked

Signed: _____ Date: _____

Printed Name: _____

LEAD TIME WILL START UPON RECEIPT OF SIGNED APPROVAL DRAWING

12V DC POWER

ON-BOARD BATTERY INDICATOR & CHARGER
CONTACT FACTORY FOR OTHER POWER OPTIONS

DISTRIBUTOR'S NAME:		P.O.#
VESTIL MANUFACTURING		X
DRAWN BY: A.FORD		W.O.#
DATE: 8/3/07		X
REFERENCE: X	SCALE: 1:30	SALES: X
QUOTED LEAD TIME: X	QUOTE #	FILE NAME:
	X	15-007-020