

STATIONARY HYDRAULIC DRUM DUMPER - HDD-36-15-S

APPROX WEIGHT: 636.49 lbs.
 DOES NOT INCLUDE WEIGHT OF POWER OR PACKAGING!!!

*** ANY ADDITIONS, DELETIONS, OR OMISSIONS MUST BE CORRECTED ON THIS DRAWING AS THIS DRAWING WILL BE CONSIDERED ALL INCLUSIVE ***

ALL GRAPHICS PROVIDED ARE FOR REFERENCE ONLY. IF CERTAIN DIMENSIONS ARE CRITICAL PLEASE VERIFY THOSE DIMENSIONS WITH YOUR SALESPERSON

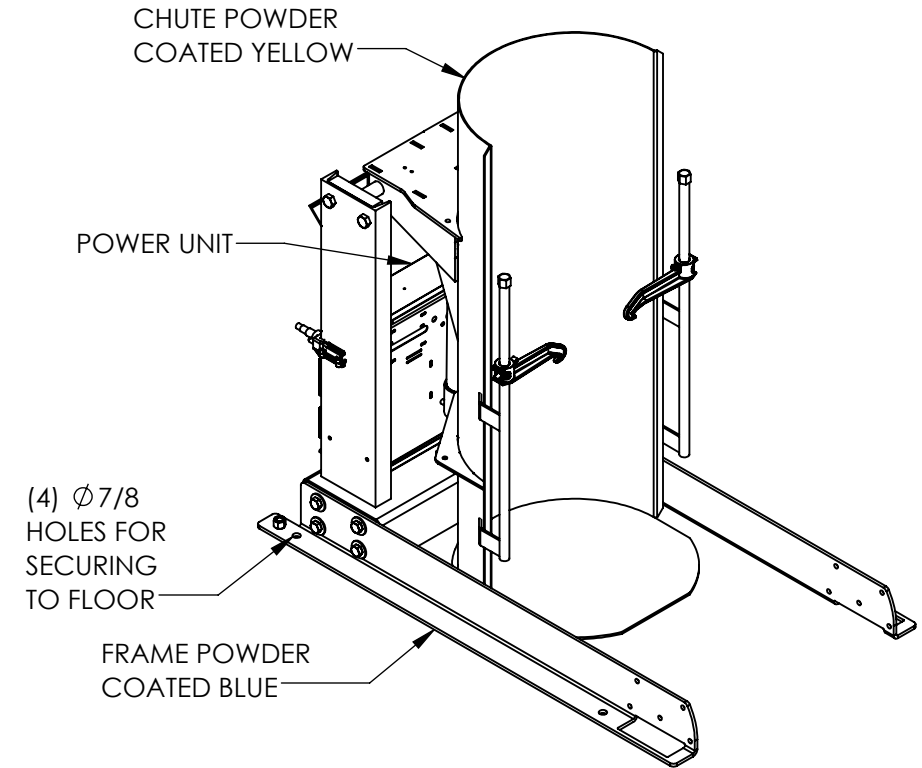
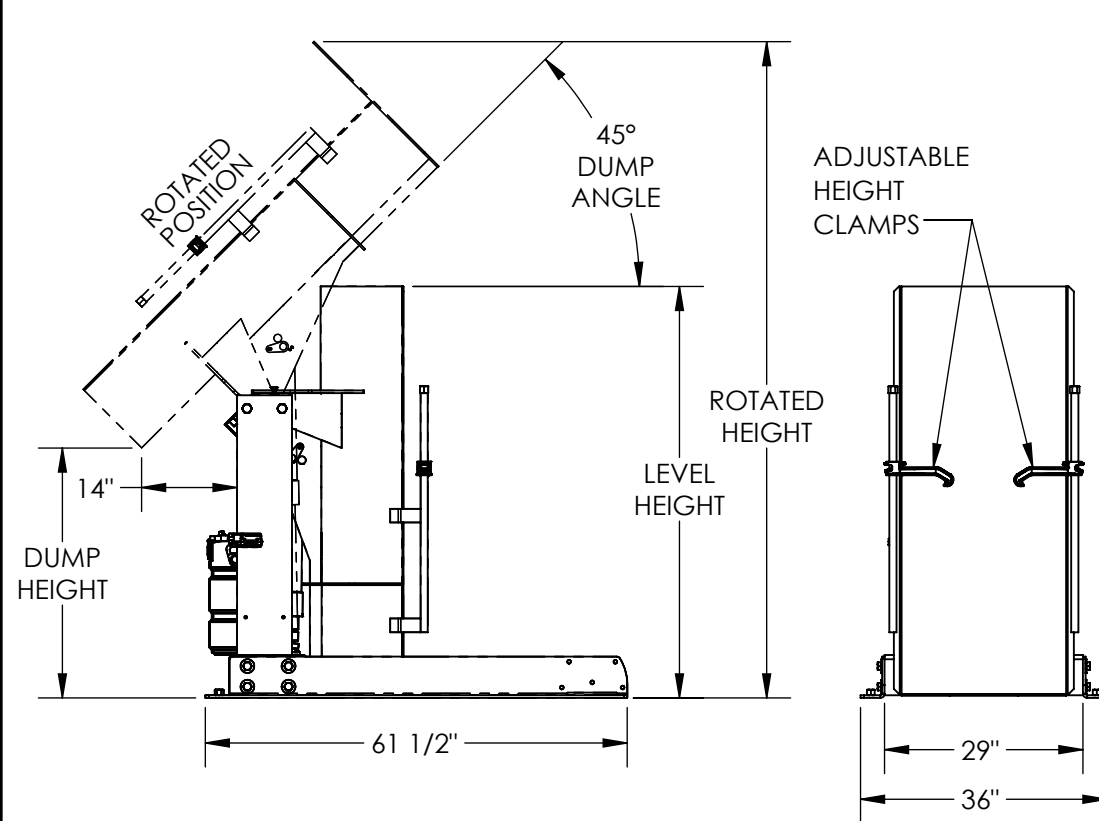

DIMENSION TOLERANCE ± 1/4"

STANDARD FEATURES

MODEL NUMBER IS HDD-36-15-S
 DUMP HEIGHT IS 36"
 MAX CAPACITY IS 1,500 LBS
 OVERALL WIDTH IS 36"
 OVERALL LENGTH IS 61 1/2"
 LEVEL HEIGHT IS 60"
 ROTATED HEIGHT IS 95 3/4"
 DUMP ANGLE IS 45°
 ACCEPTS DRUM SIZE: Ø16 1/2" TO Ø23 1/2" (ROUND) X 27 1/2" TO 39 1/2" TALL
 ALL STEEL CONSTRUCTION
 DURABLE BAKED IN POWDER COATED FINISH (BASE BLUE & CHUTE YELLOW)
 2-FUNCTION HANDHELD CONTROL WITH 18"-90" COIL CORD
 WARNING: CHECK STATE AND LOCAL CODES!!!

115V SINGLE PHASE AC POWER

CONTACT FACTORY FOR
 OTHER POWER OPTIONS

SPECIAL FEATURES

NONE

APPROVAL

I, THE UNDERSIGNED, AGREE THAT THE PRODUCT AS REPRESENTED SATISFIES DESIGN AND DIMENSION REQUIREMENTS. I ALSO ACKNOWLEDGE MY DUTY TO CONFIRM PRODUCT AND INSTALLATION COMPLIANCE WITH ALL APPLICABLE FEDERAL, STATE AND LOCAL REGULATIONS AND STANDARDS.
UNITS REQUIRING APPROVAL DRAWINGS OR MODIFIED ARE NON-RETURNABLE

[] As drawn [] As marked

Signed: _____ Date: _____

Printed Name: _____

LEAD TIME WILL START UPON RECEIPT OF SIGNED APPROVAL DRAWING

DISTRIBUTOR'S NAME:		P.O.#
VESTIL MANUFACTURING		X
DRAWN BY: CRM		W.O.#
DATE: 10/21/2010		X
REFERENCE: X	SCALE: 1:28	SALES: X
QUOTED LEAD TIME: X	QUOTE #	FILE NAME:
X	X	09-007-122-002