

# PORTABLE HYDRAULIC DRUM DUMPER - HDD-36-7-P

APPROX WEIGHT: 698.87 lbs.  
 DOES NOT INCLUDE WEIGHT OF POWER OR PACKAGING!!!

\*\*\* ANY ADDITIONS, DELETIONS, OR OMISSIONS MUST BE CORRECTED ON THIS DRAWING AS THIS DRAWING WILL BE CONSIDERED ALL INCLUSIVE \*\*\*

ALL GRAPHICS PROVIDED ARE FOR REFERENCE ONLY. IF CERTAIN DIMENSIONS ARE CRITICAL PLEASE VERIFY THOSE DIMENSIONS WITH YOUR SALESPERSON

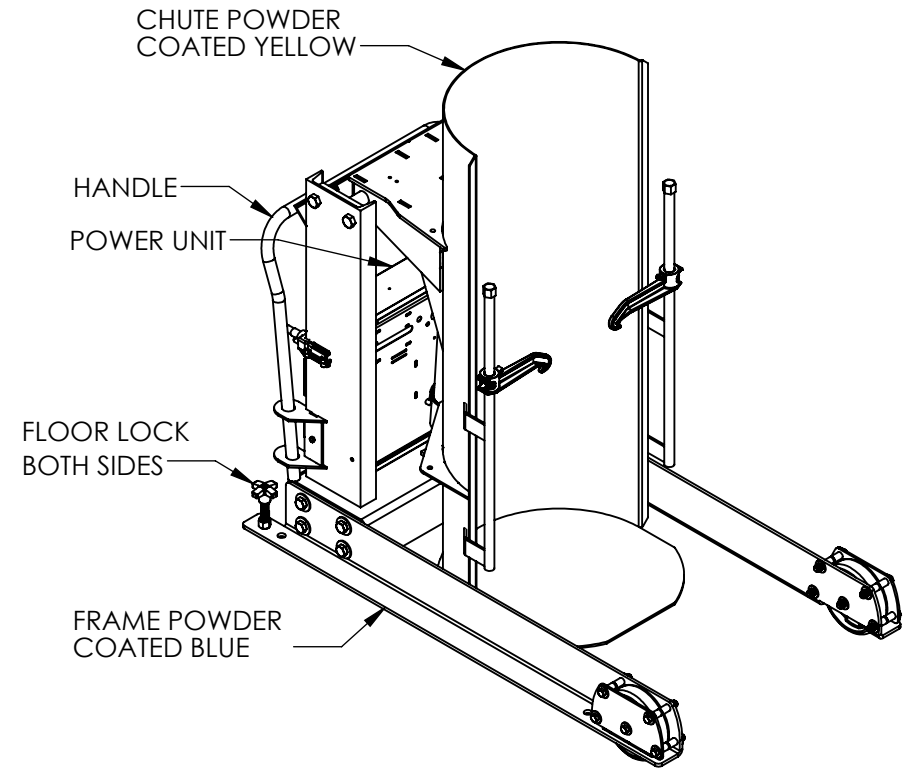
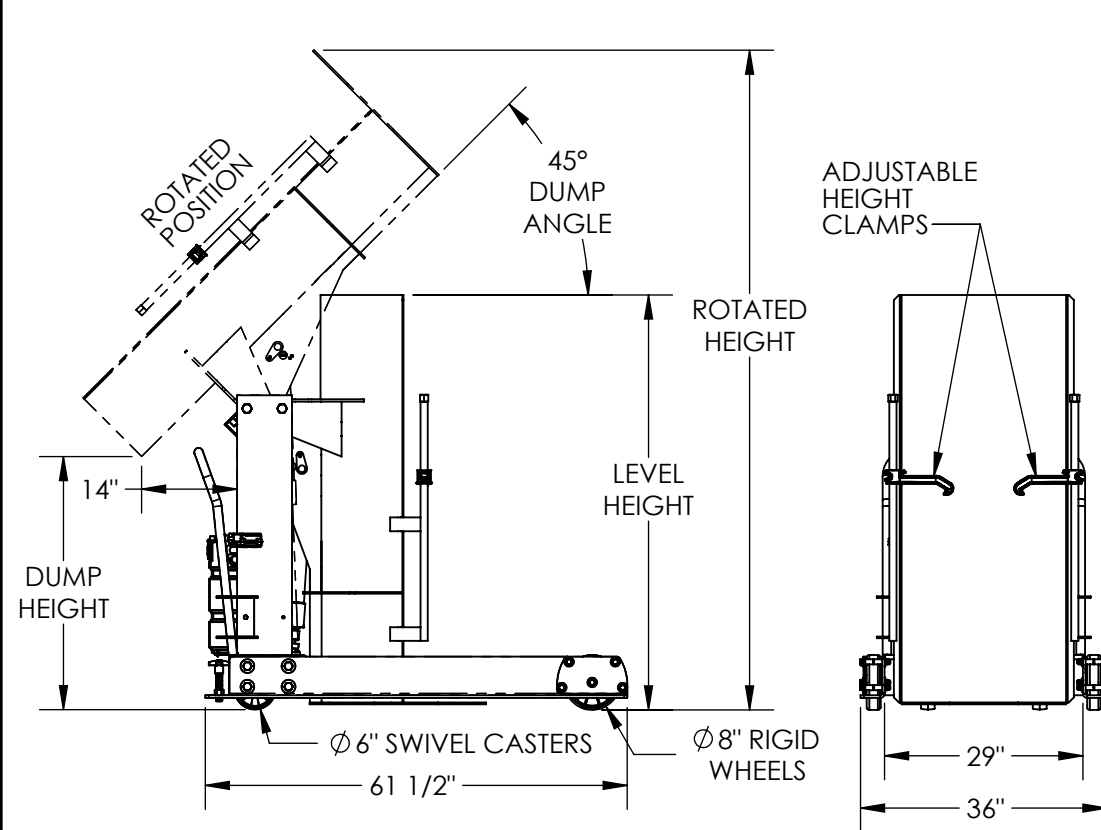

DIMENSION TOLERANCE ± 1/4"

## STANDARD FEATURES

- MODEL NUMBER IS HDD-36-7-P
- DUMP HEIGHT IS 36"
- MAX CAPACITY IS 750 LBS
- OVERALL WIDTH IS 36"
- OVERALL LENGTH IS 61 1/2"
- LEVEL HEIGHT IS 63 3/4"
- ROTATED HEIGHT IS 96"
- DUMP ANGLE IS 45°
- ACCEPTS DRUM SIZE: Ø16 1/2" TO Ø23 1/2" (ROUND) X 27 1/2" TO 39 1/2" TALL
- ALL STEEL CONSTRUCTION
- DURABLE BAKED IN POWDER COATED FINISH (BASE BLUE & CHUTE YELLOW)
- 2-FUNCTION HANDHELD CONTROL WITH 18"-90" COIL CORD
- WARNING: CHECK STATE AND LOCAL CODES!!!

## SPECIAL FEATURES

NONE

## 115V SINGLE PHASE AC POWER

CONTACT FACTORY FOR OTHER POWER OPTIONS

APPROVAL

I, THE UNDERSIGNED, AGREE THAT THE PRODUCT AS REPRESENTED SATISFIES DESIGN AND DIMENSION REQUIREMENTS. I ALSO ACKNOWLEDGE MY DUTY TO CONFIRM PRODUCT AND INSTALLATION COMPLIANCE WITH ALL APPLICABLE FEDERAL, STATE AND LOCAL REGULATIONS AND STANDARDS.  
**UNITS REQUIRING APPROVAL DRAWINGS OR MODIFIED ARE NON-RETURNABLE**

[ ] As drawn [ ] As marked

Signed: \_\_\_\_\_ Date: \_\_\_\_\_

Printed Name: \_\_\_\_\_

LEAD TIME WILL START UPON RECEIPT OF SIGNED APPROVAL DRAWING

DISTRIBUTOR'S NAME:		P.O.#
VESTIL MANUFACTURING		X
DRAWN BY: CRM		DATE: 01/13/2017
REFERENCE: X		SALES: X
QUOTED LEAD TIME: X		SCALE: 1:28
QUOTE # X		FILE NAME: 09-007-126