



MODEL W1867/W1868/W1869 CYCLONE DUST COLLECTORS



OWNER'S MANUAL

(FOR MODELS MANUFACTURED SINCE 11/18)

Phone: (360) 734-3482 • Online Technical Support: techsupport@woodstockint.com

COPYRIGHT © JANUARY, 2019 BY WOODSTOCK INTERNATIONAL, INC.
WARNING: NO PORTION OF THIS MANUAL MAY BE REPRODUCED IN ANY SHAPE OR FORM WITHOUT
THE WRITTEN APPROVAL OF WOODSTOCK INTERNATIONAL, INC.

#20207KBES Printed in Taiwan



WARNING!

This manual provides critical safety instructions on the proper setup, operation, maintenance, and service of this machine/tool. Save this document, refer to it often, and use it to instruct other operators.

Failure to read, understand and follow the instructions in this manual may result in fire or serious personal injury—including amputation, electrocution, or death.

The owner of this machine/tool is solely responsible for its safe use. This responsibility includes but is not limited to proper installation in a safe environment, personnel training and usage authorization, proper inspection and maintenance, manual availability and comprehension, application of safety devices, cutting/sanding/grinding tool integrity, and the usage of personal protective equipment.

The manufacturer will not be held liable for injury or property damage from negligence, improper training, machine modifications or misuse.



WARNING!

Some dust created by power sanding, sawing, grinding, drilling, and other construction activities contains chemicals known to the State of California to cause cancer, birth defects or other reproductive harm. Some examples of these chemicals are:

- Lead from lead-based paints.
- Crystalline silica from bricks, cement and other masonry products.
- Arsenic and chromium from chemically-treated lumber.

Your risk from these exposures varies, depending on how often you do this type of work. To reduce your exposure to these chemicals: Work in a well ventilated area, and work with approved safety equipment, such as those dust masks that are specially designed to filter out microscopic particles.

Contents

INTRODUCTION	2	OPERATIONS	36
Woodstock Technical Support	2	General	36
Machine Differences	2	Operation Overview	36
Machine Specifications	3	ACCESSORIES	37
Identification	5	Cyclone Dust Collector Accessories	37
Controls & Components	6	MAINTENANCE	39
SAFETY	7	General	39
Standard Machinery Safety Instructions	7	Emptying/Replacing Collection Drum Bag..	39
Additional Safety for Dust Collectors	9	Cleaning Canister Filter	40
ELECTRICAL	10	SERVICE	41
W1867 110V Circuit Requirements	10	General	41
Grounding Requirements.....	11	Removing/Replacing Canister Filter & Bag.	41
Extension Cords	11	Troubleshooting.....	43
W1868/W1869 220V Circuit Requirements.	12	Electrical Safety Instructions.....	45
Grounding Requirements.....	13	Electrical Components	46
Extension Cords	13	W1867 Wiring Diagram	47
SETUP	14	W1868/W1869 Wiring Diagram.....	48
Unpacking	14	PARTS	49
Items Needed for Setup.....	14	W1867/W1868/W1869 Parts	49
Inventory	15	W1867 Parts List.....	50
Machine Placement	17	W1868 Parts List.....	51
Assembly.....	18	W1869 Parts List.....	52
Test Run.....	26	W1867/W1868 Labels & Cosmetics.....	53
DESIGNING THE SYSTEM	27	W1869 Labels & Cosmetics	54
General	27	WARRANTY	57
Duct Material	27		
System Design	29		
System Grounding.....	35		





INTRODUCTION

Woodstock Technical Support

This machine has been specially designed to provide many years of trouble-free service. Close attention to detail, ruggedly built parts and a rigid quality control program assure safe and reliable operation.

Woodstock International, Inc. is committed to customer satisfaction. Our intent with this manual is to include the basic information for safety, setup, operation, maintenance, and service of this product.

We stand behind our machines! In the event that questions arise about your machine, please contact Woodstock International Technical Support at (360) 734-3482 Ext. 2 or send e-mail to: techsupport@woodstockint.com. Our knowledgeable staff will help you troubleshoot problems and process warranty claims.

If you need the latest edition of this manual, you can download it from <http://www.woodstockint.com/manuals>.

If you have comments about this manual, please contact us at:

Woodstock International, Inc.
Attn: Technical Documentation Manager
P.O. Box 2309
Bellingham, WA 98227
Email: manuals@woodstockint.com

Machine Differences

Model W1867:

- 1.5 HP 110V Single-Phase Motor
- 6" Dust Port Inlet with 2 x 4" Adapter
- 868 CFM @ 1.8" SP
- 1-Micron Canister Filter
- 20-Gallon Collection Drum

Model W1868:

- 2 HP 220V Single-Phase Motor
- 7" Dust Port Inlet with 3 x 4" Adapter
- 1023 CFM @ 1.2" SP
- 1-Micron Canister Filter
- 20-Gallon Collection Drum

Model W1869:

- 3 HP 220V Single-Phase Motor
- 8" Dust Port with 3 x 4" Adapter
- 1941 CFM @ 2.9" SP
- 1-Micron Canister Filter
- 35-Gallon Collection Drum

MACHINE SPECIFICATIONS



© Woodstock International, Inc. • Phone: (800) 840-8420 • Web: www.shopfox.biz

W1867/W1868/W1869 CYCLONE DUST COLLECTORS

Model Number	W1867	W1868	W1869
Product Dimensions			
Weight	265 lbs.	285 lbs.	348 lbs.
Width (side-to-side) x Depth (front-to-back) x Height	27 ¹ / ₂ " x 44" x 70"	28 ¹ / ₂ " x 52" x 70"	31" x 54" x 82"
Footprint (Length x Width)	32 ¹ / ₂ " x 24"	36" x 26"	40" x 31"
Shipping Dimensions			
Type	Cardboard Box 1, Main Body		
Weight	199 lbs.	213 lbs.	820 lbs.
Width x Depth x Height	43" x 29" x 23"	43" x 29" x 23"	38" x 30" x 46"
Type	Cardboard Box 2, Stand & Support Arms		
Weight	39 lbs.		42 lbs.
Width x Depth x Height	50" x 18" x 8"		59" x 19" x 8"
Type	Cardboard Box 3, Canister Filter & Collection Drum		
Weight	40 lbs.	42 lbs.	52 lbs.
Width x Depth x Height	22" x 22" x 28"		27" x 27" x 45"
Electrical			
Power Requirement	110V, Single-Phase, 60 Hz	220V, Single-Phase, 60 Hz	
Full-Load Current Rating	15A	9A	15A
Minimum Circuit Size	20A	15A	20A
Connection Type	Cord & Plug		
Power Cord Included	Yes		
Power Cord Length	6'		
Power Cord Gauge	14 AWG		12 AWG
Plug Included	Yes		
Included Plug Type	5-15	6-15	6-20
Switch Type	Remote Control Magnetic Switch w/Overload Protection		
Motor			
Type	TEFC Capacitor-Start Induction		
Horsepower	1.5 HP	2 HP	3 HP
Phase	Single-Phase		
Amps	15A	9A	15A
Speed	3450 RPM		
Power Transfer	Direct Drive		
Bearings	Shielded & Permanently Lubricated		
Centrifugal Switch/Contacts Type	External		



Model W1867/W1868/W1869 (For Machines Mfd. Since 11/18)

Model Number	W1867	W1868	W1869
Operation			
Dust Collector Type	Two-Stage (Cyclone)		
Approved Dust Types	Wood		
Filter Type	Pleated Cartridge, Spun-Bond Polyester		
Air Flow Performance	868 CFM @ 1.8" SP	1023 CFM @ 1.2" SP	1941 CFM @ 2.9" SP
Max. Static Pressure (at 0 CFM)	9.7"	10.9"	11.0"
Main Inlet Size	6"	7"	8"
Inlet Adapter Included	Yes		
Number of Adapter Inlets	2	3	
Adapter Inlet Size	4"	4"	
Machine Collection Capacity	2 Machines	3 Machines	
Max. Material Collection Capacity	20 Gallons		38 Gallons
Bag Information			
Number of Filter Bags	1		
Number of Collection Drum Bags	1		
Filter Bag Diameter	20"		
Filter Bag Length	23"		
Collection Drum Bag Diameter	30"		39"
Collection Drum Bag Length	41"		56"
Canister Filter Information			
Number of Canister Filters	1		
Filtration Rating	1 Micron		
Canister Filter Diameter	14½"		
Canister Filter Length	24"		39⅜"
Filter Surface Area	28.1 sq. ft.		45.2 sq. ft.
Impeller Information			
Impeller Type	Radial Fin		
Impeller Size	12¾"	13"	15"
Impeller Blade Thickness	¼"	⅛"	
Construction			
Dust Collection Bags	Clear Plastic		
Base	Steel		
Frame	Steel		
Impeller	Cast Aluminum	Steel	
Impeller Housing	Steel		
Body	Steel		
Collection Drum	Steel		
Paint Type/Finish	Powder Coated		
Manufacturer Specifications			
Country of Origin	Taiwan		
Warranty	2 Years		
Approx. Assembly & Setup Time	1 Hour		
Serial Number Location	ID Label on Impeller Housing		
Sound Rating	78 dB		79 dB
ISO 9001 Factory	Yes		

Identification

Become familiar with the names and locations of the controls and features shown below to better understand the instructions in this manual.

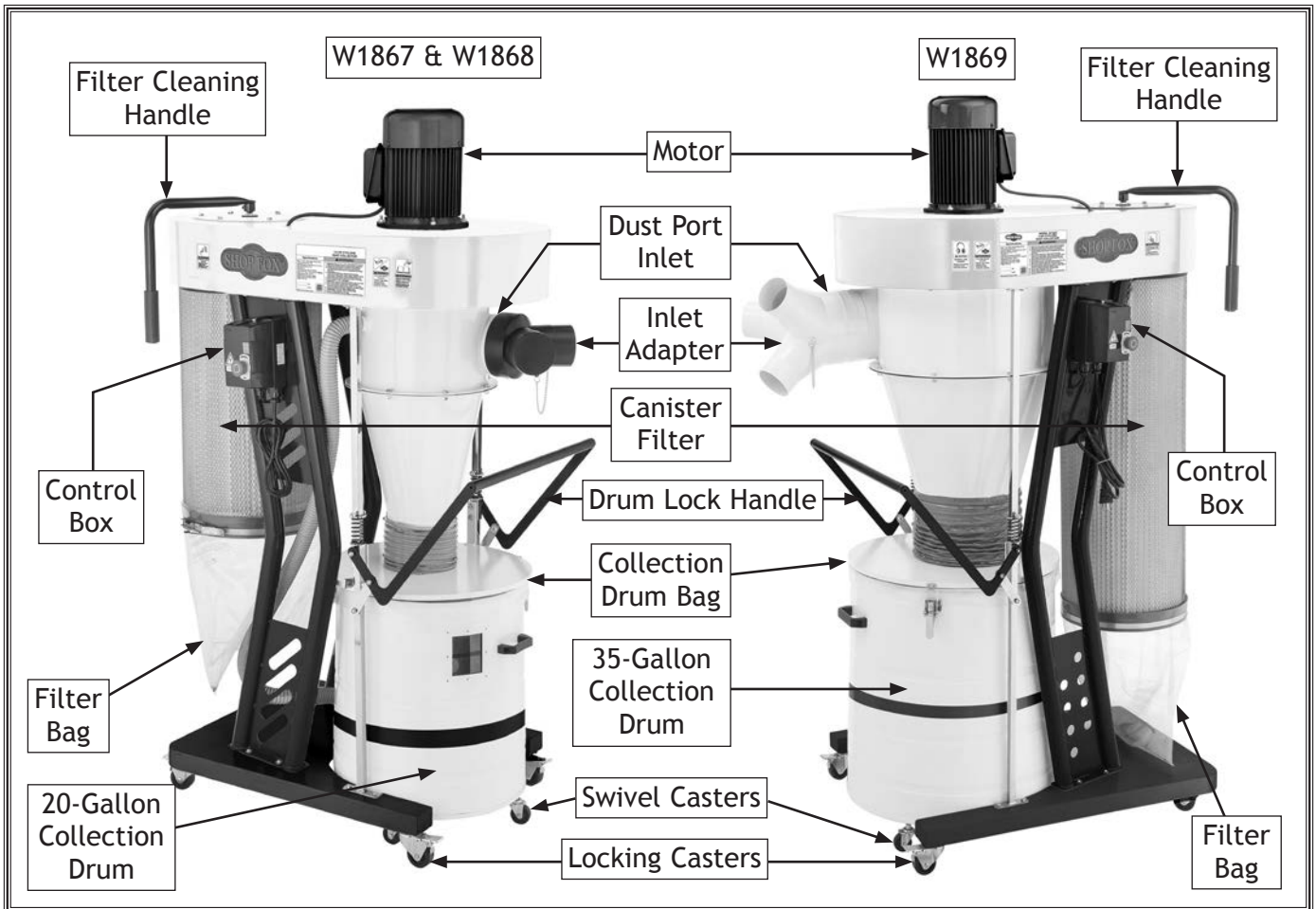

⚠️ WARNING
 Like all machinery there is potential danger when operating this machine. Accidents are frequently caused by lack of familiarity or failure to pay attention. Use this machine with respect and caution to decrease the risk of operator injury. If normal safety precautions are overlooked or ignored, serious personal injury may occur.

⚠️ WARNING
 No list of safety guidelines can be complete. Every shop environment is different. Always consider safety first, as it applies to your individual working conditions. Use this and other machinery with caution and respect. Failure to do so could result in serious personal injury, damage to equipment, or poor work results.

Controls & Components

Refer to **Figures 2-3** and the following descriptions to become familiar with the basic controls and components of this machine. Understanding these items and how they work will help you understand the rest of the manual and stay safe when operating this machine.

- A. **Filter Cleaning Handle:** Turns paddles inside canister filter to knock dust cake off filter pleats, cleaning filter and helping maintain good air flow.
- B. **Control Box:** Controls motor operation with a thermally protected magnetic switch. Houses an RF receiver for operation via remote control.
- C. **Removable Filter Bag:** Collects fine dust from filter area.
- D. **Inlet Adapter:** Allows connection of two 4" ducts (Model W1867) or three 4" ducts (Models W1868 & W1869) to main dust port inlet.
- E. **Collection Drum Lock Handle:** Secures dust collection drum to lid when pressed down. Releases collection drum from lid when pulled up.
- F. **Collection Drum Inspection Window:** Allows operator to see when collection drum needs to be emptied.

- G. **Remote Control:** Green button turns motor **ON**. Red button turns motor **OFF**. Requires a 12V, type A27 battery.

Note: *The remote operates on radio frequency and has a 75-foot range. It does not need to be aimed at the control box to operate.*

WARNING



To reduce your risk of serious injury or damage to the machine, read this entire manual **BEFORE** using machine.

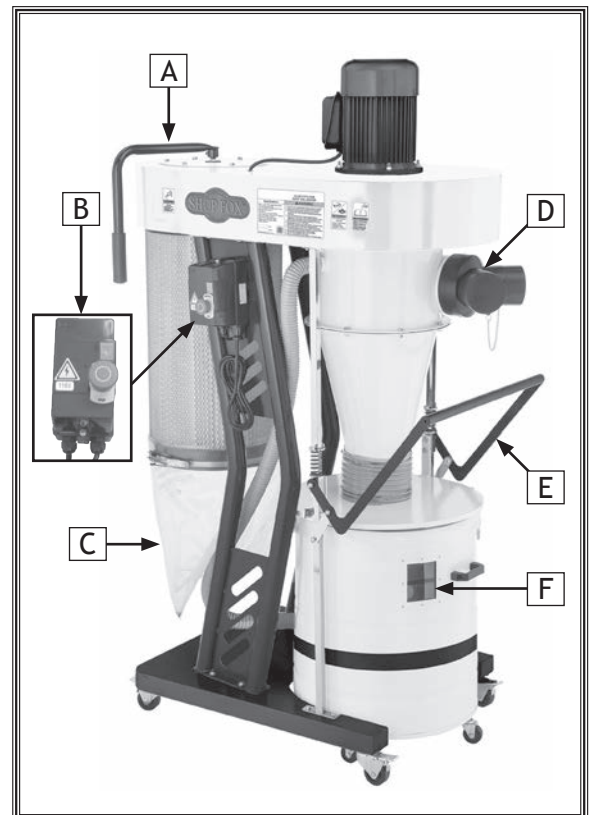

Figure 2. W1867-69 controls & components.

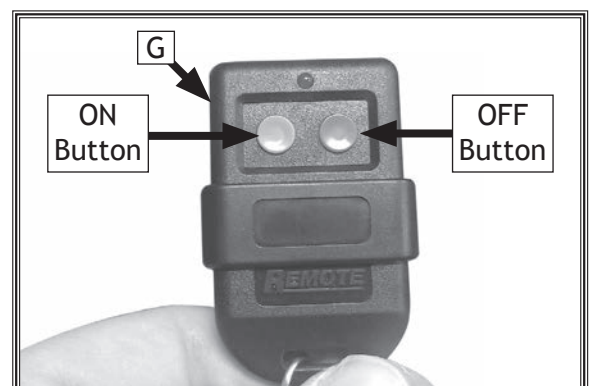

Figure 3. Remote control.

SAFETY

For Your Own Safety, Read Manual Before Operating Machine

The purpose of safety symbols is to attract your attention to possible hazardous conditions. This manual uses a series of symbols and signal words intended to convey the level of importance of the safety messages. The progression of symbols is described below. Remember that safety messages by themselves do not eliminate danger and are not a substitute for proper accident prevention measures—this responsibility is ultimately up to the operator!



Indicates an imminently hazardous situation which, if not avoided, **WILL** result in death or serious injury.



Indicates a potentially hazardous situation which, if not avoided, **COULD** result in death or serious injury.



Indicates a potentially hazardous situation which, if not avoided, **MAY** result in minor or moderate injury.

NOTICE

This symbol is used to alert the user to useful information about proper operation of the equipment or a situation that may cause damage to the machinery.

Standard Machinery Safety Instructions

OWNER'S MANUAL. Read and understand this owner's manual **BEFORE** using machine.

TRAINED OPERATORS ONLY. Untrained operators have a higher risk of being hurt or killed. Only allow trained/supervised people to use this machine. When machine is not being used, disconnect power, remove switch keys, or lock-out machine to prevent unauthorized use—especially around children. Make workshop kid proof!

DANGEROUS ENVIRONMENTS. Do not use machinery in areas that are wet, cluttered, or have poor lighting. Operating machinery in these areas greatly increases the risk of accidents and injury.

MENTAL ALERTNESS REQUIRED. Full mental alertness is required for safe operation of machinery. Never operate under the influence of drugs or alcohol, when tired, or when distracted.

ELECTRICAL EQUIPMENT INJURY RISKS. You can be shocked, burned, or killed by touching live electrical components or improperly grounded machinery. To reduce this risk, only allow an electrician or qualified service personnel to do electrical installation or repair work, and always disconnect power before accessing or exposing electrical equipment.

DISCONNECT POWER FIRST. Always disconnect machine from power supply **BEFORE** making adjustments, changing tooling, or servicing machine. This eliminates the risk of injury from unintended startup or contact with live electrical components.

EYE PROTECTION. Always wear ANSI-approved safety glasses or a face shield when operating or observing machinery to reduce the risk of eye injury or blindness from flying particles. Everyday eyeglasses are not approved safety glasses.

WEARING PROPER APPAREL. Do not wear clothing, apparel, or jewelry that can become entangled in moving parts. Always tie back or cover long hair. Wear non-slip footwear to avoid accidental slips, which could cause loss of workpiece control.

HAZARDOUS DUST. Dust created while using machinery may cause cancer, birth defects, or long-term respiratory damage. Be aware of dust hazards associated with each workpiece material, and always wear a NIOSH-approved respirator to reduce your risk.

HEARING PROTECTION. Always wear hearing protection when operating or observing loud machinery. Extended exposure to this noise without hearing protection can cause permanent hearing loss.

REMOVE ADJUSTING TOOLS. Tools left on machinery can become dangerous projectiles upon startup. Never leave chuck keys, wrenches, or any other tools on machine. Always verify removal before starting!

INTENDED USAGE. Only use machine for its intended purpose—never make modifications without prior approval from Woodstock International. Modifying machine or using it differently than intended will void the warranty and may result in malfunction or mechanical failure that leads to serious personal injury or death!

AWKWARD POSITIONS. Keep proper footing and balance at all times when operating machine. Do not overreach! Avoid awkward hand positions that make workpiece control difficult or increase the risk of accidental injury.

CHILDREN & BYSTANDERS. Keep children and bystanders at a safe distance from the work area. Stop using machine if they become a distraction.

GUARDS & COVERS. Guards and covers reduce accidental contact with moving parts or flying debris—make sure they are properly installed, undamaged, and working correctly.

FORCING MACHINERY. Do not force machine. It will do the job safer and better at the rate for which it was designed.

NEVER STAND ON MACHINE. Serious injury may occur if machine is tipped or if the cutting tool is unintentionally contacted.

STABLE MACHINE. Unexpected movement during operation greatly increases risk of injury or loss of control. Before starting, verify machine is stable and mobile base (if used) is locked.

USE RECOMMENDED ACCESSORIES. Consult this owner's manual or the manufacturer for recommended accessories. Using improper accessories will increase risk of serious injury.

UNATTENDED OPERATION. To reduce the risk of accidental injury, turn machine **OFF** and ensure all moving parts completely stop before walking away. Never leave machine running while unattended.

MAINTAIN WITH CARE. Follow all maintenance instructions and lubrication schedules to keep machine in good working condition. A machine that is improperly maintained could malfunction, leading to serious personal injury or death.

CHECK DAMAGED PARTS. Regularly inspect machine for any condition that may affect safe operation. Immediately repair or replace damaged or mis-adjusted parts before operating machine.

MAINTAIN POWER CORDS. When disconnecting cord-connected machines from power, grab and pull the plug—NOT the cord. Pulling the cord may damage the wires inside, resulting in a short. Do not handle cord/plug with wet hands. Avoid cord damage by keeping it away from heated surfaces, high traffic areas, harsh chemicals, and wet/damp locations.

EXPERIENCING DIFFICULTIES. If at any time you experience difficulties performing the intended operation, stop using the machine! Contact Technical Support at (360) 734-3482.

Additional Safety for Dust Collectors

Long-term respiratory damage can occur from using dust collectors without proper use of a respirator. Fire or explosions can result in smoke inhalation, serious burns, or death—if machine is used to collect incorrect materials, is operated near potential explosion sources, or ducting is improperly grounded. Entanglement, amputation, or death can occur if hair, clothing, or fingers are pulled into the inlet. To reduce the risk of these hazards, operator and bystanders **MUST** completely heed the hazards and warnings below.

INTENDED USE. Collecting the wrong materials can result in serious inhalation hazards, fire, explosions, or machine damage. This machine is **ONLY** designed to collect wood dust and chips from woodworking machines. **DO NOT** use it to collect silica, polyurethane, toxic fumes, metal dust or shavings, lead paint, drywall, asbestos, biohazards, explosive dusts, flammable or combustible liquids or fumes, nor burning or smoking material.

WEAR A RESPIRATOR. Fine dust that is too small to be caught in filter will be blown into ambient air. Always wear a NIOSH-approved respirator during operation and for a short time after to reduce your risk of permanent respiratory damage. Never collect dust from any hazardous material.

IMPELLER HAZARDS. To reduce risk of entanglement or contact with impeller, **DO NOT** place hands, hair, clothing, or tools in or near open dust collection inlet during operation, and keep small animals and children away. The powerful suction could easily pull them into impeller.

HAZARDOUS DUST. Dust exposure created while using machinery may cause cancer, birth defects, or long-term respiratory damage. Be aware of dust hazards associated with each workpiece material, and always wear a NIOSH-approved respirator.

EMPTYING DUST. When emptying bag or drum, wear respirator and safety glasses. Empty dust away from ignition sources and into approved container.

OPERATING LOCATION. To reduce respiratory exposure to fine dust, locate permanently installed dust collectors away from working area or in another room. **DO NOT** place dust collector where it can be exposed to rain or moisture, which creates a shock hazard and will reduce life of machine.

POWER DISCONNECT. Turn machine **OFF**, disconnect from power supply, and allow impeller to completely stop before leaving machine unattended, or doing any maintenance or service.

REGULAR CLEANING. To reduce risk of starting a fire, regularly check/empty collection bags or drum to avoid buildup of fine dust, which can increase risk of fire. Regularly clean surrounding area where machine is operated—excessive dust buildup on overhead lights, heaters, electrical panels, or other heat sources will increase risk of fire.

SUSPENDED DUST PARTICLES. To reduce risk of death or injury caused by explosions or fires, **DO NOT** operate in areas where these risks are high, including spaces near pilot lights, open flames, or other ignition sources.

AVOIDING SPARKS. To reduce risk of fire, avoid collecting any metal objects or stones. These can possibly produce sparks when they strike impeller, which can smolder in wood dust for a long time before a fire is detected. If you accidentally cut into wood containing metal, immediately turn **OFF** dust collector, disconnect from power, and wait for impeller to stop. Then empty bag or drum into approved airtight metal container.

FIRE SUPPRESSION. Only operate dust collector in locations that contain fire suppression system or have fire extinguisher nearby.

STATIC ELECTRICITY. To reduce risk of fire or explosions caused by sparks from static electricity, ground all ducting using grounding wire.

DUST ALLERGIES. Dust from certain woods will cause an allergic reaction. Make sure you know what type of wood dust you will be exposed to in case of an allergic reaction.

ELECTRICAL

W1867 110V Circuit Requirements

This machine must be connected to the correct size and type of power supply circuit, or fire or electrical damage may occur. Read through this section to determine if an adequate power supply circuit is available. If a correct circuit is not available, a qualified electrician **MUST** install one before you can connect the machine to power.

A power supply circuit includes all electrical equipment between the breaker box or fuse panel in the building and the machine. The power supply circuit used for this machine must be sized to safely handle the full-load current drawn from the machine for an extended period of time. (If this machine is connected to a circuit protected by fuses, use a time delay fuse marked D.)

Full-Load Current Rating

The full-load current rating is the amperage a machine draws at 100% of the rated output power. On machines with multiple motors, this is the amperage drawn by the largest motor or sum of all motors and electrical devices that might operate at one time during normal operations.

Full-Load Current Rating (W1867) 15 Amps

Circuit Requirements

This machine is prewired to operate on a power supply circuit that has a verified ground and meets the following requirements:

Circuit Type 110V, 60 Hz, Single-Phase
 Circuit Size 20 Amps
 Plug/Receptacle NEMA 5-15

⚠️ WARNING

The machine must be properly set up before it is safe to operate. **DO NOT** connect this machine to the power source until instructed to do so later in this manual.

⚠️ WARNING



Incorrectly wiring or grounding this machine can cause electrocution, fire, or machine damage. To reduce this risk, only an electrician or qualified service personnel should do any required electrical work on this machine.

NOTICE

The circuit requirements listed in this manual apply to a dedicated circuit—where only one machine will be running at a time. If this machine will be connected to a shared circuit where multiple machines will be running at the same time, consult with an electrician to ensure that the circuit is properly sized for safe operation.

ELECTRICAL

Grounding Requirements

This machine **MUST** be grounded. In the event of certain types of malfunctions or breakdowns, grounding provides a path of least resistance for electric current to travel—in order to reduce the risk of electric shock.

Improper connection of the equipment-grounding wire will increase the risk of electric shock. The wire with green insulation (with/without yellow stripes) is the equipment-grounding wire. If repair or replacement of the power cord or plug is necessary, do not connect the equipment-grounding wire to a live (current carrying) terminal.

Check with a qualified electrician or service personnel if you do not understand these grounding requirements, or if you are in doubt about whether the tool is properly grounded. If you ever notice that a cord or plug is damaged or worn, disconnect it from power, and immediately replace it with a new one.

For 110V Connection

This machine is equipped with a power cord with an equipment-grounding wire and NEMA 5-15 grounding plug (see figure). The plug must only be inserted into a matching receptacle that is properly installed and grounded in accordance with local codes and ordinances.

Extension Cords

We do not recommend using an extension cord with this machine. Extension cords cause voltage drop, which may damage electrical components and shorten motor life. Voltage drop increases with longer extension cords and smaller gauge sizes (higher gauge numbers indicate smaller sizes).

Any extension cord used with this machine must contain a ground wire, match the required plug and receptacle, and meet the following requirements:

- Minimum Gauge Size 12 AWG
- Maximum Length (Shorter is Better) 50 ft.

⚠ WARNING

The machine must be properly set up before it is safe to operate. **DO NOT** connect this machine to the power source until instructed to do so later in this manual.

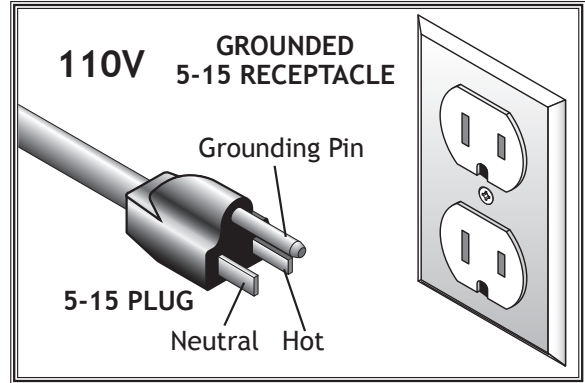

Figure 4. Typical 110V plug & receptacle.

⚠ CAUTION

No adapter should be used with the required plug. If the plug does not fit the available receptacle or the machine must be reconnected to a different type of circuit, the reconnection must be made by an electrician or qualified service personnel and it must comply with all local codes and ordinances.

ELECTRICAL

W1868/W1869 220V Circuit Requirements

This machine must be connected to the correct size and type of power supply circuit, or fire or electrical damage may occur. Read through this section to determine if an adequate power supply circuit is available. If a correct circuit is not available, a qualified electrician **MUST** install one before you can connect the machine to power.

A power supply circuit includes all electrical equipment between the breaker box or fuse panel in the building and the machine. The power supply circuit used for this machine must be sized to safely handle the full-load current drawn from the machine for an extended period of time. (If this machine is connected to a circuit protected by fuses, use a time delay fuse marked D.)

Full-Load Current Rating

The full-load current rating is the amperage a machine draws at 100% of the rated output power. On machines with multiple motors, this is the amperage drawn by the largest motor or sum of all motors and electrical devices that might operate at one time during normal operations.

Full-Load Current Rating (W1868) 9 Amps
 Full-Load Current Rating (W1869) 15 Amps

Circuit Requirements

This machine is prewired to operate on a power supply circuit that has a verified ground and meets the following requirements:

Circuit Type 220V, 60 Hz, Single-Phase
 Circuit Size (W1868) 15 Amps
 Circuit Size (W1869) 20 Amps
 Plug/Receptacle (W1868) NEMA 6-15
 Plug/Receptacle (W1869) NEMA 6-20

ELECTRICAL

⚠ WARNING

The machine must be properly set up before it is safe to operate. **DO NOT** connect this machine to the power source until instructed to do so later in this manual.

⚠ WARNING



Incorrectly wiring or grounding this machine can cause electrocution, fire, or machine damage. To reduce this risk, only an electrician or qualified service personnel should do any required electrical work on this machine.

NOTICE

The circuit requirements listed in this manual apply to a dedicated circuit—where only one machine will be running at a time. If this machine will be connected to a shared circuit where multiple machines will be running at the same time, consult with an electrician to ensure that the circuit is properly sized for safe operation.

Grounding Requirements

This machine **MUST** be grounded. In the event of certain types of malfunctions or breakdowns, grounding provides a path of least resistance for electric current to travel—in order to reduce the risk of electric shock.

Improper connection of the equipment-grounding wire will increase the risk of electric shock. The wire with green insulation (with/without yellow stripes) is the equipment-grounding wire. If repair or replacement of the power cord or plug is necessary, do not connect the equipment-grounding wire to a live (current carrying) terminal.

Check with a qualified electrician or service personnel if you do not understand these grounding requirements, or if you are in doubt about whether the tool is properly grounded. If you ever notice that a cord or plug is damaged or worn, disconnect it from power, and immediately replace it with a new one.

For 220V Connection

This machine is equipped with a power cord that has an equipment-grounding wire and NEMA 6-15 or 6-20 grounding plug. The plug must only be inserted into a matching receptacle (see **Figure**) that is properly installed and grounded in accordance with local codes and ordinances.

Extension Cords

We do not recommend using an extension cord with this machine. Extension cords cause voltage drop, which may damage electrical components and shorten motor life. Voltage drop increases with longer extension cords and smaller gauge sizes (higher gauge numbers indicate smaller sizes).

Any extension cord used with this machine must contain a ground wire, match the required plug and receptacle, and meet the following requirements:

- Minimum Gauge Size (W1868) 14 AWG
- Minimum Gauge Size (W1869) 12 AWG
- Maximum Length (Shorter is Better) 50 ft.

⚠ WARNING

The machine must be properly set up before it is safe to operate. **DO NOT** connect this machine to the power source until instructed to do so later in this manual.

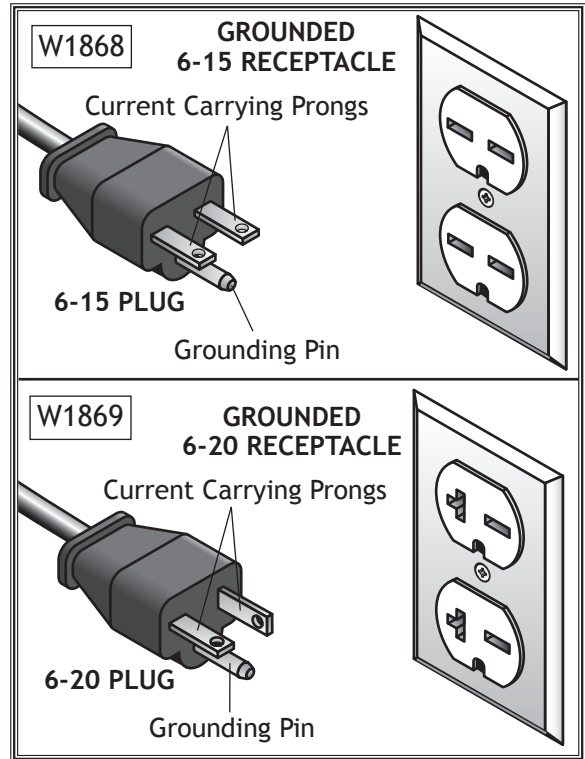

Figure 5. Typical 220V plugs & receptacles.

⚠ CAUTION

No adapter should be used with the required plug. If the plug does not fit the available receptacle or the machine must be reconnected to a different type of circuit, the reconnection must be made by an electrician or qualified service personnel and it must comply with all local codes and ordinances.

ELECTRICAL

SETUP

Unpacking

This machine has been carefully packaged for safe transportation. If you notice the machine has been damaged during shipping, please contact your authorized Shop Fox dealer immediately.

Items Needed for Setup

The following items are needed, but not included, to set up your machine.

Description	Qty
• Additional People.....	1
• Safety Glasses.....	1 ea.
• Wrench or Socket 10mm	1
• Wrench or Socket 12mm	1
• Wrench or Socket ⁵ / ₁₆ "	1
• Wrench or Socket ³ / ₈ "	1
• Wrench or Socket ¹ / ₂ "	1
• Hex Wrench 5mm.....	1
• Phillips Screwdriver #2	1

SETUP



!WARNING

This machine presents serious injury hazards to untrained users. Read through this entire manual to become familiar with the controls and operations before starting the machine!



!WARNING

Wear safety glasses during entire setup process!

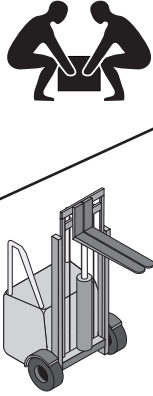

!WARNING

HEAVY LIFT!

Straining or crushing injury may occur from improperly lifting the machine or some of its parts. To reduce this risk, get help from other people and use a forklift (or other lifting equipment) rated for weight of machine.

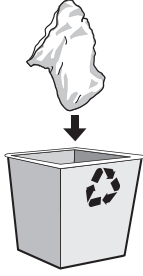

!WARNING

SUFFOCATION HAZARD!

Immediately discard all plastic bags and packing materials to eliminate choking/suffocation hazards for children and animals.

Inventory

The following is a list of items shipped with your machine. Before beginning setup, lay these items out and inventory them.

Note: If you cannot find an item on this list, carefully check around/inside the machine and packaging materials. Often, these items get lost in packaging materials while unpacking or they are pre-installed at the factory.

Boxed Inventory (Figure 6)	Qty
A. Intake Barrel	1
B. Impeller Housing.....	1
C. Cyclone Funnel.....	1
D. Drum Lock Handle.....	1
E. Collection Drum Lid w/Ground Wire	1
F. Control Box w/RF Receiver Unit & Remote Control .	1
G. Base.....	1
H. Hose Clamps 1 ³ / ₄ "	2
I. Collection Drum Latches	2
J. Vacuum Hose 1 ¹ / ₂ " x 60"	1
K. Filter Paddle Cover.....	1
L. Collection Drum Hose.....	1
M. Collection Drum Dust Bag	1
N. Filter Dust Bag	1
O. Swivel Casters 2"	4
P. Locking Swivel Casters 2 ¹ / ₂ "	4
Q. Flex Hose Clamps.....	2
R. Filter Dust Bag Clamp.....	1
S. Filter Handle Spindle	1
T. Collection Drum Handle	1
U. Inlet Adapter (W1867 Adapter Shown)	1
V. Support Legs.....	2
W. Lock Handle Guides	2
X. Dust Collection Drum	1
Y. Canister Filter.....	1
Z. Vacuum Ring.....	1
AA. Filter Cleaning Handle.....	1

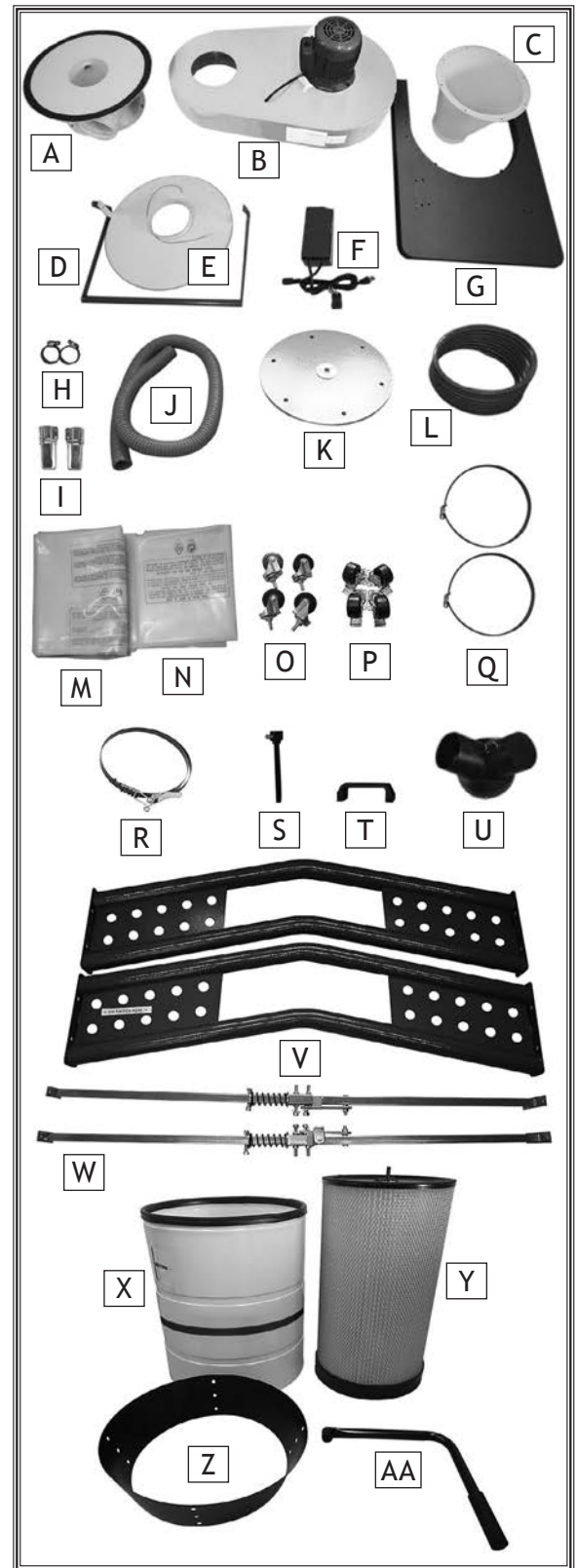

Figure 6. Boxed parts inventory.

SETUP

Hardware/Fasteners (Figure 7)	Qty
AB. Flange Bolts $\frac{5}{16}$ "-18 x $\frac{3}{4}$ ".....	28
AC. Flange Bolts $\frac{5}{16}$ "-18 x $\frac{1}{2}$ ".....	24
AD. Button Head Cap Screws $\frac{5}{16}$ "-18 x $\frac{3}{4}$ "	16
AE. Hex Nuts $\frac{5}{16}$ "-18.....	4
AF. Flange Nuts $\frac{5}{16}$ "-18	12
AG. Flange Screw 10-24 x $\frac{3}{8}$ "	1
AH. Phillips Head Screws 10-24 x $\frac{3}{4}$ "	2
AI. Phillips Head Screws $\frac{1}{4}$ "-20 x $\frac{5}{8}$ "	2
AJ. Phillips Head Screws M4-.7 x 8.....	8
AK. Fender Washers $\frac{5}{16}$ "	16
AL. Flat Washers $\frac{5}{16}$ "	4
AM. Lock Nuts M4-.7.....	8
AN. Hex Nuts 10-24.....	2
AO. Acorn Nuts $\frac{1}{4}$ "-20	2

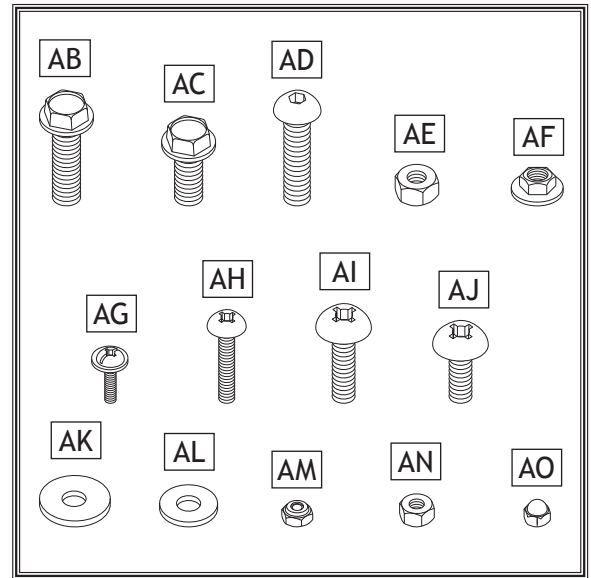

Figure 7. Hardware/fasteners.

Machine Placement

Weight Load

Refer to the **Machine Specifications** for the weight of your machine. Make sure that the surface upon which the machine is placed will bear the weight of the machine, additional equipment that may be installed on the machine, and the heaviest workpiece that will be used. Additionally, consider the weight of the operator and any dynamic loading that may occur when operating the machine.

Space Allocation

Consider the largest size of workpiece that will be processed through this machine and provide enough space around the machine for adequate operator material handling or the installation of auxiliary equipment. With permanent installations, leave enough space around the machine to open or remove doors/covers as required by the maintenance and service described in this manual. **See below for required space allocation.**

Physical Environment

The physical environment where your machine is operated is important for safe operation and the longevity of its components. For best results, operate this machine in a dry environment that is free from excessive moisture, hazardous chemicals, airborne abrasives, or extreme conditions. Extreme conditions for this type of machinery are generally those where the ambient temperature range exceeds 41°-104°F; the relative humidity range exceeds 20-95% (non-condensing); or the environment is subject to vibration, shocks, or bumps.

Electrical Installation

Place this machine near an existing power source. Make sure all power cords are protected from traffic, material handling, moisture, chemicals, or other hazards. Make sure to leave access to a means of disconnecting the power source or engaging a lockout/tagout device.

Lighting

Lighting around the machine must be adequate enough that operations can be performed safely. Shadows, glare, or strobe effects that may distract or impede the operator must be eliminated.

SETUP

	<p>⚠ CAUTION</p> <p>Children or untrained people may be seriously injured by this machine. Only install in an access restricted location.</p>
--	--

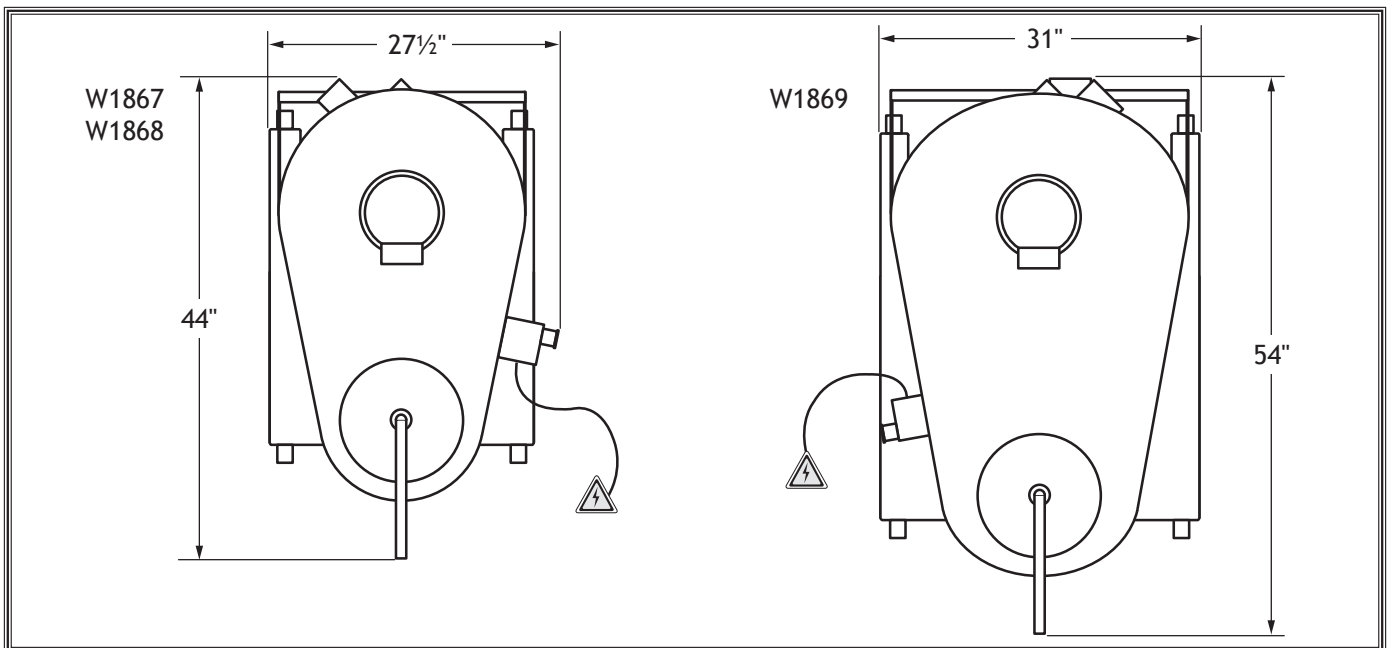

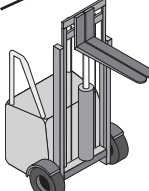

Figure 8. Working clearances.

Assembly

Before beginning the assembly process, refer to **Items Needed for Setup** and gather everything you need. Ensure all parts have been properly cleaned of any heavy-duty rust-preventative applied at the factory (if applicable). Be sure to complete all steps in the assembly procedure prior to performing the **Test Run**.

⚠ WARNING
HEAVY LIFT!
 Straining or crushing injury may occur from improperly lifting the machine or some of its parts. To reduce this risk, get help from other people and use a forklift (or other lifting equipment) rated for weight of machine.

IMPORTANT: When assembling any components with a gasket, tighten fasteners in an alternating star pattern to ensure an even seal and reduce the risk of air leaks (see **Figure 9**).

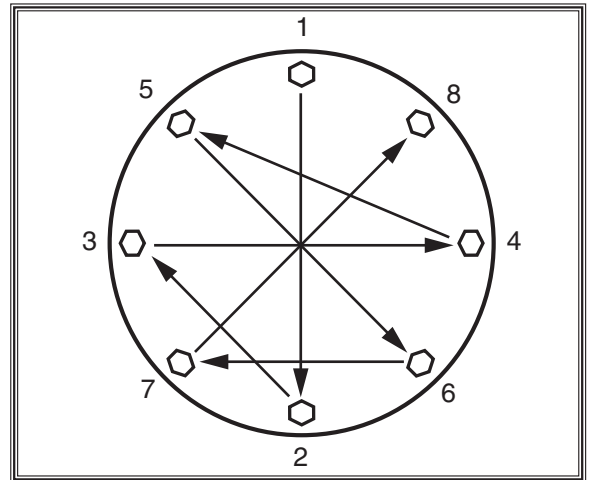

Figure 9. Alternating star pattern for tightening fasteners of components assembled with a gasket.

To assemble dust collector, do these steps:

1. Attach (4) 2 1/2" locking swivel casters to bottom of base, and secure each caster with (4) 5/16"-18 x 1 1/2" flange bolts (see **Figure 10**).

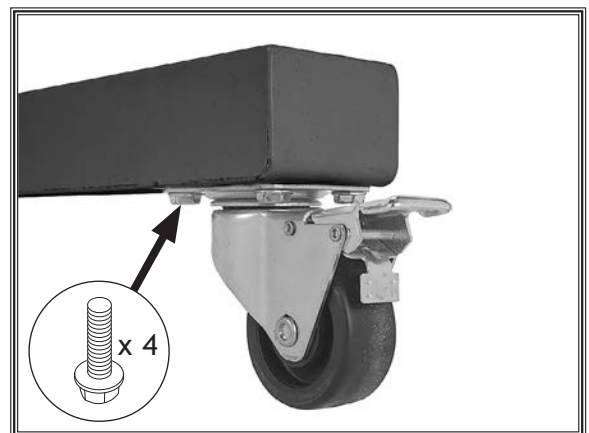

Figure 10. Locking swivel caster (1 of 4) attached to base.

SETUP

- Attach each support leg to base, as shown in **Figure 11**, and finger-tighten with (8) $\frac{5}{16}$ "-18 x $\frac{3}{4}$ " button head cap screws and (8) $\frac{5}{16}$ " fender washers.

Note: For Models W1867 and W1868, install support leg with **FIX SWITCH HERE** sticker on left side of base. For Model W1869, install support leg with **FIX SWITCH HERE** sticker on right side of base.

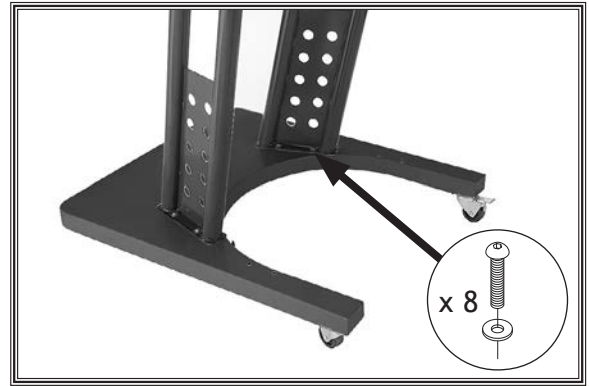

Figure 11. Support legs attached to base.

- Attach lock handle guide with stop plate to left side of base stand, and finger-tighten with (2) $\frac{5}{16}$ "-18 x $\frac{1}{2}$ " flange bolts (see **Figure 12**).
- Repeat **Step 3** to attach second lock handle guide to right side of base.

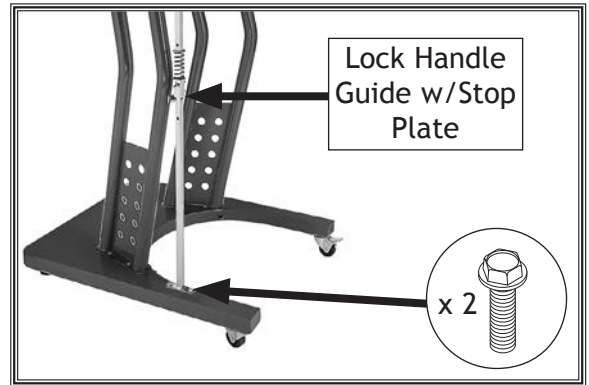

Figure 12. Lock handle guide with stop plate attached to base.

⚠ CAUTION

Once installed, the impeller housing makes the machine top heavy. Assistants must securely hold the impeller housing in place until Steps 5-7 are completed.

- With help of two assistants, lift impeller housing and onto support legs and lock handle guides (see **Figure 13**).

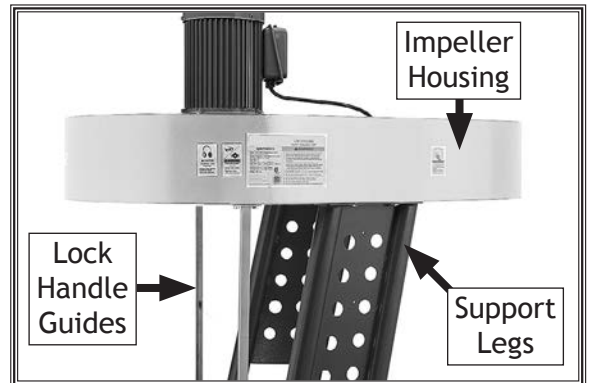

Figure 13. Impeller housing positioned on support legs and lock handle guides.

- Secure impeller housing to support legs with (8) $\frac{5}{16}$ "-18 x $\frac{3}{4}$ " button head cap screws and (8) $\frac{5}{16}$ " fender washers (see **Figure 14**).
- Secure impeller housing to lock handle guides with (4) $\frac{5}{16}$ "-18 x $\frac{1}{2}$ " flange bolts (see **Figure 14**).
- Fully tighten all fasteners installed in **Steps 2-4** (see **Figures 11-12**).

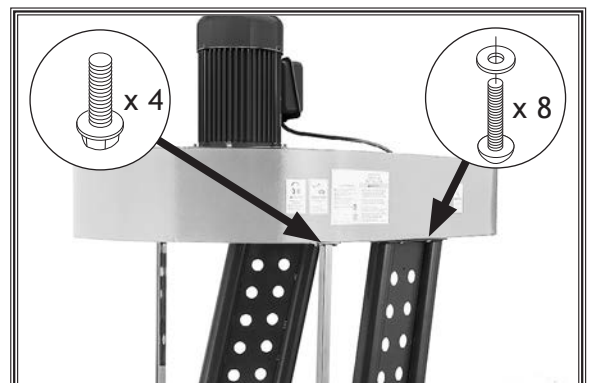

Figure 14. Impeller housing attached to support legs and lock handle guides.

SETUP

8. Fully tighten all fasteners installed in Steps 2-4 (see Figures 11-12).
9. Have an assistant align intake barrel so dust port points straight out from impeller housing (see Figure 15), then attach to impeller housing with (8) $\frac{5}{16}$ "-18 x $\frac{1}{2}$ " flange bolts.

Note: For W1867 and W1868, align dust port on right. For W1869, align dust port on left.

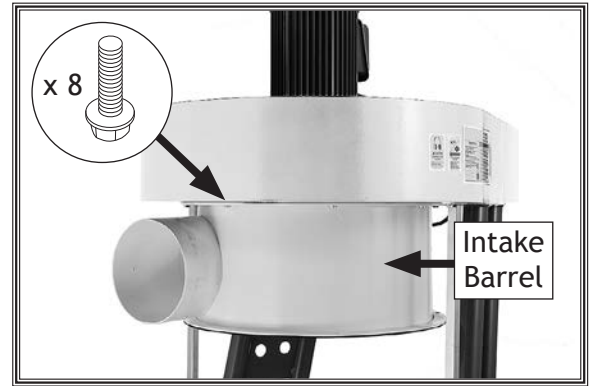

Figure 15. Intake barrel attached to impeller housing.

10. Attach cyclone funnel to intake barrel, as shown in Figure 16, using (8) $\frac{5}{16}$ "-18 x $\frac{3}{4}$ " flange bolts and (8) $\frac{5}{16}$ "-18 hex nuts.

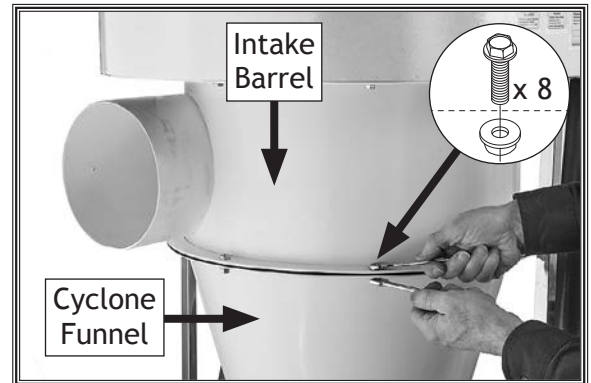

Figure 16. Attaching cyclone funnel to intake barrel.

11. Using fasteners attached to spring bracket, place upper end of drum lock handle over outer stud on spring bracket, then attach lock handle link to lower hole on lock handle (see Figure 17).

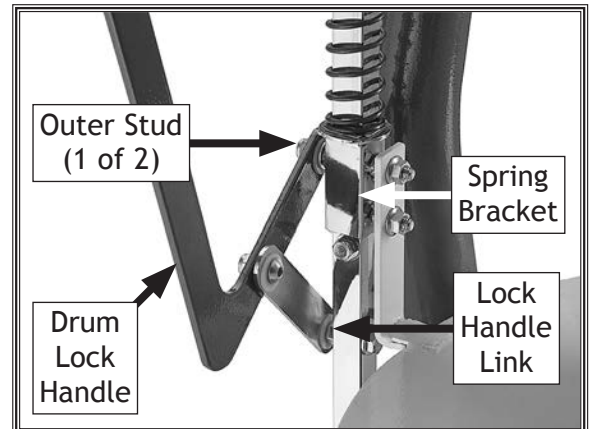

Figure 17. Lock handle attached to spring bracket and lock handle link.

12. Place (2) hose clamps around flexible hose, then slide hose over port on collection drum lid and tighten clamp (see **Figure 18**).
13. With collection drum lid mounting brackets facing up, orient lid so dust port, flexible hose, and spring brackets align (see **Figure 18**).
14. Attach flexible hose to cyclone funnel and secure with (1) hose clamp (see **Figure 18**).
15. Connect ground wire to spring bracket stud, then secure lid and ground wire using (4) $\frac{5}{16}$ "-18 flange nuts (see **Figure 18**).

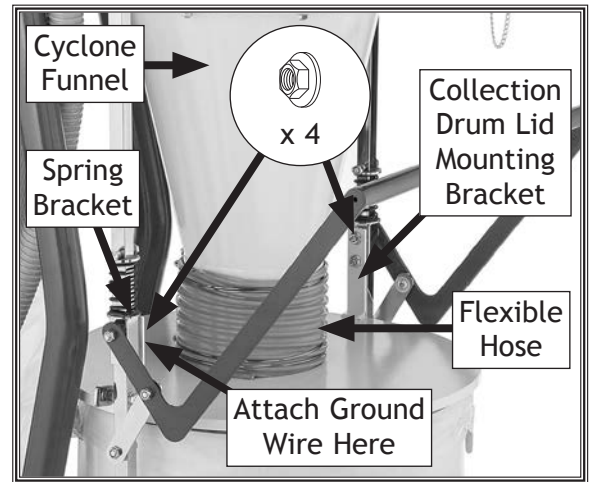

Figure 18. Collection drum lid and related components installed.

16. Attach 2" swivel casters to collection drum, as shown in **Figure 19**, using (1) $\frac{5}{16}$ "-18 hex nut on each.
17. Adjust pre-installed flange nut and hex nut (see **Figure 19**) until drum rolls evenly without rocking or wobbling, then tighten both nuts to secure caster in place.

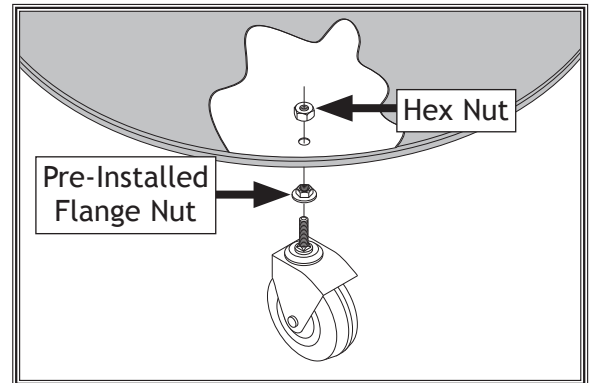

Figure 19. Cut-away illustration of 2" swivel caster attachment to collection drum.

18. Place vacuum ring inside collection drum with smaller side of ring facing down, as shown in **Figure 20**.

Note: During operation, this ring and the vacuum connection to the cyclone funnel will prevent the collection bag from collapsing or being pulled up into the cyclone.

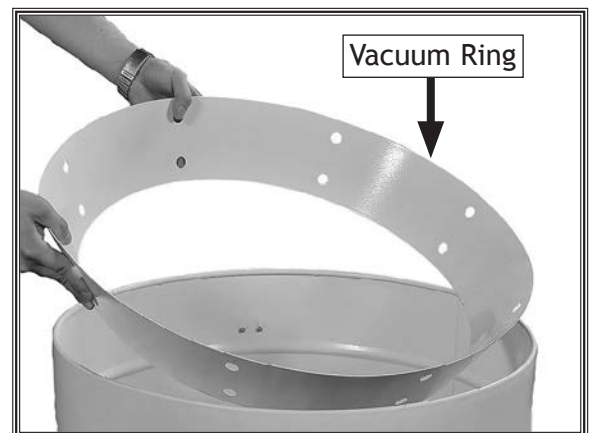

Figure 20. Inserting vacuum ring into collection drum.

SETUP

19. Attach both drum latches using (4) M4-.7 x 8 Phillips head screws and (4) M4-.7 lock nuts per latch (see Figure 21).

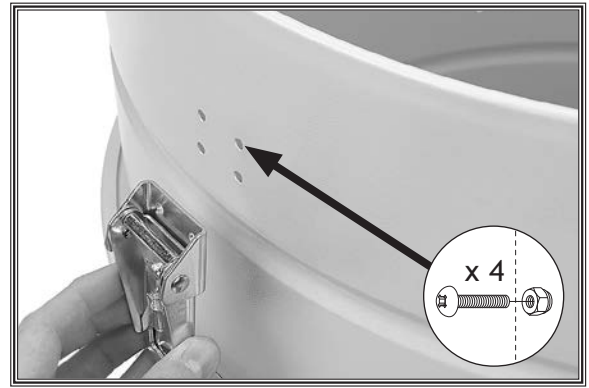

Figure 21. Attaching latch to collector drum.

20. Attach handle to collection drum using (2) 1/4"-20 x 5/8" Phillips head screws and (2) 1/4"-20 acorn nuts (see Figure 22).

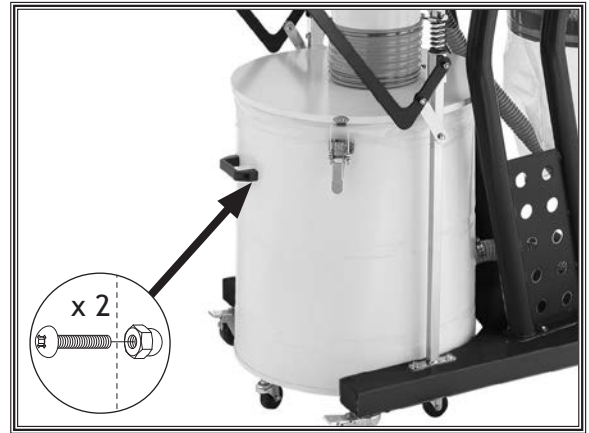

Figure 22. Collection drum handle attached.

21. Insert large plastic dust bag inside collection drum, and fold excess length of bag over top of collection drum.

22. Move collection drum under lid, connect latches to lid hooks, then secure latches.

23. Press drum lock handle down to lift collection drum off floor.

24. Place 1 3/4" hose clamps on each end of 1 1/2" x 60" vacuum hose, then connect hose to ports on cyclone funnel and collection drum (see Figure 23).

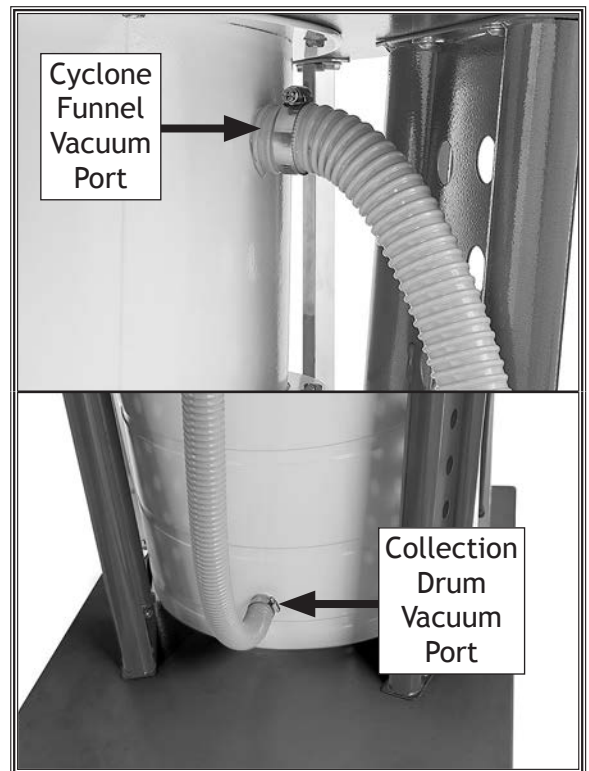

Figure 23. Vacuum hose connections.

25. While assistant holds canister filter under impeller housing, reach into impeller housing and attach canister filter to impeller housing with (6) $\frac{5}{16}$ "-18 x $\frac{1}{2}$ " flange bolts (see **Figure 24**).

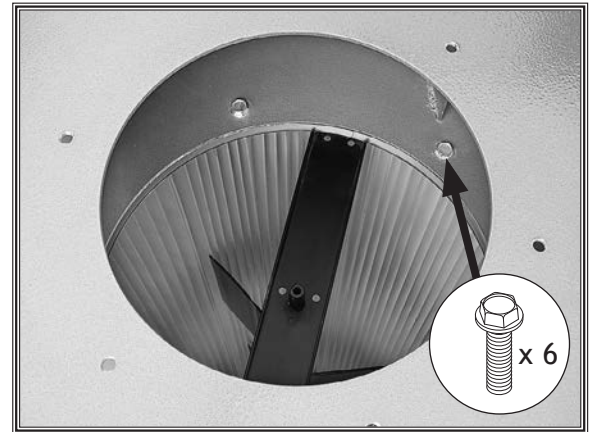

Figure 24. Canister filter attached to impeller housing.

26. Insert filter handle spindle so one of two M6-1 x 16 cap screw tips aligns with flat on side of filter paddle spindle, then tighten both cap screws to secure spindle (see **Figure 25**).

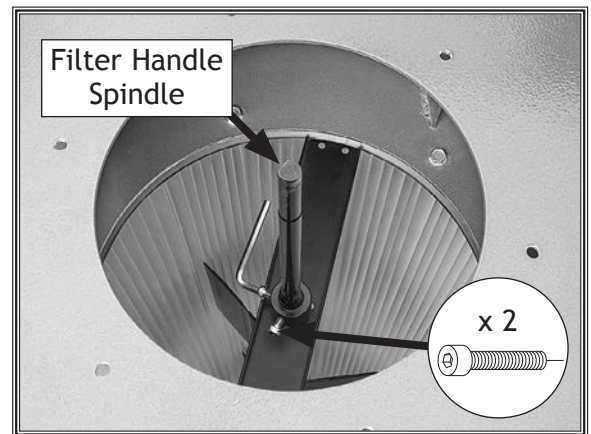

Figure 25. Filter handle spindle attached to canister filter assembly.

27. Slide filter paddle cover over filter handle spindle, then secure with (6) $\frac{5}{16}$ "-18 x $\frac{3}{4}$ " flange bolts (see **Figure 26**).

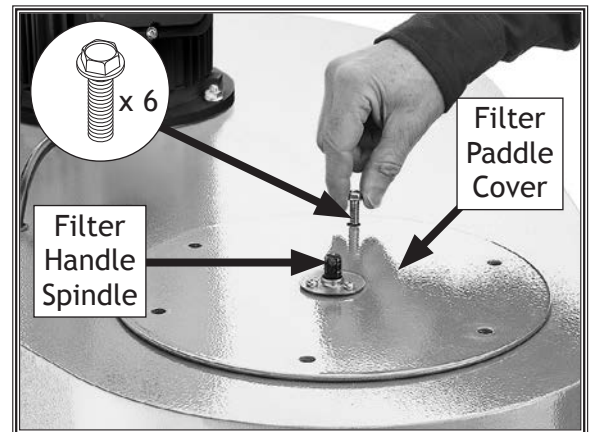

Figure 26. Installing filter paddle cover.

SETUP

28. Install filter cleaning handle on spindle so that M6-1 x 16 hex bolt tip aligns with spindle flat, then tighten hex bolt (see **Figure 27**).

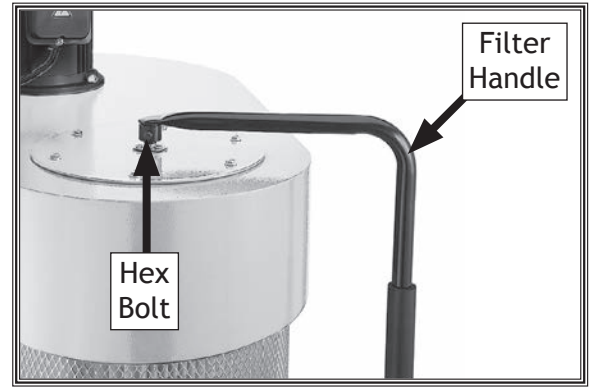

Figure 27. Filter handle installed on spindle.

29. Attach plastic filter bag to canister filter and secure with bag clamp (see **Figure 28**).

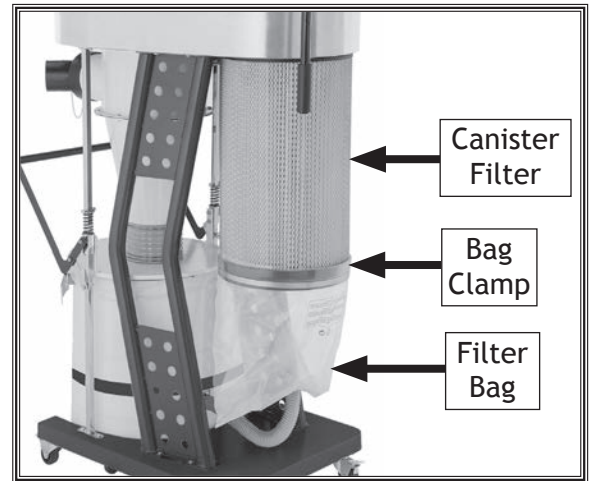

Figure 28. Filter bag attached to canister filter.

30. Loosen (2) Phillips head screws and remove magnetic switch cover (see **Figure 29**).

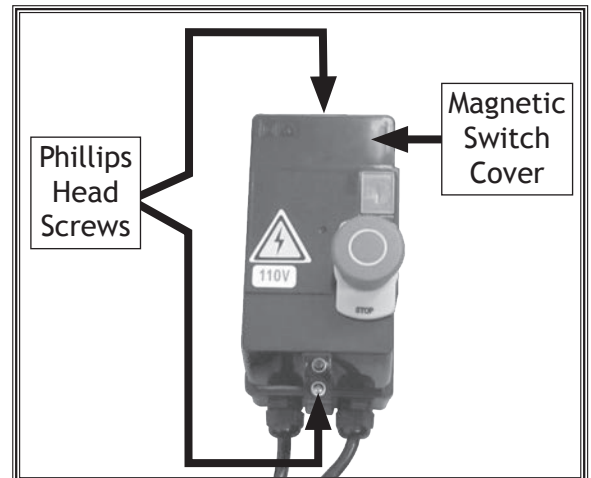

Figure 29. Magnetic switch cover.

SETUP

- 31. Install magnetic switch over FIX SWITCH HERE label (left support arm for Models W1867 and W1868, right support arm for Model W1869), then secure with (2) 10-24 x 3/4" Phillips head screws and (2) 10-24 hex nuts (see Figure 30).

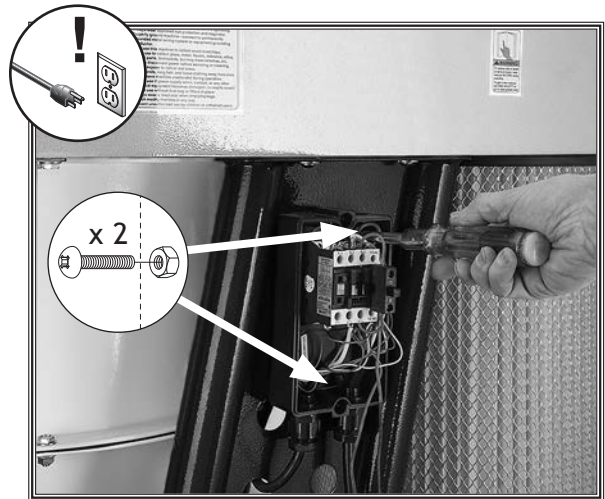

Figure 30. Installing magnetic switch on support arm.

- 32. Tuck loose wires into magnetic switch cover so none can be crimped when cover is re-attached, and then replace magnetic switch cover and tighten (2) Phillips head screws loosened in Step 30 to secure.
- 33. Thread motor cord through support arm opening and connect to matching plug from motor under impeller housing (see Figure 31).

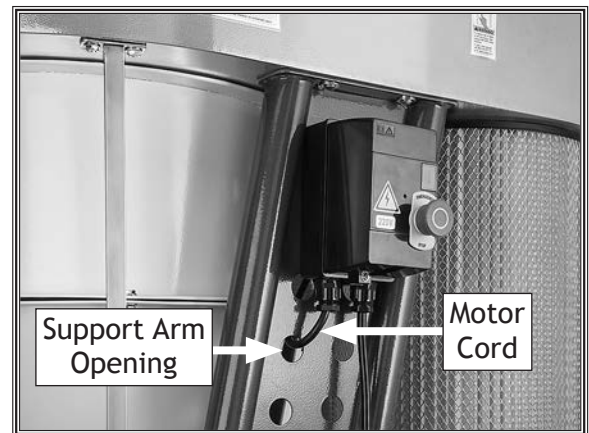

Figure 31. Magnetic switch attached to support arm.

- 34. Install inlet adapter on dust port and secure with 10-24 x 3/8" flange screw (see Figure 32).

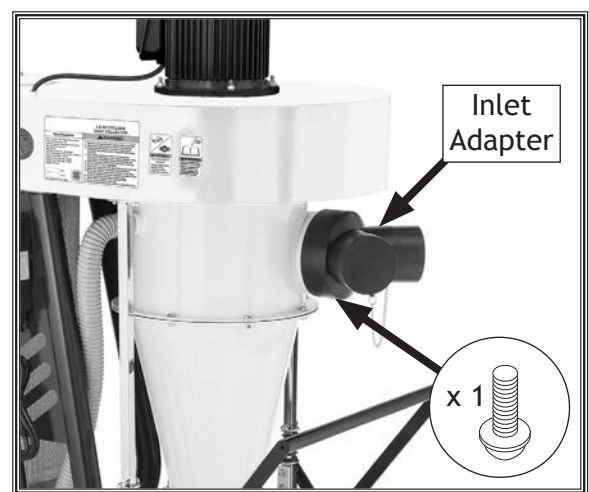

Figure 32. Inlet adapter installed on dust port.

SETUP

Test Run

Once assembly is complete, test run the machine to ensure it is properly connected to power and safety components are functioning properly.

If you find an unusual problem during the test run, immediately stop the machine, disconnect it from power, and fix the problem **BEFORE** operating the machine again. The **Troubleshooting** table in the **SERVICE** section of this manual can help.

To test run machine, do these steps:

1. Clear all setup tools away from machine.
2. Lock all swivel casters on base stand.
3. Connect machine to dust-collection system or place covers over inlet adapter ports.

IMPORTANT: DO NOT operate dust collector without first connecting it to a dust-collection system or covering an inlet adapter port. Otherwise the lack of airflow resistance will cause the motor to operate at full amperage load, which could trip your circuit breaker or blow a fuse.

4. Press Emergency Stop button in, and connect machine to power.
5. Twist Emergency Stop button clockwise until it springs out (see **Figure 33**). This resets switch so machine can start.
6. Standing away from intake port, press green "I" button to turn machine **ON**. Verify motor starts up and runs smoothly without any problems or unusual noises.
7. Press Emergency Stop button to turn machine **OFF**.
8. **WITHOUT** resetting Emergency Stop button, try to start machine by pressing the "I" button. The machine should **NOT** start.
 - If machine *does not* start, the Emergency Stop button is working correctly.
 - If machine *does* start, immediately turn it **OFF** and disconnect power. The Emergency Stop button is **NOT** working properly and must be corrected before further using the machine.

⚠ WARNING

Serious injury or death can result from using this machine **BEFORE** understanding its controls and related safety information. **DO NOT** operate, or allow others to operate, machine until the information is understood.

⚠ WARNING

DO NOT start machine until all preceding setup instructions have been performed. Operating an improperly set up machine may result in malfunction or unexpected results that can lead to serious injury, death, or machine/property damage.

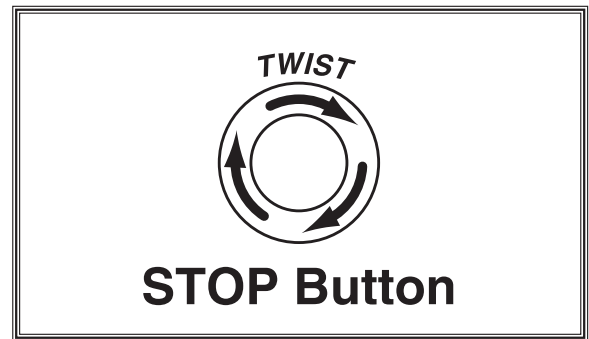

Figure 33. Resetting Emergency Stop button.

9. To test remote control operation, press green remote button to turn motor **ON**. The motor should run smoothly with little or no vibration or rubbing noises.
10. Press red remote button to turn motor **OFF**.
 - If the machine does not shut off with the remote control, press the Emergency Stop button to turn machine **OFF**. Refer to **Troubleshooting** on **Page 43** to correct any problems with the remote control unit before further using it again with the machine.

SETUP

DESIGNING THE SYSTEM

General

⚠ CAUTION

Always make sure there are no open flames or pilot lights in the same room as the dust collector. There is a risk of explosion if too much fine dust is dispersed into the air with an open flame present.



⚠ CAUTION

Always guard against static electrical build up by grounding all dust collection lines.

The Model W1867/W1868/W1869 works quite well as a point-of-use dust collector, or for collecting dust from up to two machines (Model W1867) or up to three machines (Models W1868 and W1869) simultaneously. The locking swivel casters make it easy to move around the shop near the machine being used.

Tips for Optimum Performance

- Avoid using more than 10' of flexible hose on any ducting line. The ridges inside flexible house greatly increase pressure loss, which reduces suction performance.
- Keep ducts between the dust collector and machines as short as possible.
- Keep ducting directional changes to a minimum. The more curved fittings you use, the greater the loss of suction at the dust-producing machine.
- Gradual directional changes are more efficient than sudden directional changes (i.e. use 45° elbows in place of 90° elbows whenever possible).
- The simpler the system, the more efficient and less costly it will be.

Duct Material

You have many choices regarding main line and branch line duct material. For best results, use smooth metal duct for the main line and branch lines, then use short lengths of flexible hose to connect each machine to the branch lines.

Plastic duct is also a popular material for home shops. However, be aware that there is a fire or explosion hazard if plastic duct material is not properly grounded to prevent static electrical build-up. (Refer to **System Grounding** later in this section.) Another problem with using plastic is that it is less efficient per foot than metal.



⚠ CAUTION

Plastic duct generates static electrical buildup that can cause fire or shock. Properly ground it to reduce this risk.

Plastic Duct

The popularity of plastic duct is due to the fact that it is an economical and readily available product. It is also simple to assemble and easily sealed against air loss. The primary disadvantage of plastic duct for dust collection is the inherent danger of static electrical build-up.



Figure 34. Examples of plastic ducting components.

SETUP

Metal Duct

Advantages of smooth metal duct is its conductivity, efficiency, and that it does not contribute to static electrical charge build-up. However, static charges are still produced when dust particles strike other dust particles as they move through the duct. Since metal duct is a conductor, it can be grounded quite easily to dissipate any static electrical charges.

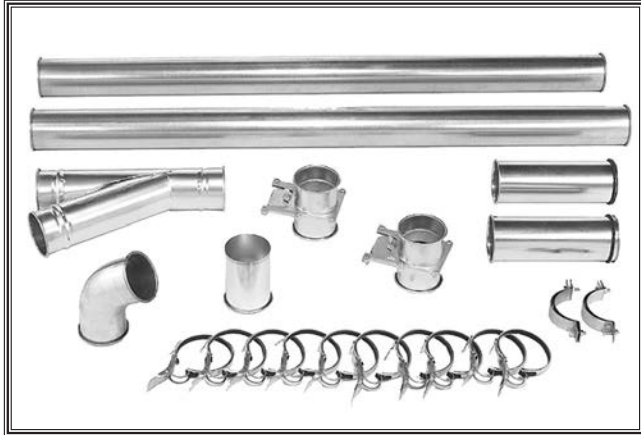

Figure 35. Examples of smooth metal duct and components.

There are a number of options when it comes to metal duct, but metal duct that is specially manufactured for dust collection is the best choice. When selecting your metal duct, choose high quality metal duct with smooth welded internal seams that will minimize airflow resistance. This type of duct usually connects to other ducts or elbows with a simple, self-sealing clamp, is very quick and easy to assemble, and can be readily dismantled and re-installed in a different configuration. This is especially important if you ever need to change things around in your shop or add more tools.

Avoid inferior metal duct that requires you to cut it to length and snap it together. This type of duct is time consuming to install because it requires you to seal all the seams with silicone and screw the components on the ends with sheet metal screws. Another disadvantage is the rough internal seams and crimped ends that unavoidably increase static pressure loss.

Flexible Duct

Flexible hose is generally used for short runs, small shops and at rigid duct-to-tool connections. There are many different types of flex hose on the market today. These are manufactured from materials such as polyethylene, PVC, cloth hose dipped in rubber and even metal, including steel and aluminum.

The superior choice here is metal flex hose that is designed to be flexible, yet be as smooth as possible inside to reduce static pressure loss.

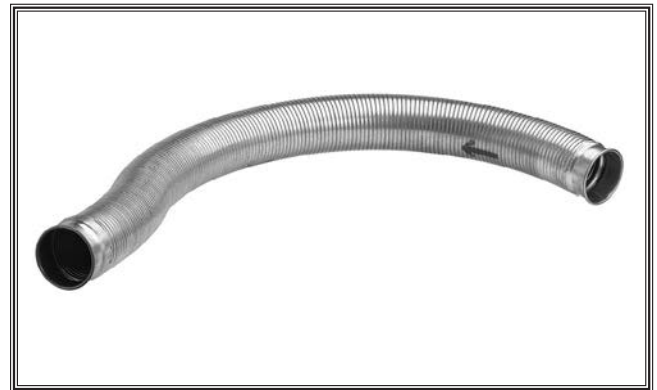

Figure 36. Example of flexible metal duct.

There are also many kinds of pure plastic flexible hose, such as non-perforated drainage type hose and dryer vent hose. Drainage type hose, while being economical, does not quite have the flexibility required for dust collection. The inside of the duct is also deeply corrugated and can increase the static pressure loss by as much as 50% over smooth wall duct. Dryer vent hose, while being completely flexible, is non-resistant to abrasion and has a tendency to collapse in a negative pressure system. We DO NOT recommend using dryer vent hose in your dust collection system.

If using flex-hose, you should choose one of the many types that are designed specifically for the movement of solid particles, i.e. dust, grains, and plastics. However, the cost of specifically designed flexible duct can vary greatly. Grizzly offers polyethylene hose, which is well suited for the removal of particulate matter, especially sawdust, since it is durable and completely flexible. Polyethylene is also very economical and available in a wide variety of diameters and lengths for most applications.

System Design

Decide Who Will Design

For most small-to-medium sized shops, you can design and build the dust collection system yourself without hiring engineers or consultants. We have included some basic information here to get you started on a basic design.

If you have a large shop or plan to design a complicated system, we recommend doing additional research beyond this manual or seeking the help of an expert.

Sketch Your Shop Layout

When designing a successful dust collection system, planning is the most important step. In this step, sketch a basic layout of your shop, including space requirements of different machines.

Your sketch only needs the basic details of the shop layout, similar to the figure below, including all your current/planned machines and your planned placement of the dust collector.

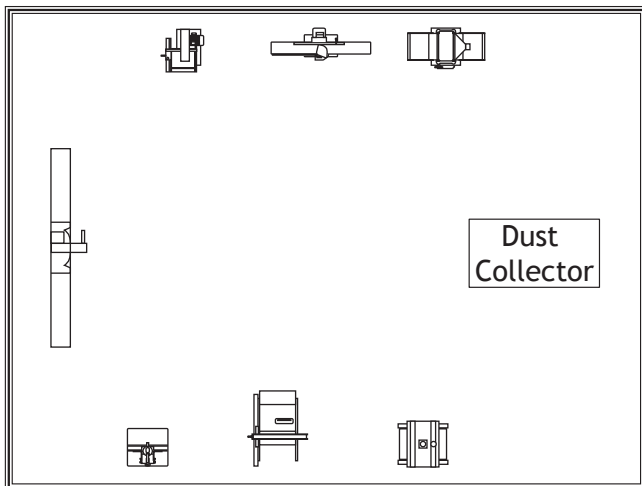

Figure 37. Basic sketch of shop layout.

Sketch a Basic Duct Layout

For the next step, sketch how you will connect your machines to the dust collector. Consider these general guidelines for an efficient system:

1. Machines that produce the most saw dust should be placed nearest to the dust collector (i.e. planers and sanders).
2. Ideally, you should design the duct system to have the shortest possible main line and secondary branch ducts. See the figures below for ideas of efficient versus inefficient duct layouts.

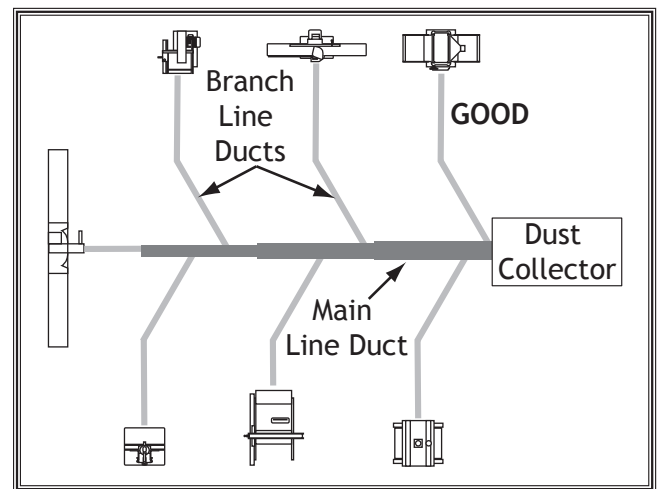

Figure 38. Efficient duct layout.

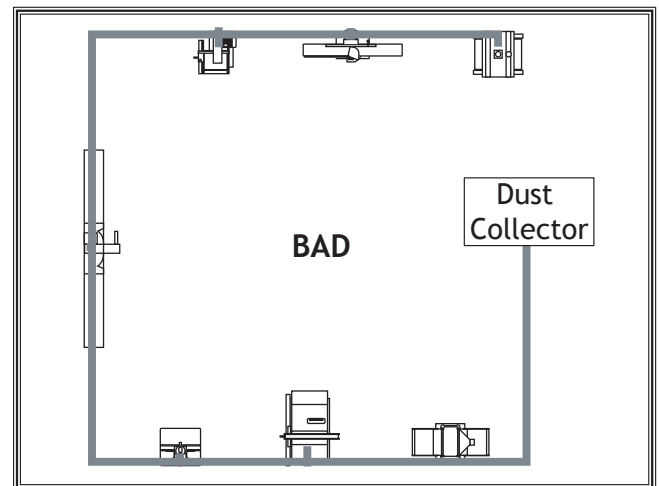

Figure 39. Inefficient duct layout.

SETUP

3. Directional changes should be kept to a minimum. The more directional change fittings you use directly increases the overall resistance to airflow.
4. Gradual directional changes are more efficient than sudden directional changes (i.e. use the largest corner radius possible when changing hose or pipe direction).
5. Each individual branch line should have a blast gate immediately after the branch to control suction from one machine to another.
6. The simpler the system, the more efficient and less costly it will be.

Determine Required CFMs

Since each machine produces a different amount of sawdust, the requirements for the minimum amount of CFM to move that sawdust is unique to the machine (for example, a planer produces more sawdust than a table saw). Knowing this required CFM is important to gauging which size of duct to use.

Refer to the figure below for a close estimation of the airflow each machine requires. Keep in mind that machines that generate the most sawdust should be placed closest to the dust collector. If the machine has multiple dust ports, the total CFM required is the sum of all ports.

Machine Dust Port Size	Approximate Required CFM
2"	100
2.5"	150
3"	250
4"	400
5"	600
6"	850
7"	1200
8"	1600
9"	2000
10"	2500

Figure 40. Approximate required air flow for machines, based on dust port size.

If the machine does not have a built-in dust port, use the following table to determine which size of dust port to install.

Machine	Average Dust Port Size
Table Saw	4"
Miter/Radial-Arm Saw	2"
Jointer (6" and smaller)	4"
Jointer (8"-12")	5"
Thickness Planer (13" and smaller)	4"
Thickness Planer (14"-20")	6"
Shaper	4"
Router (mounted to table)	2"
Bandsaw	4"
Lathe	4"
Disc Sander (12" and smaller)	2"
Disc Sander (13-18")	4"
Belt Sander (6" and smaller)	2"
Belt Sander (7"-9")	3"
Edge Sander (6" x 80" and smaller)	4"
Edge Sander (6" x 80" and larger)	5"
Drum Sander (24" and smaller)	2 x 4"
Drum Sander (24" and larger)	4 x 4"
Widebelt Sander (18" and smaller)	5"
Widebelt Sander (24"-37" single head)	.2 x 6"
Widebelt Sander (24"-51" double head)	.5 x 4"

Figure 41. Dust port size and quantity per average machine.

Write the required CFM for each machine on your sketch, as shown in the Figure below.

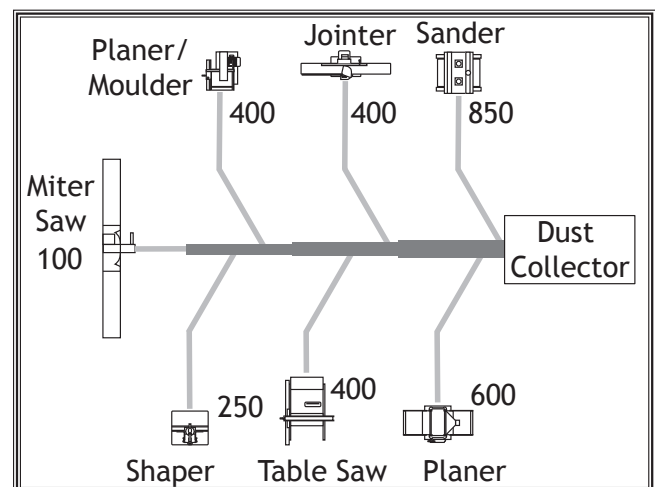

Figure 42. CFM requirements labeled for each machine.

Determining Main Line Duct Size

The general rule of thumb for a main line duct is that the velocity of the airflow must not fall below 3500 FPM.

For small/medium sized shops, using the inlet size of the dust collector as the main line duct size will usually keep the air velocity above 3500 FPM and, depending on your system, will allow you to keep multiple branches open at one time.

Mark your drawing, as shown in the figure below, but using the inlet size for your dust collector as the main line.

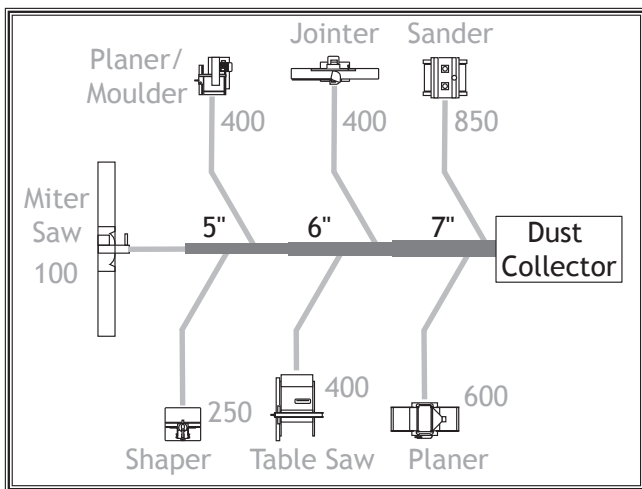

Figure 43. Main line size labeled on sketch.

Determining Branch Line Duct Size

The general rule of thumb for a branch line duct is that the velocity of the airflow must not fall below 4000 FPM.

For small/medium sized shops, using the dust port size from the machine as the branch line duct size will achieve the correct velocity in most applications. However, if the dust port on the machine is smaller than 4", make the branch line 4" and neck the line down right before the dust port.

Note: Systems with powerful dust collectors work better if multiple blast gates are left open. This also allows you to run two machines at once. Experiment with different combinations of blast gates open/closed to find the best results for your system.

Write your determined branch line sizes on your drawing, as shown in the following figure.

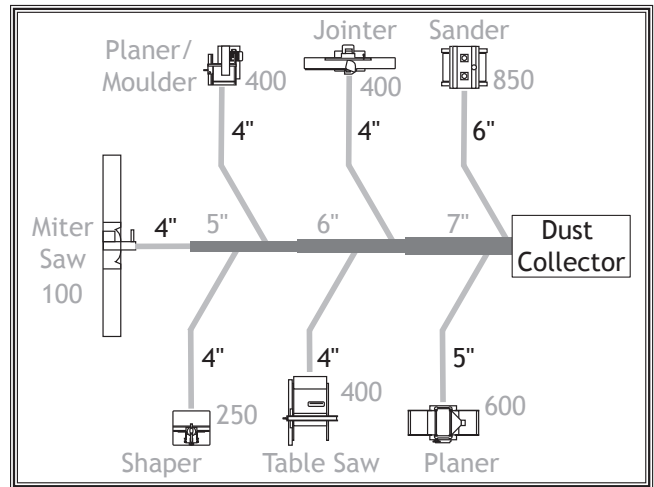

Figure 44. Branch line duct sizes labeled.

If two machines will connect to the same branch line and both will operate at the same time, then add the required CFM for each machine together and find the closest total CFM in the table below to determine the correct branch size.

If both machines will never run at the same time, reference the machine with the biggest dust port in the table below and add blast gates after the Y-branch to open/close the line to each machine.

Total CFM	Branch Line Size
400	4"
500	4"
600	5"
700	5"
800	6"
900	6"
1000	6"

Figure 45. Sizing chart for multiple machines on the same branch line.

SETUP

Planning Drop Downs

Plan the drop downs for each machine, using blast gates wherever possible to control airflow.

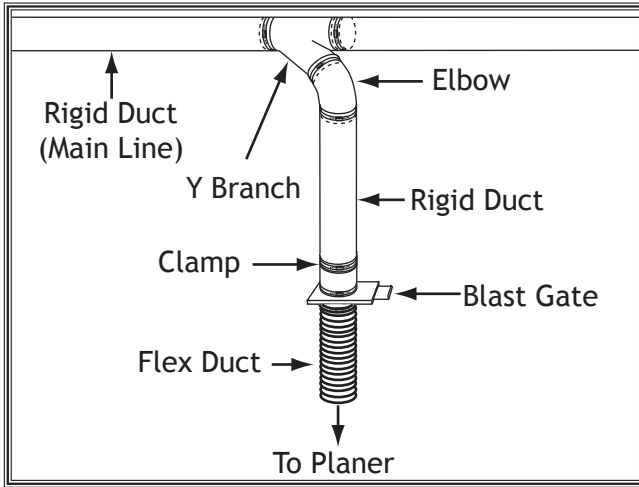

Figure 46. Drop down setup.

Calculating Duct Resistance

Adding duct work, elbows, branches and any other components to a duct line increases airflow resistance (static pressure loss). This resistance can be minimized by using rigid (smooth) duct and gradual curves, as opposed to flexible duct and 90° elbows.

To help you think about this resistance, imagine riding a bicycle in a tunnel that is an exact replica of your duct work. If the inside of the tunnel is very bumpy (flexible duct) and has a lot of sharp turns (90° elbows), it will take a lot more effort to travel from one end to the other.

The purpose of calculating the resistance is to determine if it is low enough from the machine to the dust collector to meet the given CFM requirement for the machine. Use the following tables to calculate the resistance of duct work.

Duct Dia.	Approximate Static Pressure Loss Per Foot of Rigid Duct		Approximate Static Pressure Loss Per Foot of Flex Duct	
	Main Lines at 3500 FPM	Branch Lines at 4000 FPM	Main Lines at 3500 FPM	Branch Lines at 4000 FPM
2"	0.091	0.122	0.35	0.453
2.5"	0.08	0.107	0.306	0.397
3"	0.071	0.094	0.271	0.352
4"	0.057	0.075	0.215	0.28
5"	0.046	0.059	0.172	0.225
6"	0.037	0.047	0.136	0.18
7"	0.029	0.036	0.106	0.141
8"	0.023	0.027	0.08	0.108
9"	0.017	0.019	0.057	0.079

Fitting Dia.	90° Elbow	45° Elbow	45° Wye(Y)	90° Wye(Y)
3"	0.47	0.235	0.282	0.188
4"	0.45	0.225	0.375	0.225
5"	0.531	0.266	0.354	0.236
6"	0.564	0.282	0.329	0.235
7"	0.468	0.234	0.324	0.216
8"	0.405	0.203	0.297	0.189

Figure 47. Static pressure loss charts.

In most small/medium shops it is only necessary to calculate the line with the longest duct length or the most fittings (operating under the assumption that if the line with the highest resistance works, the others will be fine).

To calculate the static pressure of any given line in the system, follow these steps:

1. Make a list of each size duct in the line, including the length, and multiply those numbers by the static pressure value given in the previous table.
2. List each type of elbow or branch and multiply the quantity (if more than one) by the static pressure loss given in the previous table.

3. Add the additional factors from the following table to your list.

Additional Factors	Static Pressure
Seasoned (well used) Dust Collection Filter	1"
Entry Loss at Large Machine Hood	2"

Figure 48. Additional factors affecting static pressure.

4. Total your list as shown in the example below to come up with your overall static pressure loss number for that line.

Note: Always account for a seasoned filter, so you don't end up with a system that only works right when the filter is clean.

Main Line		
6" Rigid Duct (0.037) at 20'	0.740
Branch Line		
4" Rigid Duct (0.075) at 10'	0.750
4" Flex Duct (0.28) at 5'	1.400
Elbows/Branches		
6" 45° Y-Branch	0.329
4" 45° Elbow	0.225
Additional Factors		
Seasoned Filter	<u>1.000</u>
Total Static Pressure Loss	4.444

Figure 49. Totaling static pressure numbers.

Note: When calculating static pressure loss to determine if multiple lines can be left open at the same time, only include the main line numbers once.

5. Compare the total static pressure loss for that line to the closest CFM given in **Figure 50** for your dust collector.

Example: A typical **Data Sheet Performance Curve** is illustrated in **Figure 50**. Find 4.4 on the Static Pressure axis (the amount of total static pressure loss calculated in **Figures 49-50**), then refer to the closest value on the CFM axis—approximately 1120 CFM.

The 1120 CFM for the static pressure loss of the line connected to the router is well above the 220 CFM requirement of that machine.

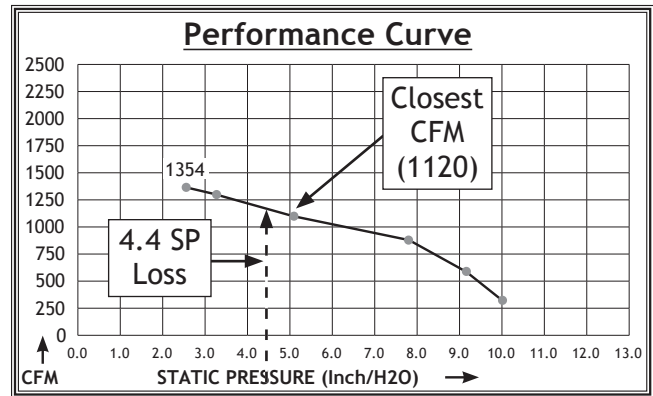

Figure 50. CFM for static pressure loss of line connected to a dust collector & router.

- If the CFM for your static pressure loss is above the requirement of the machine connected to the end of that branch line, then dust collection will most likely be successful. Congratulations! You've just designed your own dust system. Refer to the **Accessories** section on **Page 37** to start buying the components necessary to make your system a reality.
- If the CFM for your static pressure loss is below the requirement of the machine, then that line will not effectively collect the dust. You must then modify some of the factors in that line to reduce the static pressure loss. Some of the ways to do this include 1) installing larger duct, 2) reducing amount of flexible duct used, 3) increasing machine dust port size, 4) moving machine closer to dust collector to eliminate duct length, and 5) reducing 90° elbows or replacing them with 45° elbows.

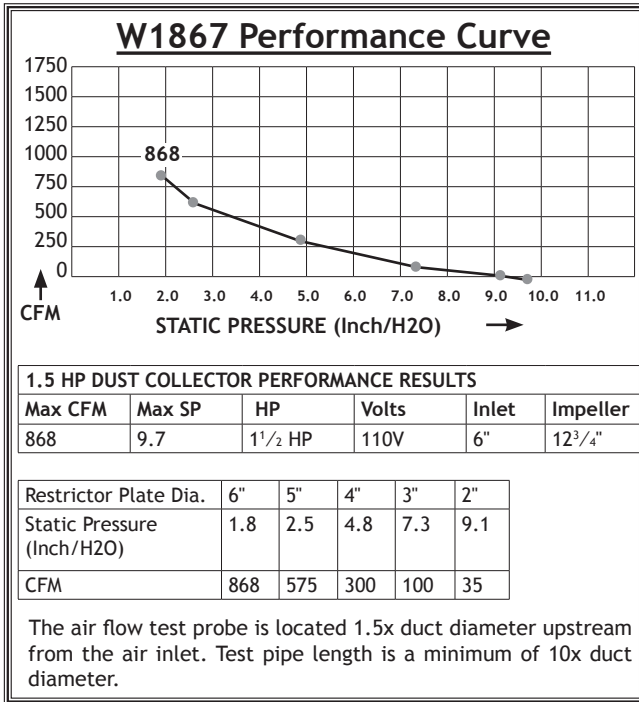

Figure 51. W1867 performance curve table and data.

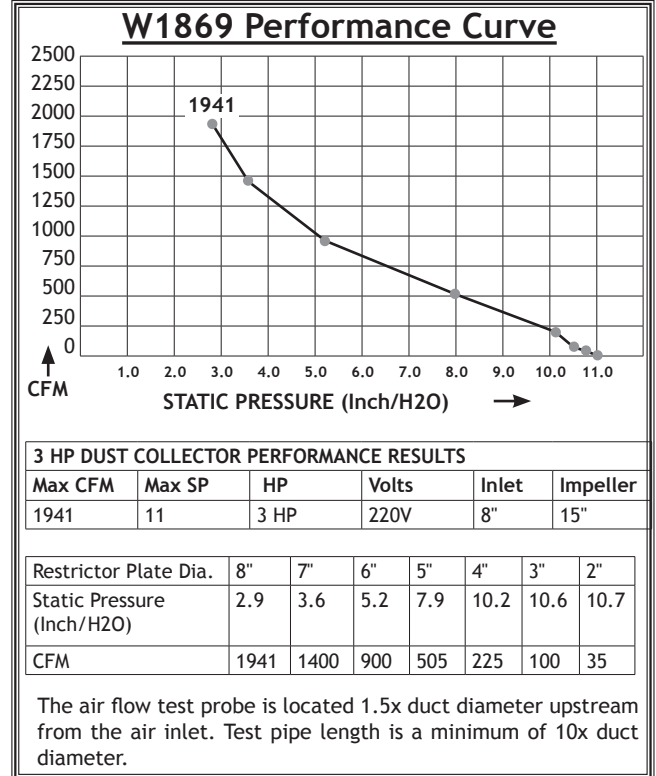

Figure 53. W1869 performance curve table and data.

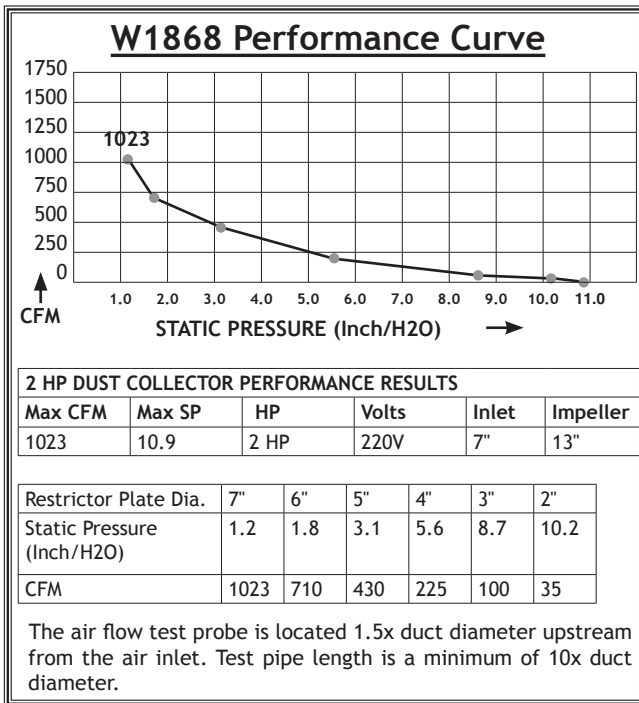

Figure 52. W1868 performance curve table and data.

System Grounding

Since plastic hose is abundant, relatively inexpensive, easily assembled and air tight, it is a very popular material for conveying dust from woodworking machines to the dust collector.

We recommend only using short lengths of flexible hose (flex-hose) to connect the woodworking machine to the dust collector. However, plastic flex-hose and plastic duct are an insulator, and dust particles moving against the walls of the plastic duct create a static electrical build up. This charge will build until it discharges to a ground.

If a grounding medium is not available to prevent static electrical build up, the electrical charge will arc to the nearest grounded source. This electrical discharge may cause an explosion and subsequent fire inside the system.

To protect against static electrical build up inside a non-conducting duct, a bare copper wire should be placed inside the duct along its length and grounded to the dust collector. You must also confirm that the dust collector is continuously grounded through the electrical circuit to the electric service panel.

If you connect the dust collector to more than one machine by way of a non-conducting branching duct system and blast gates, the system must still be grounded as mentioned above. We recommend inserting a continuous bare copper ground wire inside the entire duct system and attaching the wire to each grounded woodworking machine and dust collector.

Be sure that you extend the bare copper wire down all branches of the system. Do not forget to connect the wires to each other with wire nuts when two branches meet at a "Y" or "T" connection.

Ensure that the entire system is grounded. If using plastic blast gates to direct air flow, the grounding wire must be jumped (see the figure below) around the blast gate without interruption to the grounding system.

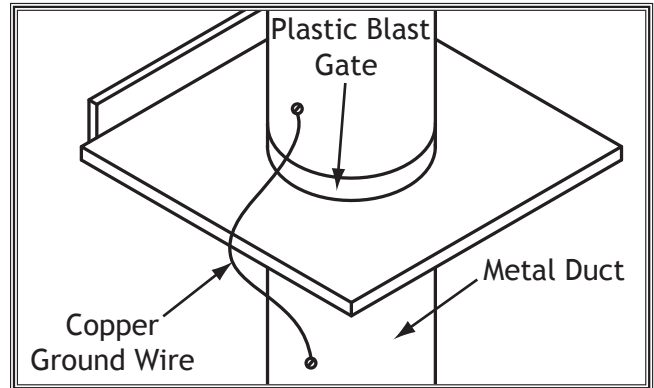

Figure 54. Ground jumper wire when using plastic blast gates and metal duct.

We also recommend wrapping the outside of all plastic ducts with bare copper wire to ground the outside of the system against static electrical build up. Wire connections at Y's and T's should be made with wire nuts.

Attach the bare ground wire to each stationary woodworking machine and attach to the dust collector frame with a ground screw as shown in the figure below. Ensure that each machine is continuously grounded to the grounding terminal in your electric service panel.

CAUTION
Always guard against static electrical build up by grounding all dust collection lines.

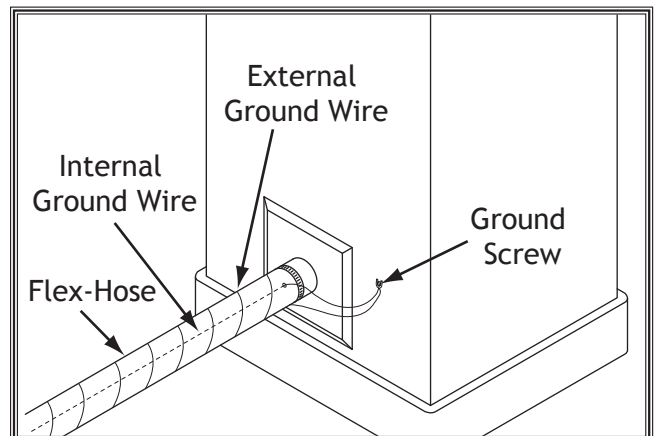

Figure 55. Flex-hose grounded to machine.

SETUP

OPERATIONS

General

The purpose of this overview is to provide the novice machine operator with a basic understanding of how the machine is used during operation, so the machine controls/components discussed later in this manual are easier to understand.

Due to the generic nature of this overview, it is not intended to be an instructional guide. To learn more about specific operations, read this entire manual, seek additional training from experienced machine operators, and do additional research outside of this manual by reading "how-to" books, trade magazines, or websites.

⚠ WARNING

To reduce your risk of serious injury or damage to the machine, read this entire manual **BEFORE** using machine.

⚠ WARNING

To reduce the risk of eye injury and long-term respiratory damage, always wear safety glasses and a respirator while operating this machine.

Operation Overview

This cyclone dust collector creates a vortex of incoming air that extracts heavy wood chips and large dust particles, and then drops them into the steel drum below, which is lined with a plastic bag.

The remaining fine dust travels past the impeller and is then caught by a canister filter and deposited in the plastic collection bag below. The spun-bond polyester filters catch 99.9 percent of particles to 1 micron in size, and are pleated to provide maximum surface area for efficient air flow.

To maintain CFM during heavy dust-collection operations, turn the filter cleaning handle back and forth to knock caked-on dust into the plastic collection bag.

Always lock all four swivel casters before operation.

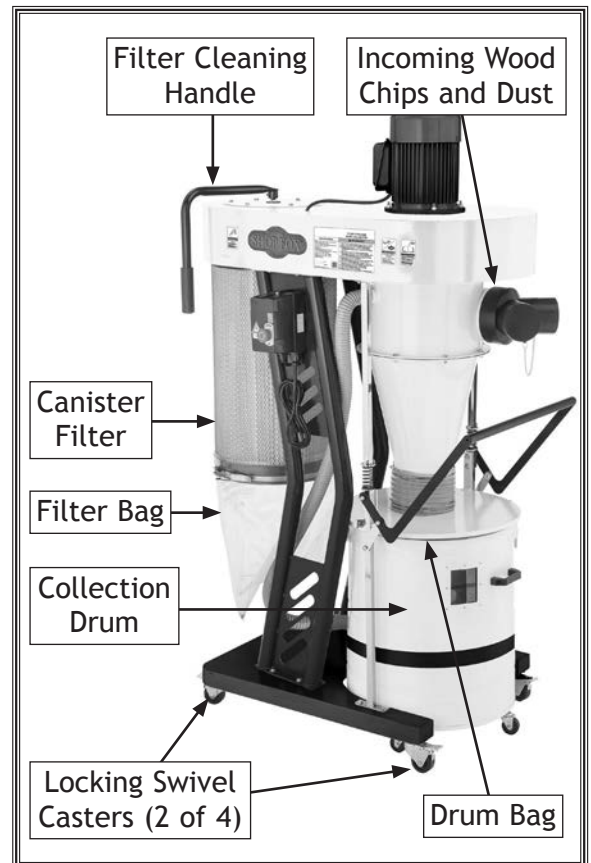

Figure 56. Dust collector operation.

ACCESSORIES

Cyclone Dust Collector Accessories

The following cyclone dust collector accessories may be available through your local Woodstock International Inc. Dealer. If you do not have a dealer in your area, these products are also available through online dealers. Please call or e-mail Woodstock International Inc. Customer Service to get a current listing of dealers at: 1-800-840-8420 or at sales@woodstockint.com.

W1050—Dust Collection Basics Book

This incisive book skillfully guides the woodworker through all the steps necessary in the design and construction of an efficient central dust-collection system and tells you what you need to know for easy installation. 64 pages.

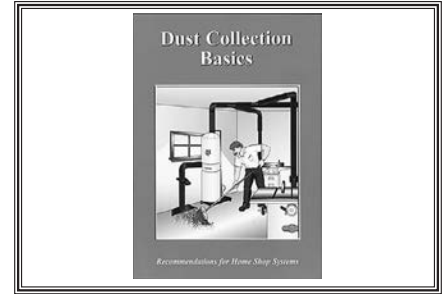

D4206—Clear Flexible Hose 4" x 10'

D4256—45° Elbow 4"

W1007—Plastic Blast Gate 4"

W1017—90° Elbow 4"

D4216—Black Flexible Hose 4" x 10'

W1053—Anti-Static Grounding Kit

W1317—Wire Hose Clamp 4"

We've handpicked a selection of commonly used dust-collection components for machines with 4" dust ports.



W1014—3" Outer Diameter Y-Fittings

W1015—4" Outer Diameter Y-Fittings

Used to attach branch lines to service more than one machine. This design provides increased lateral air flow and efficiency over other types of fittings.



OPERATIONS

W1055—Dust Collection Accessories Kit #2

Provides the necessary hoses, clamps, hoods and fittings to connect two woodworking machines to a dust collector. Air flow to each machine is controlled by a blast gate. Kit comes complete with comprehensive instructions and can be expanded even further using our other dust collection accessories (list enclosed in each box).

Kit includes:

- (2) 4" Blast gates (W1007)
- (2) 4" x 10' Hose (W1031)
- (1) Table saw dust hood (W1004)
- (1) Universal dust hood (W1010)
- (1) 4" Y-fitting (W1015)
- (10) 4" Wire hose clamps (W1317)
- Shipping weight: 15 lbs. 14 oz.
- Package size: 24" x 24" x 12"



Blast Gates

Available in both black ABS plastic and aluminum. Plastic blast gates are economically priced, have a textured surface and an easy sliding gate action. For those customers who prefer metal, our top quality aluminum blast gates feature a cast aluminum body with steel gate and locking knob. The following types and models are available:

- | | |
|--------------------------------|-------------------------|
| Black ABS plastic blast gates: | Aluminum blast gates: |
| W1006 3" Outer Diameter | W1141 3" Outer Diameter |
| W1007 4" Outer Diameter | W1142 4" Outer Diameter |
| W1008 5" Outer Diameter | |
| W1009 6" Outer Diameter | |

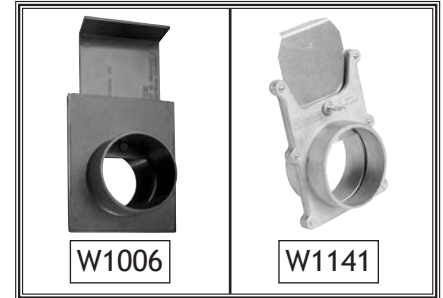

OPERATIONS

W1053—Grounding Kit

Provides everything you need to ground a dust collection system, including directions for installation. A large system may need more than one kit, so keep plenty of these on hand. This safety accessory is essential to any complete dust collection assortment.



W1039—Universal Adapter

This adapter provides a multitude of reducing options. Simply cut off unneeded steps. Outside diameter sizes include 1", 2", 2.5", 3", 4", 5", and 6". Wall thickness is 1/8".



MAINTENANCE

General

For optimum performance from this machine, this maintenance schedule must be strictly followed.

Ongoing

To maintain a low risk of injury and proper machine operation, if you ever observe any of the items below, shut down the machine immediately and fix the problem before continuing operations:

- Loose mounting bolts.
- Damaged filter canister, cleaning paddle components, or collection bags.
- Worn or damaged wires.
- Suction leaks.
- Any other unsafe condition.

Monthly Check

- Clean/vacuum dust buildup off machine body and motor.

Emptying/Replacing Collection Drum Bag



Dispose of the collection drum bag when dust fills it $\frac{3}{4}$ full. Replace the bag if it develops a leak or becomes damaged.

IMPORTANT: To contain wood dust and minimize risk of exposure, firmly tie bag closed.

If the bag gets overfilled, the dust will be sucked into the intake barrel and passed through to the canister filter and filter bag. Avoid allowing this to happen, as it may reduce filter life.

Check the drum window regularly to prevent excessive dust buildup in the collection drum.

 **CAUTION**

Dust exposure created while using machinery may cause cancer, birth defects, or long-term respiratory damage. Always wear goggles and a NIOSH-approved respirator when working with the dust collection bags or canisters.

Item(s) Needed	Qty
Drum Bag D4894 (Models W1867, W1868)	1
Drum Bag D4896 (Model W1869)	1

To remove and replace collection drum bag, do these steps:

1. DISCONNECT MACHINE FROM POWER!
2. Lift drum lock handle to lower collection drum onto casters (see **Figure 57**).
3. Release both latches on sides of drum, then roll drum clear of drum lid (see **Figure 57**).
4. Lift bag out of drum and dispose of contents.

IMPORTANT: To contain wood dust and minimize risk of exposure, tie bag closed before disposal.

5. Place new dust bag inside collection drum, and fold excess bag length over top of drum.
6. Move collection drum under lid and latch it closed.
7. Press drum lock handle down to lift collection drum off casters for operation.

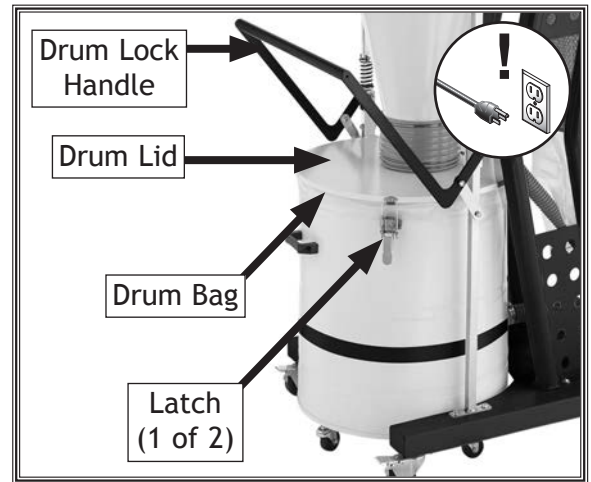

Figure 57. Collection drum bag components.

Cleaning Canister Filter

This dust collector uses a handle and internal paddles to remove excess dust and debris from the filter pleats. Move the handle back and forth through its range of motion to knock dust into the filter bag. Dispose of the bag when dust fills it about 1/2 full.

After extended use, the filter should be replaced, or thoroughly cleaned by hand.

To clean canister filter by hand, do these steps:

1. DISCONNECT MACHINE FROM POWER!
2. Remove bag clamp, filter bag, and canister filter (see **Figure 58**).
3. Rinse filter with water in an appropriate outdoor location.

IMPORTANT: DO NOT use compressed air to clean or dry the filter, as this can spread fine dust into the air and damage filter fibers.



Figure 58. Filter bag components.

4. Allow filter to air dry only. DO NOT use heat.

SERVICE

General

This section covers the most common service adjustments or procedures that may need to be made during the life of your machine.

If you require additional machine service not included in this section, please contact Woodstock International Technical Support at (360) 734-3482 or send e-mail to: techsupport@woodstockint.com.

Removing/Replacing Canister Filter & Bag

If the canister filter is clogged or dirty and cleaning it does not improve dust-collection performance, the canister filter must be replaced.

Item(s) Needed	Qty
An Assistant	1
Wrench or Socket, 12mm	1
Wrench or Socket, 10mm	1
Hex Wrench, 5mm	1
Shop Vac	1
Canister Filter D4892 (Models W1867, W1868).....	1
Canister Filter D4895 (Model W1869).....	1
Filter Bag D4893	1

To remove and replace filter bag and canister filter, do these steps:

1. DISCONNECT MACHINE FROM POWER!
2. Release bag clamp, then remove filter bag (see **Figure 59**). Tie bag closed.
3. Loosen M6-1 x 16 hex bolt on filter cleaning handle, then remove handle (see **Figure 60**).

⚠ CAUTION

Dust exposure created while using machinery may cause cancer, birth defects, or long-term respiratory damage. Always wear goggles and a NIOSH-approved respirator when working with the dust collection bags or canisters.



Figure 59. Filter bag components.

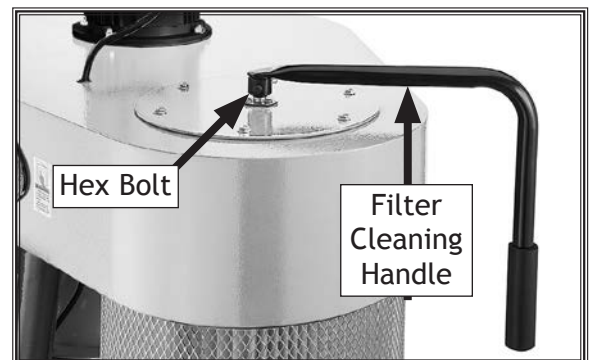

Figure 60. Filter cleaning handle hex bolt.

SERVICE

4. Remove (6) $\frac{5}{16}$ "-18 x $\frac{3}{4}$ " flange bolts securing filter paddle cover to impeller housing, then lift cover over spindle (see **Figure 61**).

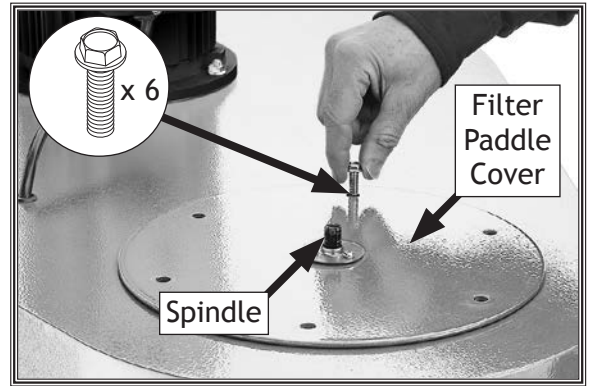

Figure 61. Removing filter paddle cover.

5. Loosen (2) M6-1 x 16 cap screws on paddle handle spindle to remove (see **Figure 62**).

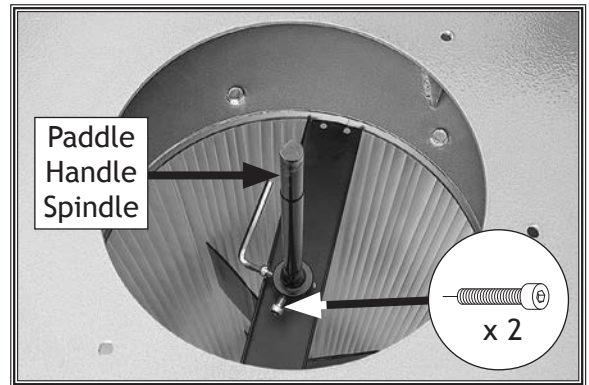

Figure 62. Separating paddle handle spindle from filter paddle spindle.

6. With assistant holding canister filter from below, loosen and remove (6) $\frac{5}{16}$ "-18 x $\frac{3}{4}$ " flange bolts securing canister filter assembly to impeller housing (see **Figure 63**).
7. Vacuum loose dust inside impeller housing and on machine.
8. Reverse **Steps 2-6** to re-assemble.

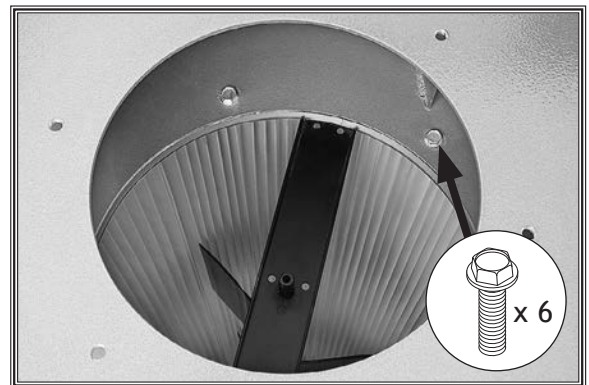

Figure 63. Remove flange bolts to remove canister filter assembly from impeller housing.

Troubleshooting

The following troubleshooting tables cover common problems that may occur with this machine. If you need replacement parts or additional troubleshooting help, contact our Technical Support.

Note: Before contacting Tech Support, find the machine serial number and manufacture date, and if available, your original purchase receipt. This information is required to properly assist you.

Motor & Electrical

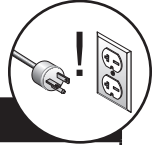

PROBLEM	POSSIBLE CAUSE	CORRECTIVE ACTION
Machine does not start or a breaker trips immediately after startup.	<ol style="list-style-type: none"> Dust collector not properly connected to ducting. E-Stop Button depressed/at fault. Incorrect power supply voltage or circuit size. Power supply circuit breaker tripped or fuse blown. Motor overheated. Machine circuit breaker has tripped. Remote control not working. Wiring open/has high resistance. Centrifugal switch/contact points at fault. Power switch/circuit breaker at fault. Start capacitor at fault. Remote receiver at fault. Motor at fault. 	<ol style="list-style-type: none"> Connect dust collector properly (Page 27). Rotate E-Stop Button to reset. Replace if at fault. Ensure correct power supply voltage and circuit size. Ensure circuit is sized correctly and free of shorts. Reset circuit breaker or replace fuse. Allow motor to cool, reset overload if necessary. Reset circuit breaker on switch. Replace battery; stay in signal range (Page 6). Check/fix broken, disconnected, or corroded wires. Adjust/replace centrifugal switch/contact points. Test/replace. Test/replace. Replace. Test/repair/replace.
Machine seems underpowered.	<ol style="list-style-type: none"> Motor overheated. Dust-collection ducting problem. Canister filter clogged/at fault. Dust collector too far from machine or undersized for dust-collection system. Run capacitor at fault. Centrifugal switch/contact points at fault. Motor bearings at fault. 	<ol style="list-style-type: none"> Allow motor to cool, reset overload if necessary. Clear blockages, seal leaks, use smooth-wall duct, eliminate bends, close other branches (Page 27). Clean canister filter (Page 40); replace canister filter (Page 41). Move closer to machine/redesign ducting layout/upgrade dust collector. Test/repair/replace. Adjust/replace centrifugal switch/contact points if available. Test by rotating shaft; rotational grinding/loose shaft requires bearing replacement.
Machine has vibration or noisy operation.	<ol style="list-style-type: none"> Motor or component loose. Motor fan rubbing on fan cover. Motor mount loose/broken. Centrifugal switch is at fault. Impeller damaged or unbalanced. Motor bearings at fault. Motor shaft bent. 	<ol style="list-style-type: none"> Inspect/replace damaged bolts/nuts, and retighten with thread-locking fluid. Fix/replace fan cover; replace loose/damaged fan. Tighten/replace. Adjust/replace centrifugal switch if available. Replace. Test by rotating shaft; rotational grinding/loose shaft requires bearing replacement. Test with dial indicator. Replace motor if damaged.
Loud, repetitious noise, or excessive vibration coming from dust collector (non-motor related).	<ol style="list-style-type: none"> Dust collector not on a flat surface and wobbles. Impeller damaged, unbalanced, or loose. Impeller loose on the motor shaft. 	<ol style="list-style-type: none"> Stabilize dust collector; lock casters. Disconnect dust collector from power. Inspect impeller for dents, bends, or loose fins. Replace impeller if damaged. Secure impeller; replace motor and impeller as a set if motor shaft and impeller hub are damaged.

Machine Operation

PROBLEM	POSSIBLE CAUSE	CORRECTIVE ACTION
Dust collector does not adequately collect dust or chips; poor performance.	<ol style="list-style-type: none"> 1. Collection bag full. 2. Canister filter clogged/at fault. 3. Ducting blocked/restricted. 4. Dust collector too far away from point of suction; duct clamps not properly secured; too many sharp bends in ducting. 5. Lumber is wet and dust is not flowing smoothly through ducting. 6. Ducting has one or more leaks, or too many open ports. 7. Not enough open branch lines at one time, causing velocity drop in main line. 8. Ducting and ports are incorrectly sized. 9. The machine dust-collection design inadequate. 10. Dust collector undersized. 	<ol style="list-style-type: none"> 1. Empty collection bag. 2. Clean canister filter (Page 40); replace canister filter (Page 41). 3. Remove ducting from dust collector inlet and unblock restriction. A plumbing snake may be necessary. 4. Relocate dust collector closer to point of suction; re-secure ducts; remove sharp bends. Refer to Designing the System in manual. 5. Only process lumber with less than 20% moisture content. 6. Seal/eliminate all ducting leaks; close dust ports for lines not being used. Refer to Designing the System in manual. 7. Open 1 or 2 more blast gates to different branch lines to increase main line velocity. 8. Install correctly sized ducts and fittings (Page 27) Refer to Designing the System in manual. 9. Use dust-collection hood on stand. 10. Install larger dust collector.
Dust collector blows sawdust into the air.	<ol style="list-style-type: none"> 1. Duct clamps or filter bag(s) are not properly clamped and secured; ducting loose/damaged. 2. Cylinder or funnel seals are loose or damaged. 	<ol style="list-style-type: none"> 1. Re-secure ducts and filter bag, making sure duct and bag clamp are tight; tighten/replace ducting. 2. Retighten all mounting and sealing points; replace damaged seals/gaskets.
Remote control does not operate dust collector.	<ol style="list-style-type: none"> 1. Emergency Stop button is pressed in. 2. Machine is disconnected from power. 3. Remote control battery is weak or dead. 4. A wall or barrier disrupts the radio frequency, or controller is too far away. 	<ol style="list-style-type: none"> 1. Rotate E-Stop button to reset. 2. Verify machine is connected to power source. 3. Replace battery. 4. Move machine away from barrier; use remote within 75' of machine.

Electrical Safety Instructions

These pages are current at the time of printing. However, in the spirit of improvement, we may make changes to the electrical systems of future machines. Compare the manufacture date of your machine to the one stated in this manual, and study this section carefully.

If there are differences between your machine and what is shown in this section, call Technical Support at (360) 734-3482 for assistance BEFORE making any changes to the wiring on your machine. An updated wiring diagram may be available. **Note:** Please gather the serial number and manufacture date of your machine before calling. This information can be found on the main machine label.

WARNING

SHOCK HAZARD. Working on wiring that is connected to a power source is extremely dangerous. Touching electrified parts will result in personal injury including but not limited to severe burns, electrocution, or death. Disconnect the power from the machine before servicing electrical components!

QUALIFIED ELECTRICIAN. Due to the inherent hazards of electricity, only a qualified electrician should perform wiring tasks on this machine. If you are not a qualified electrician, get help from one before attempting any kind of wiring job.

WIRE CONNECTIONS. All connections must be tight to prevent wires from loosening during machine operation. Double-check all wires disconnected or connected during any wiring task to ensure tight connections.

WIRE/COMPONENT DAMAGE. Damaged wires or components increase the risk of serious personal injury, fire, or machine damage. If you notice that any wires or components are damaged while performing a wiring task, replace those wires or components before completing the task.

MODIFICATIONS. Using aftermarket parts or modifying the wiring beyond what is shown in the diagram may lead to unpredictable results, including serious injury or fire.

MOTOR WIRING. The motor wiring shown in these diagrams is current at the time of printing, but it may not match your machine. Always use the wiring diagram inside the motor junction box.

CAPACITORS/INVERTERS. Some capacitors and power inverters store an electrical charge for up to 10 minutes after being disconnected from the power source. To reduce the risk of being shocked, wait at least this long before working on capacitors.

CIRCUIT REQUIREMENTS. You MUST follow the requirements at the beginning of this manual when connecting your machine to a power source.

EXPERIENCING DIFFICULTIES. If you are experiencing difficulties understanding the information included in this section, contact our Technical Support at (360) 734-3482.

NOTICE

The photos and diagrams included in this section are best viewed in color. You can view these pages in color at www.shopfox.biz.

WIRING DIAGRAM COLOR KEY

BLACK	BLUE	YELLOW	LIGHT BLUE
WHITE	BROWN	YELLOW GREEN	BLUE WHITE
GREEN	GRAY	PURPLE	TURQUOISE
RED	ORANGE	PINK	

Electrical Components

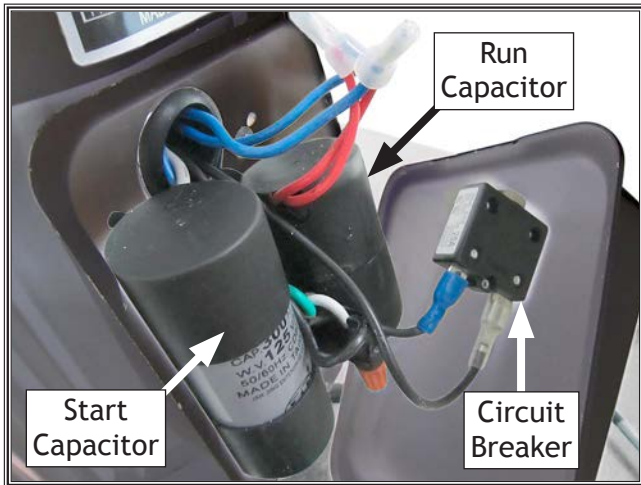

Figure 64. Junction box components (W1867 shown).

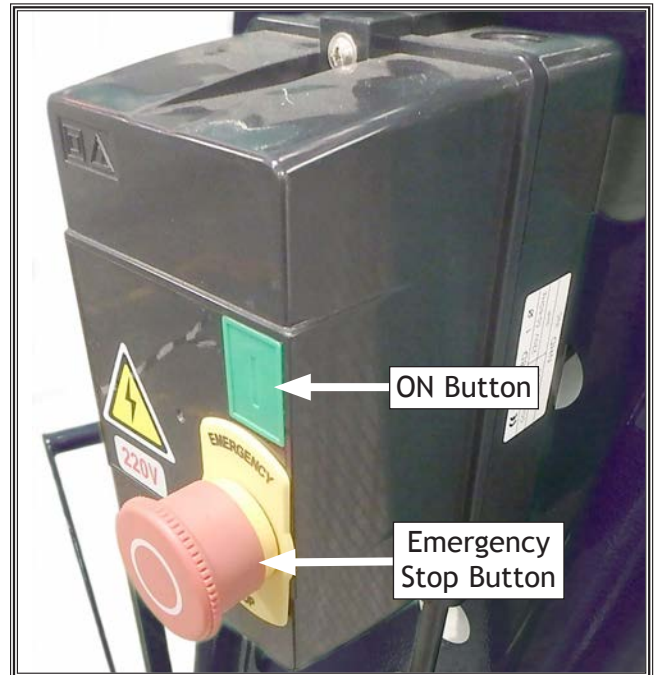

Figure 67. Magnetic switch.

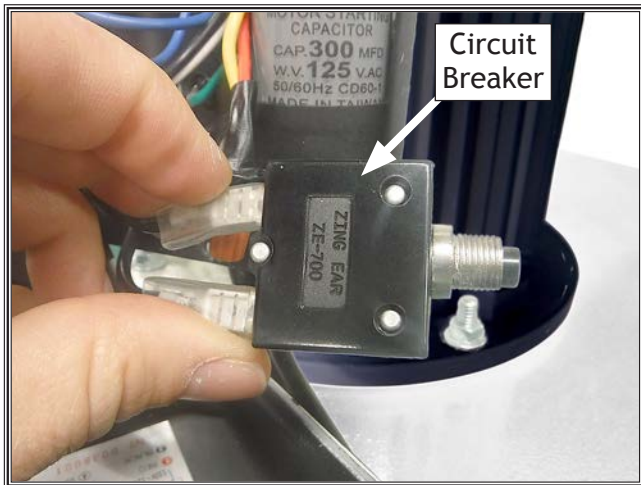

Figure 65. Circuit breaker.

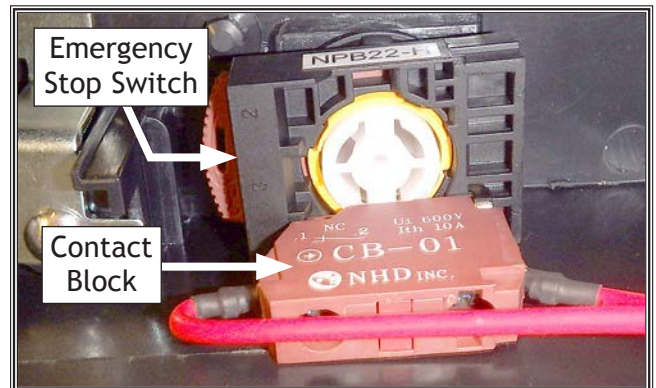

Figure 68. Emergency-stop switch and contact block.

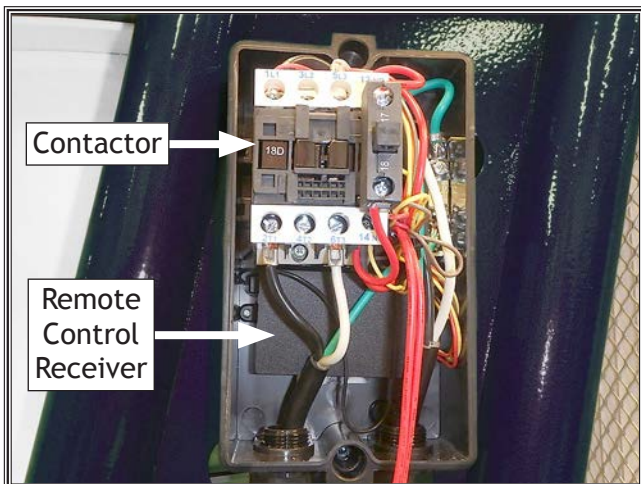

Figure 66. Contactor and remote control receiver location (W1869 shown).

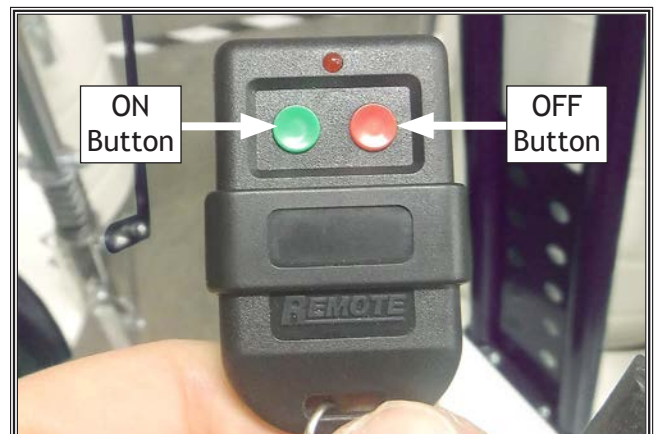
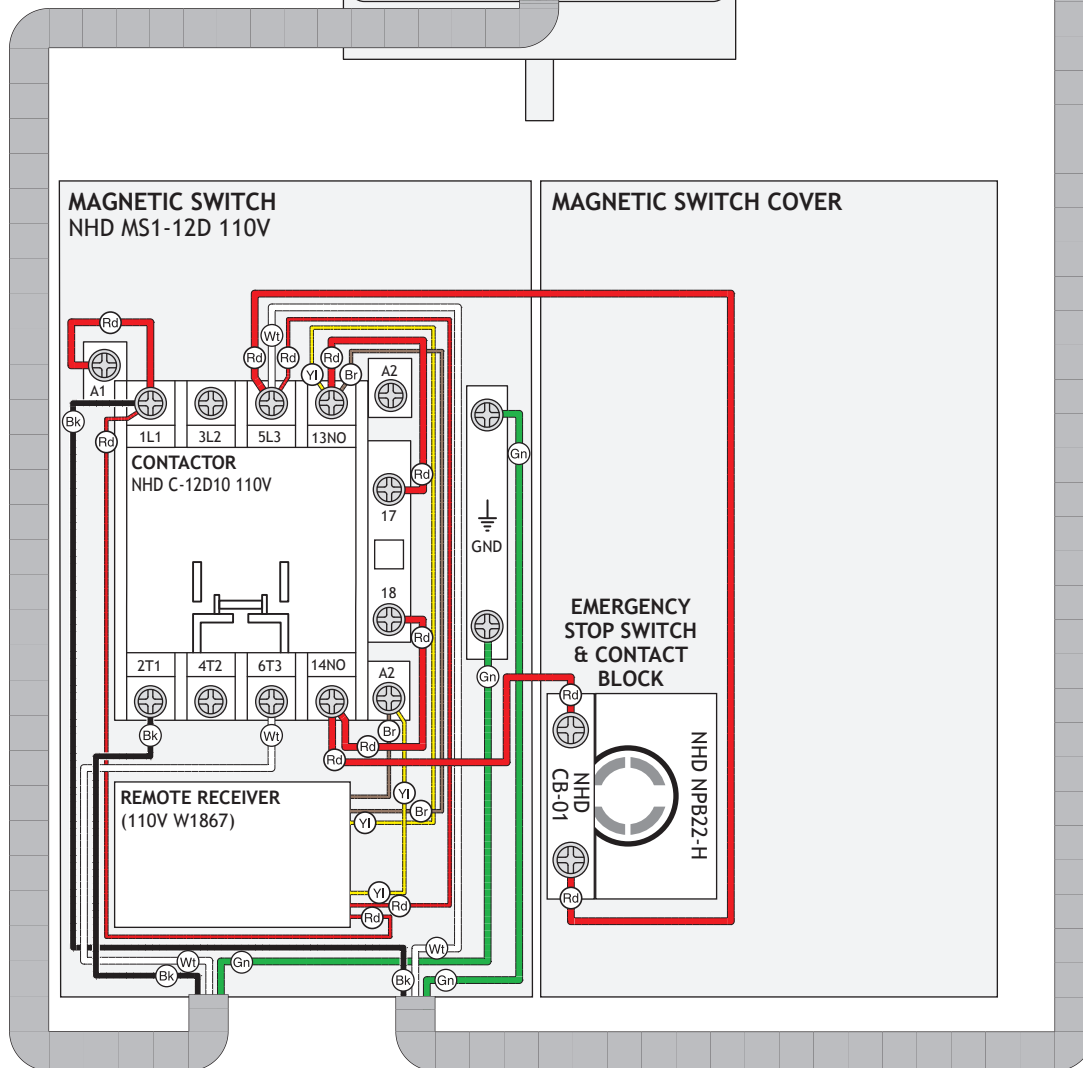
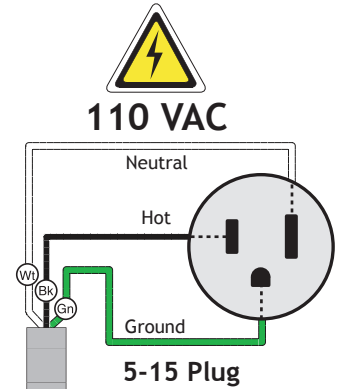
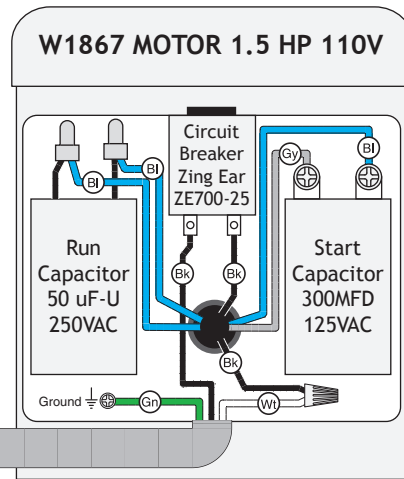

Figure 69. Remote control unit.

W1867 Wiring Diagram



NOTICE

The motor wiring shown here is current at the time of printing, but it may not match your machine. Always use the wiring diagram inside the motor junction box.



SERVICE

W1868/W1869 Wiring Diagram

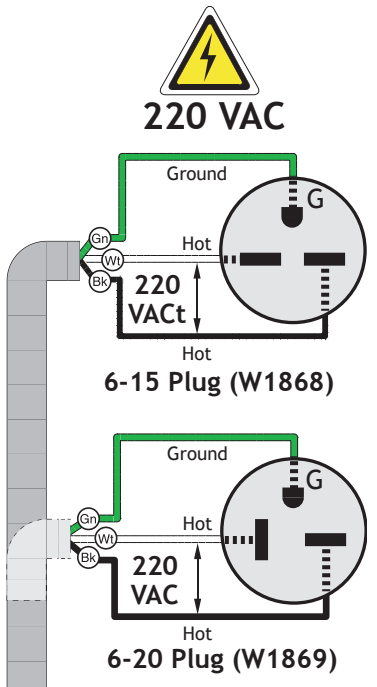
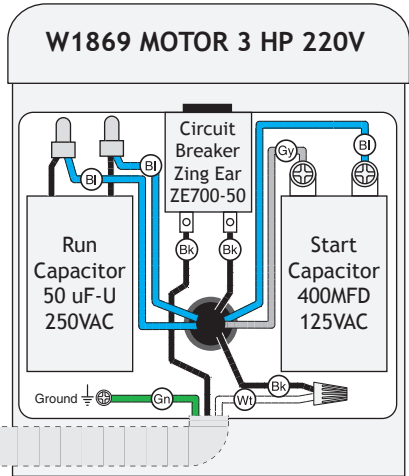
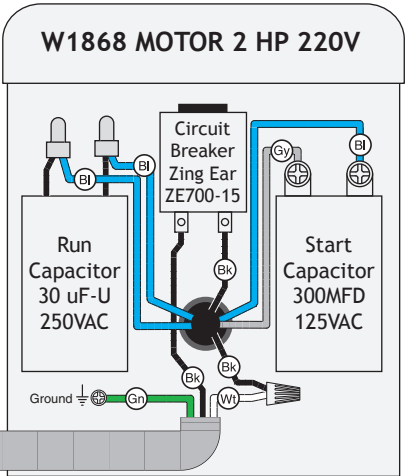

Read Page 45
STOP
Before Wiring

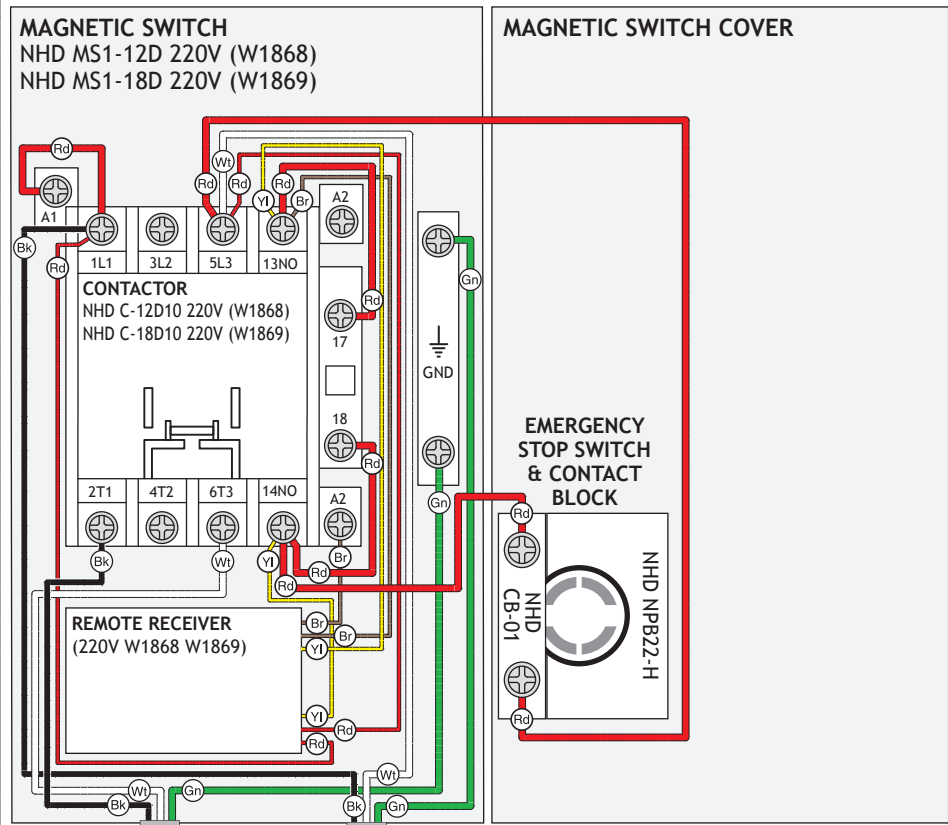

SERVICE

NOTICE

The motor wiring shown here is current at the time of printing, but it may not match your machine. Always use the wiring diagram inside the motor junction box.

WARNING!

SHOCK HAZARD!
Disconnect power before working on wiring.

W1867 Parts List

REF	PART #	DESCRIPTION
1	X1867001	BASE
2	X1867002	SUPPORT LEG
3	X1867003	IMPELLER HOUSING
4	X1867004	COLLECTION DRUM, 20 GALLON
5	X1867005	INTAKE BARREL
6	X1867006	CYCLONE FUNNEL
7	X1867007	FILTER COVER PLATE
8	X1867008	CANISTER FILTER ASSY 14-1/2" X 24"
9	X1867009	COLLECTION DRUM LID
10	X1867010	CASTER 2", SWIVEL
11	X1867011	HEX NUT 5/16-18
12	X1867012	CASTER 2-1/2", LOCKING SWIVEL
13	X1867013	INLET ADAPTER 6" X 4" X 2
14	X1867014	LOCK HANDLE GUIDE
15	X1867015	MOUNTING PLATE
16	X1867016	SPRING BRACKET
17	X1867017	COPPER PLATE
19	X1867019	HEX BOLT 5/16-18 X 1
20	X1867020	LOCK NUT 5/16-18
21	X1867021	COMPRESSION SPRING 3 X 33 X 70
22	X1867022	SPRING RETAINER
23	X1867023	DRUM LOCK HANDLE
24	X1867024	LOCK HANDLE LINK
25	X1867025	FLAT WASHER 3/8 PLASTIC
26	X1867026	BUTTON HD CAP SCR 5/16-18 X 3/4
27	X1867027	FLAT WASHER 5/16
28	X1867028	HEX BOLT 5/16-18 X 1-3/4
29	X1867029	MOTOR 1.5HP 110V 1-PH
29-1	X1867029-1	MOTOR FAN COVER
29-2	X1867029-2	MOTOR FAN
29-3	X1867029-3	MOTOR JUNCTION BOX
29-4	X1867029-4	R CAPACITOR 50M 250V 1-1/2 X 2-3/8
29-5	X1867029-5	S CAPACITOR 300M 125V 1-3/8 X 2-5/8
29-6	X1867029-6	CIRCUIT BREAKER ZING EAR ZE-700 25A
29-7	X1867029-7	STRAIN RELIEF TYPE-2 15MM
29-8	X1867029-8	CENTRIFUGAL SWITCH
29-9	X1867029-9	CONTACT PLATE
29-10	X1867029-10	MOTOR CORD W/PLUG 14G 3W 30"
29-11	X1867029-11	BALL BEARING 6203-2RS
29-12	X1867029-12	BALL BEARING 6205-2RS
31	X1867031	FENDER WASHER 5/16
32	X1867032	RUBBER GASKET 43MM
33	X1867033	BEARING RETAINER, UPPER
34	X1867034	PHLP HD SCR M5-.8 X 8
35	X1867035	SLEEVE BEARING 12 X 14 X 6MM
36	X1867036	FILTER PADDLE HANDLE
37	X1867037	FLANGE BOLT 5/16-18 X 1/2
38	X1867038	BEARING RETAINER, LOWER
39	X1867039	PADDLE HANDLE SPINDLE
40	X1867040	HEX BOLT M6-1 X 16
41	X1867041	FILTER PADDLE SPINDLE
42	X1867042	PADDLE SPINDLE BRACKET
43	X1867043	FLAT WASHER 1/4

REF	PART #	DESCRIPTION
44	X1867044	PHLP HD SCR M6-1 X 10
45	X1867045	PHLP HD SCR M5-.8 X 8
46	X1867046	PADDLE SPINDLE BRACKET RETAINER
47	X1867047	PHLP HD SCR M5-.8 X 15
49	X1867049	MAG SWITCH NHD MS1-12D 110V
49-1	X1867049-1	CONTACTOR NHD C-12D10 110V
49-2	X1867049-2	E-STOP SWITCH NHD NPB22-H
49-3	X1867049-3	CONTACT BLOCK NHD CB-01
49-4	X1867049-4	REMOTE CONTROL RECEIVER
49-5	X1867049-5	STRAIN RELIEF TYPE-3 M20-1.5
49-6	X1867049-6	MAG SWITCH BASE
49-7	X1867049-7	MAG SWITCH COVER
49-8	X1867049-8	PHLP HD SCR 10-24 X 3/4
49-9	X1867049-9	HEX NUT 10-24
50	X1867050	FILTER BAG 20" X 23"
51	X1867051	BAG CLAMP 15"
52	X1867052	INLET ADAPTER CAP 4"
53	X1867053	PHLP HD SCR 10-24 X 3/8
54	X1867054	FLANGE BOLT 5/16-18 X 3/4
55	X1867055	FLAT HD SCR 5/16-18 X 1-1/4
56	X1867056	BUTTON HD CAP SCR 5/16-18 X 1/2
57	X1867057	COLLECTION DRUM LID LATCH
58	X1867058	FLEX HOSE 7" X 5"
59	X1867059	FILTER PADDLE
60	X1867060	HEX BOLT M6-1 X 12
61	X1867061	FOAM GASKET, 120 X 140MM
62	X1867062	DRUM WINDOW, 120 X 140MM ACRYLIC
63	X1867063	RIVET 2 X 4MM
64	X1867064	COLLECTION DRUM HANDLE
65	X1867065	PHLP HD SCR 1/4-20 X 5/8
66	X1867066	ACORN NUT 1/4-20
67	X1867067	REMOTE CONTROL
67-1	X1867067-1	REMOTE BATTERY TYPE A27 12V
68	X1867068	PHLP HD SCR M4-.7 X 8
69	X1867069	LOCK NUT M4-.7
70	X1867070	IMPELLER 12-3/4"
71	X1867071	IMPELLER WASHER 6 X 38 X 4MM
72	X1867072	CAP SCREW M6-1 X 30
73	X1867073	COLLECTION DRUM GASKET
74	X1867074	HOSE CLAMP 1-3/4"
75	X1867075	VACUUM HOSE 1-1/2" X 60"
76	X1867076	HOSE CLAMP 8-1/2"
77	X1867077	POWER CORD 14G 3W 72" 5-15P
78	X1867078	VACUUM RING
79	X1867079	COLLECTION DRUM BAG 30" X 41"
80	X1867080	GROUND WIRE 18G 17-1/2"
81	X1867081	PHLP HD SCR 10-24 X 3/8
82	X1867082	HEX NUT 10-24
83	X1867083	FLANGE NUT 5/16-18
84	X1867084	LOCK HANDLE STOP
85	X1867085	KEY 7 X 7 X 29
86	X1867086	CAP SCREW M6-1 X 16
87	X1867087	EXT TOOTH WASHER #10



W1868 Parts List

REF	PART #	DESCRIPTION	REF	PART #	DESCRIPTION
1	X1868001	BASE	44	X1868044	PHLP HD SCR M6-1 X 10
2	X1868002	SUPPORT LEG	45	X1868045	PHLP HD SCR M5-.8 X 8
3	X1868003	IMPELLER HOUSING	46	X1868046	PADDLE SPINDLE BRACKET RETAINER
4	X1868004	COLLECTION DRUM, 20 GALLON	47	X1868047	PHLP HD SCR M5-.8 X 15
5	X1868005	INTAKE BARREL	49	X1868049	MAG SWITCH NHD MS1-12D 220V
6	X1868006	CYCLONE FUNNEL	49-1	X1868049-1	CONTACTOR NHD C-12D10 220V
7	X1868007	FILTER COVER PLATE	49-2	X1868049-2	E-STOP SWITCH NHD NPB22-H
8	X1868008	CANISTER FILTER ASSY 14-1/2" X 24"	49-3	X1868049-3	CONTACT BLOCK NHD CB-01
9	X1868009	COLLECTION DRUM LID	49-4	X1868049-4	REMOTE CONTROL RECEIVER
10	X1868010	CASTER 2", SWIVEL	49-5	X1868049-5	STRAIN RELIEF TYPE-3 M20-1.5
11	X1868011	HEX NUT 5/16-18	49-6	X1868049-6	MAG SWITCH BASE
12	X1868012	CASTER 2-1/2", LOCKING SWIVEL	49-7	X1868049-7	MAG SWITCH COVER
13	X1868013	INLET ADAPTER 7" X 4" X 3	49-8	X1868049-8	PHLP HD SCR 10-24 X 3/4
14	X1868014	LOCK HANDLE GUIDE	49-9	X1868049-9	HEX NUT 10-24
15	X1868015	MOUNTING PLATE	50	X1868050	FILTER BAG 20" X 23"
16	X1868016	SPRING BRACKET	51	X1868051	BAG CLAMP 15"
17	X1868017	COPPER PLATE	52	X1868052	INLET ADAPTER CAP 4"
19	X1868019	HEX BOLT 5/16-18 X 1	53	X1868053	PHLP HD SCR 10-24 X 3/8
20	X1868020	LOCK NUT 5/16-18	54	X1868054	FLANGE BOLT 5/16-18 X 3/4
21	X1868021	COMPRESSION SPRING 3 X 33 X 70	55	X1868055	FLAT HD SCR 5/16-18 X 1-1/4
22	X1868022	SPRING RETAINER	56	X1868056	BUTTON HD CAP SCR 5/16-18 X 1/2
23	X1868023	DRUM LOCK HANDLE	57	X1868057	COLLECTION DRUM LID LATCH
24	X1868024	LOCK HANDLE LINK	58	X1868058	FLEX HOSE 8" X 7"
25	X1868025	FLAT WASHER 3/8 PLASTIC	59	X1868059	FILTER PADDLE
26	X1868026	BUTTON HD CAP SCR 5/16-18 X 3/4	60	X1868060	HEX BOLT M6-1 X 12
27	X1868027	FLAT WASHER 5/16	61	X1868061	FOAM GASKET 120 X 140MM
28	X1868028	HEX BOLT 5/16-18 X 1-3/4	62	X1868062	DRUM WINDOW, 120 X 140MM ACRYLIC
29	X1868029	MOTOR 2HP 220V 1-PH	63	X1868063	RIVET 2 X 4MM
29-1	X1868029-1	MOTOR FAN COVER	64	X1868064	COLLECTION DRUM HANDLE
29-2	X1868029-2	MOTOR FAN	65	X1868065	PHLP HD SCR 1/4-20 X 5/8
29-3	X1868029-3	MOTOR JUNCTION BOX	66	X1868066	ACORN NUT 1/4-20
29-4	X1868029-4	R CAPACITOR 30M 250V 1-1/2 X 2-3/8	67	X1868067	REMOTE CONTROL
29-5	X1868029-5	S CAPACITOR 300M 125V 1-3/8 X 2-5/8	67-1	X1868067-1	REMOTE BATTERY TYPE A27 12V
29-6	X1868029-6	CIRCUIT BREAKER ZING EAR ZE-700 15A	68	X1868068	PHLP HD SCR M4-.7 X 8
29-7	X1868029-7	STRAIN RELIEF TYPE-2 15MM	69	X1868069	LOCK NUT M4-.7
29-8	X1868029-8	CENTRIFUGAL SWITCH	70	X1868070	IMPELLER 13"
29-9	X1868029-9	CONTACT PLATE	71	X1868071	IMPELLER WASHER 6 X 38 X 4MM
29-10	X1868029-10	MOTOR CORD W/PLUG 14G 3W 30"	72	X1868072	CAP SCREW M6-1 X 30
29-11	X1868029-11	BALL BEARING 6203-2RS	73	X1868073	COLLECTION DRUM GASKET
29-12	X1868029-12	BALL BEARING 6205-2RS	74	X1868074	HOSE CLAMP 1-3/4"
31	X1868031	FENDER WASHER 5/16	75	X1868075	VACUUM HOSE 1-1/2" X 60"
32	X1868032	RUBBER GASKET 43MM	76	X1868076	HOSE CLAMP 8-1/2"
33	X1868033	BEARING RETAINER, UPPER	77	X1868077	POWER CORD 14G 3W 72" 6-15P
34	X1868034	PHLP HD SCR M5-.8 X 8	78	X1868078	VACUUM RING
35	X1868035	SLEEVE BEARING 12 X 14 X 6MM	79	X1868079	COLLECTION DRUM BAG 30" X 41"
36	X1868036	FILTER PADDLE HANDLE	80	X1868080	GROUND WIRE 18G 17-1/2"
37	X1868037	FLANGE BOLT 5/16-18 X 1/2	81	X1868081	PHLP HD SCR 10-24 X 3/8
38	X1868038	BEARING RETAINER, LOWER	82	X1868082	HEX NUT 10-24
39	X1868039	PADDLE HANDLE SPINDLE	83	X1868083	FLANGE NUT 5/16-18
40	X1868040	HEX BOLT M6-1 X 16	84	X1868084	LOCK HANDLE STOP
41	X1868041	FILTER PADDLE SPINDLE	85	X1868085	KEY 7 X 7 X 29
42	X1868042	PADDLE SPINDLE BRACKET	86	X1868086	CAP SCREW M6-1 X 16
43	X1868043	FLAT WASHER 1/4	87	X1868087	EXT TOOTH WASHER #10

W1869 Parts List

REF	PART #	DESCRIPTION
1	X1869001	BASE
2	X1869002	SUPPORT LEG
3	X1869003	IMPELLER HOUSING
4	X1869004	COLLECTION DRUM, 38 GALLON
5	X1869005	INTAKE BARREL
6	X1869006	CYCLONE FUNNEL
7	X1869007	FILTER COVER PLATE
8	X1869008	CANISTER FILTER ASSY 14-1/2" X 39-3/8"
9	X1869009	COLLECTION DRUM LID
10	X1869010	CASTER 2", SWIVEL
11	X1869011	HEX NUT 5/16-18
12	X1869012	CASTER 2-1/2", LOCKING SWIVEL
13	X1869013	INLET ADAPTER 8" X 4" X 3
14	X1869014	LOCK HANDLE GUIDE
15	X1869015	MOUNTING PLATE
16	X1869016	SPRING BRACKET
17	X1869017	COPPER PLATE
19	X1869019	HEX BOLT 5/16-18 X 1
20	X1869020	LOCK NUT 5/16-18
21	X1869021	COMPRESSION SPRING 3 X 33 X 70
22	X1869022	SPRING RETAINER
23	X1869023	DRUM LOCK HANDLE
24	X1869024	LOCK HANDLE LINK
25	X1869025	FLAT WASHER 3/8 PLASTIC
26	X1869026	BUTTON HD CAP SCR 5/16-18 X 3/4
27	X1869027	FLAT WASHER 5/16
28	X1869028	HEX BOLT 5/16-18 X 1-3/4
29	X1869029	MOTOR 3HP 220V 1-PH
29-1	X1869029-1	MOTOR FAN COVER
29-2	X1869029-2	MOTOR FAN
29-3	X1869029-3	MOTOR JUNCTION BOX
29-4	X1869029-4	R CAPACITOR 50M 250V 1-1/2 X 2-3/8
29-5	X1869029-5	S CAPACITOR 400M 125V 1-3/8 X 2-3/4
29-6	X1869029-6	CIRCUIT BREAKER ZING EAR ZE-700 50A
29-7	X1869029-7	STRAIN RELIEF TYPE-2 15MM
29-8	X1869029-8	CENTRIFUGAL SWITCH
29-9	X1869029-9	CONTACT PLATE
29-10	X1869029-10	MOTOR CORD W/PLUG 12G 3W 30"
29-11	X1869029-11	BALL BEARING 6205-2RS
29-12	X1869029-12	BALL BEARING 6206-2RS
31	X1869031	FENDER WASHER 5/16
32	X1869032	RUBBER GASKET 43MM
33	X1869033	BEARING RETAINER, UPPER
34	X1869034	PHLP HD SCR M5-.8 X 8
35	X1869035	SLEEVE BEARING 12 X 14 X 6MM
36	X1869036	FILTER PADDLE HANDLE
37	X1869037	FLANGE BOLT 5/16-18 X 1/2
38	X1869038	BEARING RETAINER, LOWER
39	X1869039	PADDLE HANDLE SPINDLE
40	X1869040	HEX BOLT M6-1 X 16
41	X1869041	FILTER PADDLE SPINDLE
42	X1869042	PADDLE SPINDLE BRACKET
43	X1869043	FLAT WASHER 1/4
44	X1869044	PHLP HD SCR M6-1 X 10

REF	PART #	DESCRIPTION
45	X1869045	PHLP HD SCR M5-.8 X 8
46	X1869046	PADDLE SPINDLE BRACKET RETAINER
47	X1869047	PHLP HD SCR M5-.8 X 15
49	X1869049	MAG SWITCH NHD MS1-18D 220V
49-1	X1869049-1	CONTACTOR NHD C-18D10 220V
49-2	X1869049-2	E-STOP SWITCH NHD NPB22-H
49-3	X1869049-3	CONTACT BLOCK NHD CB-01
49-4	X1869049-4	REMOTE CONTROL RECEIVER
49-5	X1869049-5	STRAIN RELIEF TYPE-3 M20-1.5
49-6	X1869049-6	MAG SWITCH BASE
49-7	X1869049-7	MAG SWITCH COVER
49-8	X1869049-8	PHLP HD SCR 10-24 X 3/4
49-9	X1869049-9	HEX NUT 10-24
50	X1869050	FILTER BAG 20" X 23"
51	X1869051	BAG CLAMP 15"
52	X1869052	INLET ADAPTER CAP 4"
53	X1869053	PHLP HD SCR 10-24 X 3/8
54	X1869054	FLANGE BOLT 5/16-18 X 3/4
55	X1869055	FLAT HD SCR 5/16-18 X 1-1/4
56	X1869056	BUTTON HD CAP SCR 5/16-18 X 1/2
57	X1869057	COLLECTION DRUM LID LATCH
58	X1869058	FLEX HOSE 12" X 9-1/2"
59	X1869059	FILTER PADDLE
60	X1869060	HEX BOLT M6-1 X 16
61	X1869061	FOAM GASKET, 120 X 140MM
62	X1869062	DRUM WINDOW, 120 X 140MM ACRYLIC
63	X1869063	RIVET 2 X 4MM
64	X1869064	COLLECTION DRUM HANDLE
65	X1869065	PHLP HD SCR 1/4-20 X 5/8
66	X1869066	ACORN NUT 1/4-20
67	X1869067	REMOTE CONTROL
67-1	X1869067-1	REMOTE BATTERY TYPE A27 12V
68	X1869068	PHLP HD SCR M4-.7 X 8
69	X1869069	LOCK NUT M4-.7
70	X1869070	IMPELLER 15"
71	X1869071	IMPELLER WASHER 6 X 38 X 4MM
72	X1869072	CAP SCREW M6-1 X 30
73	X1869073	COLLECTION DRUM GASKET
74	X1869074	HOSE CLAMP 1-3/4"
75	X1869075	VACUUM HOSE 1-1/2" X 60"
76	X1869076	HOSE CLAMP 8-1/2"
77	X1869077	POWER CORD 12G 3W 72" 6-20P
78	X1869078	VACUUM RING
79	X1869079	COLLECTION DRUM BAG 39" X 56"
80	X1869080	GROUND WIRE 18G 17-1/2"
81	X1869081	PHLP HD SCR 10-24 X 3/8
82	X1869082	HEX NUT 10-24
83	X1869083	FLANGE NUT 5/16-18
84	X1869084	LOCK HANDLE STOP
85	X1869085	KEY 7 X 7 X 30
86	X1869086	CAP SCREW M6-1 X 16
87	X1869087	EXT TOOTH WASHER #10
88	X1869088	HEX BOLT 3/8-16 X 1/2

W1867/W1868 Labels & Cosmetics

W1867 W1868

**MODEL W1867
1.5 HP CYCLONE
DUST COLLECTOR**

Specifications

Motor: 1.5 HP, 110V, Single-Phase, 60 Hz
Full-Load Current Rating: 15A
Airflow Performance: 860 CFM @ 1.8" SP
Max. Static Pressure: 5.2"
Inlet Size: 6"
Collection Drum Size: 20 Gallons
Filter Rating: 99.9% at 0.2 - 1 Micron
Cartridge Filter: 14-1/2" x 24"
Replacement Filter: D4892
Replacement Drum Bag: D4894
Weight: 265 lbs.

WARNING!

To reduce the risk of serious injury when using this machine:

1. Read and understand owner's manual before operating.
2. Always wear approved eye protection and respirator.
3. Only plug power cord into a grounded outlet.
4. Only use this machine to collect wood dust/chips; never use to collect glass, metal, liquids, asbestos, silica, animal parts, biohazards, burning materials/ashes, etc.
5. Always disconnect power before servicing or cleaning.
6. Do not expose to rain or wet areas.
7. Keep hands, long hair, and loose clothing away from inlet.
8. Never leave machine unattended during operation.
9. Do not use if cord, plug, or any other electrical equipment becomes damaged—promptly repair!
10. Do not use without dust bag or filters in place.
11. Do not connect cord to power supply with wet hands.
12. Grasp and pull the plug, not the cord, when unplugging.
13. Always wear a respirator when emptying bags.
14. Do not modify machine in any way.
15. Prevent unauthorized use by children or untrained users; restrict access or disable machine when unattended.

____ Date
____ SSI

SSI, for Woodstock in Taiwan

**MODEL W1868
2 HP CYCLONE
DUST COLLECTOR**

Specifications

Motor: 2 HP, 220V, Single-Phase, 60 Hz
Full-Load Current Rating: 9A
Airflow Performance: 1020 CFM @ 1.2" SP
Max. Static Pressure: 10.2"
Inlet Size: 7"
Collection Drum Size: 20 Gallons
Filter Rating: 99.9% at 1 Micron
Cartridge Filter: 14-1/2" x 24"
Replacement Filter: D4892
Replacement Drum Bag: D4894
Weight: 295 lbs.

WARNING!

To reduce the risk of serious injury when using this machine:

1. Read and understand owner's manual before operating.
2. Always wear approved eye protection and respirator.
3. Only plug power cord into a grounded outlet.
4. Only use this machine to collect wood dust/chips; never use to collect glass, metal, liquids, asbestos, silica, animal parts, biohazards, burning materials/ashes, etc.
5. Always disconnect power before servicing or cleaning.
6. Do not expose to rain or wet areas.
7. Keep hands, long hair, and loose clothing away from inlet.
8. Never leave machine unattended during operation.
9. Do not use if cord, plug, or any other electrical equipment becomes damaged—promptly repair!
10. Do not use without dust bag or filters in place.
11. Do not connect cord to power supply with wet hands.
12. Grasp and pull the plug, not the cord, when unplugging.
13. Always wear a respirator when emptying bags.
14. Do not modify machine in any way.
15. Prevent unauthorized use by children or untrained users; restrict access or disable machine when unattended.

____ Date
____ SSI

SSI, for Woodstock in Taiwan

WARNING!
ACCIDENTAL INJURY
HAZARD!
Disconnect power
supply before
adjustments, setup
or maintenance!

WARNING!
READ and UNDERSTAND
MANUAL to avoid serious
injury! If a manual is not
available, DO NOT use
machine! Instead, go to:
www.shopfox.com
or call (360) 734-3482.

WARNING!
INJURY HAZARD!
To reduce risk of short
and long-term injury,
wear safety glasses,
hearing protection, and
a respirator when using
this machine.



REF	PART #	DESCRIPTION
101	X1867101	MACHINE ID LABEL (W1867)
101	X1868101	MACHINE ID LABEL (W1868)
102	X1867102	ELECTRICITY WARNING LABEL
103	X1867103	MODEL NO. LABEL (W1867)
103	X1868103	MODEL NO. LABEL (W1868)
104	X1867104	READ MANUAL LABEL

REF	PART #	DESCRIPTION
105	X1867105	EYE/EAR/LUNG WARNING LABEL
106	X1867106	TOUCH-UP PAINT, SHOP FOX WHITE
107	X1867107	BLACK TRIM TAPE
108	X1867108	TOUCH-UP PAINT, SHOP FOX BLACK
109	X1867109	SHOP FOX NAMEPLATE-MEDIUM
110	X1867110	DISCONNECT POWER LABEL

⚠ WARNING

Safety labels warn about machine hazards and how to prevent serious personal injury. The owner of this machine **MUST** maintain the original location and readability of all labels on this machine. If any label is removed or becomes unreadable, **REPLACE** that label before allowing machine to be operated again. Contact us at (360) 734-3482 or www.woodstockint.com to order new labels.

W1869 Labels & Cosmetics

W1869

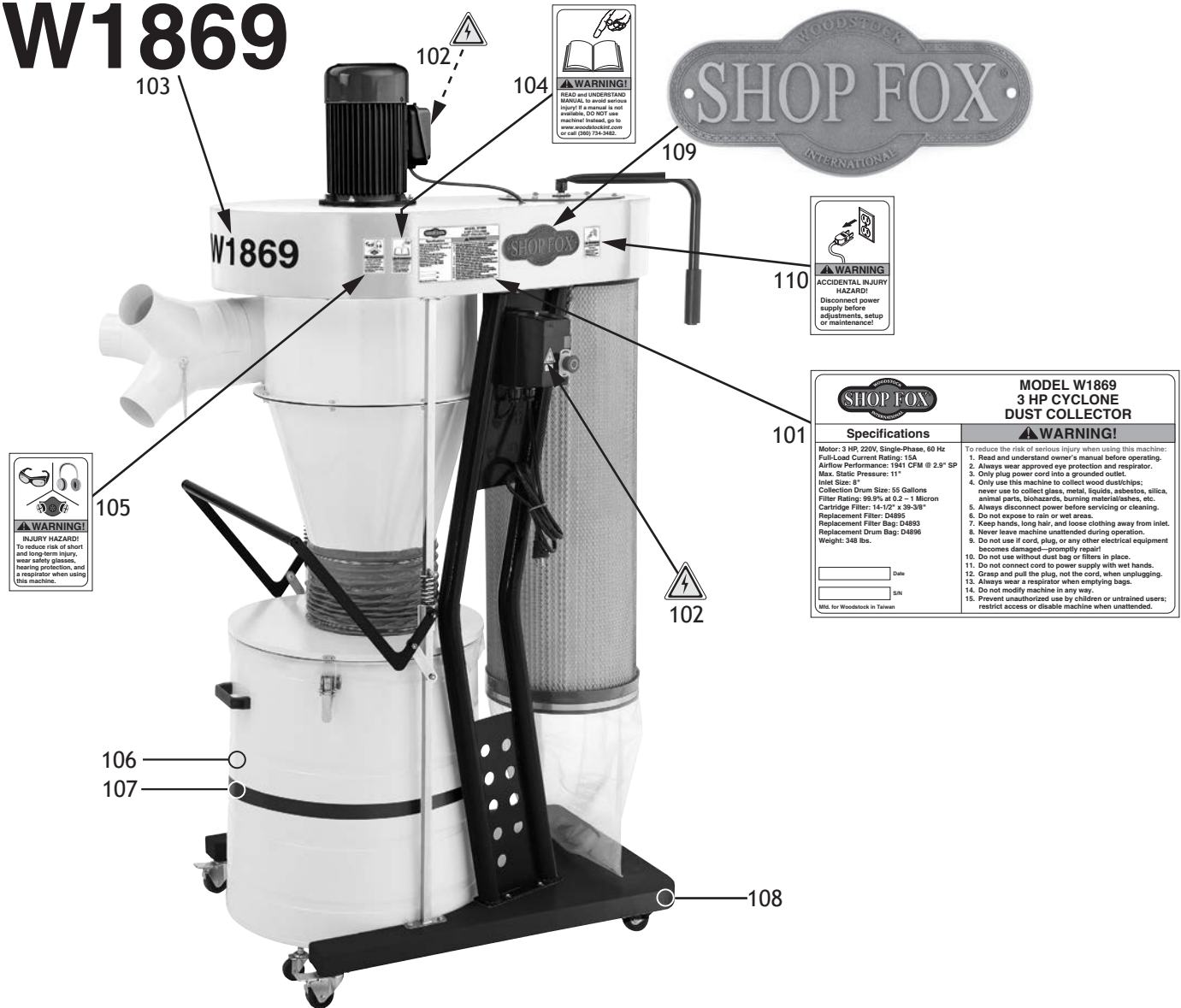

REF	PART #	DESCRIPTION
101	W1869101	MACHINE ID LABEL
102	W1869102	ELECTRICITY WARNING LABEL
103	W1869103	MODEL NO. LABEL
104	W1869104	READ MANUAL LABEL
105	W1869105	EYE/EAR/LUNG WARNING LABEL

REF	PART #	DESCRIPTION
106	W1869106	TOUCH-UP PAINT, SHOP FOX WHITE
107	W1869107	BLACK TRIM TAPE
108	W1869108	TOUCH-UP PAINT, SHOP FOX BLACK
109	W1869109	SHOP FOX NAMEPLATE-MEDIUM
110	W1869110	DISCONNECT POWER LABEL

⚠ WARNING

Safety labels warn about machine hazards and how to prevent serious personal injury. The owner of this machine **MUST** maintain the original location and readability of all labels on this machine. If any label is removed or becomes unreadable, **REPLACE** that label before allowing machine to be operated again. Contact us at (360) 734-3482 or www.woodstockint.com to order new labels.



Warranty Registration

Name _____
 Street _____
 City _____ State _____ Zip _____
 Phone # _____ Email _____ Invoice # _____
 Model # _____ Serial # _____ Dealer Name _____ Purchase Date _____

The following information is given on a voluntary basis. It will be used for marketing purposes to help us develop better products and services. Of course, all information is strictly confidential.

- How did you learn about us?
 Advertisement Friend Local Store
 Mail Order Catalog Website Other:
- How long have you been a woodworker/metalworker?
 0-2 Years 2-8 Years 8-20 Years 20+ Years
- How many of your machines or tools are Shop Fox?
 0-2 3-5 6-9 10+
- Do you think your machine represents a good value? Yes No
- Would you recommend Shop Fox products to a friend? Yes No
- What is your age group?
 20-29 30-39 40-49
 50-59 60-69 70+
- What is your annual household income?
 \$20,000-\$29,000 \$30,000-\$39,000 \$40,000-\$49,000
 \$50,000-\$59,000 \$60,000-\$69,000 \$70,000+
- Which of the following magazines do you subscribe to?

<input type="checkbox"/> Cabinet Maker	<input type="checkbox"/> Popular Mechanics	<input type="checkbox"/> Today's Homeowner
<input type="checkbox"/> Family Handyman	<input type="checkbox"/> Popular Science	<input type="checkbox"/> Wood
<input type="checkbox"/> Hand Loader	<input type="checkbox"/> Popular Woodworking	<input type="checkbox"/> Wooden Boat
<input type="checkbox"/> Handy	<input type="checkbox"/> Practical Homeowner	<input type="checkbox"/> Woodshop News
<input type="checkbox"/> Home Shop Machinist	<input type="checkbox"/> Precision Shooter	<input type="checkbox"/> Woodsmith
<input type="checkbox"/> Journal of Light Cont.	<input type="checkbox"/> Projects in Metal	<input type="checkbox"/> Woodwork
<input type="checkbox"/> Live Steam	<input type="checkbox"/> RC Modeler	<input type="checkbox"/> Woodworker West
<input type="checkbox"/> Model Airplane News	<input type="checkbox"/> Rifle	<input type="checkbox"/> Woodworker's Journal
<input type="checkbox"/> Modeltec	<input type="checkbox"/> Shop Notes	<input type="checkbox"/> Other:
<input type="checkbox"/> Old House Journal	<input type="checkbox"/> Shotgun News	

9. Comments: _____

CUT ALONG DOTTED LINE

FOLD ALONG DOTTED LINE

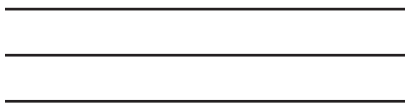

Place
Stamp
Here



WOODSTOCK INTERNATIONAL INC.
P.O. BOX 2309
BELLINGHAM, WA 98227-2309



FOLD ALONG DOTTED LINE

TAPE ALONG EDGES--PLEASE DO NOT STAPLE

WARRANTY

Woodstock International, Inc. warrants all Shop Fox machinery to be free of defects from workmanship and materials for a period of two years from the date of original purchase by the original owner. This warranty does not apply to defects due directly or indirectly to misuse, abuse, negligence or accidents, lack of maintenance, or reimbursement of third party expenses incurred.

Woodstock International, Inc. will repair, replace, or arrange for a dealer refund, at its expense and option, the Shop Fox machine or machine part proven to be defective for its designed and intended use, provided that the original owner returns the product prepaid to an authorized warranty or repair facility as designated by our Bellingham, Washington office with proof of their purchase of the product within two years, and provides Woodstock International, Inc. reasonable opportunity to verify the alleged defect through inspection. If it is determined there is no defect, or that the defect resulted from causes not within the scope of Woodstock International Inc.'s warranty, then the original owner must bear the cost of storing and returning the product.

This is Woodstock International, Inc.'s sole written warranty and any and all warranties that may be implied by law, including any merchantability or fitness, for any particular purpose, are hereby limited to the duration of this written warranty. We do not warrant that Shop Fox machinery complies with the provisions of any law, acts or electrical codes. We do not reimburse for third party repairs. In no event shall Woodstock International, Inc.'s liability under this limited warranty exceed the purchase price paid for the product, and any legal actions brought against Woodstock International, Inc. shall be tried in the State of Washington, County of Whatcom. We shall in no event be liable for death, injuries to persons or property or for incidental, contingent, special or consequential damages arising from the use of our products.

Every effort has been made to ensure that all Shop Fox machinery meets high quality and durability standards. We are committed to continuously improving the quality of our products, and reserve the right to change specifications at any time.



High Quality Machines and Tools

Woodstock International, Inc. carries thousands of products designed to meet the needs of today's woodworkers and metalworkers.

Ask your dealer about these fine products:

BROSWA
PRECISION STOP BLOCK

JOINTER PAL[®]

Rotacator[®]

THE REBEL[®]

DURASTICK[®]

Gutmann[®]

BOARD BUDDIES[®]

Junglee[®]

PLANER PAL[®]



PARROT VISE[®]

SLICKPLANE[®]

PRO-STIK[®]
ABRASIVE BELT & DISC CLEANER

ACCU-SHARP[®]



STEELEX[®]
PLUS

STEELEX[®]
FINE TOOLS

Aluma-Classic[®]

WHOLESALE ONLY

WOODSTOCK INTERNATIONAL, INC.

Phone: (360) 734-3482 • Fax: (360) 671-3053 • Toll Free Fax: (800) 647-8801

P.O.Box 2309 • Bellingham, WA 98227

SHOPFOX.BIZ