



**MODEL W1851**  
**10" HYBRID TABLE SAW**  
**w/EXTENSION TABLE**



**OWNER'S MANUAL**  
*(FOR MODELS MANUFACTURED SINCE 10/17)*

Phone: (360) 734-3482 • Online Technical Support: [techsupport@woodstockint.com](mailto:techsupport@woodstockint.com)

COPYRIGHT © JULY, 2017 BY WOODSTOCK INTERNATIONAL, INC. REVISED APRIL, 2018 (JH)

WARNING: NO PORTION OF THIS MANUAL MAY BE REPRODUCED IN ANY SHAPE OR FORM WITHOUT

THE WRITTEN APPROVAL OF WOODSTOCK INTERNATIONAL, INC.

#19122BL Printed in China



## **WARNING!**

This manual provides critical safety instructions on the proper setup, operation, maintenance, and service of this machine/tool. Save this document, refer to it often, and use it to instruct other operators.

Failure to read, understand and follow the instructions in this manual may result in fire or serious personal injury—including amputation, electrocution, or death.

The owner of this machine/tool is solely responsible for its safe use. This responsibility includes but is not limited to proper installation in a safe environment, personnel training and usage authorization, proper inspection and maintenance, manual availability and comprehension, application of safety devices, cutting/sanding/grinding tool integrity, and the usage of personal protective equipment.

The manufacturer will not be held liable for injury or property damage from negligence, improper training, machine modifications or misuse.



## **WARNING!**

Some dust created by power sanding, sawing, grinding, drilling, and other construction activities contains chemicals known to the State of California to cause cancer, birth defects or other reproductive harm. Some examples of these chemicals are:

- Lead from lead-based paints.
- Crystalline silica from bricks, cement and other masonry products.
- Arsenic and chromium from chemically-treated lumber.

Your risk from these exposures varies, depending on how often you do this type of work. To reduce your exposure to these chemicals: Work in a well ventilated area, and work with approved safety equipment, such as those dust masks that are specially designed to filter out microscopic particles.

# Contents

|  |           |   |           |
|--|-----------|---|-----------|
| <b>INTRODUCTION</b> .....                    | <b>2</b>  | <b>SHOP-MADE SAFETY ACCESSORIES</b> ..... | <b>55</b> |
| Contact Info.....                            | 2         | Featherboards .....                       | 55        |
| Manual Accuracy.....                         | 2         | Push Sticks .....                         | 58        |
| Controls & Components .....                  | 7         | Push Blocks.....                          | 59        |
| <b>SAFETY</b> .....                          | <b>8</b>  | Narrow-Rip Auxiliary Fence & Push Block.. | 60        |
| Standard Machinery Safety Instructions ..... | 8         | Outfeed & Support Tables .....            | 62        |
| Additional Safety for Table Saws .....       | 10        | Crosscut Sled.....                        | 62        |
| Preventing Kickback .....                    | 11        | <b>ACCESSORIES</b> .....                  | <b>63</b> |
| Protecting Yourself From Kickback .....      | 11        | Table Saw Accessories .....               | 63        |
| Glossary of Terms .....                      | 12        | <b>MAINTENANCE</b> .....                  | <b>66</b> |
| <b>ELECTRICAL</b> .....                      | <b>13</b> | General .....                             | 66        |
| Circuit Requirements .....                   | 13        | Cleaning & Protecting .....               | 66        |
| Grounding Requirements.....                  | 14        | Lubrication .....                         | 67        |
| Extension Cords .....                        | 14        | <b>SERVICE</b> .....                      | <b>68</b> |
| Converting Voltage to 115V .....             | 15        | General .....                             | 68        |
| <b>SETUP</b> .....                           | <b>16</b> | Blade Tilt Stops.....                     | 68        |
| Unpacking .....                              | 16        | Miter Slot to Blade Parallelism.....      | 70        |
| Items Needed for Setup.....                  | 16        | Spreader or Riving Knife Alignment .....  | 72        |
| Inventory .....                              | 17        | Fence Adjustments.....                    | 74        |
| Hardware Recognition Chart .....             | 19        | Fence Scale Calibration .....             | 77        |
| Cleaning Machine.....                        | 20        | Table/Dado Insert Adjustment .....        | 78        |
| Machine Placement .....                      | 21        | Miter Gauge Adjustments .....             | 79        |
| Assembly.....                                | 22        | Belt Tension & Replacement .....          | 80        |
| Dust Collection .....                        | 28        | Troubleshooting.....                      | 81        |
| Test Run.....                                | 29        | Electrical Safety Instructions.....       | 83        |
| <b>OPERATIONS</b> .....                      | <b>30</b> | Electrical Components .....               | 84        |
| General .....                                | 30        | Wiring Diagram .....                      | 85        |
| Workpiece Inspection.....                    | 31        | <b>PARTS</b> .....                        | <b>86</b> |
| Non-Through & Through Cuts .....             | 32        | Body .....                                | 86        |
| Blade Size Requirements.....                 | 33        | Trunnion .....                            | 87        |
| Blade Selection .....                        | 33        | Power Switch .....                        | 89        |
| Blade Installation .....                     | 35        | Blade Guard .....                         | 90        |
| Blade Guard Assembly .....                   | 37        | Miter Guage .....                         | 91        |
| Riving Knife .....                           | 40        | Fence.....                                | 92        |
| Ripping .....                                | 41        | Fence Rails .....                         | 93        |
| Crosscutting.....                            | 42        | Labels & Cosmetics .....                  | 94        |
| Miter Cuts .....                             | 43        | <b>WARRANTY</b> .....                     | <b>97</b> |
| Miter Fence .....                            | 43        |   |           |
| Flip Stop .....                              | 44        |   |           |
| Blade Tilt/Bevel Cuts.....                   | 44        |   |           |
| Dado Cutting .....                           | 45        |   |           |
| Rabbit Cutting .....                         | 48        |   |           |
| Resawing.....                                | 50        |   |           |





# INTRODUCTION

## Contact Info

We are committed to customer satisfaction. If you have any questions or need help, use the information below to contact us.

**IMPORTANT: Before contacting, please get the original purchase receipt, serial number, and manufacture date of your machine. This information is required for all Technical Support calls and it will help us help you faster.**

Woodstock International Technical Support  
 Phone: (360) 734-3482  
 Email: techsupport@woodstockint.com

We want your feedback on this manual. What did you like about it? Where could it be improved? Please take a few minutes to give us feedback.

Technical Documentation Manager  
 P.O. Box 2309  
 Bellingham, WA 98227  
 Email: manuals@woodstockint.com

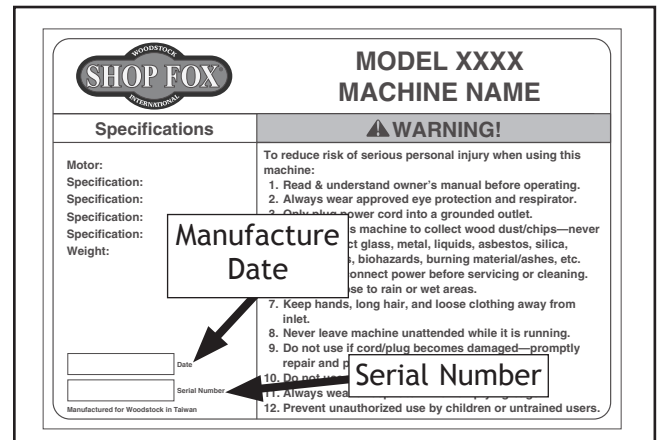
## Manual Accuracy

We are proud to provide a high-quality owner's manual with your new machine!

We made every effort to be exact with the instructions, specifications, drawings, and photographs contained inside. Sometimes we make mistakes, but our policy of continuous improvement also means that **sometimes the machine you receive will be slightly different than what is shown in the manual.**

If you find this to be the case, and the difference between the manual and machine leaves you confused about a procedure, check our website for an updated version. We post current manuals and manual updates for free on our website at [www.woodstockint.com](http://www.woodstockint.com).

Alternatively, you can call our Technical Support for help. Before calling, make sure you write down the **Manufacture Date** and **Serial Number** from the machine ID label (see below). Also, if available, have a copy of your **original purchase receipt** on hand. This information is required for all Tech Support calls.





# MACHINE SPECIFICATIONS



© Woodstock International, Inc. • Phone: (800) 840-8420 • Web: www.shopfox.biz

## MODEL W1851 2 HP 10" HYBRID CABINET TABLE SAW WITH EXTENSION TABLE

### Product Dimensions

Weight..... 410 lbs.  
 Width (side-to-side) x Depth (front-to-back) x Height..... 68 x 39 x 47-3/4 in.  
 Footprint (Length x Width)..... 20-1/2 x 19-1/2 in.

### Shipping Dimensions

#### Carton #1

Type..... Cardboard Box on Wood Skids  
 Content..... Machine  
 Weight..... 404 lbs.  
 Length x Width x Height..... 30 x 25 x 42 in.  
 Must Ship Upright..... Yes

#### Carton #2

Type..... Cardboard Box  
 Content..... Fence  
 Weight..... 21 lbs.  
 Length x Width x Height..... 37 x 15 x 7 in.  
 Must Ship Upright..... No

#### Carton #3

Type..... Cardboard Box  
 Content..... Rails  
 Weight..... 33 lbs.  
 Length x Width x Height..... 64 x 6 x 4 in.  
 Must Ship Upright..... No

### Electrical

Power Requirement..... 115V or 230V, Single-Phase, 60 Hz  
 Prewired Voltage..... 230V  
 Full-Load Current Rating..... 16A at 115V, 8A at 230V  
 Minimum Circuit Size..... 20A at 115V, 15A at 230V  
 Connection Type..... Cord & Plug  
 Power Cord Included..... Yes  
 Power Cord Length..... 6 ft.  
 Power Cord Gauge..... 14 AWG  
 Plug Included..... Yes  
 Included Plug Type..... 6-20 for 230V  
 Recommended Plug Type..... 5-20 for 115V  
 Switch Type..... START/STOP Push Button w/Large Shut-Off Paddle & Disabling Pin  
 Voltage Conversion Kit..... X1851224X for 115V



**Motors**

**Main**

|                      |                                   |
|----------------------|-----------------------------------|
| Horsepower.....      | 2 HP                              |
| Phase.....           | Single-Phase                      |
| Amps.....            | 16A/8A                            |
| Speed.....           | 3450 RPM                          |
| Type.....            | TEFC Capacitor-Start Induction    |
| Power Transfer ..... | Belt Drive                        |
| Bearings.....        | Shielded & Permanently Lubricated |

**Main Specifications**

**Main Information**

|  |            |
|--|------------|
| Table Saw Type.....                                  | Hybrid     |
| Maximum Blade Diameter.....                          | 10 in.     |
| Arbor Size.....                                      | 5/8 in.    |
| Arbor Speed.....                                     | 3850 RPM   |
| Maximum Width of Dado.....                           | 13/16 in.  |
| Blade Tilt Direction.....                            | Left       |
| Max Blade Tilt.....                                  | 45 deg.    |
| Maximum Depth of Cut At 90 Degrees.....              | 3-1/8 in.  |
| Maximum Depth of Cut At 45 Degrees.....              | 2-3/16 in. |
| Max Rip Right of Blade w/Included Fence & Rails..... | 31-1/2 in. |
| Max Rip Left of Blade w/Included Fence & Rails.....  | 11-3/8 in. |

**Additional Blade Information**

|                                      |                   |
|--------------------------------------|-------------------|
| Included Blade Information.....      | 10" x 40T         |
| Riving Knife/Spreader Thickness..... | 0.1 in.           |
| Required Blade Body Thickness.....   | 0.063 - 0.094 in. |
| Required Blade Kerf Thickness.....   | 0.102 - 0.126 in. |
| Rim Speed at Max Blade Diameter..... | 10,074 FPM        |

**Table Information**

|  |            |
|--|------------|
| Floor to Table Height.....                           | 34-1/4 in. |
| Table Size with Extension Wings Width.....           | 40 in.     |
| Table Size with Extension Wings Depth.....           | 27 in.     |
| Distance Front of Table to Center of Blade.....      | 16-1/4 in. |
| Distance Front of Table to Blade At Maximum Cut..... | 11-1/2 in. |
| Main Table Size Thickness.....                       | 1-1/2 in.  |

**Fence Information**

|                        |   |
|------------------------|---|
| Fence Type.....        | Camlock T-Shape w/High-Low Profile Face |
| Fence Size Length..... | 34-5/8 in.                              |
| Fence Size Width.....  | 4-5/8 in.                               |
| Fence Size Height..... | 3 in.                                   |
| Fence Rail Type.....   | Square Steel Tubing/Angle Iron          |
| Fence Rail Length..... | 61-7/8 in.                              |
| Fence Rail Width.....  | 2 in.                                   |
| Fence Rail Height..... | 1-5/8 in.                               |

**Miter Gauge Information**

|                                   |         |
|-----------------------------------|---------|
| Miter Gauge Slot Type.....        | T-Slot  |
| Miter Gauge Slot Size Width.....  | 3/4 in. |
| Miter Gauge Slot Size Height..... | 3/8 in. |

**Construction**

|                                     |                             |
|-------------------------------------|-----------------------------|
| Table.....                          | Precision-Ground Cast Iron  |
| Wings.....                          | Precision-Ground Cast Iron  |
| Cabinet.....                        | Pre-Formed Steel            |
| Trunnions.....                      | Cast Iron                   |
| Fence Assembly.....                 | Steel w/Aluminum Fence      |
| Rails.....                          | Steel                       |
| Miter Guage Construction.....       | Cast Iron                   |
| Guard.....                          | Clear Plastic               |
| Body/Cabinet Paint Type/Finish..... | Powder Coated               |
| Arbor Bearings.....                 | Sealed & Permanently Sealed |

**Other Related Information**

|                             |              |
|-----------------------------|--------------|
| Number of Dust Ports.....   | 2            |
| Dust Port Size.....         | 4, 1-1/2 in. |
| Compatible Mobile Base..... | D2057A       |

**Other**

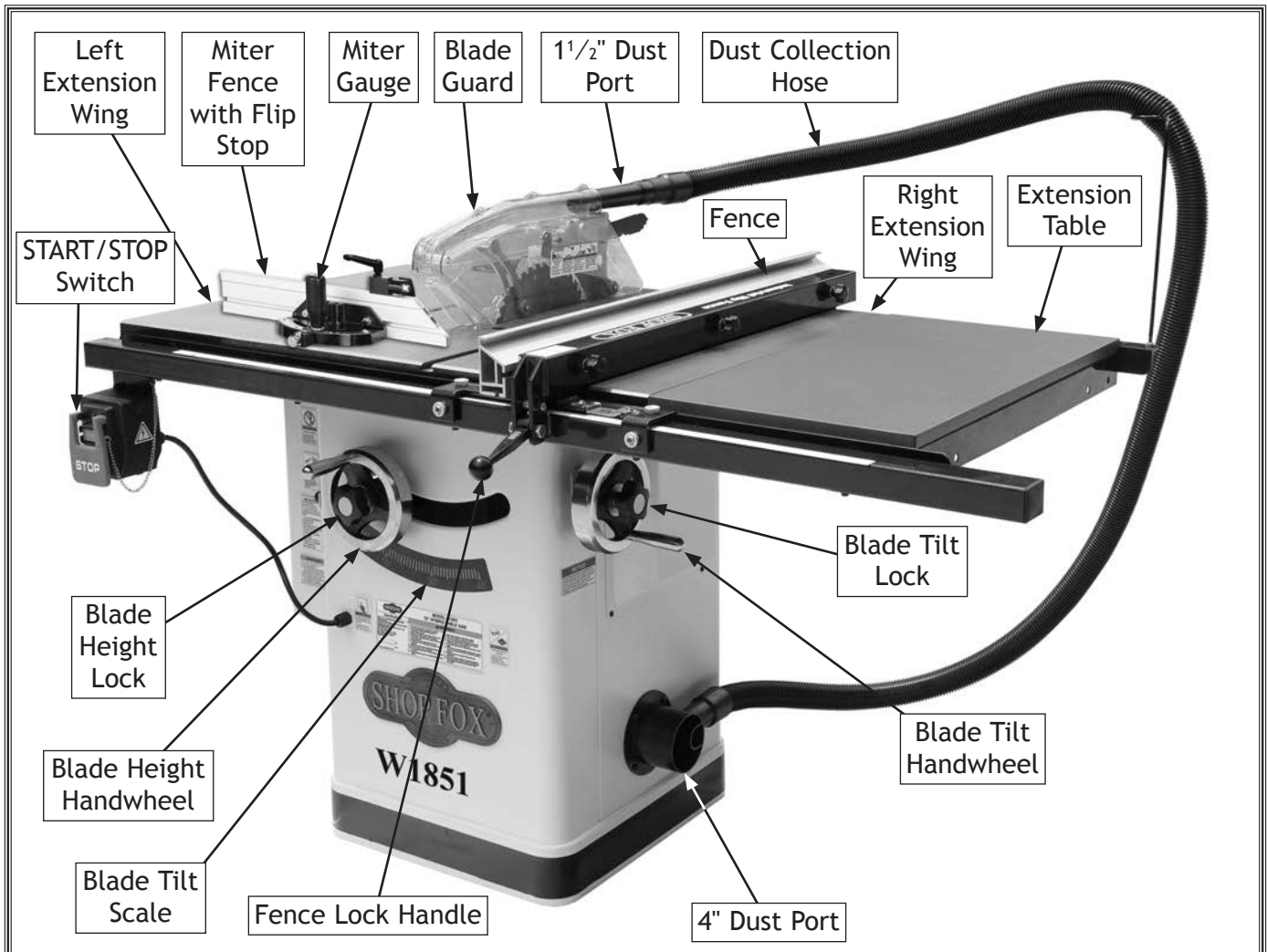
|  |          |
|--|----------|
| Country of Origin .....  | China    |
| Warranty .....   | 2 Years  |
| Approximate Assembly & Setup Time .....                              | 1 Hour   |
| Serial Number Location .....   | ID Label |
| Sound Rating .....   | 87 dB    |
| ISO 9001 Factory .....   | Yes      |
| Certified by a Nationally Recognized Testing Laboratory (NRTL) ..... | No       |

**Features**

- Fully-Enclosed, Quick-Release Blade Guard and Spreader
- Quick-Release Riving Knife
- Zinc Alloy Hinged Motor Cover
- 4" & 1-1/2" Dust Ports
- Heavy Cast Handwheels
- T-Slot Miter Gauge with Fence Extension and Flip Stops
- Poly-V Serpentine Drive Belt System for Reduced Noise/Vibration
- Precision-Ground Cast-Iron Table
- Large Cabinet-Mounted, Cast-Iron Trunnions
- Durable Powder-Coated Finish
- Deluxe 2-Position (High-Low) Aluminum Rip Fence
- Easy-Glide Fence System with Added Micro-Adjustment Controls
- Standard & Dado Table Inserts
- Built-In Dust Port on Blade Guard
- Included 10" x 40T Carbide-Tipped Blade

# Identification

Become familiar with the names and locations of the controls and features shown below to better understand the instructions in this manual.



## ⚠ CAUTION

For Your Own Safety Read Instruction Manual Before Operating Saw

- a) Wear eye protection.
- b) Use saw-blade guard and spreader for every operation for which it can be used, including all through sawing.
- c) Keep hands out of the line of saw blade.
- d) Use a push-stick when required.
- e) Pay particular attention to instructions on reducing risk of kickback.
- f) DO NOT perform any operation freehand.
- g) Never reach around or over saw blade.

# Controls & Components

Refer to Figures 1-4 and the following descriptions to become familiar with the basic controls of this machine.

A. **START/STOP Switch:** Starts and stops the motor. The switch can be disabled for safety by inserting the disabling pin or a padlock (not included) through the START button.

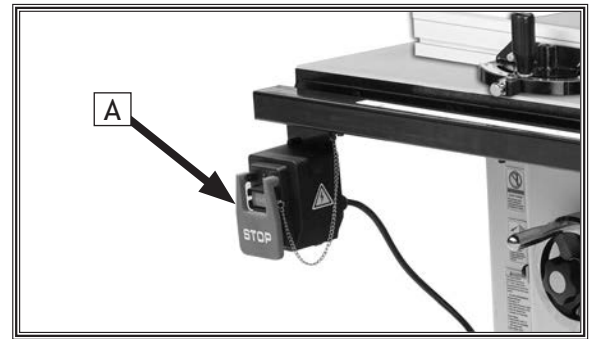


Figure 1. Location of START/STOP switch.

B. **Handwheel Locks:** Lock blade height and angle when tightened (one on each handwheel).

C. **Blade Height Handwheel:** Adjusts blade height from 0"-3<sup>1</sup>/<sub>8</sub>".

D. **Blade Tilt Handwheel:** Adjusts angle of blade tilt from 90°-45°.

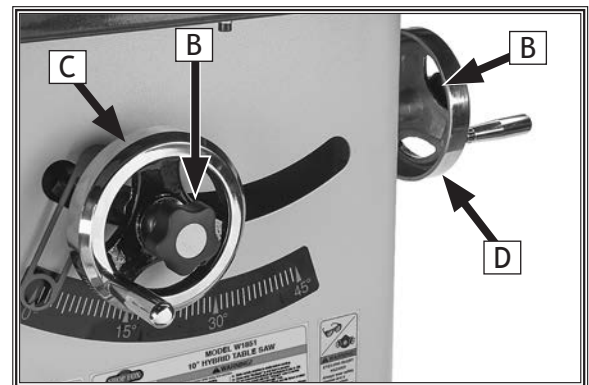


Figure 2. Blade adjustment handwheels and locks.

E. **Fence Lock Handle:** Locks fence when pushed down, unlocks fence when pulled up.

F. **Fence:** Guides workpiece as it moves into blade and determines angle of cut. Fence face can be positioned for standard cutting operations, or placed in lower position for blade guard clearance during narrow ripping operations.

G. **Fence Lock Knobs:** Secure fence when tightened; allow fence to be repositioned along fence tube when loosened.

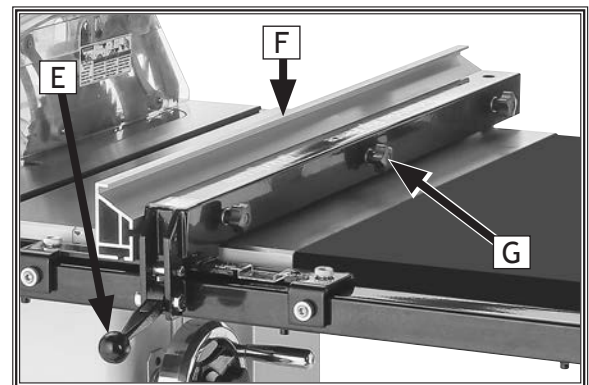


Figure 3. Location of fence controls.

H. **Miter Fence:** Provides greater workpiece support than the miter gauge alone, especially for longer workpieces.

I. **Miter Gauge:** Guides workpiece into blade at a set angle along one of two miter slots in table.

J. **Flip Stop:** Used to perform repeatable cuts with the miter fence and can be positioned anywhere along miter fence.

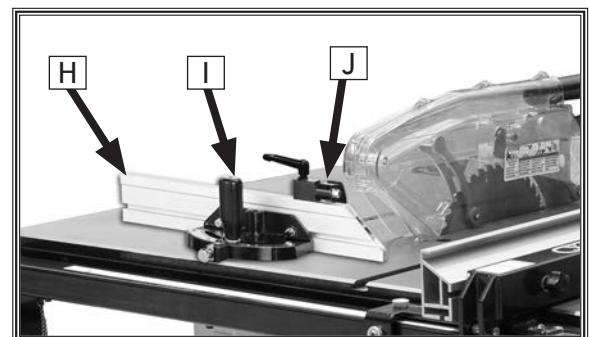


Figure 4. Miter fence and miter gauge.

# SAFETY

## For Your Own Safety, Read Manual Before Operating Machine

The purpose of safety symbols is to attract your attention to possible hazardous conditions. This manual uses a series of symbols and signal words intended to convey the level of importance of the safety messages. The progression of symbols is described below. Remember that safety messages by themselves do not eliminate danger and are not a substitute for proper accident prevention measures—this responsibility is ultimately up to the operator!



Indicates an imminently hazardous situation which, if not avoided, **WILL** result in death or serious injury.



Indicates a potentially hazardous situation which, if not avoided, **COULD** result in death or serious injury.



Indicates a potentially hazardous situation which, if not avoided, **MAY** result in minor or moderate injury.

### **NOTICE**

This symbol is used to alert the user to useful information about proper operation of the equipment or a situation that may cause damage to the machinery.

## Standard Machinery Safety Instructions

**OWNER'S MANUAL.** Read and understand this owner's manual **BEFORE** using machine.

**TRAINED OPERATORS ONLY.** Untrained operators have a higher risk of being hurt or killed. Only allow trained/supervised people to use this machine. When machine is not being used, disconnect power, remove switch keys, or lock-out machine to prevent unauthorized use—especially around children. Make workshop kid proof!

**DANGEROUS ENVIRONMENTS.** Do not use machinery in areas that are wet, cluttered, or have poor lighting. Operating machinery in these areas greatly increases the risk of accidents and injury.

**MENTAL ALERTNESS REQUIRED.** Full mental alertness is required for safe operation of machinery. Never operate under the influence of drugs or alcohol, when tired, or when distracted.

**ELECTRICAL EQUIPMENT INJURY RISKS.** You can be shocked, burned, or killed by touching live electrical components or improperly grounded machinery. To reduce this risk, only allow an electrician or qualified service personnel to do electrical installation or repair work, and always disconnect power before accessing or exposing electrical equipment.

**DISCONNECT POWER FIRST.** Always disconnect machine from power supply **BEFORE** making adjustments, changing tooling, or servicing machine. This eliminates the risk of injury from unintended startup or contact with live electrical components.

**EYE PROTECTION.** Always wear ANSI-approved safety glasses or a face shield when operating or observing machinery to reduce the risk of eye injury or blindness from flying particles. Everyday eyeglasses are not approved safety glasses.

**WEARING PROPER APPAREL.** Do not wear clothing, apparel, or jewelry that can become entangled in moving parts. Always tie back or cover long hair. Wear non-slip footwear to avoid accidental slips, which could cause loss of workpiece control.

**HAZARDOUS DUST.** Dust created while using machinery may cause cancer, birth defects, or long-term respiratory damage. Be aware of dust hazards associated with each workpiece material, and always wear a NIOSH-approved respirator to reduce your risk.

**HEARING PROTECTION.** Always wear hearing protection when operating or observing loud machinery. Extended exposure to this noise without hearing protection can cause permanent hearing loss.

**REMOVE ADJUSTING TOOLS.** Tools left on machinery can become dangerous projectiles upon startup. Never leave chuck keys, wrenches, or any other tools on machine. Always verify removal before starting!

**INTENDED USAGE.** Only use machine for its intended purpose—never make modifications without prior approval from Woodstock International. Modifying machine or using it differently than intended will void the warranty and may result in malfunction or mechanical failure that leads to serious personal injury or death!

**AWKWARD POSITIONS.** Keep proper footing and balance at all times when operating machine. Do not overreach! Avoid awkward hand positions that make workpiece control difficult or increase the risk of accidental injury.

**CHILDREN & BYSTANDERS.** Keep children and bystanders at a safe distance from the work area. Stop using machine if they become a distraction.

**GUARDS & COVERS.** Guards and covers reduce accidental contact with moving parts or flying debris—make sure they are properly installed, undamaged, and working correctly.

**FORCING MACHINERY.** Do not force machine. It will do the job safer and better at the rate for which it was designed.

**NEVER STAND ON MACHINE.** Serious injury may occur if machine is tipped or if the cutting tool is unintentionally contacted.

**STABLE MACHINE.** Unexpected movement during operation greatly increases risk of injury or loss of control. Before starting, verify machine is stable and mobile base (if used) is locked.

**USE RECOMMENDED ACCESSORIES.** Consult this owner's manual or the manufacturer for recommended accessories. Using improper accessories will increase risk of serious injury.

**UNATTENDED OPERATION.** To reduce the risk of accidental injury, turn machine **OFF** and ensure all moving parts completely stop before walking away. Never leave machine running while unattended.

**MAINTAIN WITH CARE.** Follow all maintenance instructions and lubrication schedules to keep machine in good working condition. A machine that is improperly maintained could malfunction, leading to serious personal injury or death.

**CHECK DAMAGED PARTS.** Regularly inspect machine for any condition that may affect safe operation. Immediately repair or replace damaged or mis-adjusted parts before operating machine.

**MAINTAIN POWER CORDS.** When disconnecting cord-connected machines from power, grab and pull the plug—NOT the cord. Pulling the cord may damage the wires inside, resulting in a short. Do not handle cord/plug with wet hands. Avoid cord damage by keeping it away from heated surfaces, high traffic areas, harsh chemicals, and wet/damp locations.

**EXPERIENCING DIFFICULTIES.** If at any time you experience difficulties performing the intended operation, stop using the machine! Contact Technical Support at (360) 734-3482.

# Additional Safety for Table Saws

## WARNING

Serious cuts, amputation, or death can occur from contact with rotating saw blade during operation. Workpieces, broken blades, or flying particles thrown by blade can blind or strike operators or bystanders with deadly force. To reduce the risk of these hazards, operator and bystanders **MUST** completely heed the hazards and warnings below.

**HAND & BODY POSITIONING.** Keep hands away from saw blade and out of blade path during operation, so they cannot accidentally slip into blade. Only operate at front of machine and always stand to side of blade path. Never reach behind or over blade.

**BLADE GUARD.** The blade guard protects operator from rotating saw blade. Make sure blade guard is installed, adjusted correctly, and used for all possible “through cuts.” Promptly repair or replace if damaged. Re-install immediately after operations that require its removal.

**RIVING KNIFE.** Use riving knife for all “non-through cuts.” Make sure it is aligned and positioned correctly. Promptly repair or replace it if damaged.

**KICKBACK.** Kickback occurs when saw blade ejects workpiece back toward operator. Know how to reduce risk of kickback, and learn how to protect yourself if it does occur.

**FEEDING WORKPIECE.** Feeding workpiece incorrectly increases risk of kickback. Always allow blade to reach full speed before cutting, feed workpiece from front of saw, making sure workpiece is flat against table and a fence, miter gauge, or other guide is used to feed workpiece in a straight line. Feed cuts through to completion. Never start saw with workpiece touching blade or pull workpiece from behind blade. Never back workpiece out of cut, move it sideways, or perform a “freehand” operation. Never plunge cut.

**PUSH STICKS/PUSH BLOCKS.** To reduce risk of accidental blade contact, use push sticks/push blocks whenever possible. In event of an accident, these will often take damage that would have occurred to hands/fingers.

**FENCE.** To reduce risk of kickback, make sure fence remains properly adjusted and parallel with blade. Always lock fence before using.

**CUT-OFF PIECES.** To avoid risk of injury due to blade contact, turn saw **OFF** and allow blade to completely stop before removing cut-off pieces near blade or trapped between blade and table insert. Never use your hands to move cut-off pieces away from blade while saw is running.

**BLADE ADJUSTMENTS.** Adjusting blade height or tilt during operation increases risk of crashing blade and sending metal fragments flying with deadly force at operator or bystanders. Only adjust blade height and tilt when blade is completely stopped and saw is **OFF**.

**CHANGING BLADES.** Accidental startup while changing saw blade can result in serious injury. To reduce risk of accidental blade contact, always disconnect power before changing blades.

**DAMAGED SAW BLADES.** Damaged saw blade teeth can become deadly projectiles. Never use blades that have been dropped or damaged.

**DADO AND RABBET OPERATIONS.** Dado and rabbeting operations require special attention since they must be performed with blade guard removed, which increases risk of blade contact. **DO NOT** attempt dado or rabbeting operations without first reading these sections in this manual.

**CUTTING CORRECT MATERIAL.** Cutting metal, glass, stone, tile, etc., increases risk of operator injury due to kickback or flying particles. Only cut natural and man-made wood products, laminate-covered wood products, and some plastics. Never cut materials not intended for this saw.

# Preventing Kickback

Below are ways to avoid the most common causes of kickback:

- Only cut workpieces with at least one smooth and straight edge. DO NOT cut warped, cupped or twisted wood.
- Keep the blade guard installed and working correctly for all through-cuts.
- Never attempt freehand cuts. If the workpiece is not fed parallel with the blade, kickback will likely occur. Always use the rip fence or miter gauge to support the workpiece.
- Make sure the spreader or riving knife is aligned with the blade. A misaligned spreader or riving knife can cause the workpiece to catch or bind, increasing the chance of kickback.
- Take the time to check and adjust the rip fence parallel with the blade; otherwise, the chances of kickback are extreme.
- The spreader or riving knife maintains the kerf in the workpiece, reducing the chance of kickback. Always use the riving knife for all non-through operations, unless using with dado blade smaller than 10" in diameter. Always use the spreader with the blade guard for all through cuts.
- Feed cuts through to completion. Anytime you stop feeding a workpiece in the middle of a cut, the chance of kickback is greatly increased.
- Keep the blade guard installed and in good working order. Only remove it when performing non-through cuts and immediately re-install the blade guard when finished. Remember, always use the riving knife for all non-through operations, unless a dado blade is installed.
- Make multiple, shallow passes when performing a non-through cut. Making a deep non-through cut will greatly increase the chance of kickback.

- Never move the workpiece backwards or try to back it out of a cut while the blade is moving. If you cannot complete a cut for some reason, stop the saw motor and allow the blade to completely stop before backing the workpiece out. Promptly fix the condition that prevented you from completing the cut before starting the saw again.

# Protecting Yourself From Kickback

Even if you know how to prevent kickback, it may still happen. Here are some ways to protect yourself if kickback DOES occur:

- Stand to the side of the blade during every cut. If kickback does occur, the thrown workpiece usually travels directly in front of the blade.
- Wear safety glasses or a face shield. In the event of kickback, your eyes and face are the most vulnerable parts of your body.
- Never, for any reason, place your hand behind the blade. Should kickback occur, your hand will be pulled into the blade, which could cause amputation.
- Use a push stick to keep your hands farther away from the moving blade. If kickback occurs, the push stick will most likely take the damage your hand would have received.
- Use featherboards or anti-kickback devices to assist with feeding and prevent or slow down kickback.

## CAUTION

Statistics show that most common accidents among table saw users can be linked to kickback. Kickback is typically defined as the high-speed expulsion of stock from the table saw toward its operator. In addition to the danger of the operator or others in the area being struck by the flying stock, it is often the case that the operator's hands are pulled into the blade during kickback.

# Glossary of Terms

The following is a list of common definitions, terms and phrases used throughout this manual as they relate to this table saw and woodworking in general. Become familiar with these terms for assembling, adjusting or operating this machine.

SAFETY

**Arbor:** A metal shaft extending from the drive mechanism that is the mounting location for the saw blade.

**Bevel Edge Cut:** A cut made with the blade tilted to an angle between 0° and 45° to cut a beveled edge onto a workpiece. Refer to **Page 44** for more details.

**Blade Guard Assembly:** Metal or plastic safety device that mounts over the saw blade. Its function is to prevent the operator from coming into contact with the saw blade. Refer to **Page 37** for more details.

**Crosscut:** Cutting operation in which the cross-cut fence is used to cut across the shortest width of the workpiece. Refer to **Page 42** for more details.

**Dado Blade:** Blade or set of blades that are used to cut grooves and rabbets. Refer to **Page 45** for more details. The saw and arbor are not intended to safely use a larger dado blade.

**Dado Cut:** Cutting operation that uses a dado blade to cut a flat bottomed groove into the face of the workpiece. Refer to **Page 45** for more details.

**Featherboard:** Safety device used to keep the workpiece against the rip fence and against the table surface. Refer to **Page 55** for more details.

**Kerf:** The resulting cut or gap in the workpiece after the saw blade passes through during a cutting operation.

**Kickback:** An event in which the workpiece is propelled back towards the operator at a high rate of speed.

**Non-Through Cut:** A cut in which the blade does not cut through the top of the workpiece. Refer to **Page 32** for more details.

**Parallel:** Being an equal distance apart at every point along two given lines or planes (i.e. the rip fence face is parallel to the face of the saw blade).

**Perpendicular:** Lines or planes that intersect and form right angles (i.e. the blade is perpendicular to the table surface).

**Push Stick:** Safety device used to push the workpiece through a cutting operation. Used most often when rip cutting thin workpieces. Refer to **Page 58** for more details.

**Rabbet:** Cutting operation that creates an L-shaped channel along the edge of the workpiece. Refer to **Page 48** for more details.

**Rip Cut:** Cutting operation in which the rip fence is used to cut across the widest width of the workpiece. Refer to **Page 41** for more details.

**Riving Knife:** Metal plate located behind the blade. It maintains the kerf opening in the wood when performing a cutting operation. Refer to **Page 40** for more details.

**Straightedge:** A tool used to check the flatness, parallelism, or consistency of a surface(s).

**Thin Kerf Blade:** A blade with a kerf or thickness that is thinner than a standard blade cannot be used on this saw.

**Through Cut:** A cut in which the blade cuts completely through the workpiece. Refer to **Page 32** for more details.

# ELECTRICAL

## Circuit Requirements

This machine must be connected to the correct size and type of power supply circuit, or fire or electrical damage may occur. Read through this section to determine if an adequate power supply circuit is available. If a correct circuit is not available, a qualified electrician **MUST** install one before you can connect the machine to power.

A power supply circuit includes all electrical equipment between the breaker box or fuse panel in the building and the machine. The power supply circuit used for this machine must be sized to safely handle the full-load current drawn from the machine for an extended period of time. (If this machine is connected to a circuit protected by fuses, use a time delay fuse marked D.)

### Full-Load Current Rating

The full-load current rating is the amperage a machine draws at 100% of the rated output power. On machines with multiple motors, this is the amperage drawn by the largest motor or sum of all motors and electrical devices that might operate at one time during normal operations.

Full-Load Current Rating at 230V .....8 Amps  
Full-Load Current Rating at 115V ..... 16 Amps

### Circuit Requirements for 230V (Prewired)

This machine is prewired to operate on a power supply circuit that has a verified ground and meets the following requirements:

Circuit Type .....220V/240V, 60 Hz, Single-Phase  
Circuit Size ..... 15 Amps  
Plug/Receptacle ..... NEMA 6-20

### Circuit Requirements for 115V


This machine can be converted to operate on a power supply circuit that has a verified ground and meets the requirements listed below. (Refer to **Voltage Conversion** instructions for details.)

Circuit Type ..... 110V/120V, 60 Hz, Single-Phase  
Circuit Size ..... 20 Amps  
Plug/Receptacle ..... NEMA 5-20

**⚠ WARNING**

The machine must be properly set up before it is safe to operate. **DO NOT** connect this machine to the power source until instructed to do so later in this manual.

**⚠ WARNING**



Incorrectly wiring or grounding this machine can cause electrocution, fire, or machine damage. To reduce this risk, only an electrician or qualified service personnel should do any required electrical work on this machine.

**NOTICE**

The circuit requirements listed in this manual apply to a dedicated circuit—where only one machine will be running at a time. If this machine will be connected to a shared circuit where multiple machines will be running at the same time, consult with an electrician to ensure that the circuit is properly sized for safe operation.

ELECTRICAL

# Grounding Requirements

This machine **MUST** be grounded. In the event of certain types of malfunctions or breakdowns, grounding provides a path of least resistance for electric current to travel—in order to reduce the risk of electric shock.

Improper connection of the equipment-grounding wire will increase the risk of electric shock. The wire with green insulation (with/without yellow stripes) is the equipment-grounding wire. If repair or replacement of the power cord or plug is necessary, do not connect the equipment-grounding wire to a live (current carrying) terminal.

Check with a qualified electrician or service personnel if you do not understand these grounding requirements, or if you are in doubt about whether the tool is properly grounded. If you ever notice that a cord or plug is damaged or worn, disconnect it from power, and immediately replace it with a new one.

## For 230V Connection (Prewired)

This machine is equipped with a power cord that has an equipment-grounding wire and NEMA 6-15 grounding plug (see figure). The plug must only be inserted into a matching receptacle that is properly installed and grounded in accordance with local codes and ordinances.

## For 115V Connection (Must be Rewired)

A NEMA 5-20 plug (see figure) has a grounding prong that must be attached to the equipment-grounding wire inside the included power cord. The plug must only be inserted into a matching receptacle that is properly installed and grounded in accordance with all local codes and ordinances.

# Extension Cords

We do not recommend using an extension cord with this machine. Extension cords cause voltage drop, which may damage electrical components and shorten motor life. Voltage drop increases with longer extension cords and smaller gauge sizes (higher gauge numbers indicate smaller sizes).

Any extension cord used with this machine must contain a ground wire, match the required plug and receptacle, and meet the following requirements:

- Minimum Gauge Size at 220V ..... 12 AWG
- Maximum Length (Shorter is Better) ..... 50 ft.

ELECTRICAL

**⚠ WARNING**

The machine must be properly set up before it is safe to operate. **DO NOT** connect this machine to the power source until instructed to do so later in this manual.

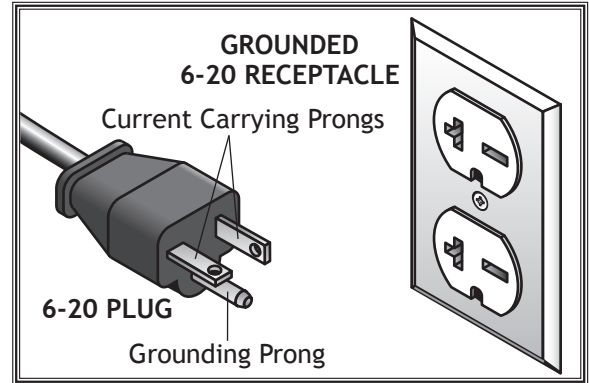


Figure 5. NEMA 6-20 plug & receptacle.

**⚠ CAUTION**

No adapter should be used with the required plug. If the plug does not fit the available receptacle or the machine must be reconnected to a different type of circuit, the reconnection must be made by an electrician or qualified service personnel and it must comply with all local codes and ordinances.

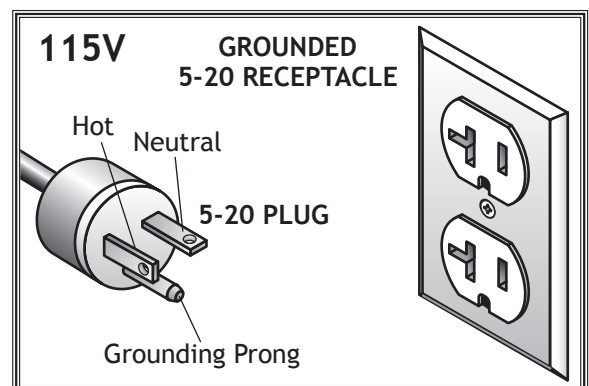


Figure 6. NEMA 5-20 plug & receptacle.

# Converting Voltage to 115V

The voltage conversion MUST be performed by an electrician or qualified service personnel.

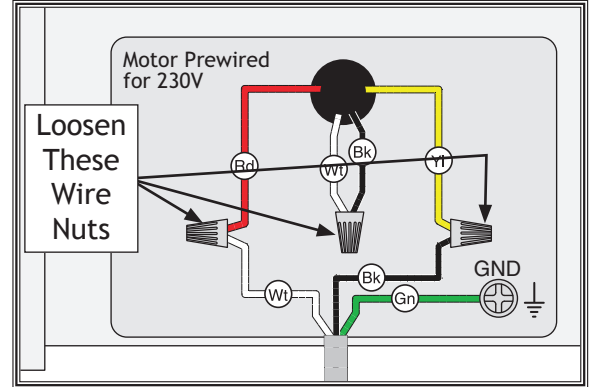
The voltage conversion procedure consists of rewiring the motor and installing the correct plug. A wiring diagram is provided on **Page 85** for your reference.

**IMPORTANT:** *If the diagram included on the motor conflicts with the one on **Page 85**, the motor may have changed since the manual was printed. Use the diagram included on the motor instead.*

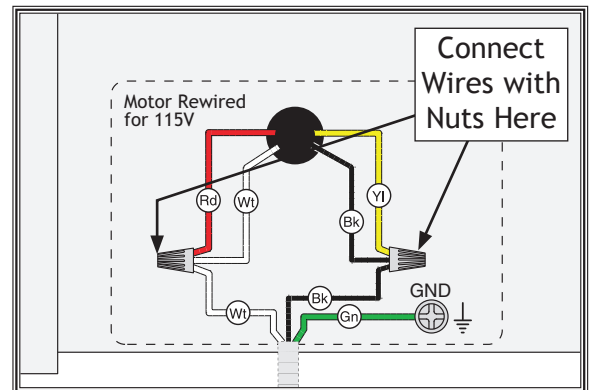
| Items Needed                                    | Qty       |
|---|-----------|
| • Phillips Head Screwdriver #2 .....            | 1         |
| • Electrical Tape .....                         | As Needed |
| • Wire Cutters/Stripper.....                    | 1         |
| • NEMA 5-20 Plug .....                          | 1         |
| • Circuit Breaker 20A (Part # X18511224X) ..... | 1         |

To convert Model W1851 to 115V, do these steps:

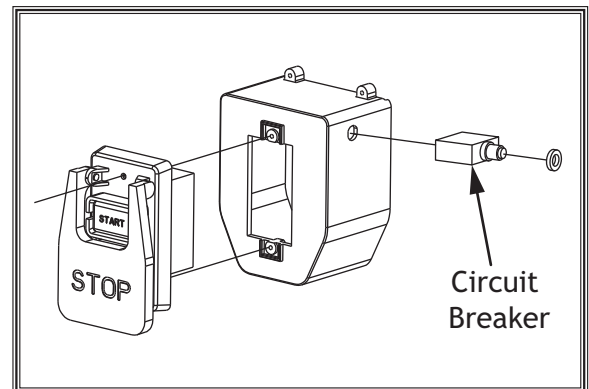
1. DISCONNECT MACHINE FROM POWER!
2. Cut off existing 6-20 plug.
3. Open motor junction box, then loosen three wire nuts indicated in **Figure 7**.
4. Use wire nuts to connect wires as indicated in **Figure 8**. Twist wire nuts onto their respective wires and wrap them with electrical tape so they will not come loose.
5. Close and secure motor junction box.
6. Remove start/stop switch box from the switch mounting plate.
7. Replace pre-installed 10-amp circuit breaker (see **Figure 9**) with a 20-amp circuit breaker (part #X18511224X), then re-install START/STOP switch.
8. Install a 5-20 plug on power cord, according to plug manufacturer's instructions.
  - If plug manufacturer's instructions are not available, NEMA standard 5-20 plug wiring is provided on **Page 85**.



**Figure 7.** Location of wire nuts to be loosened on motor junction box.



**Figure 8.** Motor rewired to 115V.



**Figure 9.** Location of circuit breaker.

ELECTRICAL

# SETUP

## Unpacking


This machine has been carefully packaged for safe transportation. If you notice the machine has been damaged during shipping, please contact your authorized Shop Fox dealer immediately.

## Items Needed for Setup

The following items are needed, but not included, to set up your machine.

| Description                           | Qty       |
|---------------------------------------|-----------|
| • Additional Person.....              | 1         |
| • Safety Glasses for Each Person..... | 1         |
| • Cleaner/Degreaser .....             | As Needed |
| • Disposable Shop Rags .....          | As Needed |
| • Straightedge 4'.....                | 1         |
| • Wrench or Socket 10mm .....         | 1         |
| • Wrench or Socket 13mm .....         | 1         |
| • Wrench or Socket 14mm .....         | 1         |
| • Phillips Head Screwdriver #2 .....  | 1         |
| • Dust Collection System .....        | 1         |
| • Dust Hose 4" .....                  | 1         |
| • Hose Clamps 4" .....                | 2         |

SETUP



**⚠️ WARNING**

This machine presents serious injury hazards to untrained users. Read through this entire manual to become familiar with the controls and operations before starting the machine!



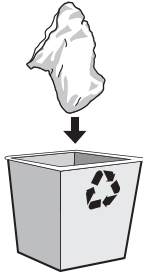
**⚠️ WARNING**

Wear safety glasses during entire setup process!



**⚠️ WARNING**

USE helpers or power lifting equipment to lift this machine. Otherwise, serious personal injury may occur.



**⚠️ WARNING**

**SUFFOCATION HAZARD!**  
Immediately discard all plastic bags and packing materials to eliminate choking/suffocation hazards for children and animals.

# Inventory

The following is a list of items shipped with your machine. Before beginning setup, lay these items out and inventory them.

**Note:** If you cannot find an item on this list, carefully check around/inside the machine and packaging materials. Often, these items get lost in packaging materials while unpacking or they are pre-installed at the factory.

| Box Contents (Figures 10-12)           | Qty |
|--|-----|
| A. Main Table Saw Unit.....            | 1   |
| B. Extension Wings.....                | 2   |
| C. Saw Blade 10" x 40T.....            | 1   |
| D. Motor Door.....                     | 1   |
| E. Wrench 13/27mm.....                 | 1   |
| F. Dado Table Insert.....              | 1   |
| G. Blade Guard Dust Port.....          | 1   |
| H. Blade Guard Assembly.....           | 1   |
| I. Hex Wrench 6-Piece Set 2.5-8mm..... | 1   |
| J. Riving Knife.....                   | 1   |
| K. Miter Gauge and Miter Fence.....    | 1   |
| L. Dust Hose Adapters.....             | 2   |
| M. Push Stick.....                     | 1   |
| N. Dado Blade Flange.....              | 1   |
| O. Handwheels.....                     | 2   |
| P. Handwheel Lock Knobs.....           | 2   |
| Q. Handwheel Handles.....              | 2   |
| R. Dust Hose 94" x 1 1/2".....         | 1   |
| S. Hose Support.....                   | 1   |
| T. Dust Port.....                      | 1   |



Figure 10. Main table saw unit.

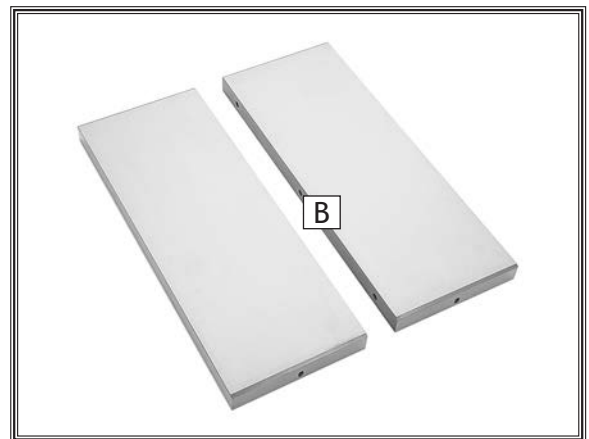


Figure 11. Extension wings.

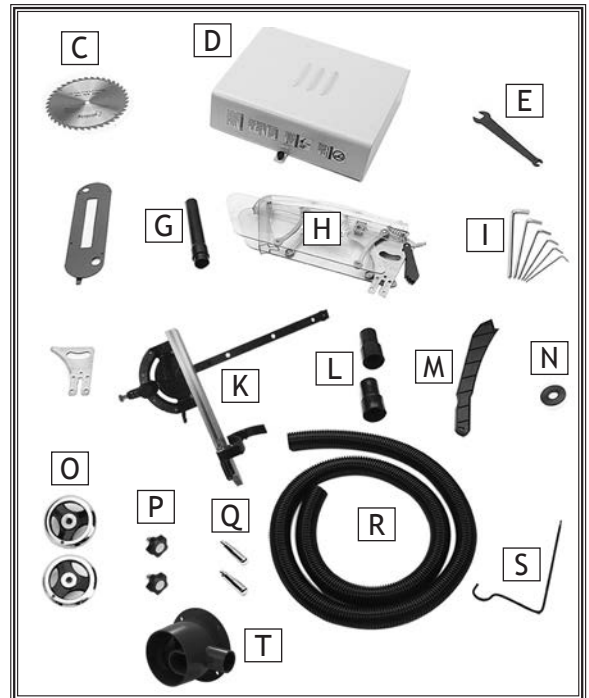


Figure 12. Component inventory.

SETUP

|  |            |
|--|------------|
| <b>Box Contents Cont'd (Figures 13-14)</b> ..... | <b>Qty</b> |
| T. Front Rail Tube 62" .....                     | 1          |
| U. Front Rail Tape Scale .....                   | 1          |
| V. Front Rail 57" .....                          | 1          |
| W. Rear Rail 55" .....                           | 1          |
| X. Fence Assembly .....                          | 1          |
| Y. Extension Table .....                         | 1          |

**Fasteners (Figure 15)** .....

|   |   |
|---|---|
| Z. Cap Screws M10-1.5 x 30 (Wing/Table) .....           | 6 |
| AA. Lock Washers 10mm (Wing/Table) .....                | 6 |
| AB. Flat Washers 10mm (Wing/Table) .....                | 6 |
| AC. Flat Head Screws M8-1.25 x 35 (Front Rail/Table)... | 4 |
| AD. Lock Washers 8mm (Front Rail/Table) .....           | 4 |
| AE. Flat Washers 8mm (Front Rail/Table) .....           | 4 |
| AF. Hex Nuts M8-1.25 (Front Rail/Table) .....           | 4 |
| AG. Cap Screws M6-1 x 16 (Front Rail/Tube) .....        | 5 |
| AH. Lock Washers 6mm (Front Rail/Tube) .....            | 5 |
| AI. Flat Washers 6mm (Front Rail/Tube) .....            | 5 |
| AJ. Cap Screws M10-1.5 x 25 (Rear Rail/Table) .....     | 2 |
| AK. Lock Washers 10mm (Rear Rail/Table) .....           | 2 |
| AL. Flat Washers 10mm (Rear Rail/Table) .....           | 2 |
| AM. Cap Screws M8-1.25 x 35 (Rear Rail/Wing) .....      | 2 |
| AN. Flat Washers 8mm (Rear Rail/Wing) .....             | 4 |
| AO. Lock Washers 8mm (Rear Rail/Wing) .....             | 2 |
| AP. Hex Nuts M8-1.25 (Rear Rail/Wing) .....             | 2 |
| AQ. Flat Head Screws M8-1.25 x 20 (Extension Table)...  | 2 |
| AR. Lock Washers 8mm (Extension Table) .....            | 2 |
| AS. Flat Washers 8mm (Extension Table) .....            | 2 |
| AT. Hex Nuts M8-1.25 (Extension Table) .....            | 2 |
| AU. Cap Screws M8-1.25 x 25 (Extension Table) .....     | 2 |
| AV. Flat Washers 8mm (Extension Table) .....            | 4 |
| AW. Lock Washers 8mm (Extension Table) .....            | 2 |
| AX. Hex Nuts M8-1.25 (Extension Table) .....            | 2 |
| AY. Cap Screws M5-.8 x 14 (Switch) .....                | 2 |
| AZ. Lock Washers 5mm (Switch) .....                     | 2 |
| BA. Flat Washers 5mm (Switch) .....                     | 2 |
| BB. Wing Nut M6-1 (Dust Hose Support) .....             | 1 |
| BC. Flat Washer 6mm (Dust Hose Support) .....           | 1 |
| BD. Hex Nut M6-1 (Dust Hose Support) .....              | 1 |
| BE. Button Head Cap Screws M6-1 x 12(Dust Port) .....   | 4 |
| BF. Flat Washers 6mm (Dust Port) .....                  | 4 |

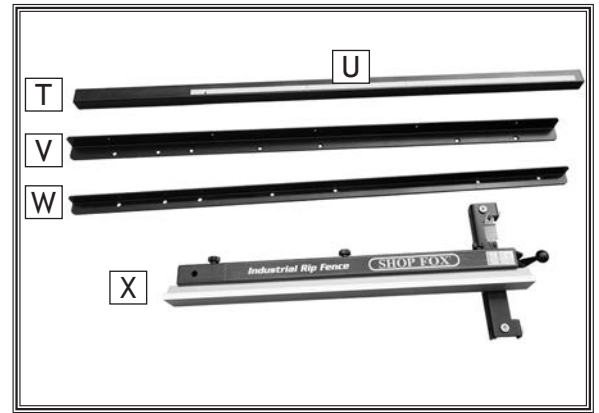


Figure 13. Inventory needed to install fence.

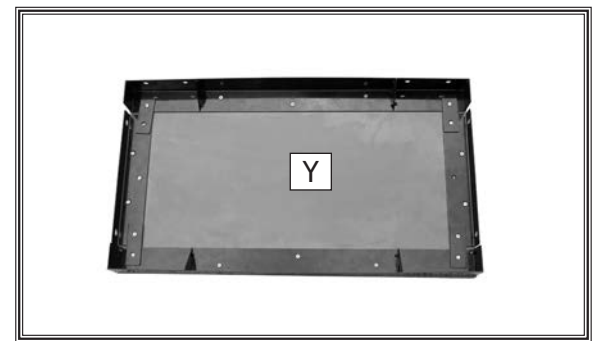


Figure 14. Extension table.

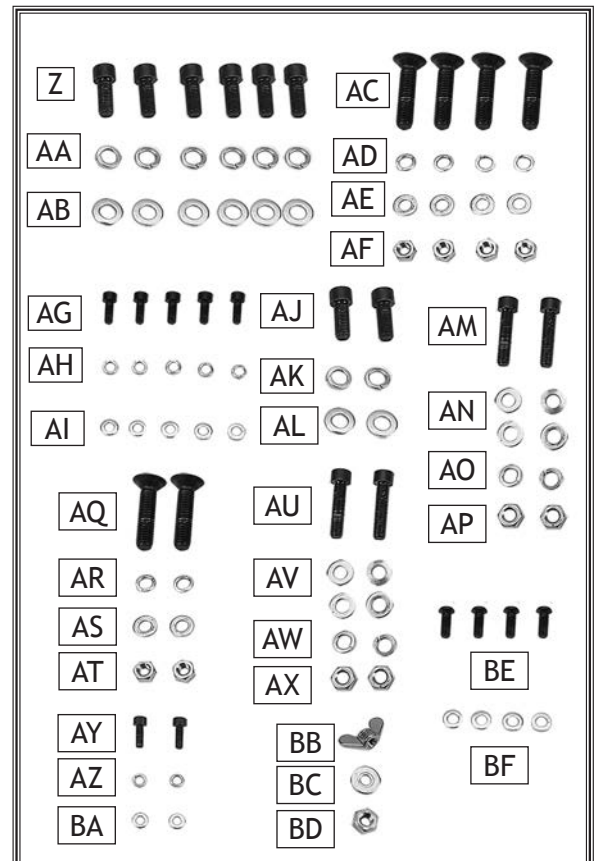
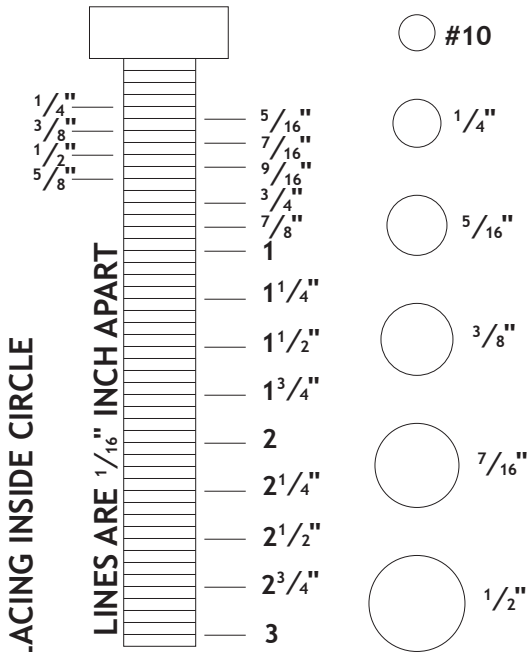


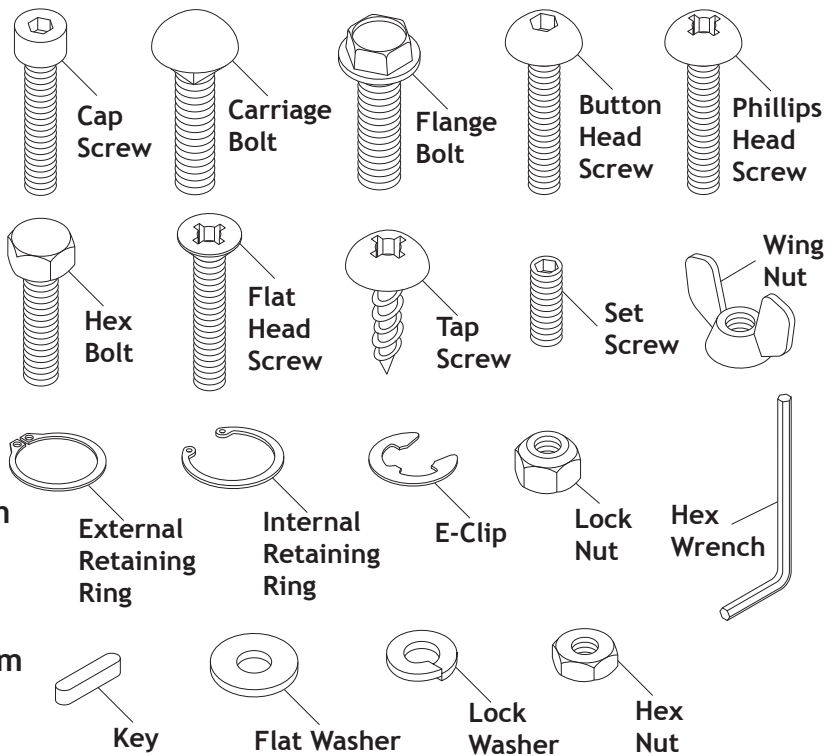
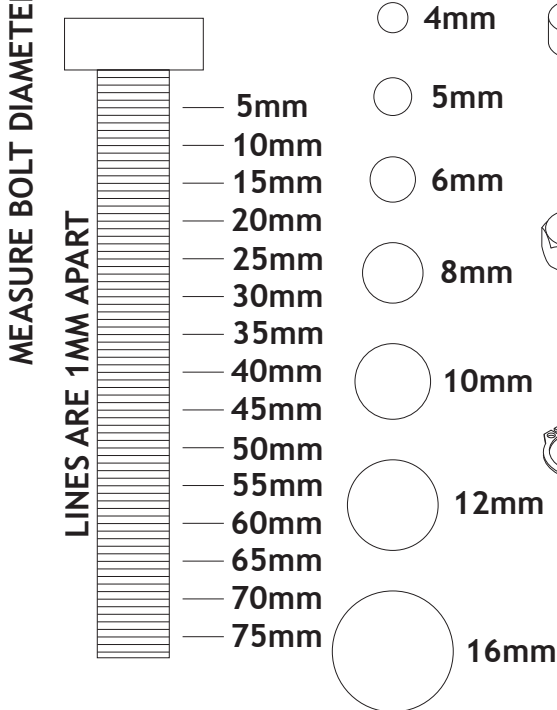
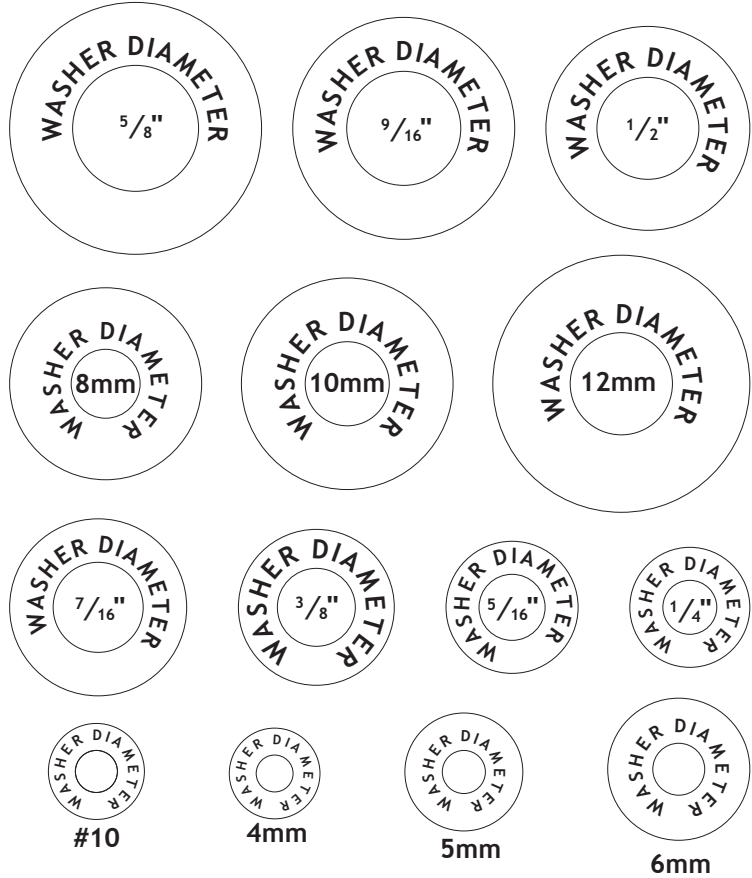
Figure 15. Hardware inventory.

# Hardware Recognition Chart

USE THIS CHART TO IDENTIFY HARDWARE DURING THE INVENTORY/ASSEMBLY PROCESS.



WASHERS ARE MEASURED BY THE INSIDE DIAMETER



SETUP

# Cleaning Machine

To prevent corrosion during shipment and storage of your machine, the factory has coated the bare metal surfaces of your machine with a heavy-duty rust prevention compound.

If you are unprepared or impatient, this compound can be difficult to remove. To ensure that the removal of this coating is as easy as possible, please gather the correct cleaner, lubricant, and tools listed below:

- Cleaner/degreaser designed to remove storage wax and grease
- Safety glasses & disposable gloves
- Solvent brush or paint brush
- Disposable Rags

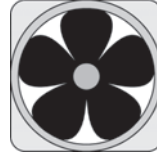
To remove rust preventative coating, do these steps:

1. DISCONNECT MACHINE FROM POWER!
2. Put on safety glasses and disposable gloves.
3. Coat the rust preventative with a liberal amount of cleaner/degreaser, then let it soak for 5-10 minutes.
4. Wipe off surfaces. If your cleaner/degreaser is effective, the coating will wipe off easily.

**Tip:** An easier way to clean off thick coats of rust preventative from flat surfaces is to use a PLASTIC paint scraper to scrape off the majority of the coating before wiping it off with your rag. (Do not use a metal scraper or you may scratch your machine.)

5. Repeat cleaning steps as necessary until all of the compound is removed.
6. To prevent rust on freshly cleaned surfaces, immediately coat with a quality metal protectant.

## WARNING



Gasoline and petroleum products have low flash points and can explode or cause fire if used to clean machinery. Avoid using these products to clean machinery. Many cleaning solvents are toxic if inhaled. Minimize your risk by only using these products in a well ventilated area.

## NOTICE

In a pinch, automotive degreasers, mineral spirits or WD•40 can be used to remove rust preventative coating. Before using these products, though, test them on an inconspicuous area of your paint to make sure they will not damage it.

# Machine Placement

## Weight Load

Refer to the **Machine Specifications** for the weight of your machine. Make sure that the surface upon which the machine is placed will bear the weight of the machine, additional equipment that may be installed on the machine, and the heaviest workpiece that will be used. Additionally, consider the weight of the operator and any dynamic loading that may occur when operating the machine.

## Space Allocation

Consider the largest size of workpiece that will be processed through this machine and provide enough space around the machine for adequate operator material handling or the installation of auxiliary equipment. With permanent installations, leave enough space around the machine to open or remove doors/ covers as required by the maintenance and service described in this manual. **See below for required space allocation.**

## Physical Environment

The physical environment where your machine is operated is important for safe operation and the longevity of its components. For best results, operate this machine in a dry environment that is free from excessive moisture, hazardous chemicals, airborne abrasives, or extreme conditions. Extreme conditions for this type of machinery are generally those where the ambient temperature range exceeds 41°-104°F; the relative humidity range exceeds 20-95% (non-condensing); or the environment is subject to vibration, shocks, or bumps.

## Electrical Installation

Place this machine near an existing power source. Make sure all power cords are protected from traffic, material handling, moisture, chemicals, or other hazards. Make sure to leave access to a means of disconnecting the power source or engaging a lockout/tagout device.

## Lighting

Lighting around the machine must be adequate enough that operations can be performed safely. Shadows, glare, or strobe effects that may distract or impede the operator must be eliminated.

|  |   |
|--|---|
|  | <h3>⚠ CAUTION</h3> <p>Children or untrained people may be seriously injured by this machine. Only install in an access restricted location.</p> |
|--|---|

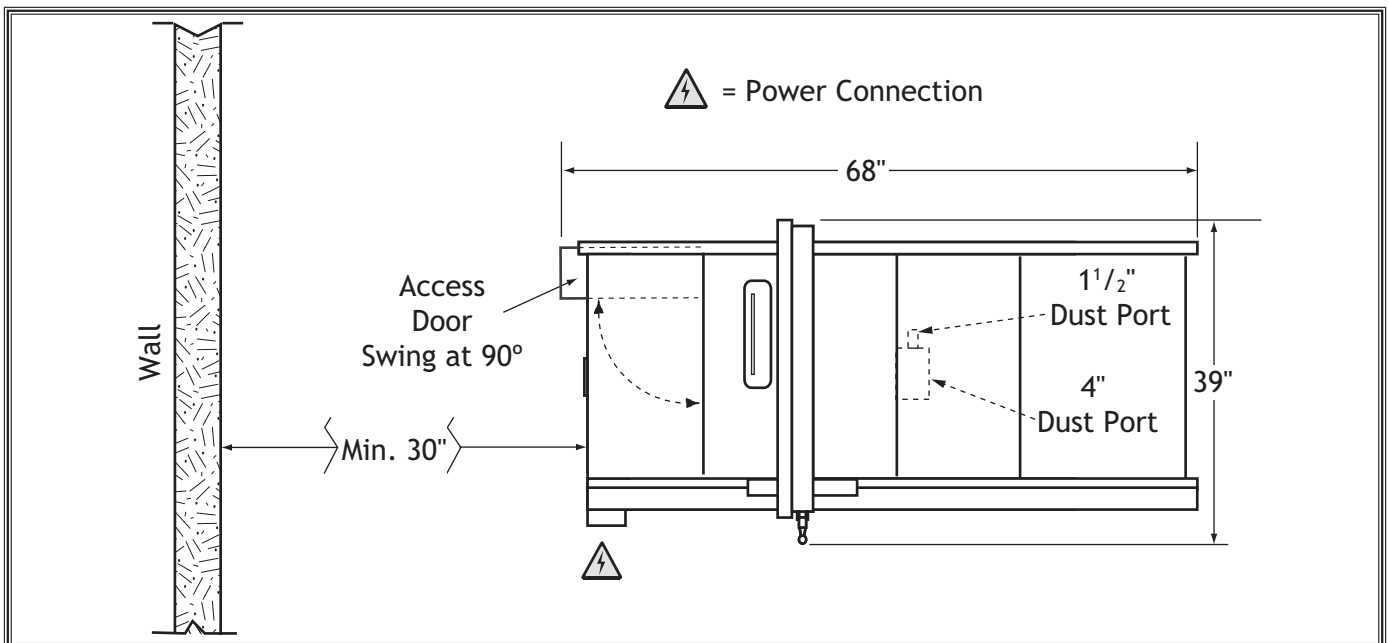


Figure 16. Working clearances.

# Assembly

Before beginning the assembly process, refer to **Items Needed for Setup** and gather everything you need. Ensure all parts have been properly cleaned of any heavy-duty rust-preventative applied at the factory (if applicable). Be sure to complete all steps in the assembly procedure prior to performing the **Test Run**.

To assemble machine, do these steps:

1. Remove foam shipping block (see **Figure 17**). Save block for later machine transport.
2. Remove switch from saw cabinet, and install motor door by inserting door pins into hinge sockets on cabinet (see **Figure 18**).
3. Before closing door, thoroughly clean heavy-duty rust preventative off of gearing inside the saw and coat these with appropriate metal protectant (refer to **Lubrication** on **Page 67** for location of gears).
4. Slide groove on back of each handwheel over handwheel shaft pin, as shown in **Figure 19**.

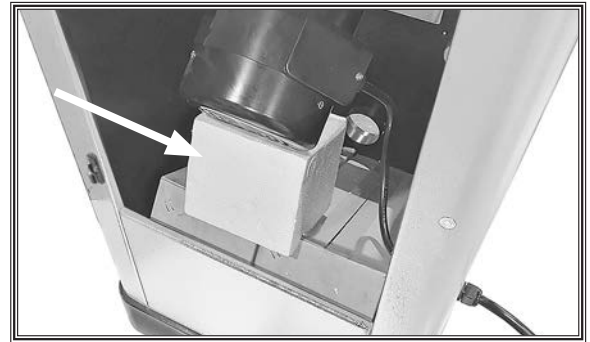


Figure 17. Foam shipping block location.



Figure 18. Motor door installed.

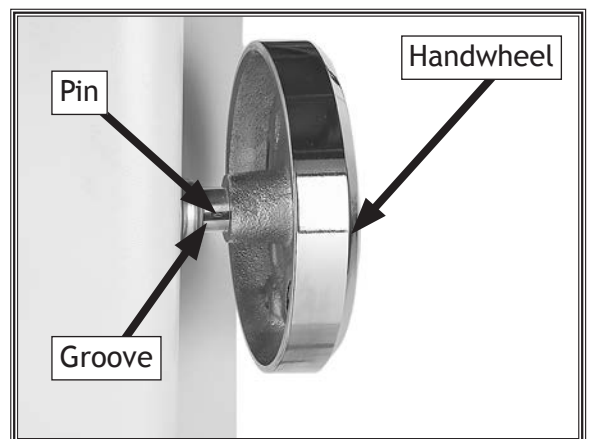
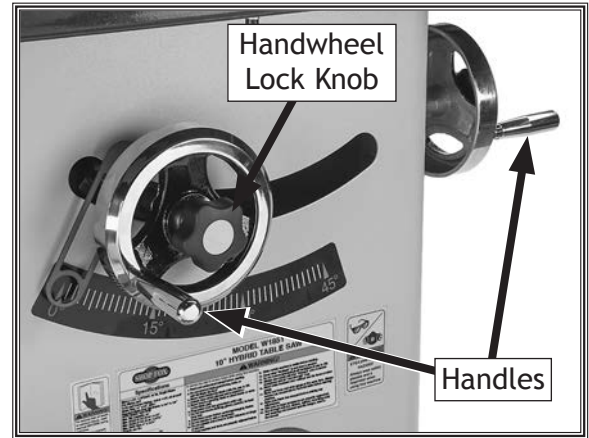


Figure 19. Handwheel installed onto shaft pin.

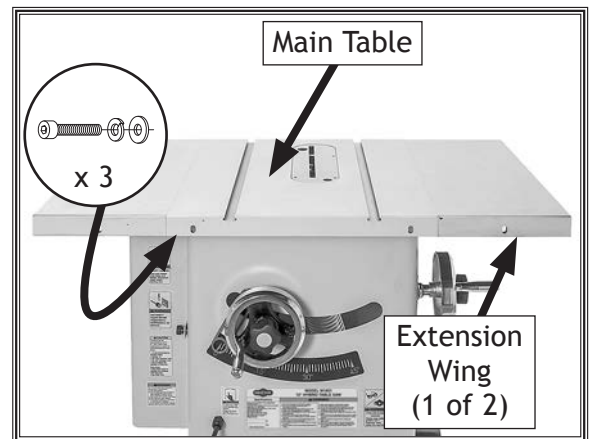
5. Thread a handwheel lock knob into center of each handwheel and tighten, then thread a handle onto each handwheel and tighten (see **Figure 20**).
6. Inspect extension wings and main table mating surfaces for burrs or foreign materials that may inhibit assembly.

For a correct fit, mating edges of table and wings must be clean, smooth, and flat. If necessary, use a wire brush or file to remove any flashing, dings, or high spots.



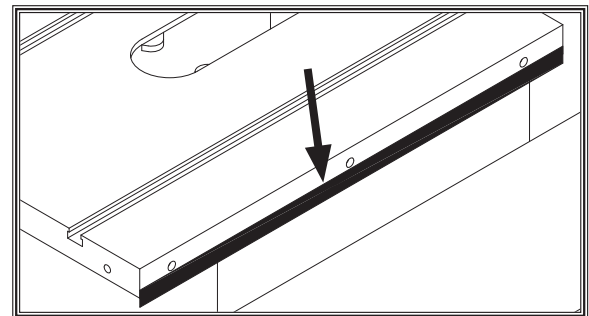
**Figure 20.** Handwheel installed.

7. While a helper holds wings in place, attach each extension wing to main table with (3) M10-1.5 x 30 cap screws, 10mm lock washers, and 10mm flat washers (see **Figure 21**).



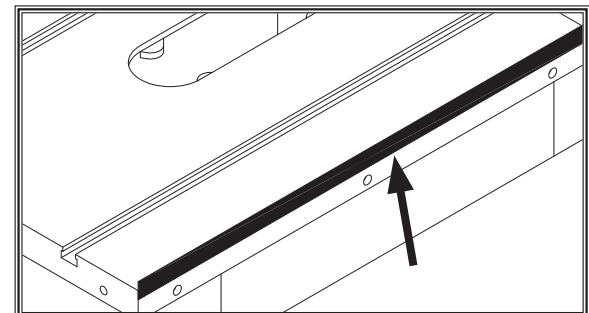
**Figure 21.** Extension wings installed.

8. Place straightedge across extension wings and main table to make sure that combined table surface is flat.
  - If combined table surface is flat, skip to next step.
  - If outside end of extension wing tilts down, place a strip of masking tape along bottom edge of main table to shim end of extension wing up (see **Figure 22**).



**Figure 22.** Masking tape location for tilting extension wing up.

- If outside end of extension wing tilts up, place strip of masking tape along top edge of main table to shim end of extension wing down (see **Figure 23**).



**Figure 23.** Masking tape location for adjusting the extension wing down.

**Note:** After re-installing wings, remove all excess masking tape with a razor blade.

- Attach front rail to table and extension wings with (4) M8-1.25 x 35 flat head screws, 8mm flat washers, 8mm lock washers, and M8-1.25 hex nuts, as shown in **Figure 24**. Make sure top of rail is parallel with table top before fully tightening fasteners.

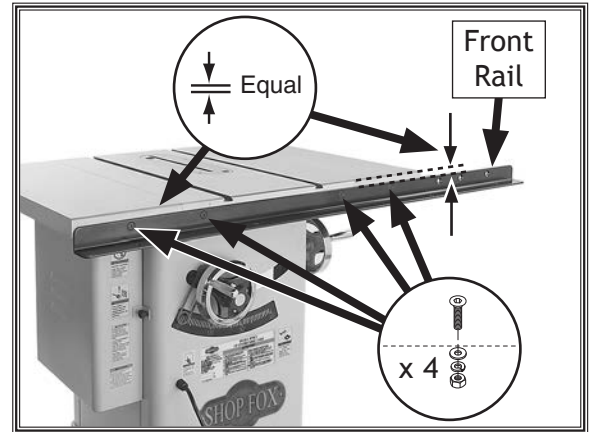


Figure 24. Front rail installed.

- Install front rail tube onto front rail with (5) M6-1 x 16 cap screws, 6mm flat washers, and 6mm lock washers, as shown in **Figure 25**. Finger-tighten fasteners.
- While standing at front of table, pull rail tube toward you as far as possible, then final tighten fasteners loosely installed in **Step 10**. This will help make sure there is enough room for fence to slide.

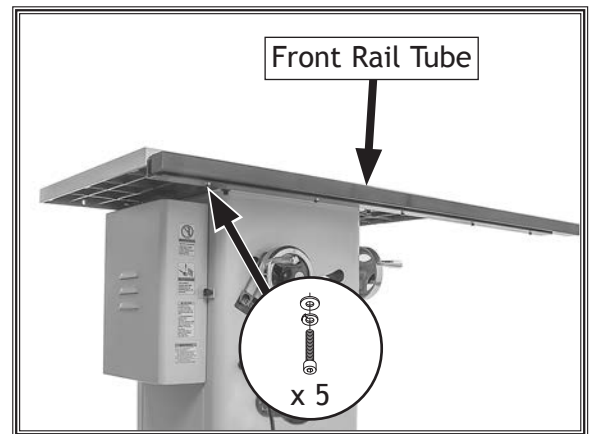


Figure 25. Front rail tube attached to front rail.

- Attach rear rail to holes on main table using (2) M10-1.5 x 30 cap screws, 10mm lock washers, and 10mm flat washers, as shown in **Figure 26**. Check to make sure rear rail is parallel to table and below miter slots before completely tightening cap screws.
- Secure rear rail to extension wings with (2) M8-1.25 x 35 cap screws, (4) 8mm flat washers, (2) 8mm lock washers, and (2) M8-1.25 hex nuts (see **Figure 26**).

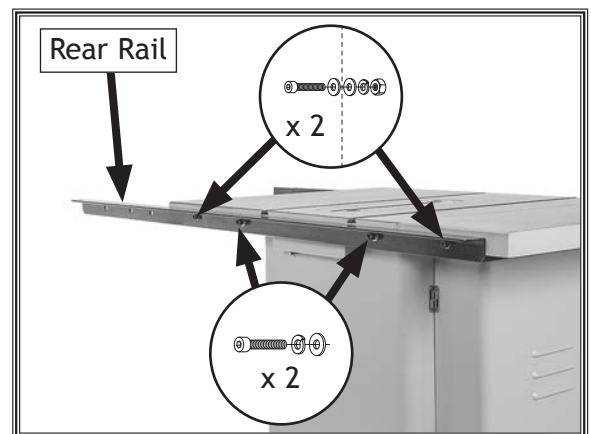
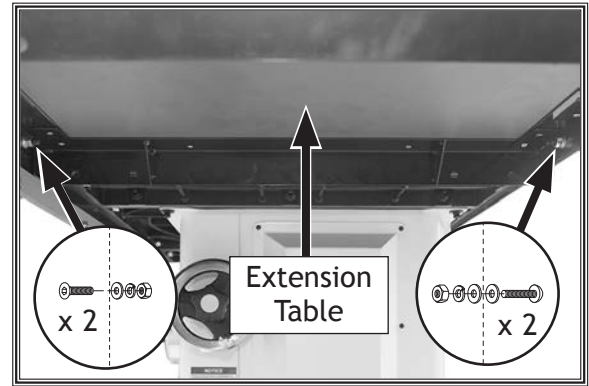


Figure 26. Rear rail installed.

14. Attach extension table to front rail with (2) M8-1.25 x 20 flat head cap screws, 8mm flat washers, 8mm lock washers, and M8-1.25 hex nuts (see **Figure 27**).
15. Attach extension table to rear rail with (2) M8-1.25 x 25 cap screws, (4) 8mm flat washers, (2) 8mm lock washers, and (2) M8-1.25 hex nuts (see **Figure 27**).



**Figure 27.** Extension table installed.

16. Using a long straightedge, adjust extension table so it is flat (both flush and parallel) with the main table and extension wings (see **Figure 28**), then tighten fasteners.
17. Install saw blade as outlined in **Blade Installation** on **Page 35**.

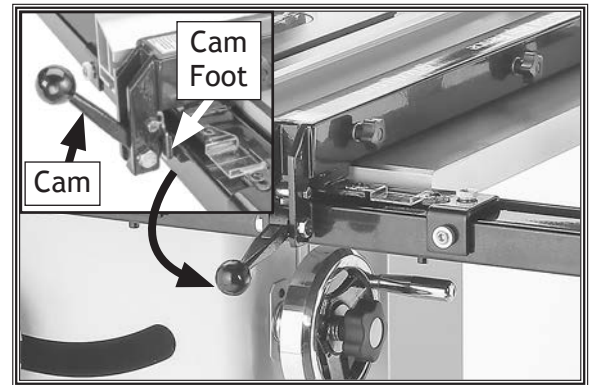


**Figure 28.** Adjusting extension table flush with wing and table.

18. Place fence on rails (on right hand side of blade, as shown in **Figure 29**).

*Note: Make sure cam foot contacts cam on fence lock handle before you place fence on rail; otherwise, fence will not lock onto rail tube.*

19. Adjust foot at rear of fence so that gap between fence and table top is even from front to back.



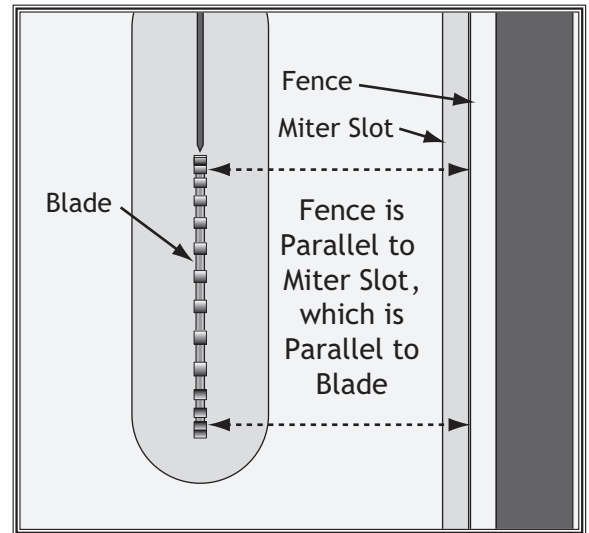
**Figure 29.** Fence installed on rails.

SETUP

20. Slide fence up against right hand edge of miter slot, and lock it in place. Examine how fence lines up with miter slot (see **Figure 30**).

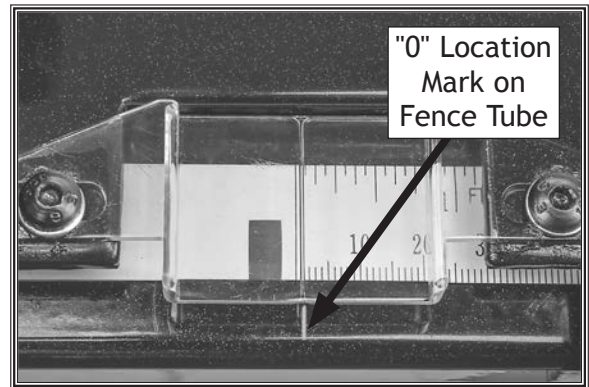
**Note:** It is permissible for back of fence to pivot outward not more than  $\frac{1}{64}$ " from being parallel with miter slot. This creates a slightly larger opening between fence and blade, at rear of blade, to reduce risk of workpiece binding or burning as it is fed through cut. Many woodworkers intentionally set up their fence in this manner. Keep this in mind before adjusting your fence. For more details, see **Figure 122 on Page 76**.

- If fence is still parallel with miter slot, proceed to **Step 21**.
- If fence is *not* parallel with miter slot, then you **MUST** adjust fence, as described in **Fence Adjustments on Page 74**, so that it is parallel.
- If miter slot is *not* parallel with blade, you must follow procedures described in **Miter Slot to Blade Parallelism on Page 70**.



**Figure 30.** Checking fence parallelism with blade.

21. Carefully slide fence so it barely touches saw blade and lock it in place.
22. Lightly mark "0" location on fence tube (under indicator line on pointer window) with a pencil, as shown in **Figure 31**, then remove fence.
23. Peel front rail scale tape, carefully align "0" mark on scale with pencil mark you made on fence tube, and make sure tape is parallel to fence tube along its length.



**Figure 31.** "0" location marked on fence tube.

24. Re-install fence, move it over to just touch blade, and verify that indicator line is directly over "0" mark.
  - If you need to correct position of indicator line, loosen button head screws on pointer window, adjust pointer window so line is over "0" mark on tape (see Figure 32), then secure screws.
25. Install blade guard as outlined on Page 37.

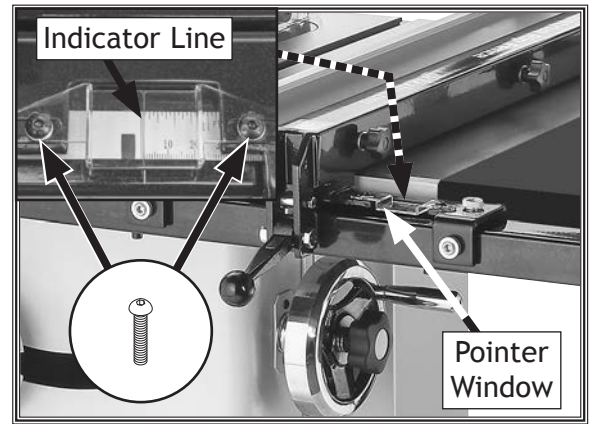


Figure 32. Aligning rail tape with scale pointer.

26. Attach START/STOP switch to bottom left-hand side of front rail using (2) M5-.8 x 14 cap screws, 5mm lock washers, and 5mm flat washers, as shown in Figure 33.

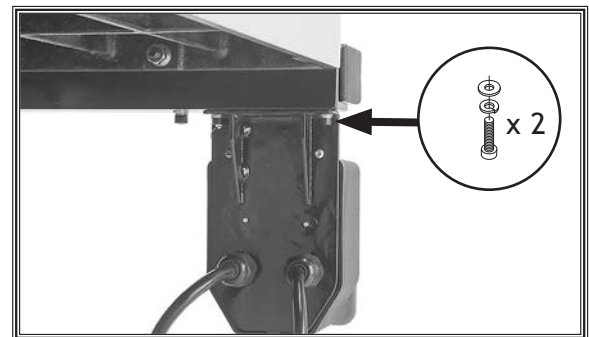


Figure 33. Switch installed.

27. Attach dust hose support to rear rail with (1) M6-1 hex nut, 6mm flat washer, and M6-1 wing nut, as shown in Figure 34, so open end of hook faces outward.

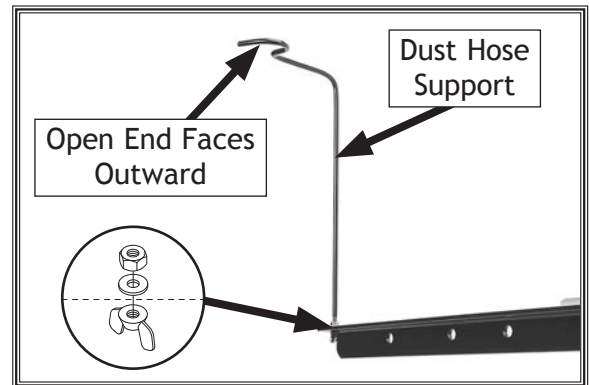


Figure 34. Dust hose support installed.

28. Attach dust port to cabinet using (4) M6-1 x 12 button head cap screws and (4) 6mm flat washers, as shown in Figure 35.

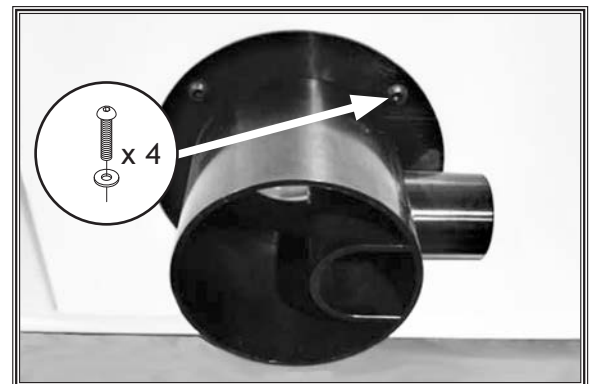


Figure 35. Dust port installed.

SETUP

# Dust Collection

Recommended CFM at Dust Port: ..... 500 CFM+

Do not confuse this CFM recommendation with the rating of the dust collector. To determine the CFM at the dust port, you must consider these variables: (1) CFM rating of the dust collector, (2) hose type and length between the dust collector and the machine, (3) number of branches or wyes, and (4) amount of other open lines throughout the system. Explaining how to calculate these variables is beyond the scope of this manual. Consult an expert or purchase a good dust collection “how-to” book.

## CAUTION

This machine creates substantial amounts of dust during operation. Breathing airborne dust on a regular basis can result in permanent respiratory illness. Reduce your risk by wearing a respirator and capturing the dust with a dust collection system.

SETUP

| Components Needed:                          | Qty |
|---|-----|
| Dust Hose Adapters 1 1/2".....              | 2   |
| Dust Hose 94" x 1 1/2" .....                | 1   |
| Dust Hose 4" (not included).....            | 1   |
| Hose Clamps 4" (not included).....          | 2   |
| Dust Collection System (not included) ..... | 1   |

To connect dust collection hoses, do these steps:

1. Attach a dust hose adapter to each end of dust hose (see Figure 36).
2. Slide one adapter onto 1 1/2" dust port (see Figure 37), until it fits snugly.
3. Attach dust hose to dust hose support, then insert dust port into rear of blade guard assembly (see Figure 37).
4. Fit 4" dust hose over dust port, as shown in Figure 38, and tightly secure it in place with a hose clamp.
5. Tug hose to make sure it does not come off.

**Note:** A tight fit is necessary for proper performance.

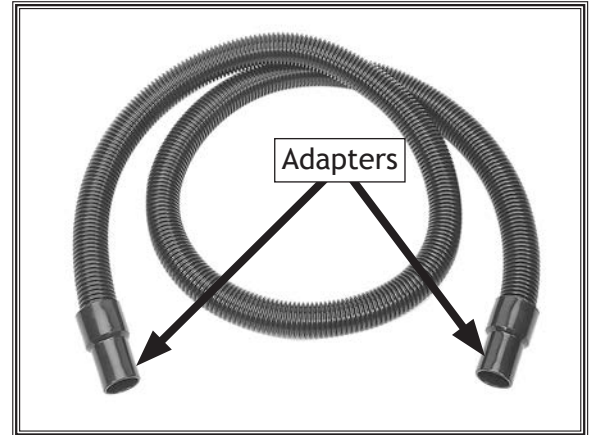


Figure 36. Adapters attached to dust hose.

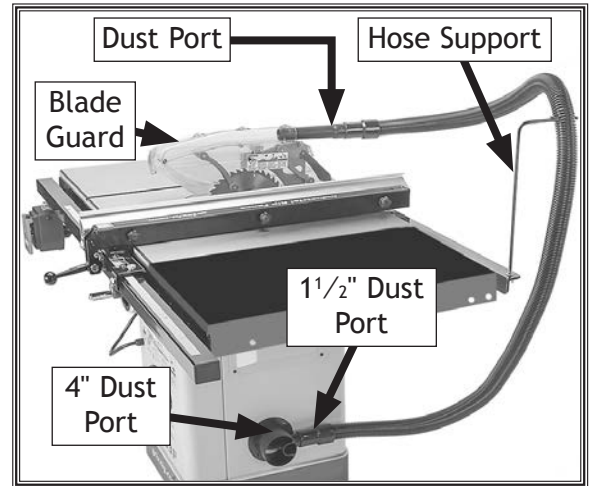


Figure 37. Dust hose attached to saw, hose support, and blade guard dust port.

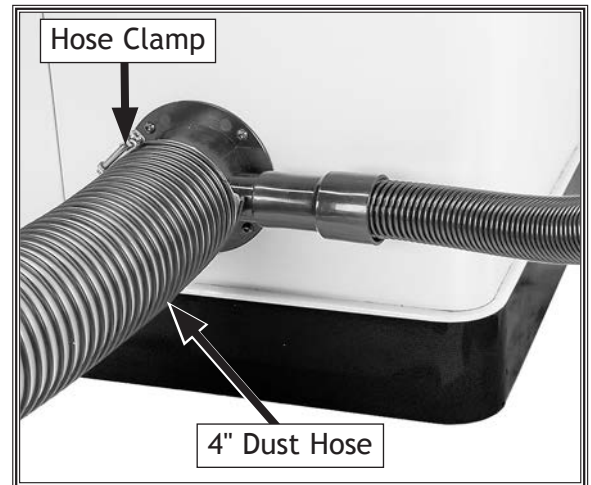


Figure 38. Dust hoses attached to port.

## Test Run

Once assembly is complete, test run the machine to ensure it is properly connected to power and safety components are functioning properly.

If you find an unusual problem during the test run, immediately stop the machine, disconnect it from power, and fix the problem **BEFORE** operating the machine again. The **Troubleshooting** table in the **SERVICE** section of this manual can help.

The test run consists of verifying the following: 1) The motor powers up and runs correctly, and 2) the safety disabling mechanism on the switch works correctly.

To test run the machine, do these steps:

1. Clear all setup tools away from machine.
2. Connect machine to power supply.
3. Turn machine **ON**, verify motor operation, and then turn machine **OFF**.

The motor should run smoothly and without unusual noises.

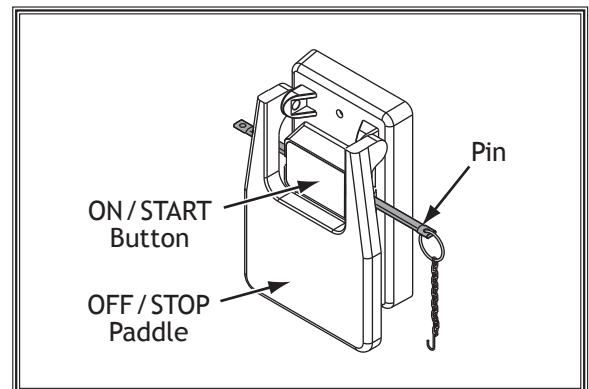
4. Insert switch disabling pin through green START button, as shown in **Figure 39**.
5. Press green ON/START button to test disabling feature on switch.
  - If machine *does not* start, switch disabling feature is working as designed.
  - If machine *does* start, immediately stop machine. The switch disabling feature is not working correctly. This safety feature must work properly before proceeding with regular operations. Call Tech Support for help.

**⚠ WARNING**

Serious injury or death can result from using this machine **BEFORE** understanding its controls and related safety information. **DO NOT** operate, or allow others to operate, machine until the information is understood.

**⚠ WARNING**

**DO NOT** start machine until all preceding setup instructions have been performed. Operating an improperly set up machine may result in malfunction or unexpected results that can lead to serious injury, death, or machine/property damage.



**Figure 39.** Example of switch disabling pin inserted into START button.

# OPERATIONS

## General

This machine will perform many types of operations that are beyond the scope of this manual. Many of these operations can be dangerous or deadly if performed incorrectly.

The instructions in this section are written with the understanding that the operator has the necessary knowledge and skills to operate this machine. If at any time you are experiencing difficulties performing any operation, stop using the machine!

The overview below provides the novice machine operator with a basic understanding of how the machine is used during operation, so the machine controls/components discussed later in this manual are easier to understand. Due to its generic nature, this overview is **NOT** intended to be an instructional guide.

To complete a typical operation, the operator does the following:

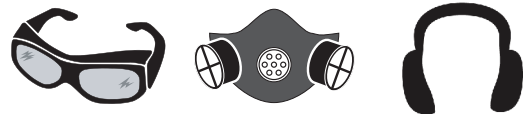
1. Examines workpiece to make sure it is suitable for cutting.
2. Adjusts blade tilt, if necessary, to correct angle for desired cut.
3. Adjusts blade height no more than 1/4" higher than thickness of workpiece.
4. Adjusts fence to desired width of cut, then locks it in place.
5. Checks outfeed side of machine for proper support and to make sure workpiece can safely pass all the way through blade without interference.
6. Puts on safety glasses, respirator, and hearing protection, and locates push sticks/blocks if needed.
7. Starts saw.
8. Feeds workpiece all the way through blade while maintaining firm pressure on workpiece against table and fence, and keeping hands and fingers out of blade path and away from blade.
9. Stops machine immediately after cut is complete.

### **WARNING**



To reduce your risk of serious injury or damage to the machine, read this entire manual **BEFORE** using machine.

### **WARNING**



Eye injuries, respiratory problems, or hearing loss can occur while operating this machine. Wear personal protective equipment to reduce your risk from these hazards.

### **NOTICE**

If you are an inexperienced operator, we strongly recommend that you read books or trade articles, or seek training from an experienced operator of this type of machinery before performing unfamiliar operations. Above all, safety must come first!

# Workpiece Inspection

Some workpieces are not safe to cut on this machine or may need to be modified before they can be safely cut.

**Before beginning the cutting operation, inspect all workpieces for the following:**

- **Material Type.** This machine is intended for cutting natural and man-made wood products, laminate covered wood products, and some plastics. Cutting drywall or cementitious backer board creates extremely fine dust and may reduce the life of the motor bearings. This machine is NOT designed to cut metal, glass, stone, tile, etc.; cutting these materials with a table saw may lead to injury.
- **Foreign Objects.** Nails, staples, dirt, rocks and other foreign objects are often embedded in wood. While cutting, these objects can become dislodged and hit the operator, cause kickback, or break the blade, which might then fly apart. Always visually inspect your workpiece for these items. If they can't be removed, DO NOT cut the workpiece.
- **Large/Loose Knots.** Loose knots can become dislodged during the cutting operation. Large knots can cause kickback and machine damage. Choose workpieces that do not have large/loose knots or plan ahead to avoid cutting through them.
- **Wet or "Green" Stock.** Cutting wood with a moisture content over 20% causes unnecessary wear on the blades, increases the risk of kickback, and yields poor results.
- **Excessive Warping.** Workpieces with excessive cupping, bowing, or twisting are dangerous to cut because they are unstable and may move unpredictably when being cut.
- **Minor Warping.** Slightly cupped workpieces can be safely supported with the cupped side facing the table or fence; however, workpieces supported on the bowed side will rock during the cut, which could cause kickback or severe injury.

# Non-Through & Through Cuts

## Non-Through Cuts

A non-through cut is a sawing operation where the blade does not protrude above the top face of the wood stock, as shown in **Figure 40**.

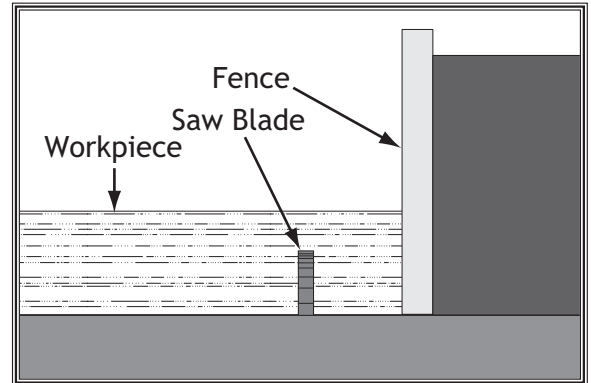
Examples of non-through cuts include dadoes and rabbets. Non-through cuts have a higher risk of injury from kickback because the blade guard must be removed. However, the riving knife **MUST** be installed because it still provides some protection.

**IMPORTANT:** When making non-through cuts with a dado blade, do not attempt to cut the full depth in one pass. Instead, take multiple light passes to reduce the load on the blade.

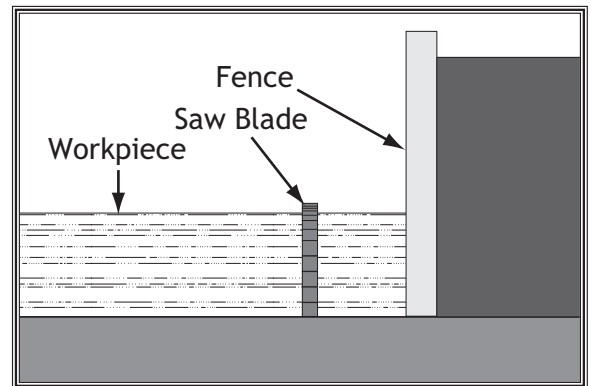
A dado blade smaller than 10" will require removal of the riving knife, because the riving knife will be higher than the blade.

## Through Cuts

A through cut is a sawing operation in which the workpiece is completely sawn through, as shown in **Figure 41**. Examples of through cuts are rip cuts, cross cuts, miter cuts, and beveled cuts. The blade guard assembly **MUST** be used when performing through cuts.



**Figure 40.** Example of a non-through cut.



**Figure 41.** Example of a through cut (blade guard not shown for illustrative purposes).

## **NOTICE**

If you have never used this type of machine or equipment before, seek training from an experienced machine operator or read "how to" books before beginning any projects. Regardless of the content in this section, Shop Fox will not be held liable for accidents caused by lack of training.

# Blade Size Requirements

When choosing a main blade, make sure the blade size meets the requirements listed below. The thickness of the blade body and teeth can be measured with calipers or any precision measuring device.

### Blade Size Requirements:

- Body Thickness: 0.063"-0.094" (1.8-2.4mm)
- Kerf (Tooth) Thickness: 0.102"-0.126" (2.6-3.2mm)
- Riving Knife Thickness: 0.1" (2.5mm)
- Blade Size Required for Riving Knife: 10"

**⚠ WARNING**

Using a blade that does not meet the specified blade size requirements presents a hazardous condition that could cause kickback, operator injuries, or property damage. ALWAYS use a blade that meets the given blade size requirements.

## Blade Selection

This section on blade selection is by no means comprehensive. Always follow the saw blade manufacturer's recommendations to ensure safe and efficient operation of your table saw.

### Ripping Blade Features (Figure 42):

- Best for cutting with the grain
- 20-40 teeth
- Flat-top ground tooth profile
- Large gullets for large chip removal

### Crosscut Blade Features (Figure 43):

- Best for cutting across the grain
- 60-80 teeth
- Alternate top bevel tooth profile
- Small hook angle and a shallow gullet

### Combination Blade Features (Figure 44):

- Designed to cut both with and across grain
- 40-50 teeth
- Alternate top bevel and flat, or alternate top bevel and raker tooth profile
- Teeth are arranged in groups
- Gullets are small and shallow (similar to a cross-cut blade), then large and deep (similar to a ripping blade)

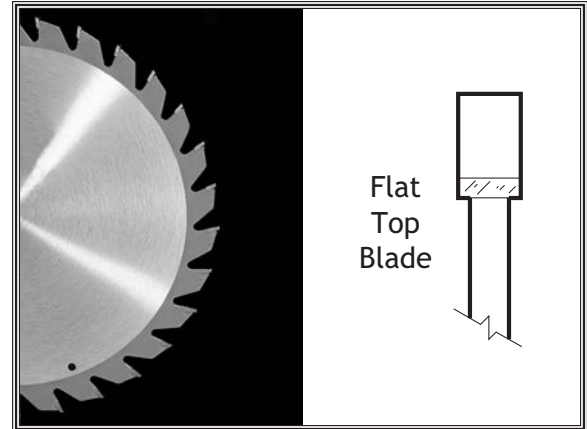


Figure 42. Example of a ripping blade.

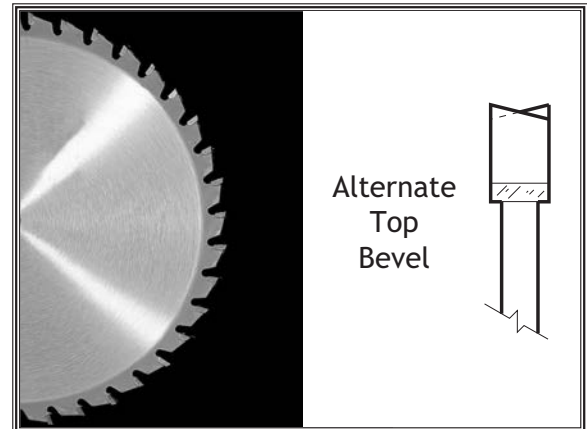


Figure 43. Example of a crosscut blade.

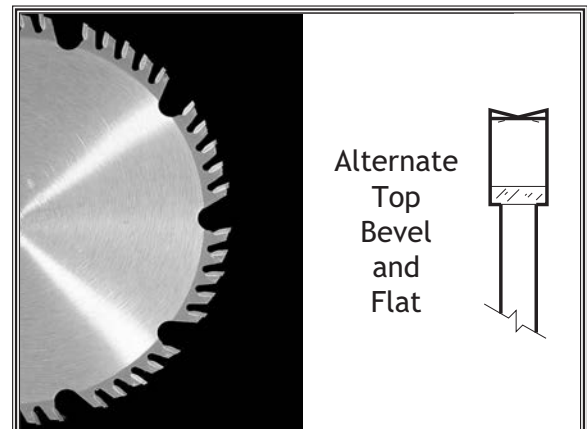


Figure 44. Example of a combination blade.

**Laminate Blade Features (Figure 45):**

- Best for cutting plywood or veneer
- 40-80 teeth
- Triple chip tooth profile
- Very shallow gullet

**Thin Kerf Blade:** A blade with thinner kerf than a standard blade. Since the spreader/riving knife included with this table saw is sized for standard blades, thin kerf blades *cannot* be used on this saw unless they meet the **Blade Requirements** specified in this manual; otherwise, they will increase the risk of kickback.

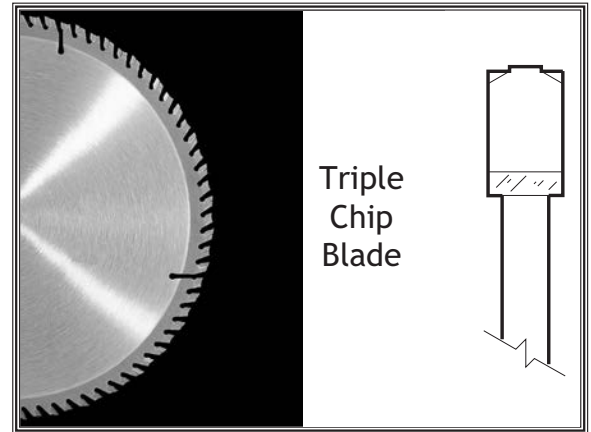


Figure 45. Example of a laminate blade.

**Dado Blades**

**Stacked Dado Blade (see Figure 46):** Multiple blades are stacked together to control the cutting width. Stacked dado blades are more expensive than wobble blades, but typically produce higher quality results.

**Wobble Dado Blade:** A single blade mounted at a slight angle on an arbor hub. The blade angle is adjustable on the hub, and the width of the dado cut is controlled by the angle setting of the blade.

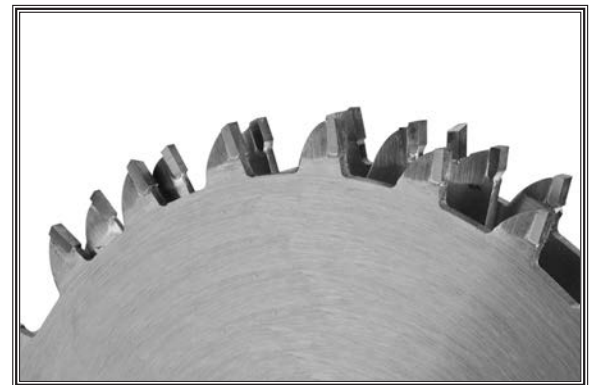


Figure 46. Stacked dado blade.

# Blade Installation

Review this section, even if your saw blade came pre-installed.

| Items Needed              | Qty    |
|---------------------------|--------|
| Leather Work Gloves ..... | 1 Pair |
| Arbor Wrench .....        | 1      |

To install blade, do these steps:

1. DISCONNECT MACHINE FROM POWER!
2. Raise arbor all the way up, then remove blade guard and spreader/riving knife, (see Pages 37 & 40) and table insert.
3. Push arbor lock (see Figure 47) in and turn blade until it locks in place.
4. While pressing arbor lock, use included arbor wrench to loosen and remove arbor nut, flange, and blade (see Figure 48). Arbor nut has right-hand threads; rotate counterclockwise to loosen.

## CAUTION

To reduce risk of injury, always disconnect power to saw before changing blades. Since the blade is sharp, use extra care and wear gloves when installing it.

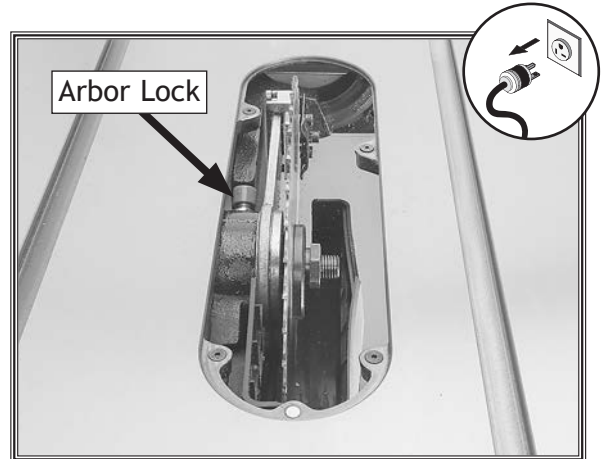


Figure 47. Location of arbor lock.

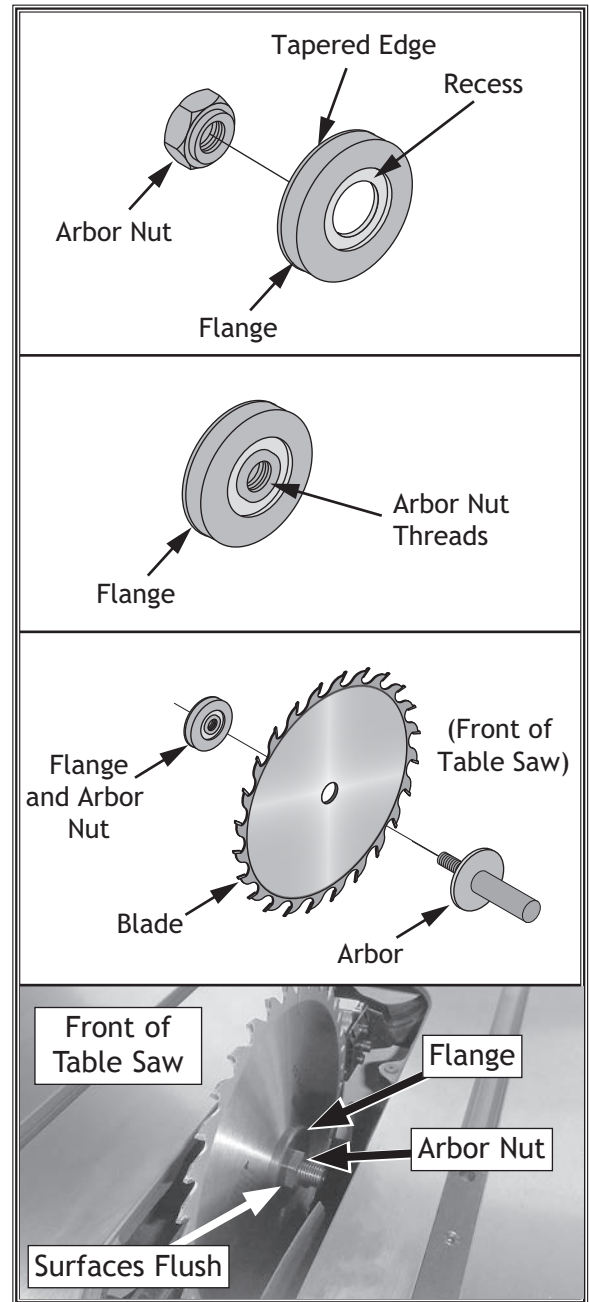


Figure 48. Example of removing table saw blade.

5. Install new blade, flange, and arbor nut on arbor, as shown in **Figure 49**, with upper teeth facing front of saw. Ensure the tapered edge of the flange faces the arbor nut and the recess faces away from the arbor nut. The arbor nut should be flush with the outer surface of the flange.

**IMPORTANT:** Make sure you install the components in the correct orientation or the saw blade will not be properly secured!

6. Secure blade with arbor lock, then tighten flange and arbor nut against blade with arbor wrench. DO NOT overtighten.
7. Re-install table insert (see **Page 78**) and blade guard (see **Page 37**) or riving knife (see **Page 40**).



**Figure 49.** Blade order of installation and teeth facing correct direction.

# Blade Guard Assembly

The term "blade guard" refers to the assembly that consists of the clear polycarbonate shield and dust enclosure, the spreader, and the anti-kickback pawls on each side of the spreader (see **Figure 50**). Each of these components have important safety functions during the operation of the saw.

## Guard

The clear polycarbonate guard allows the operator to see the blade cut the workpiece during operation. This guard is designed to lift as the workpiece is pushed into the blade and remain in contact with the workpiece throughout the entire cut.

The guard reduces injury risk by providing a barrier around the blade that prevents accidental contact and contains flying wood chips.

To ensure that the guard does its job effectively, the guard must always be in the downward position against the table during idle operation, and the hinge mechanism must be maintained in good working condition so the guard can freely pivot up and down to accommodate the height of the workpiece and return to the table surface.

## Spreader

The spreader is a metal plate that prevents the newly cut kerf of the workpiece from pinching the backside of the blade, causing kickback.

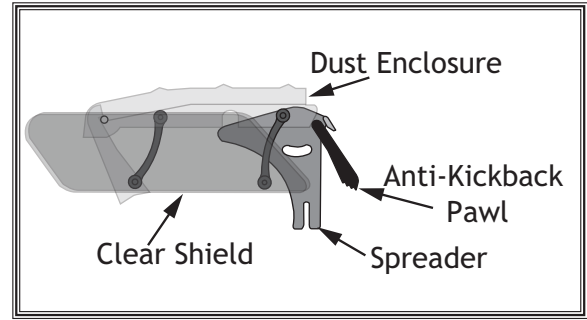
The spreader also acts as a barrier behind the blade to shield hands from being pulled into the blade if a kickback occurs.

## Installing Blade Guard & Spreader

| Tools Needed         | Qty |
|----------------------|-----|
| Hex Wrench 3mm ..... | 1   |
| Straightedge .....   | 1   |

To install blade guard and spreader, do these steps:

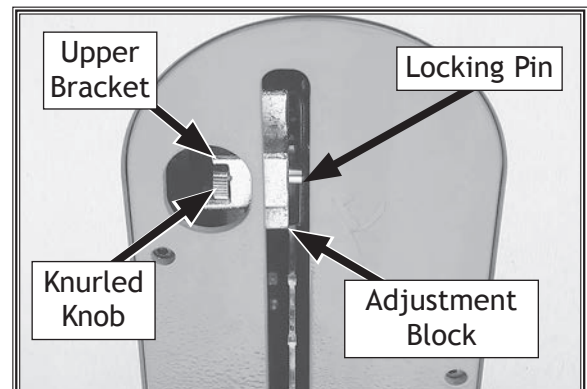
1. DISCONNECT MACHINE FROM POWER!
2. Install table insert, then raise blade all the way up.
3. Slide knurled knob out (see **Figure 51**) and rotate it so it engages upper bracket.



**Figure 50.** Blade guard assembly components.

**⚠ CAUTION**

In order to work properly, the spreader cannot be bent or misaligned with the blade. If the spreader gets accidentally bent, take the time to straighten it or just replace it. Using a bent or misaligned spreader will increase the risk of kickback! Refer to Page 72 to check or adjust alignment if necessary.



**Figure 51.** Knurled knob used to secure spreader.

4. Slide blade guard spreader all the way down into adjustment block, then rotate knurled knob so it disengages bracket and locking pin engages hole in center of spreader.
5. Give spreader an upward tug to verify that it is locked.

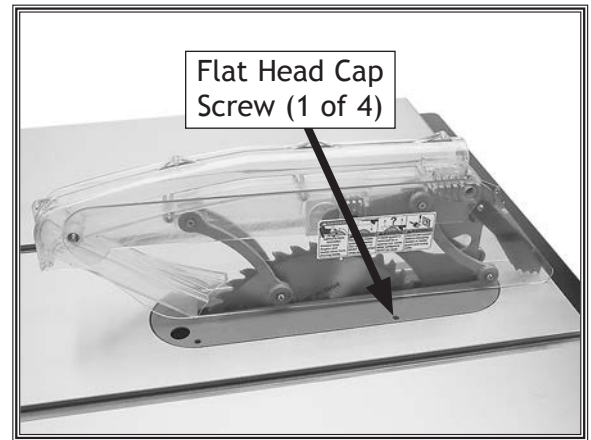
The blade guard, when properly installed, should be set up similarly to **Figure 52**. It should pivot freely up and down and return to the table in the resting position. It should also swing up high enough to accommodate the workpiece.

6. Adjust flat head cap screws (see **Figure 52**) to make sure table insert is flush with table (use a straightedge as a guide).
7. While lifting up on one side of blade guard and right spreader pawl, place straightedge against blade and spreader, making sure straightedge *does not* touch a blade tooth.

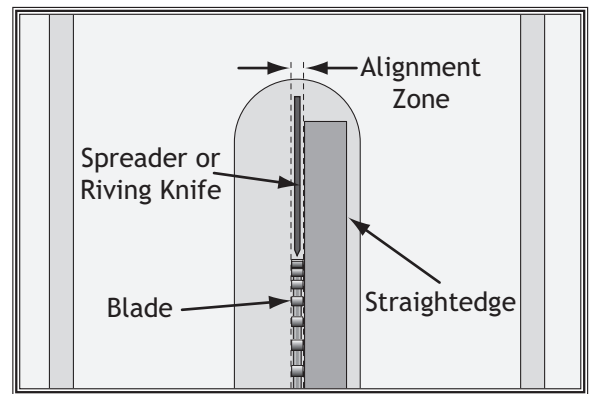
When properly aligned, spreader/riving knife will be in "Alignment Zone," shown in **Figure 53**, and will be parallel with blade.

– If spreader/riving knife is not inside alignment zone and not parallel with blade, then it needs to be adjusted. Proceed to "Adjusting Alignment" on **Page 73**.

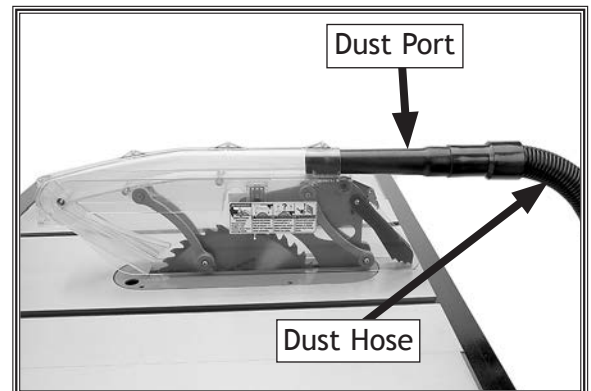
8. Install blade guard dust port and dust collection hose, as shown in **Figure 54**, and attach hose to dust collection port on table saw body (refer to **Page 28**).



**Figure 52.** Blade guard installed.



**Figure 53.** Spreader/riving knife alignment zone.



**Figure 54.** Dust port and dust collection hose installed on blade guard.

## Anti-Kickback Pawls

The anti-kickback pawls allow the workpiece to travel in only one direction. If the workpiece moves backwards, such as during a kickback, the pawls will dig into the workpiece to slow or stop it.

To work properly, the pawls must return to their resting position after pivoting (see **Figure 55**), and they must NOT be engaged in the arresting hooks.

If the pawls fail to return to the resting position, the pivot area may need to be cleaned or the spring may have been dislodged or broken and will need to be fixed/replaced.

### Disabling Pawls

You might disable the pawls if you are concerned about them scratching a delicate workpiece, or if you believe that they will obstruct a narrow workpiece and cause feeding difficulty or loss of control. Use your best judgment before retracting the pawls, as they are provided for your safety.

To disable pawls, do these steps:

1. DISCONNECT MACHINE FROM POWER!
2. Rotate one or both arresting hooks downward, then place pawls on each of the hooks (see **Figure 56**).

### Enabling Pawls

To enable the pawls, lift up on each pawl and move them outward and down until they both touch the table surface, as shown in **Figure 55**.

## When to Use Blade Guard

The blade guard assembly **MUST** always be installed on the saw for all normal through cuts (those where the blade cuts all the way through the thickness of the workpiece). If the blade guard is removed for specific operations, always immediately replace it after those operations are complete.

## When Not to Use Blade Guard

The blade guard cannot be used on any non-through cuts (those in which the blade does not cut all the way through the thickness of the workpiece).

Sometimes the blade guard or its components can get in the way when cutting very narrow workpieces or other specialized cuts. Because the blade guard is provided to decrease your risk of injury, it should not be used if it gets in the way of making a safe cut. Use good judgment!

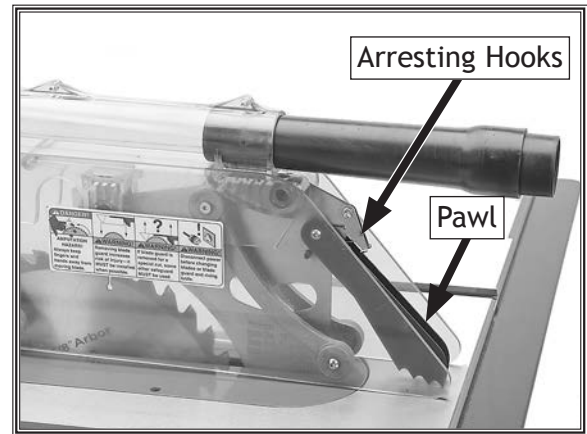


Figure 55. Pawls in resting position.

**⚠ CAUTION**

We do not recommend disabling pawls during normal operations unless absolutely necessary. In most situations, disabling pawls will increase your risk of serious personal injury in event of a kickback.

**⚠ CAUTION**

The pawls are sharp and can lacerate fingers or hands. Use caution, and wear leather gloves when handling the pawls to reduce risk of injury.

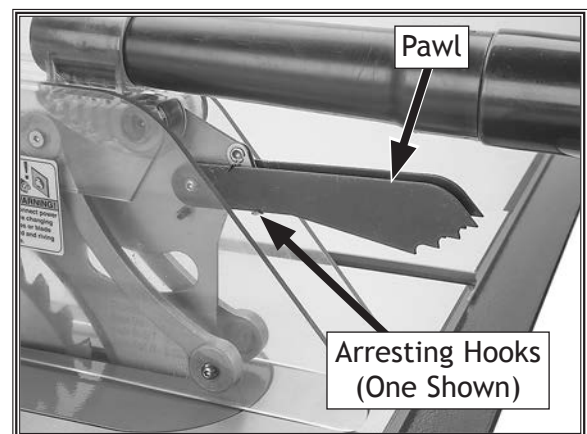


Figure 56. Pawls disabled.

**NOTICE**

Whenever the blade guard cannot be used the riving knife must be installed.

OPERATIONS

# Riving Knife

The riving knife works in the same manner as the spreader on the blade guard assembly. It is a metal plate that prevents the newly cut workpiece from pinching the backside of the blade and causing kickback.

The key difference between the spreader and the riving knife is that the riving knife mounts below the blade's highest point of rotation, as shown in **Figure 57**.

The height difference between the riving knife and the blade allows the workpiece to pass over the blade during non-through cuts (those in which the blade does not cut all the way through the thickness of the workpiece).

The riving knife acts as a barrier behind the blade to reduce the risk of hands being pulled into the blade if a kickback occurs.

The riving knife must be kept within the range shown in **Figure 58**. Therefore, we only recommend using a 10" blade for operations that require use of the riving knife.

## How to Install Riving Knife

The riving knife is installed in a similar manner to the blade guard and spreader. Refer to **Blade Guard Assembly** on **Page 37** for installation instructions.

## When to Use Riving Knife

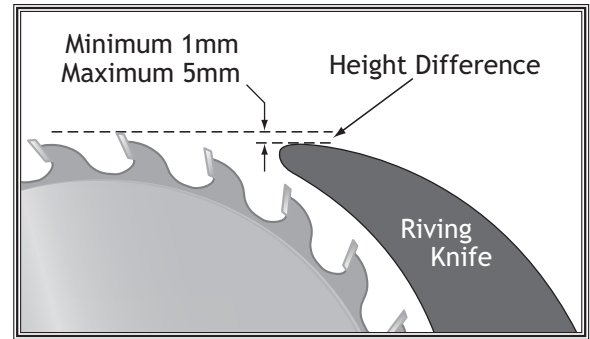
Use the riving knife for all non-through cuts made with a standard table saw blade (i.e., dados or rabbet cuts, and when using a tenoning jig), or when using a 10" diameter dado blade.

Also, use the riving knife for those special operations where the blade guard or its components get in the way of safe operation, such as with very narrow cuts.

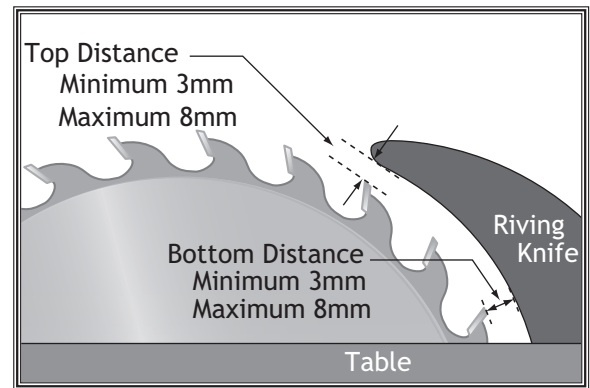
## When Not to Use Riving Knife

**DO NOT** use the riving knife with a dado blade that has a diameter smaller than 10". Otherwise, the riving knife height will exceed the blade height and the workpiece will hit the riving knife during the cut, forcing the operator into a dangerous situation of trying to turn the saw off with the workpiece stuck halfway through the cut.

In addition, although it is possible to use the riving knife for through cutting operations, the blade guard offers far more injury protection and risk reduction than the riving knife. Therefore, **we strongly recommend** you use the blade guard assembly instead of the riving knife for through cuts.



**Figure 57.** Example of height difference between riving knife and blade.



**Figure 58.** Example of allowable top and bottom distances between riving knife and blade.

## **WARNING**

To ensure riving knife works safely, it **MUST** be aligned with and correctly adjusted to blade. Refer to **Page 72** to check or adjust riving knife alignment.

# Ripping

Ripping means cutting with the grain of a natural wood workpiece. In man-made materials such as MDF or plywood, ripping simply means cutting lengthwise.

To make a rip cut, do these steps:

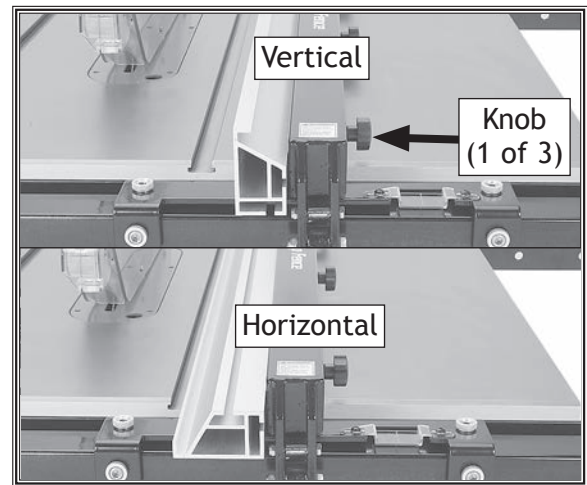
1. Review **Preventing Kickback** on **Page 11** and take necessary precautions to reduce likelihood of kickback.
2. If using natural wood, joint one long edge of workpiece on a jointer.
3. **DISCONNECT MACHINE FROM POWER!**
4. Ensure that blade guard/spreader is installed.
5. Loosen fence knobs (see **Figure 59**), remove rip fence, then re-install in vertical position for thicker workpieces, or in horizontal position for thinner workpieces and angled cuts where blade is tilted over fence. Lift fence up and tighten each fence knob.
6. Set fence to desired width of cut on scale.
7. Adjust blade height so highest saw tooth protrudes no more than  $\frac{1}{4}$ " above workpiece.
8. Set up safety devices such as featherboards (see **Figure 60**) or other anti-kickback devices, making sure no safety devices are contacting blade.
9. Plug saw into power source, turn it **ON**, and allow it to reach full speed.

**Note:** *Jointed edge of workpiece must slide against fence during cutting operation.*

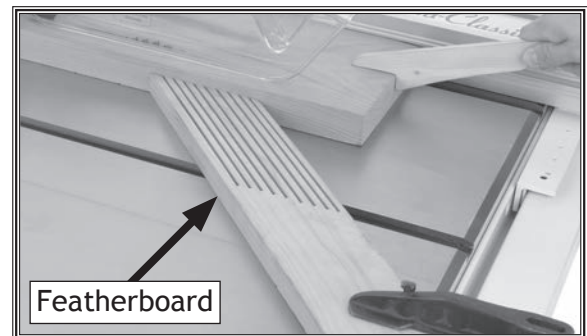
10. Use push stick to feed workpiece through saw blade, as shown in **Figure 59**, until workpiece is completely beyond saw blade.

**⚠ CAUTION**

Serious injury can be caused by kickback. Kickback is a high-speed ejection of stock from table saw toward an operator. The operator or bystanders may be struck by flying stock, or the operator's hands can be pulled into blade during kickback.



**Figure 59.** Rip fence positions.



**Figure 60.** Typical ripping operation.

**⚠ WARNING**

Turn saw **OFF** and allow blade to come to a complete stop before removing cutoff piece. Failure to follow this warning could result in severe cuts or amputation.

**⚠ WARNING**

Keep blade guard installed and in down position. Failure to do this could result in serious personal injury or death.

# Crosscutting

"Crosscutting" means cutting across the grain of a natural wood workpiece, usually with a miter saw. In other man-made materials, such as MDF or plywood, crosscutting means cutting across the width of the workpiece.

To make a crosscut using miter gauge, do these steps:

1. DISCONNECT MACHINE FROM POWER!
2. Ensure that blade guard/spreader is installed.
3. To avoid kickback, move rip fence aside and position miter gauge, adjusted to 90°, in a miter slot.
4. Adjust blade height so teeth protrude no more than 1/4" above workpiece.
5. Slide miter gauge near blade and adjust workpiece so blade will cut on waste side of line.
6. Plug in table saw, turn it **ON**, and allow it to reach full speed.
7. Hold workpiece firmly against face of miter gauge (as shown in **Figure 61**), and ease it through blade until workpiece is completely past saw blade.



Figure 61. Typical crosscutting operation.

## WARNING

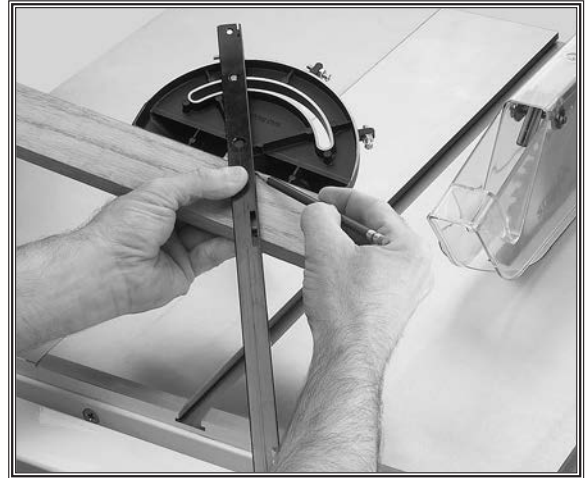
Turn saw **OFF** and allow blade to come to a complete stop before removing cutoff piece. Failure to follow this warning could result in severe cuts or amputation.

## Miter Cuts

A miter cut is an angled crosscut. Miters are usually cut in the same manner as crosscuts, using the miter gauge and a predetermined mark on the workpiece.

To perform a miter cut, do these steps:

1. Ensure that blade guard/spreader is installed.
2. Determine angle of cut. If angle needs to be very precise, use a protractor to set miter gauge to blade.
3. Place face of miter gauge against edge of workpiece and place bar across face of workpiece. Use bar as a guide to mark your cut, as shown in **Figure 62**.
4. Place miter gauge back into slot and hold workpiece firmly against miter gauge body. Slide miter gauge near blade and adjust workpiece so blade will cut on waste side of line.
5. Proceed to make cut in same manner as described in **Crosscutting** instructions.



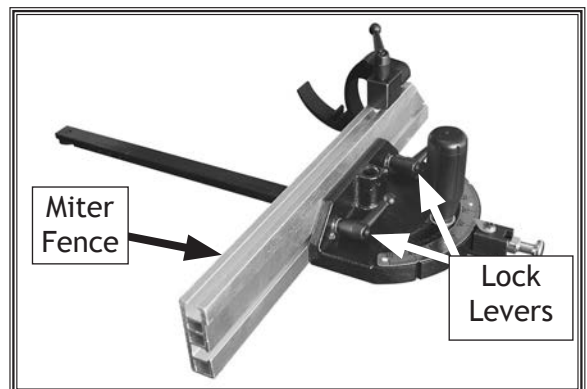
**Figure 62.** Example of marking miter line.

## Miter Fence

The miter fence provides greater workpiece support than the miter gauge alone, especially for longer workpieces.

Simply loosen the lock levers shown in **Figure 63**, slide the miter fence in the needed direction for the cutting operation, then tighten the lock levers.

**IMPORTANT:** *Make sure the miter fence does not contact the blade guard or blade when moved through its full range of travel.*

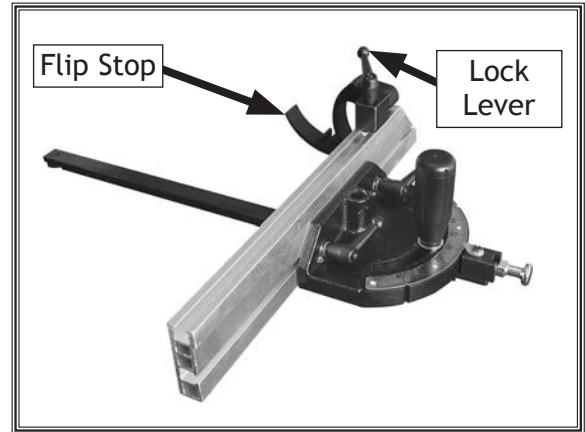


**Figure 63.** Location of lock levers on miter fence.

## Flip Stop

The flip stop can be positioned anywhere along the top of the miter fence and secured in place with a lock lever (see **Figure 64**), the same distance away from the blade as your desired width of cut.

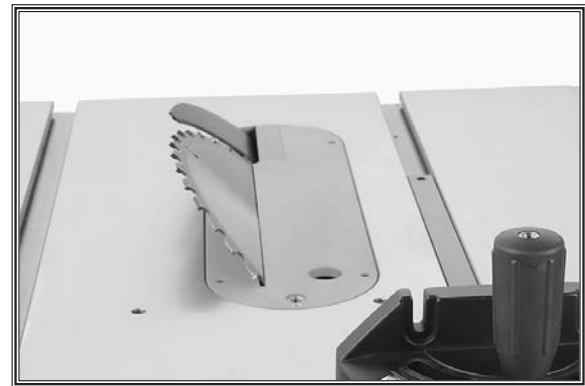
The flip stop can be used in the down position to make multiple cuts of the same width. It can be pivoted (hence the name “flip”) out of the way to allow longer workpieces to be cut, then pivoted back down to make additional cuts at the specified cutting width.



**Figure 64.** Location of flip stop lock lever.

## Blade Tilt/Bevel Cuts

When the blade tilt collar bolts are properly adjusted (as described starting on **Page 68**), the blade tilt handwheel allows the operator to tilt the blade to the left, between 0° and 45°. This is used most often when cutting bevels, compound miters, or chamfers. **Figure 65** shows an example of the blade when tilted to 45°.



**Figure 65.** Blade tilted to 45° for bevel cutting on a typical table saw.

# Dado Cutting

Commonly used in furniture joinery, a dado is a straight channel cut in the face of the workpiece. Dadoes are "non-through" cuts that can be made with a dado blade or a standard saw blade. **Figure 66** shows a cutaway view of a dado cut being made with a dado blade.

The Model W1851 can accommodate dado blades up to 10" in diameter. We recommend keeping the riving knife installed if using a 10" diameter dado blade. Although the riving knife thickness will not match the dado blade thickness, it will provide a barrier behind the blade, which can reduce the risk of hands being pulled into the blade if kickback occurs.

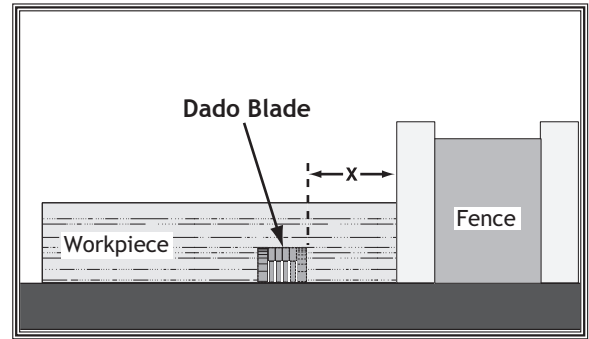
DO NOT use the riving knife if you install a dado blade smaller than 10" in diameter. The riving knife height is not compatible with blades less than 10" in diameter.

## Installing Dado Blade

1. DISCONNECT MACHINE FROM POWER!
2. Remove table insert, blade guard assembly or riving knife, arbor nut, flange, and saw blade.
3. Attach and adjust dado blade system according to dado blade manufacturer's instructions, and secure with included dado blade flange and arbor nut.

**Note:** *The dado blade flange is thinner than the main saw blade flange. Make sure you use the correct flange when installing the dado blade.*

4. Install dado table insert.



**Figure 66.** Example of a dado being cut with a dado blade.

## WARNING

**DO NOT** make through cuts with a dado blade. The extra width of a dado blade will increase risk of kickback during a through cut. Dado blades are only intended for non-through cuts. Failure to heed this warning could result in serious injury.

## Cutting Dados with a Dado Blade

Because dado blades are much wider than standard blades, they place a greater amount of force against the workpiece when cutting. This additional force increases the risk of kickback, requiring the operator to take additional steps when cutting to keep their injury risk at an acceptable level.

**⚠ WARNING**

Never try to cut a warped board by pushing it flat against the table. If kickback occurs, your hand could be pulled into blade, resulting in severe cuts or amputation.

**⚠ WARNING**

Dado blades have a higher risk of kickback than normal blades because their larger size applies stronger forces to the workpiece. This risk increases relative to depth and width of cut. To minimize your risk of serious personal injury, ensure that stock is flat and straight, and make multiple light cuts (rather than one deep cut) to achieve desired cutting depth.

Figure 67 demonstrates the sequential process of making multiple, light cuts that get progressively deeper. The actual number of cuts used should be determined by workpiece hardness, total dado depth, and feed rate. In general, if you hear the motor slow down during the cut, you are cutting too deep or feeding too fast. Slow down!

To cut dado with dado blade, do these steps:

1. DISCONNECT MACHINE FROM POWER!
2. Adjust dado blade to desired depth of cut.
3. Adjust distance between fence and inside edge of blade, as shown in Figure 66 on Page 45, to dado length of a workpiece.
  - If dadoing across workpiece, use miter gauge and carefully line up desired cut with dado blade. DO NOT use fence in combination with miter gauge.
4. Reconnect saw to power source.
5. Turn saw *ON*. Blade should run smoothly, with no vibrations.
6. When blade has reached full speed, perform test cut with scrap piece of wood.
  - If cut is satisfactory, repeat cut with actual workpiece.

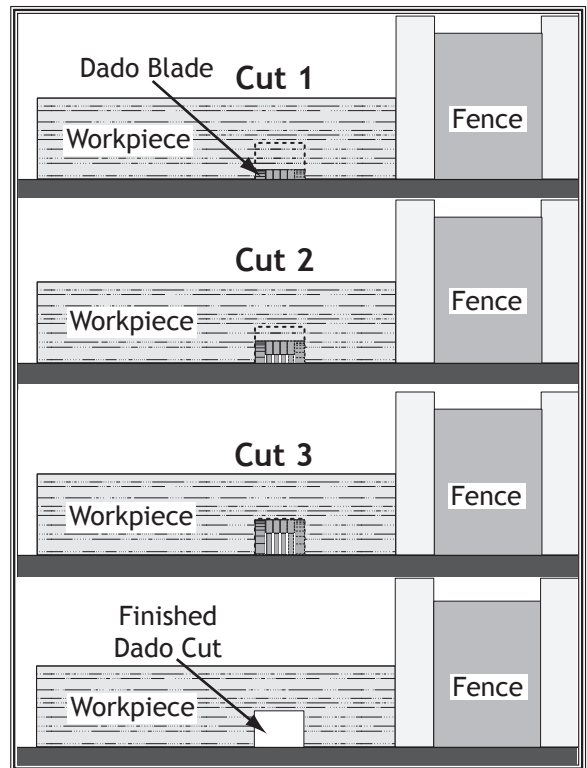


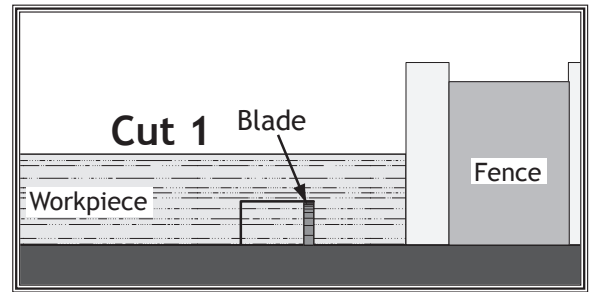
Figure 67. Example of dado being cut with multiple light cuts, instead of one deep cut.

## Cutting Dadoes with a Standard Blade

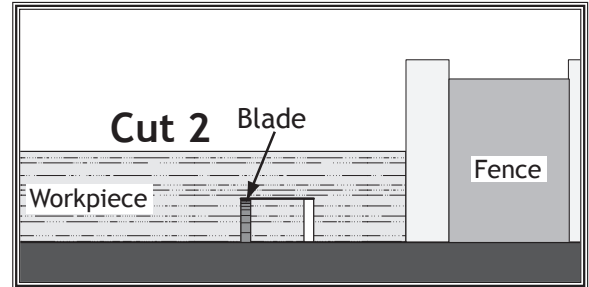
A ripping blade (described on [Page 33](#)) is typically the best blade to use when cutting dadoes with a standard blade because it removes sawdust very efficiently.

To use standard saw blade to cut dadoes, do these steps:

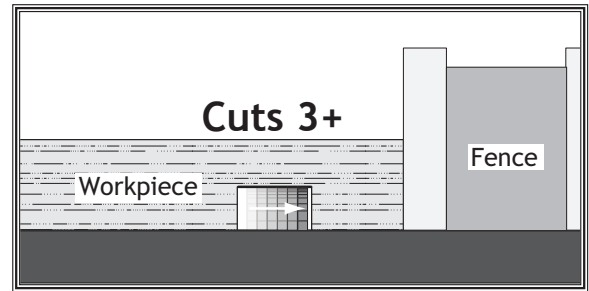
1. DISCONNECT MACHINE FROM POWER!
2. Mark width of dado cut on workpiece. Include marks on edge of workpiece so cut path can be aligned when workpiece is lying on table.
3. Raise blade up to desired depth of cut (depth of dado channel desired).
4. Set saw up for type of cut you need to make, depending on whether it is a rip cut ([Page 41](#)) or crosscut ([Page 42](#)).
5. Align blade to cut one side of dado, as shown in [Figure 68](#).
6. Reconnect saw to power source and turn saw **ON**. Allow blade to reach full speed, then perform cutting operation.
7. Repeat cutting operation on other side of dado, as shown in [Figure 69](#).
8. Make additional cuts (see [Figure 70](#)) in center of dado to clear out necessary material. Dado is complete when channel is completely cleared out.



**Figure 68.** First cut for a single-blade dado.



**Figure 69.** Second cut for a single-blade dado.



**Figure 70.** Additional single-blade dado cuts.

# Rabbet Cutting

Commonly used in furniture joinery, a rabbet cut is an L-shaped groove cut in the edge of the workpiece. Rabbets can be cut with either a dado blade or a standard saw blade.

Rabbet cutting along the edge of a workpiece with a dado blade requires a sacrificial fence (see **Figure 71**). Make the sacrificial fence the same length as the fence and  $\frac{3}{4}$ " thick. Attach it to the fence with screws or clamps, making sure they are all secure and tight. Raise the blade into the sacrificial fence to the height and rabbet width needed.

When using a dado blade, the included dado table insert must be installed and used during rabbeting operations.

## Cutting Rabbets with a Dado Blade

1. DISCONNECT MACHINE FROM POWER!
2. Lower dado blade all the way down.
3. Secure sacrificial fence with clamps to fence.

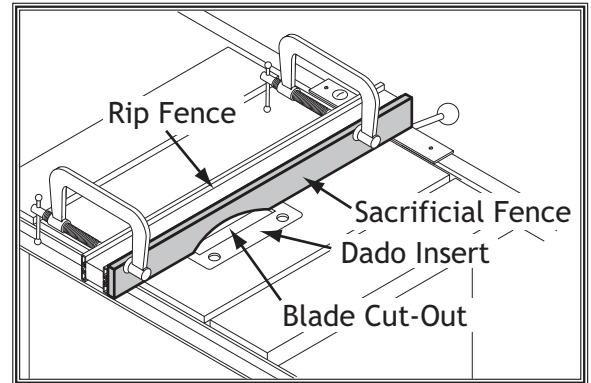
**Note:** Be sure to allow adequate clearance below clamps for workpiece to travel freely.

4. Position fence so dado blade protrudes beyond fence the same amount as desired width of rabbet (see **Figure 72**).
5. Mark a reference line on the face of the sacrificial fence indicating approximate rabbet depth.
6. Secure fence, reconnect machine to power, and turn machine **ON**.
7. Slowly raise dado blade into sacrificial fence slowly until it reaches line marked previously on sacrificial fence.
8. Perform test cut on a scrap piece of wood to verify rabbet height and width.

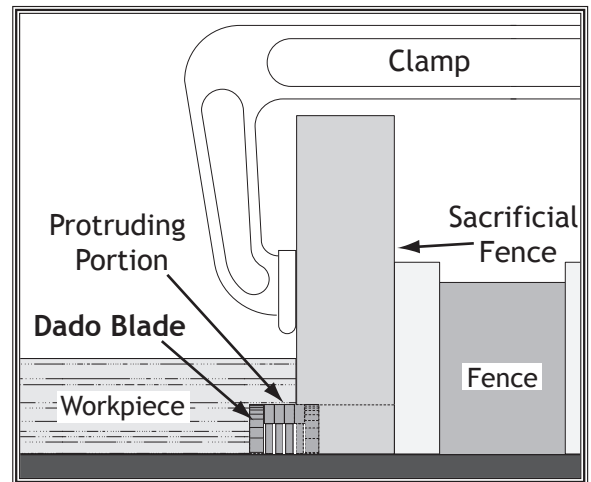
—If cut is satisfactory, repeat cut with workpiece.

## ⚠️ WARNING

Dado blades have a higher risk of kickback than normal blades because their larger size applies stronger forces to the workpiece. This risk increases relative to the depth and width of the cut. To minimize your risk of serious personal injury, ensure that stock is flat and straight, and make multiple light cuts (rather than one deep cut) to achieve the desired cutting depth.



**Figure 71.** Example of sacrificial fence.



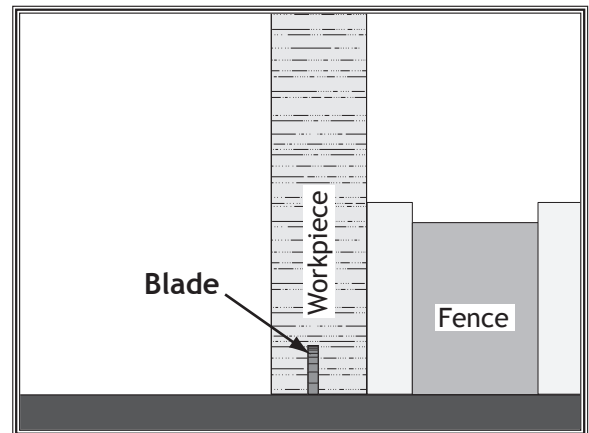
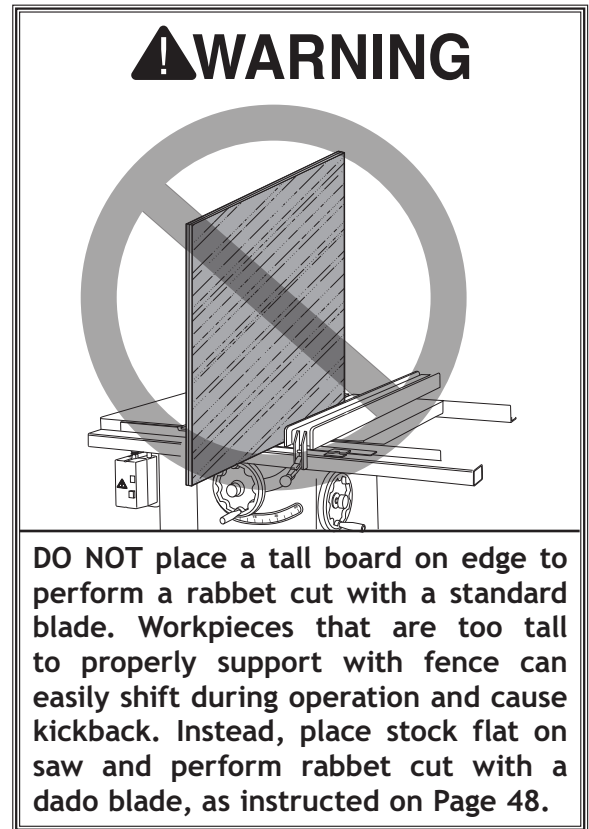
**Figure 72.** Rabbet cutting.

## Cutting Rabbets with a Standard Blade

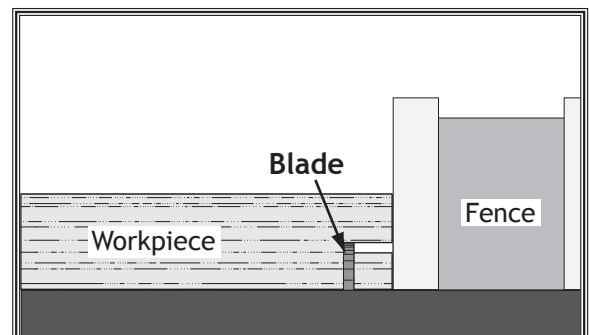
A ripping blade is typically the best blade to use for cutting rabbets when using a standard blade because it removes sawdust very efficiently. (See **Page 33** for blade details.) Also, a sacrificial fence is not required when cutting rabbets with a standard blade.

To cut rabbets with standard blade, do these steps:

1. DISCONNECT MACHINE FROM POWER!
2. Ensure that riving knife and standard table insert are installed.
3. Mark width of rabbet cut on edge of workpiece, so you can clearly identify intended cut while it is laying flat on saw table.
4. Raise blade up to desired depth of cut (depth of rabbet channel desired).
5. Stand workpiece on edge, as shown in **Figure 73**, then adjust fence so blade is aligned with inside of your rabbet channel.
  - If workpiece is very tall, or is unstable when placed against fence, lay it flat on table and use a dado blade to perform rabbet cut.
6. Reconnect saw to power source, then perform cut.
7. Lay workpiece flat on table, as shown in **Figure 74**, adjust saw blade height to intersect with first cut, then perform second cut to complete rabbet.



**Figure 73.** Example of rabbet cutting with a standard blade.



**Figure 74.** Example of second cut to create a rabbet.

OPERATIONS

# Resawing

Resawing is the process of cutting a thick piece of stock into one or more thinner pieces.

**IMPORTANT:** Although resawing can be done with a table saw, *we strongly recommend that you use a bandsaw instead.* A bandsaw is the ideal machine for resawing, and resawing with one is fairly easy and safe. A table saw is not intended for resawing, and resawing with one is difficult and dangerous due to the increased risk of kickback from binding and deep cuts, and the increased risk of injury from having to remove the guard.

If you insist on resawing with a table saw, DO NOT do so without using a resaw barrier and wearing a full face shield. The following instructions describe how to build a resaw barrier and add an auxiliary fence to your standard fence, to reduce the risk injury from resawing on a table saw.

**Note:** To determine the maximum resawing height for this table saw, find the maximum blade height, then double it and subtract  $\frac{1}{8}$ ".

## Making a Resaw Barrier

When resawing, the resaw barrier (see **Figure 75**) acts in tandem with the rip fence to provide tall support for the workpiece. This minimizes the probability of it binding against the blade and causing kickback.

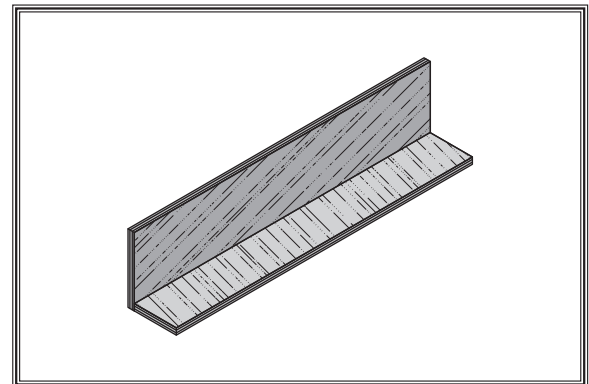
| Tools Needed:                                      | Qty         |
|--|-------------|
| Table Saw .....                                    | 1           |
| Jointer and Planer .....                           | Recommended |
| Clamps .....                                       | 2 Minimum   |
| Drill .....  | 1           |
| Drill Bits $\frac{1}{8}$ ", $\frac{9}{64}$ " ..... | 1 Each      |
| Countersink Bit .....                              | 1           |

| Components Needed for Resaw Barrier:                             | Qty       |
|--|-----------|
| Wood* $\frac{3}{4}$ " x $5\frac{1}{2}$ " x Length of Fence ..... | 1         |
| Wood* $\frac{3}{4}$ " x 3" x Length of Fence.....                | 1         |
| Wood Screws #8 x 2" .....  | 4         |
| Wood Glue .....  | As Needed |

\* Only use furniture-grade plywood, kiln dried hardwood, or HDPE plastic to prevent warping.

**! CAUTION**

Resawing operations require proper procedures to avoid serious injury and prevent kickback. Any tilting or movement of workpiece away from fence will likely cause kickback. Be certain that stock is flat and straight. Failure to follow these warnings could result in serious personal injury or amputation.



**Figure 75.** Example of resaw barrier.

OPERATIONS

To build a resaw barrier, do these steps:

1. Cut your wood pieces to specified size. If you are using hardwood, cut pieces oversize, then joint and plane them to correct size to make sure they are square and flat.
2. Pre-drill and countersink four holes approximately  $\frac{3}{8}$ " from bottom of  $5\frac{1}{2}$ " tall wood piece.
3. Glue end of 3" board, then clamp boards at a 90° angle with larger board in vertical position, as shown in **Figure 76**, and fasten them together with wood screws.

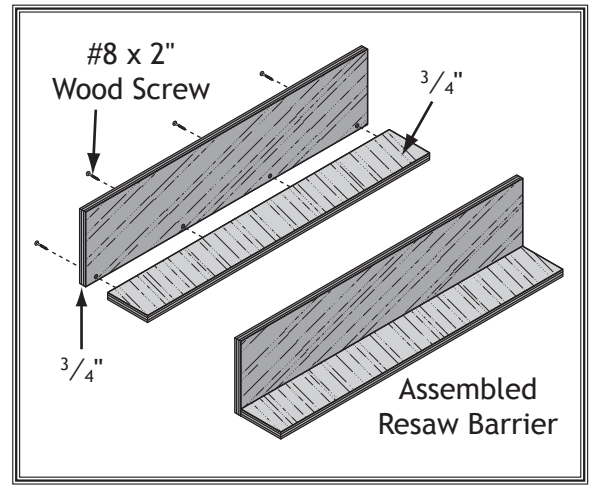


Figure 76. Resaw barrier.

### Making Auxiliary Fence

An auxiliary fence is necessary if you are resawing a workpiece that is taller than it is wide. The fence should be no less than  $\frac{1}{2}$ " a than the board to be resawn.

The fence should be similar to the one in **Figure 77** when installed.

#### Tools Needed:

|                                  | Qty |
|----------------------------------|-----|
| Clamps .....                     | 2   |
| Drill .....                      | 1   |
| Drill Bit $\frac{7}{32}$ " ..... | 1   |
| Countersink Drill Bit.....       | 1   |
| Hex Wrench 5mm .....             | 1   |
| Ruler .....                      | 1   |

#### Components Needed:

|   |   |
|---|---|
| Flat Head Cap Screws M6-1 x (Auxiliary Fence Width + Fence Tube Width)..... | 3 |
| Wood* $\frac{3}{4}$ " x 4" x Length of Fence.....                           | 1 |

\*Only use furniture-grade plywood, kiln-dried hardwood, or HDPE plastic to prevent warping. Ensure the flat head cap screw heads do not project beyond the auxiliary fence. Countersink holes in fence to install screws properly.

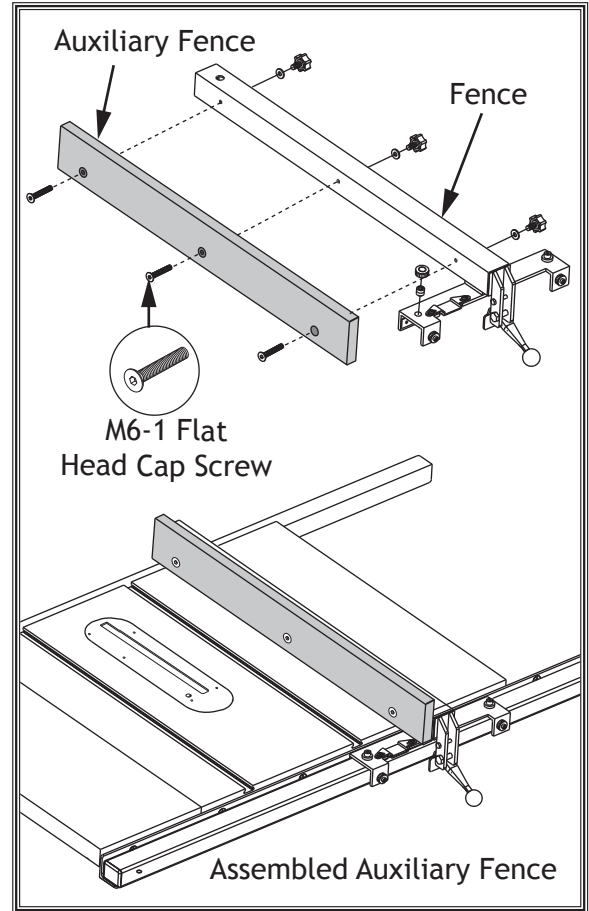
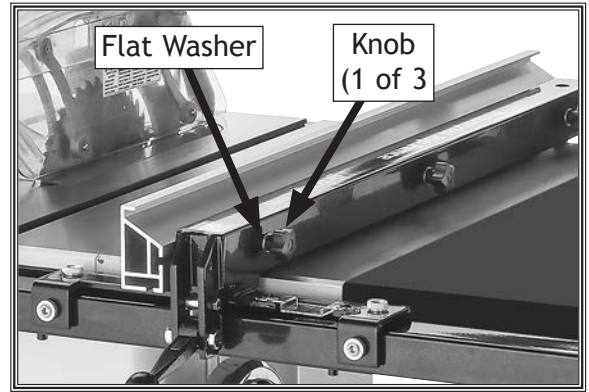


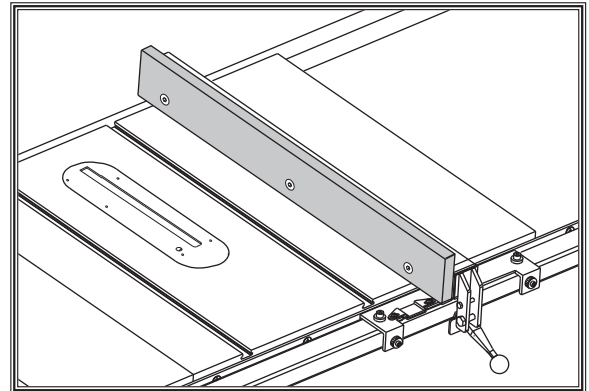
Figure 77. Example of auxiliary fence attached to Model W1851 fence face.

To install an auxiliary fence, do these steps:

1. Cut auxiliary fence board to size. If you are using hardwood, cut board oversize, then joint and plane board to correct size to make sure board is square and flat.
2. Unthread (3) knobs and (3) flat washers securing fence face to fence tube shown in **Figure 78**, then remove fence.
3. Place auxiliary fence board against fence tube. Place a thin metal shim (such as a ruler) between table and bottom of auxiliary fence board to ensure adequate clearance between fence board and table. Clamp in position.
4. Mark location of three mounting holes on auxiliary fence and remove auxiliary fence board from fence tube.
5. Using  $\frac{7}{32}$ " drill bit, drill mounting holes in auxiliary fence board. Countersink holes  $\frac{1}{16}$ " deep so head of flat head cap screws sits slightly beneath face of auxiliary fence board.
6. Insert (3) flat head cap screws through holes in auxiliary fence board (see **Figure 77** on **Page 51**) and secure with knobs and flat washers removed earlier. The end result should be similar to **Figure 79**.



**Figure 78.** Location of knobs and flat washers securing fence to fence tube.



**Figure 79.** Example auxiliary fence attached to included fence.

## Resawing Operations

The table saw motor is pushed to its limits when resawing. If the motor starts to bog down, slow down your feed rate. Motor overloading and blade wear can be reduced by using a ripping blade. Ripping blades are designed to clear the sawdust quickly.

### Components Needed for Resawing:

|                                   |   |
|-----------------------------------|---|
| Zero-clearance Table Insert ..... | 1 |
| Ripping Blade 10" .....           | 1 |
| Clamps .....                      | 2 |
| Shop-Made Auxiliary Fence .....   | 1 |
| Shop-Made Resaw Barrier .....     | 1 |

To perform resawing operations, do these steps:

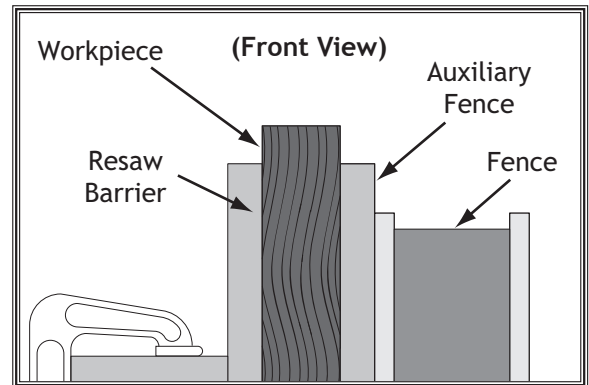
1. DISCONNECT MACHINE FROM POWER!
2. Remove standard table insert and blade guard assembly.
3. Install ripping blade, install riving knife, lower blade below table surface, then install zero-clearance table insert.
4. Attach auxiliary fence and set it to desired width.

**Note:** When determining correct width, don't forget to account for blade kerf and inaccuracy of fence scale while auxiliary fence is installed.

5. Place workpiece against auxiliary fence and slide resaw barrier against workpiece, as shown in **Figure 80**. Now clamp resaw barrier to top of table saw at both ends, making sure it is parallel to fence.
6. Lower blade completely below table-top, and slide workpiece over blade to make sure it moves smoothly and fits between resaw barrier and fence.
7. Raise blade approximately 1 inch, or close to half the height of workpiece, whichever is less.

**⚠ WARNING**

You may experience kickback during this procedure. Stand to the side of the blade and wear safety glasses and a full face shield to prevent injury when resawing.



**Figure 80.** Example illustration of a resaw setup.

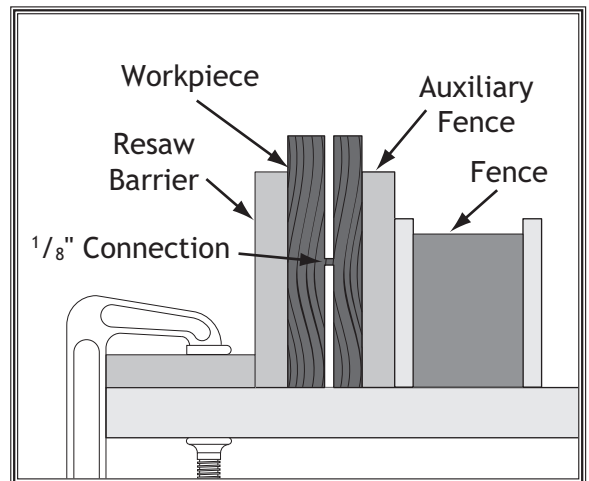
8. Plug in table saw, turn it **ON**, and use a push stick or push block to feed workpiece through blade, using a slow and steady feed rate.

*Note: We recommend making a series of light cuts that get progressively deeper, to reduce the chance of stalling the motor.*

9. Flip workpiece end for end, keeping same side against fence, and run workpiece through blade again.
10. Repeat **Steps 7-9** until blade is close to half the height of board to be resawn. The ideal completed resaw cut will leave an  $\frac{1}{8}$ " connection when resawing is complete, as shown in **Figure 81**. Leaving an  $\frac{1}{8}$ " connection will reduce risk of kickback.
11. Turn **OFF** table saw, then separate parts of workpiece and hand plane remaining ridge to remove it.
12. When finished resawing, remove resaw barrier and auxiliary fence, then re-install blade guard/spreader or riving knife and standard table insert.

**⚠ WARNING**  
 The danger of kickback increases relative to the depth of a cut. Reduce risk of kickback by making multiple passes to achieve the desired depth of cut. Failure to follow these warnings could result in serious personal injury.

**⚠ WARNING**  
 Always use push sticks or push paddles to increase safety and control during operations which require that blade guard and spreader must be removed from saw. **ALWAYS** replace blade guard after resawing is complete.



**Figure 81.** Ideal completed resaw operation.

# SHOP-MADE SAFETY ACCESSORIES

## Featherboards

Easily made from scrap stock, featherboards provide an added degree of protection against kickback, especially when used together with push sticks. They also maintain pressure on the workpiece to keep it against the fence or table while cutting, which makes the operation easier and safer because the cut can be completed without the operator's hands getting near the blade. The angled ends and flexibility of the fingers allow the workpiece to move in only one direction.

### Making a Featherboard

This sub-section covers the two basic types of featherboards: 1) Those secured by clamps, and 2) those secured with the miter slot.

#### Material Needed for Featherboard:

- Hardwood  $\frac{3}{4}$ " x 3" x 10" (Minimum) .....1
- Hardwood  $\frac{3}{4}$ " x 6" x 28" (Maximum).....1

#### Additional Material Needed for Mounting Featherboard:

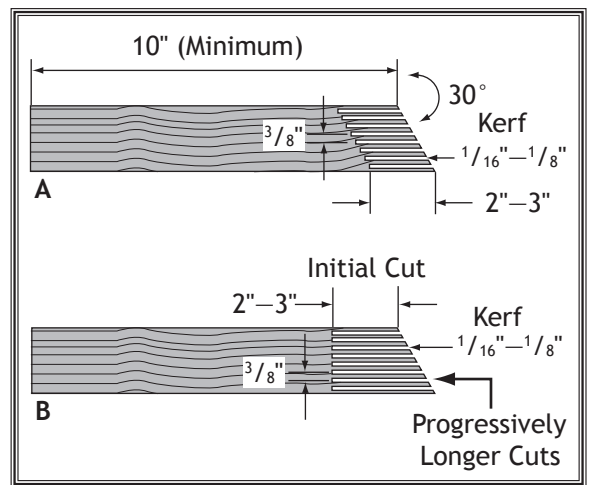
- Hardwood  $\frac{3}{8}$ " x (Miter Slot Width) x 5"L .....1
- Wing Nut  $\frac{1}{4}$ "-20.....1
- Flat Head Screw  $\frac{1}{4}$ "-20 x 2" .....1
- Flat Washer  $\frac{1}{4}$ "-20 .....1

To make a featherboard, do these steps:

1. Cut a hardwood board that is approximately  $\frac{3}{4}$ " thick to size. The length and width of the board can vary according to your design. Most featherboards are 10"-28" long and 3"-6" wide. Make sure wood grain runs parallel with length of featherboard, so fingers you will create in **Step 3** will bend without breaking.
2. Cut 30° angle at one end of board.
3. Make a series of end cuts with the grain  $\frac{3}{8}$ "- $\frac{1}{4}$ " apart and 2"-3" long, as shown in **Figure 82** (A). Alternatively, start cuts at 2"-3" deep, then make them progressively deeper, as shown in **Figure 82** (B).

**⚠ CAUTION**

We recommend using a bandsaw for making fingers in the next step because it tends to be safer. A table saw can be used, but it will over-cut the underside of the ends, produce a thicker kerf, and require you to stop the blade half-way through the cut, which can be dangerous.



**Figure 82.** Patterns for making featherboards.

**IMPORTANT:** Cuts made across grain result in weak fingers that easily break when flexed. When made correctly, fingers should withstand flexing from moderate pressure. To test finger flexibility, push firmly on ends with your thumb. If fingers do not flex, they are likely too thick (cuts are too far apart).

**NOTICE**

Only *Steps 1-3* are required to make a clamp-mounted featherboard. Refer to *Page 57* for instructions on clamping.

OPERATIONS

4. Rout a  $\frac{1}{4}$ "- $\frac{3}{8}$ " wide slot 4"-5" long in workpiece and 1"-2" from short end of featherboard (see **Figure 83**).
5. Cut a miter bar approximately 5" long that will fit in table miter slot, as shown in **Figure 84**.

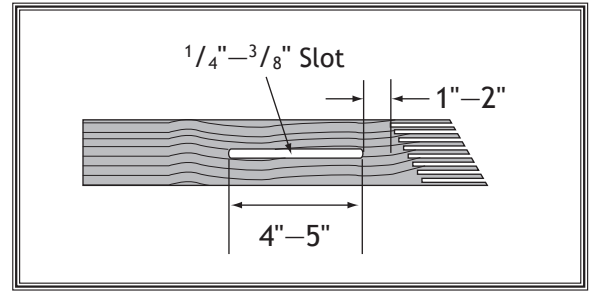
**Tip:** Consider making miter bar longer for larger featherboards—approximately half the length of total featherboard—to support force applied to the featherboard during use.

6. Drill a  $\frac{1}{4}$ " hole in center of bar, then countersink bottom to fit a  $\frac{1}{4}$ "-20 flat head screw.
7. Mark a 4" line through center of countersunk hole in center, then use a jig saw with a narrow blade to cut it out.
8. Assemble miter bar and featherboard with a  $\frac{1}{4}$ "-20 x flat head screw, flat washer, and a wing nut (see **Figure 85**). Congratulations! Your featherboard is complete.

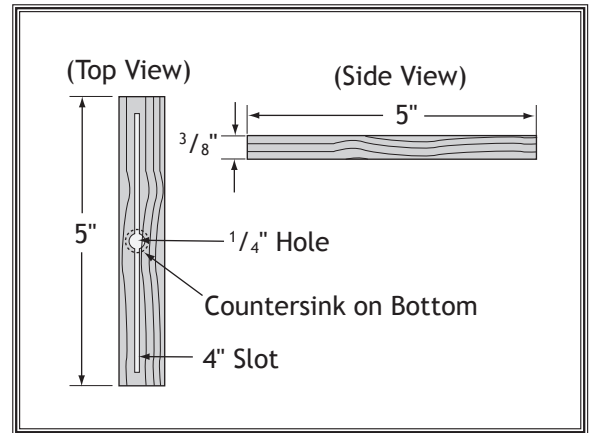
**Note:** The routed slot, countersink hole, and flat head screw are essential for miter bar to clamp into miter slot. When wing nut is tightened, it will draw flat head screw upward into countersunk hole. This will spread sides of miter bar and force them into walls of miter slot, locking featherboard in place.

**Tip:** The length of the flat head screw depends on the thickness of the featherboard—though  $1\frac{1}{2}$ " to 2" lengths usually work.

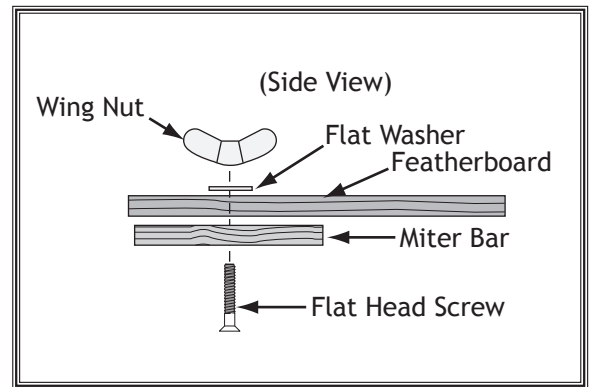
9. Now, proceed to **Mounting Featherboard in Miter Slot on Page 57**.



**Figure 83.** Slot routed in featherboard.



**Figure 84.** Miter bar pattern.



**Figure 85.** Assembling miter slot featherboard components.

## Mounting Featherboard w/Clamps

1. Lower saw blade, then adjust fence to desired width and secure it.
2. Place workpiece against fence, making sure it is 1" in front of the blade.
3. Place a featherboard on table away from blade so all fingers point forward and contact workpiece (see **Figure 86**).
4. Secure featherboard to table with a clamp.
5. Check featherboard by pushing it with your thumb to ensure it is secure.
  - If featherboard moves, tighten clamp more.
6. Optional: If cutting long workpieces, it may be beneficial to use another featherboard to keep board firmly against table while feeding.

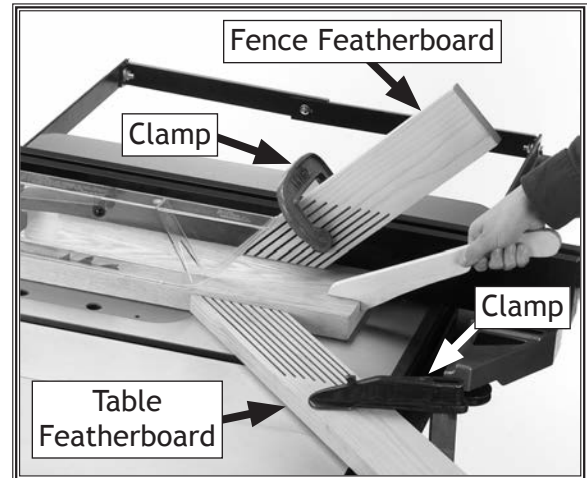
## Mounting Featherboard in Miter Slot

1. Lower saw blade, then adjust fence to desired width and secure it.
2. Place workpiece evenly against fence, making sure it is 1" in front of blade.
3. Slide featherboard miter bar into miter slot, making sure fingers slant toward blade, as shown in **Figure 87**.
4. Position fingered edge of featherboard against edge of workpiece, so that all fingers contact workpiece. Slide featherboard toward blade until first finger is nearly even with end of workpiece, which should be 1" away from blade.
5. Double check workpiece and featherboard to ensure they are properly positioned, as described in **Step 4**. Then secure featherboard to table. Check featherboard by hand to make sure it is tight.

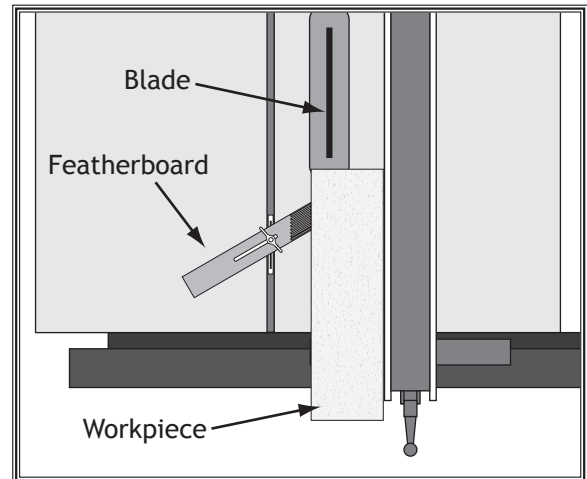
**Note:** *The featherboard should be placed firmly enough against workpiece to keep it against fence but not so tight that it is difficult to feed workpiece.*

## NOTICE

The featherboard should be placed firmly enough against the workpiece to keep it against the fence but not so tight that it is difficult to feed the workpiece.



**Figure 86.** Example of featherboards secured with clamps.



**Figure 87.** Featherboard installed in miter slot and supporting workpiece for ripping cut.

# Push Sticks

When used correctly, push sticks reduce the risk of injury by keeping hands away from the blade while cutting. In the event of an accident, a push stick can also absorb damage that would have otherwise happened to hands or fingers.

## Using a Push Stick

Use push sticks whenever your hands will get within 12" of the blade. To maintain control when cutting large workpieces, start the cut by feeding with your hands then use push sticks to finish the cut, so your hands are not on the end of the workpiece as it passes through the blade.

**Feeding:** Place the notched end of the push stick against the end of the workpiece (see **Figure 89** below), and move the workpiece into the blade with steady downward and forward pressure.

**Supporting:** A second push stick can be used to keep the workpiece firmly against the fence while cutting. When using a push stick in this manner, only apply pressure before the blade; otherwise, pushing the workpiece against or behind the blade will increase the risk of kickback (see "Push Stick Prohibition Zone" in the **Figure** below).

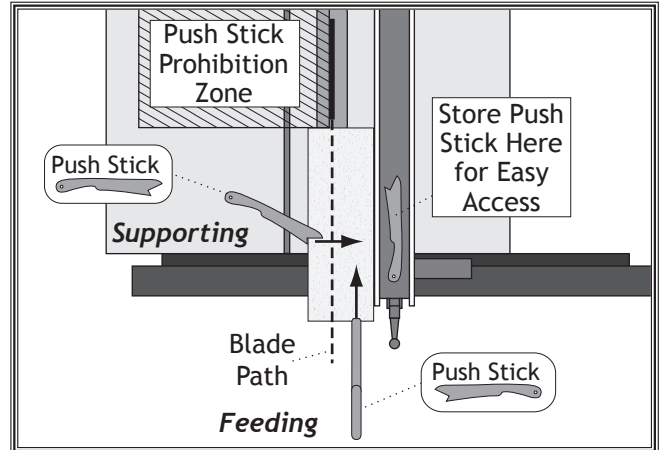


Figure 88. Using push sticks to rip narrow stock.

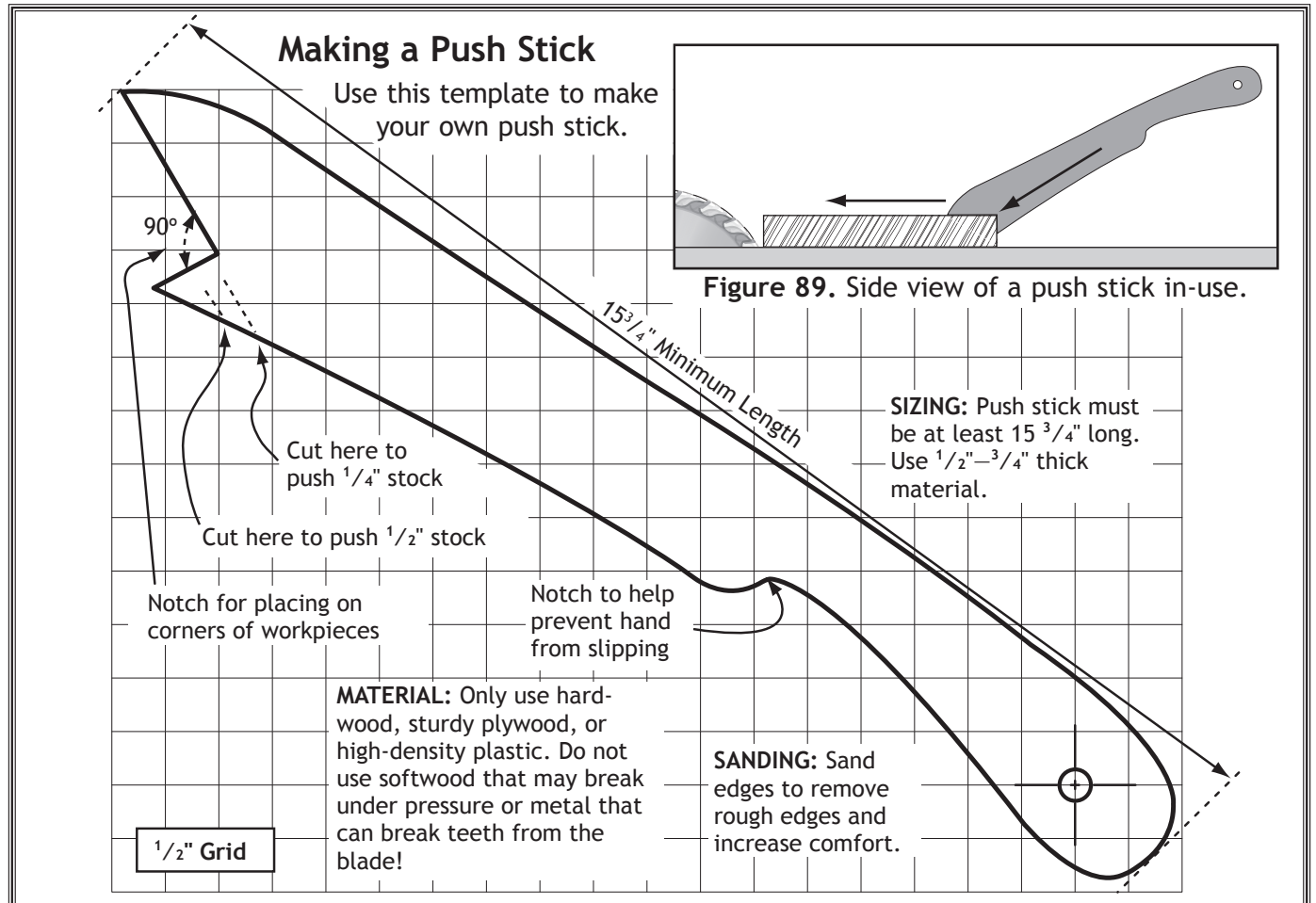


Figure 90. Template for a basic shop-made push stick (not shown at actual size).

# Push Blocks

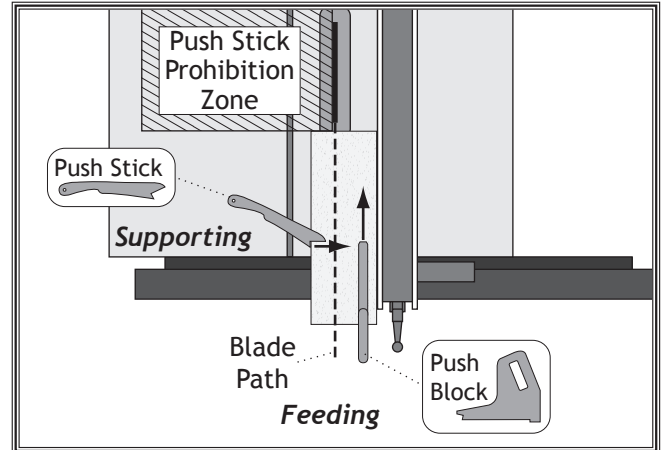
When used correctly, a push block reduces the risk of injury by keeping hands away from the blade while cutting. In the event of an accident, a push block often takes the damage that would have otherwise happened to hands or fingers.

## Using a Push Block

A push block can be used in place of or in addition to a push stick for feeding workpieces into the blade. Due to their design, push blocks allow the operator to apply firm downward pressure on the workpiece that could not otherwise be achieved with a push stick.

The push block design on this page can be used in two different ways (see inset **Figure** below). Typically, the bottom of the push block is used until the end of the workpiece reaches the blade.

The notched end of the push block is then used to push the workpiece the rest of the way through the cut, keeping the operator's hands at a safe distance from the blade. A push stick is often used at the same time in the other hand to support the workpiece during the cut (see **Using a Push Stick** on previous page).



**Figure 92.** Using a push block and push stick to make a rip cut.

### Making a Push Block

Use this template to make your own push block.

**Figure 91.** Side view of a push block in use.

Notch for use as a push stick

**CAUTION:** Bottom of handle must be at least 4" above bottom of push block to keep hand away from blade.

Handle for firm grip

Make push block with 1/2"-3/4" thick material

4"

1/4"-1/2"

Lip for pushing workpiece

9"-10" Minimum Length

**CAUTION:** Only use hardwood, sturdy plywood, or high-density plastic. Do not use softwood that may break under pressure or metal that can break teeth from the blade!

1/2" Grid

**Figure 93.** Template for a shop-made push block (shown at 50% of full size).

# Narrow-Rip Auxiliary Fence & Push Block

There are designs for hundreds of specialty jigs that can be found in books, trade magazines, and on the internet. These types of jigs can greatly improve the safety and consistency of cuts. They are particularly useful during production runs when dozens or hundreds of the same type of cut need to be made. The narrow-rip auxiliary fence and push block system shown in this section is an example of a specialty jig that can be made to increase the safety of very narrow rip cuts.

## Material Needed for Narrow Rip Auxiliary Fence & Push Block

|  |   |
|--|---|
| Hardwood $\frac{3}{4}$ " x 3" x Length of Fence .....              | 1 |
| Plywood $\frac{3}{4}$ " x $5\frac{1}{4}$ " x Length of Fence ..... | 1 |
| Wood Screws #8 x $1\frac{1}{2}$ " .....                            | 8 |

## Material Needed for Push Block

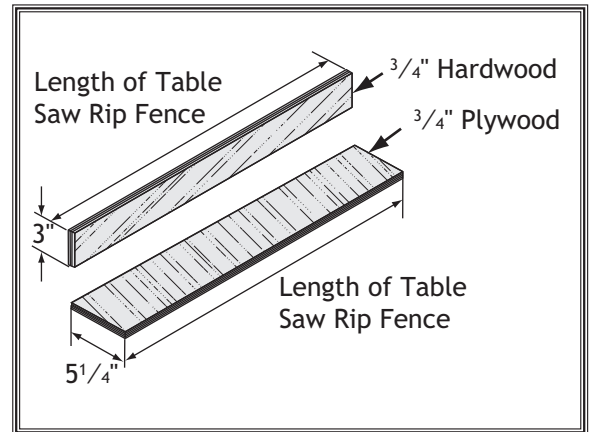
|  |           |
|--|-----------|
| Hardwood or Plywood $\frac{3}{4}$ " x 15" x $5\frac{5}{8}$ " ..... | 1         |
| Hardwood or Plywood $\frac{3}{4}$ " x 10" x 5"-9" .....            | 1         |
| Cyanoacrylate Wood Glue .....                                      | Varies    |
| Wood Screws #8 x $1\frac{1}{2}$ " .....                            | As Needed |

## Making a Narrow-Rip Push Block for an Auxiliary Fence

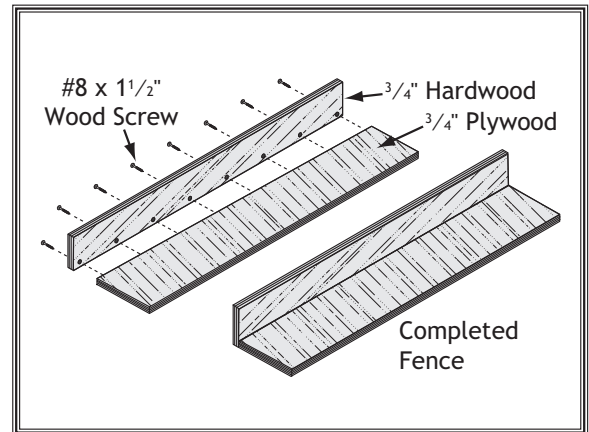
1. Cut a piece of  $\frac{3}{4}$ " thick plywood  $5\frac{1}{4}$ " wide and as long as your table saw fence; cut a piece of  $\frac{3}{4}$ " thick hardwood 3" wide and as long as your table saw fence, as shown in **Figure 94**.

**Note:** We recommend cutting the hardwood board oversize, then jointing and planing it to the correct size to make sure the board is square and flat. Only use furniture-grade plywood or kiln dried hardwood to prevent warping.

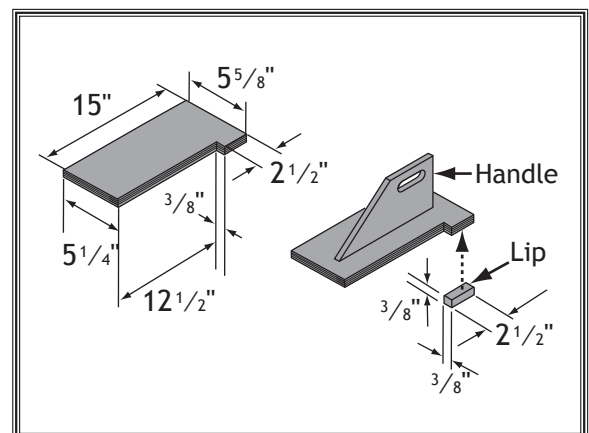
2. Pre-drill and countersink eight pilot holes  $\frac{3}{8}$ " from bottom of 3" wide board, then secure boards together with (8) #8 x  $1\frac{1}{2}$ " wood screws, as shown in **Figure 95**.
3. Using  $\frac{3}{4}$ " material you used in previous steps, cut out pieces for push block per the dimensions shown in **Figure 96**; for handle, cut a piece 10" long by 5"-9" high and shape it as desired to fit your hand.
4. Attach handle to base with #8 x  $1\frac{1}{2}$ " wood screws, and attach lip to base with cyanoacrylate-type wood glue.



**Figure 94.** Auxiliary fence dimension.



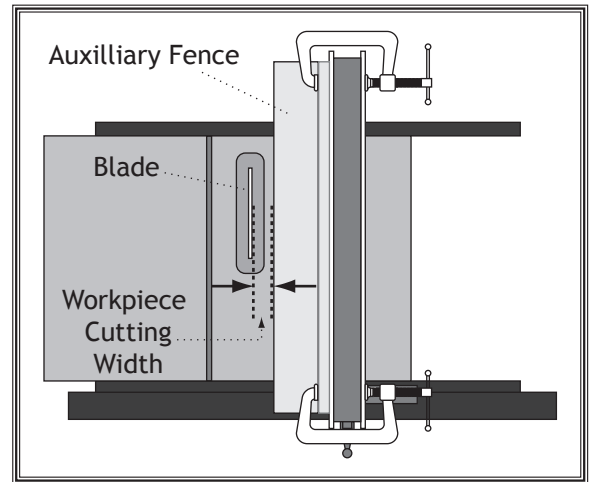
**Figure 95.** Location of pilot holes.



**Figure 96.** Push block dimensions and construction.

## Using Auxiliary Fence and Push Block

1. Place auxiliary fence on table and clamp it to fence at both ends, then adjust distance between auxiliary fence and blade—this determines how wide workpiece will be ripped (see **Figure 97**).
2. Install blade guard, then secure spreader pawls in upright position, as shown in **Figure 56** on **Page 39**, so they do not interfere with push block lip.
3. Place workpiece 1" behind blade and evenly against table and auxiliary fence (see **Figure 98**).



**Figure 97.** Adjusting ripping distance between blade and auxiliary fence.

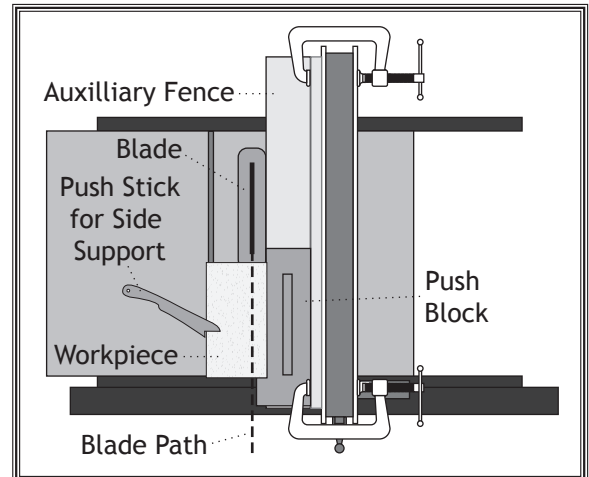
**⚠ WARNING**

**Keep blade guard installed and in down position. Failure to do this could result in serious personal injury or death.**

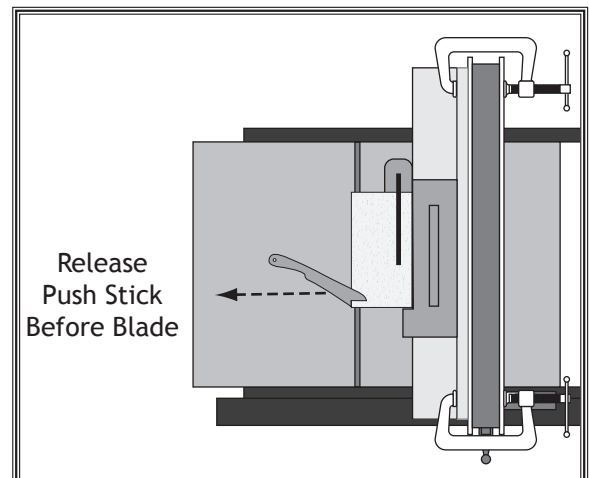
4. Turn saw **ON**, then begin ripping workpiece using a push stick for side support.
5. As workpiece nears end of cut, place push block on auxiliary fence with lip directly behind workpiece, then release push stick just before blade.
6. Guide workpiece rest of the way through cut with push block, as shown in **Figure 99**.

**⚠ WARNING**

**Turn OFF saw and allow blade to come to a complete stop before removing cut-off piece. Failure to follow this warning could result in serious personal injury.**



**Figure 98.** Push block in position to push workpiece through blade.



**Figure 99.** Ripping with push block.

## Outfeed & Support Tables

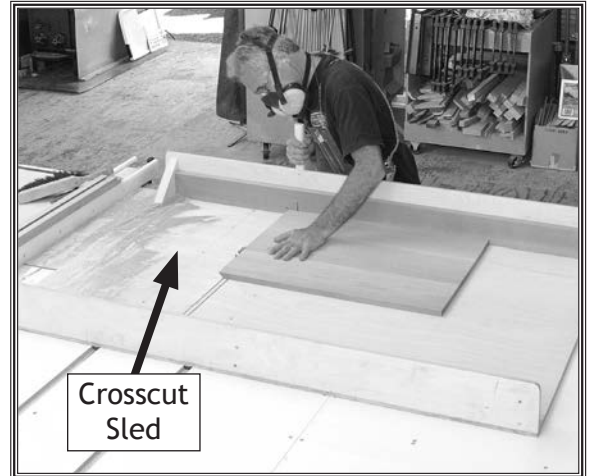
One of the best accessories for improving the safety and ease of using a table saw is simply placing a large table (outfeed table) behind the saw to catch the workpiece (see **Figure 100**). Additionally, another table to the left of the saw (support table) can also help support large workpieces so they can be cut safely and accurately.



**Figure 100.** Example of support and outfeed tables.

## Crosscut Sled

A crosscut sled (see **Figure 101**) is a fantastic way to improve the safety and accuracy of crosscutting on the table saw. Most expert table saw operators use a crosscut sled when they have to crosscut a large volume of work, because the sled offers substantial protection against kickback when crosscutting.



**Figure 101.** Example of a crosscut sled.

# ACCESSORIES

## Table Saw Accessories

The following table saw accessories may be available through your local Woodstock International Inc. Dealer. If you do not have a dealer in your area, these products are also available through online dealers. Please call or e-mail Woodstock International Inc. Customer Service to get a current listing of dealers at: 1-800-840-8420 or at [sales@woodstockint.com](mailto:sales@woodstockint.com).

### D2271—Shop Fox Heavy-Duty 9-Roller Table

Use this versatile roller table wherever you need extra workpiece support. Features all-steel welded construction and measures 19" x 65". Comes with 9 ball bearing rollers and has four independently adjustable legs for any leveling requirement. Adjustable in height from 26<sup>3</sup>/<sub>8</sub>" to 44<sup>1</sup>/<sub>8</sub>". 1,000 lb. capacity!



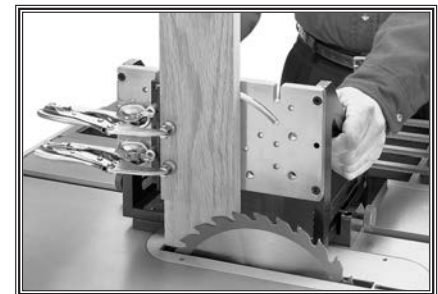
### W1727—1 HP Dust Collector

Specifications: • 1 HP, 120V/240V, single-phase motor • 800 CFM air suction capacity • 5.67" static pressure • One 4" intake hole • 9" balanced steel, radial fin impeller • 2.1 cubic feet of bag capacity • 15<sup>3</sup>/<sub>4</sub>" x 39<sup>3</sup>/<sub>4</sub>" base on casters for portability • 2.5-micron bag filtration • Power-coated finish for durability • 54<sup>1</sup>/<sub>2</sub>" height with bag inflated.



### W1500—Right Angle Jig

This jig is constructed using top quality aluminum castings and plates which are machined to exacting tolerances. It has the perfect weight-use ratio to dampen vibration, yet is still light enough to easily slide the workpiece through the machining process. Its quality and precision are evident from the first cut. Cut tenons, dadoes, rail ends, and finger joints safely and with complete accuracy.



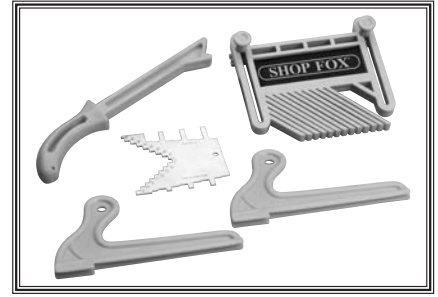
### D3246—Tenoning Jig

This jig can help you produce perfect tenons for mortise and tenon joinery. This tenoning jig also adjusts for angled tenon cutting set-ups. Standard <sup>3</sup>/<sub>8</sub>" x <sup>3</sup>/<sub>4</sub>" miter bar fits all miter gauge slots including T-slots.



**D4061—5-Pc. Safety Kit**

Comes with four table saw jigs, essential for safe operation. Includes two push blocks, push stick, featherboard, and combination saw and router gauge. Featherboard fits  $\frac{3}{8}$ " x  $\frac{3}{4}$ " miter slots.



**D3096—Featherboard**

Reduce the risk of kick-back without the use of clamps. These featherboards are designed to lock into  $\frac{3}{8}$ " and  $\frac{3}{4}$ " miter gauge slots and are adjustable for various stock widths.

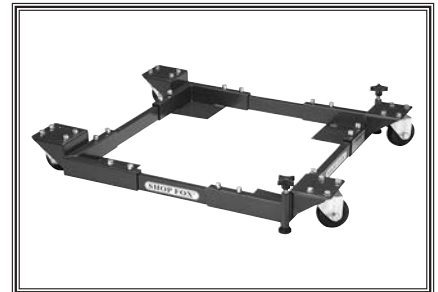


- D4206—Clear Flexible Hose 4" x 10'
- D4256—45° Elbow 4"
- W1007—Plastic Blast Gate 4"
- W1017—90° Elbow 4"
- D4216—Black Flexible Hose 4" x 10'
- W1053—Anti-Static Grounding Kit
- W1317—Wire Hose Clamp 4"

We've handpicked a selection of commonly used dust-collection components for machines with 4" dust ports.

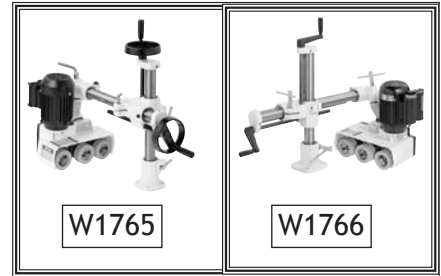


The **Model D2057 Heavy-Duty Adjustable Mobile Base** is designed to give you a stable and mobile platform upon which to mount machinery and equipment having a variety of base sizes and weights. Adjusts from 20" x 20" to 29 $\frac{1}{2}$ " x 29 $\frac{1}{2}$ ". 700 lb. maximum capacity.

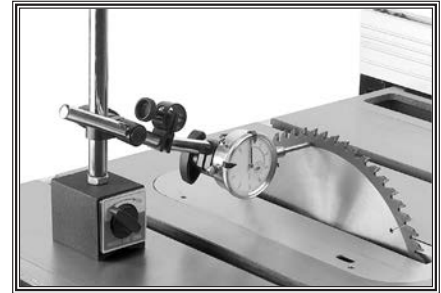


**Model W1851 (For Machines Mfd. Since 10/17)**

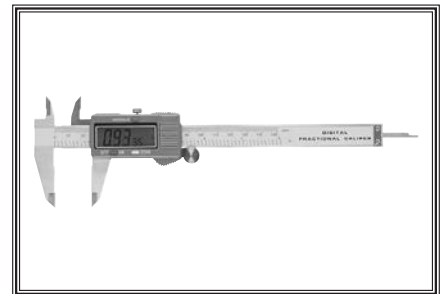
**Power Feeders** will make light work out of those big jobs with greater accuracy and safety. The **Model W1765** features a 1/4 HP, 110V, 1.8 Amp motor. The **Model W1766** features a 1/2 HP, 220V, 4 Amp motor. Both models feature forward/reverse, X/Y/Z adjustment, multiple feed speeds, and synthetic rubber wheels.



The **Model D3207 Magnetic Base with Dial Indicator in Case** is the best value in precision measuring instruments. Powerful magnetic base with infinitely adjustable control arm, fine tuning beam and magnetic switch. Add to this the 1" travel dial indicator with divisions of 0.001", 0.100" per revolution, and a 0.100" counter, and any setup job is a snap.



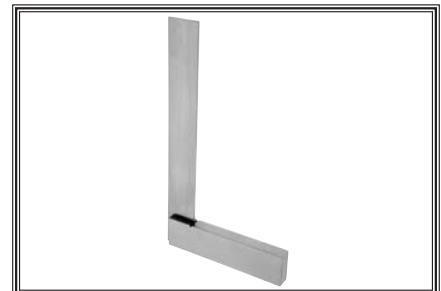
The **Model D4112 6" Fractional Digital Calipers** has a large LCD readout that converts to decimal inch, fractional inch and millimeters with the push of a button. Measure internal, external dimensions, depth, steps and differential measurements. Features thumb roll and stainless steel construction. Range: 0-6", 0-150mm. Resolution: 0.0005", 0.01mm, 1/128".



High-precision **Aluminum Squares** are perfect for square layouts and machine setup.

**D3383:** 4" Precision Square

**D3384:** 6" Precision Square



# MAINTENANCE

## General

For optimum performance from your machine, follow this maintenance schedule and refer to any specific instructions given in this section.

### Daily Check:

- Inspect blades for damage or wear.
- Check for loose mounting bolts/arbor nut.
- Check cords, plugs, and switch for damage.
- Check for the proper function of the blade guard (see **Blade Guard Assembly** on **Page 37**).
- Check for any other condition that could hamper the safe operation of this machine.
- Wipe the table clean after every use—this ensures moisture from wood dust does not remain on bare metal surfaces.

### Weekly Maintenance:

- Wipe down the table surface and grooves with a lubricant and rust preventive such as SLIPIT®.
- Vacuum dust buildup from the motor housing and trunnions.
- Clean the pitch and resin from the saw blade with a cleaner like OxiSolv® Blade & Bit Cleaner.

### Monthly Maintenance:

- Check/tighten the belt tension (**Page 80**).

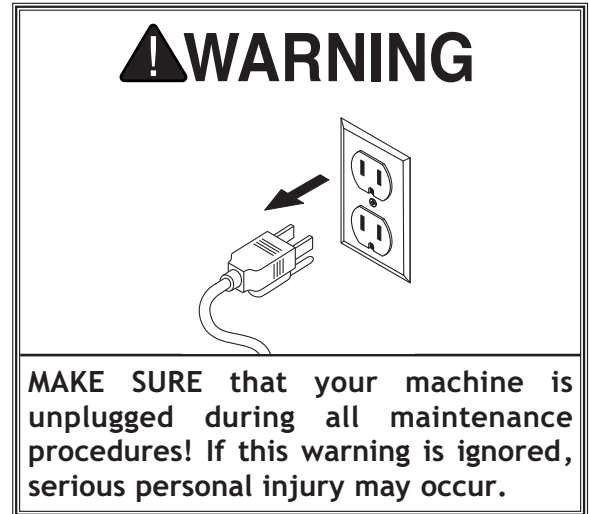
### Every 6-12 Months:

- Lubricate trunnion slides (**Page 67**).
- Lubricate worm gear and bull gear (**Page 67**).
- Lubricate leadscrew (**Page 67**).

## Cleaning & Protecting

Cleaning the Model W1851 is relatively easy. Vacuum excess wood chips and sawdust, and wipe off the remaining dust with a dry cloth. If any resin has built up, use a resin-dissolving cleaner to remove it.

Protect the unpainted cast-iron table by wiping it clean after every use—this ensures moisture from wood dust does not remain on bare metal surfaces. Keep your table rust-free with regular applications of quality lubricants.



# Lubrication

It is essential to clean components before lubricating them because dust and chips build up on lubricated components and make them hard to move. Simply adding more grease to them will not yield smooth moving components.

Clean the components in this section with an oil/grease solvent cleaner and shop rags.

If you thoroughly clean the components in this section before lubricating them, the result will be silky smooth movement when turning the handwheels, which will result in much higher enjoyment on your part!

The following are the main components that need to be lubricated:

- Trunnion Slides
- Worm Gear, Bull Gear, and Leadscrew

## Trunnion Slides

Lubrication Type .....T26419 or NLGI#2 Equivalent  
 Amount ..... 1-2 Dabs  
 Lubrication Frequency ..... 6-12 Months

Clean out the front and rear trunnion slides with mineral spirits and a rag, then apply grease into each groove. Move the blade tilt back and forth to spread the grease (see Figure 102).

## Worm Gear, Bull Gear, Leadscrew

Lubrication Type .....T26419 or NLGI#2 Equivalent  
 Amount ..... Dab  
 Lubrication Frequency ..... 6-12 Months

Clean away any built up grime and debris from the worm gear, bull gear, and leadscrew (see Figures 103-104) with a wire brush, rags, and mineral spirits. Allow the components to dry, then apply a thin coat of grease to them.

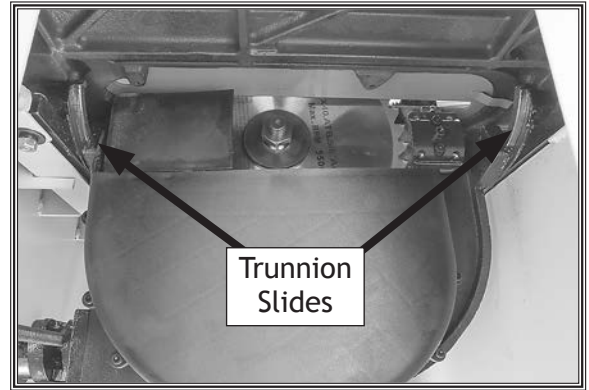


Figure 102. Trunnion slide locations.

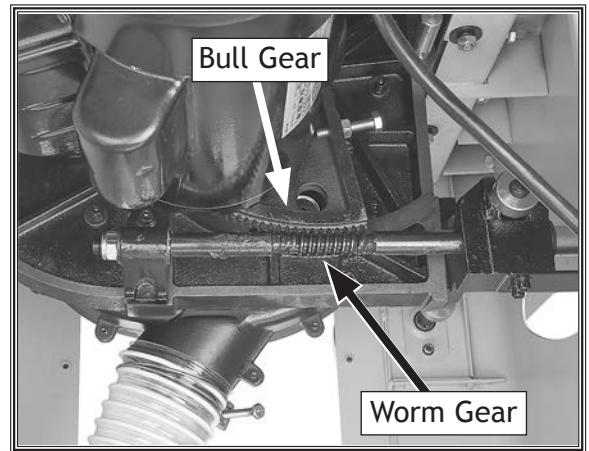


Figure 103. Worm and bull gear location.

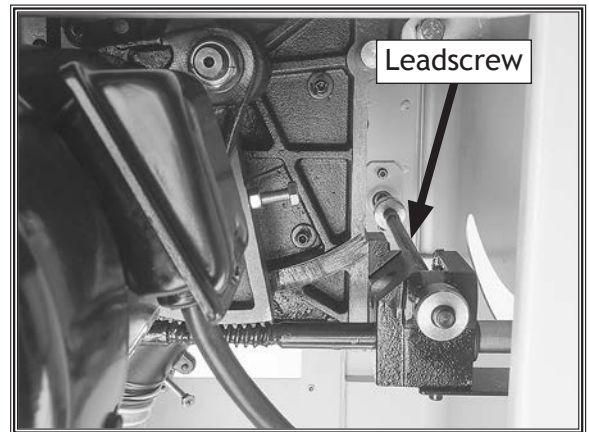


Figure 104. Leadscrew location.

# SERVICE

## General

This section covers the most common service adjustments or procedures that may need to be made during the life of your machine.

If you require additional machine service not included in this section, please contact Woodstock International Technical Support at (360) 734-3482 or send e-mail to: [techsupport@woodstockint.com](mailto:techsupport@woodstockint.com).

## Blade Tilt Stops

The table saw features stop collars that stop the blade exactly at 45° and 90° when tilting it with the handwheel. The stops have been set at the factory and should require no adjustments, unless you notice that your cuts are not accurate.

**Note:** The tilt scale reads "0" when the blade is 90° to the table.

| Tools Needed          | Qty |
|-----------------------|-----|
| 90° Square .....      | 1   |
| 45° Square .....      | 1   |
| Hex Wrench 2.5mm..... | 1   |
| Hex Wrench 3mm .....  | 1   |

### Setting 90° Stop Collar

1. DISCONNECT MACHINE FROM POWER!
2. Raise blade as high as it will go, then tilt it toward 0° until it stops and cannot be tilted any more.
3. Place 90° square against table and blade so it contacts blade evenly from bottom to top, as shown in **Figure 105**. Make sure blade tooth does not obstruct placement of square.
  - If blade is 90° to table, then adjustments do not need to be made. Make sure tilt indicator arrow shown in **Figure 106** points to 0° mark on scale. Adjust position by loosening button head screw, moving indicator with your fingers, then tightening screw.
  - If blade is *not* 90° to table, you will need to adjust 90° stop collar. Proceed to next step.

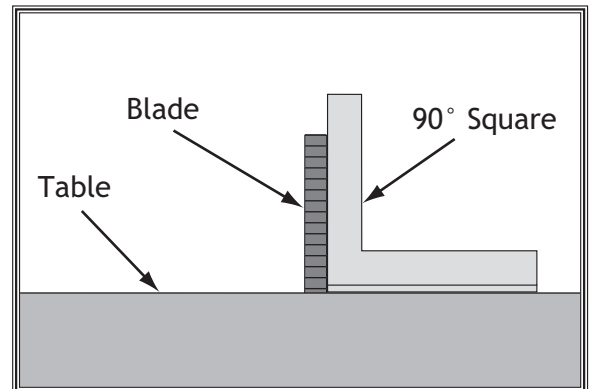
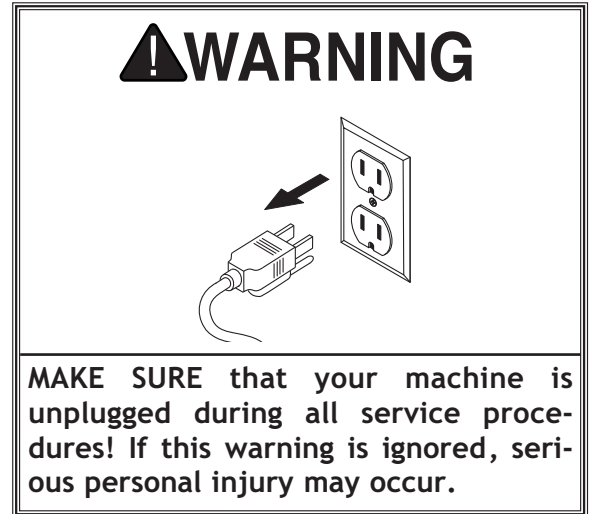
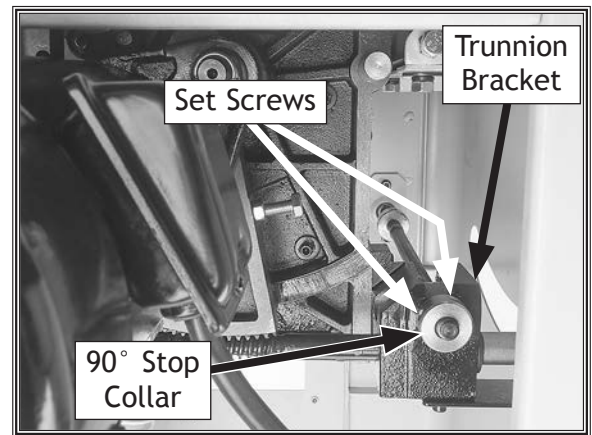


Figure 105. Checking blade at 90°.



Figure 106. Tilt indicator arrow.

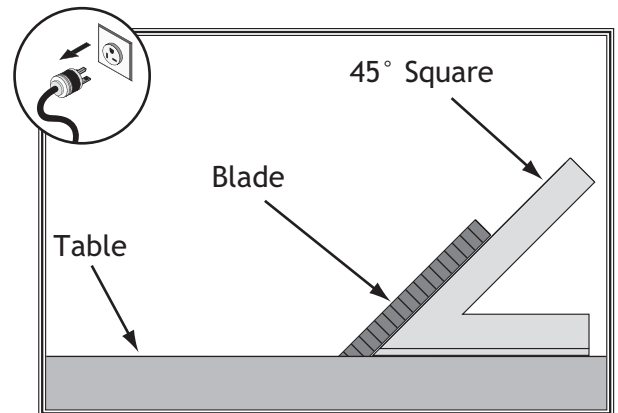
4. Tilt blade away from 0° by about 5°, so there is room for 90° stop collar to move.
5. Open motor door, loosen set screws shown in **Figure 107**, then thread 90° stop collar one turn away from trunnion bracket. This will allow you to square blade in next step.
6. Place square against blade, as shown in **Figure 105** on **Page 68**, then adjust blade until it is perfectly square to table.
7. Without turning blade tilt leadscrew, finger-tighten 90° collar against trunnion bracket, then tighten two set screws to secure collar position.
8. Repeat **Steps 2-3** to verify that collar adjustment you made was correct. When adjustment is satisfactory, close motor door.



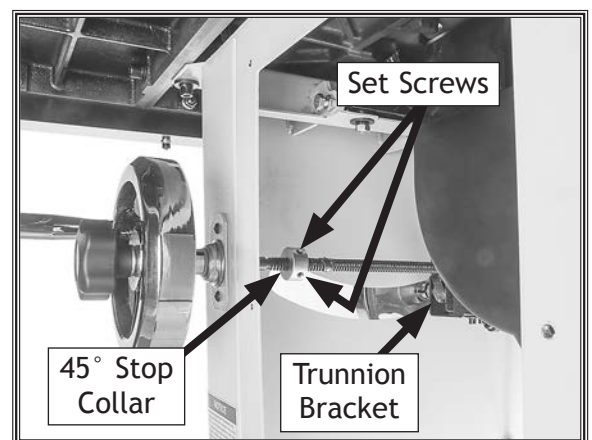
**Figure 107.** 90° stop collar and set screws.

### Setting 45° Stop Collar

1. DISCONNECT MACHINE FROM POWER!
2. Raise blade as high as it will go, then tilt it towards 45° until it stops and cannot be tilted any more.
3. Place a 45° square against table and blade so it contacts blade evenly from bottom to top, as shown in **Figure 108**. Make sure a blade tooth does not obstruct placement of square.
  - If blade is 45° to table, then adjustments do not need to be made.
  - If blade is *not* 45° to table, you will need to adjust 45° stop collar. Proceed to next step.
4. Tilt blade to 30°, so there is room for stop collar to move.
5. Open right access cover, loosen set screws on 45° stop collar (see **Figure 109**), then turn collar one turn away from trunnion bracket. This will allow you to adjust blade to exactly 45° in next step.
6. Place a 45° square against blade, as shown in **Figure 108**, then adjust blade until it is exactly 45° to table.
7. Without turning blade tilt leadscrew, finger-tighten 45° stop collar against trunnion bracket, then tighten two set screws to secure collar position.



**Figure 108.** Checking blade at 45°.



**Figure 109.** Location of 45° stop collar (right access cover removed).

8. Repeat **Steps 2-3** to verify that collar adjustment you made was correct. When adjustment is satisfactory, close right access cover.

**SERVICE**

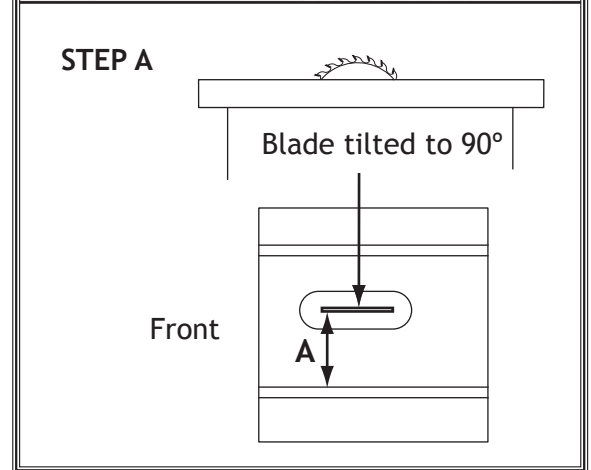
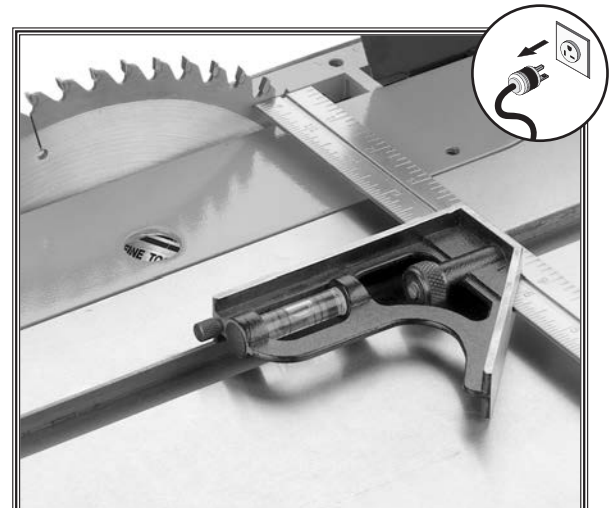
# Miter Slot to Blade Parallelism

Your table saw will give the best results if the miter slot and the rip fence are adjusted parallel to the blade. If either of these are not exactly parallel, your cuts and your finished work will be lower in quality, but more importantly, the risk of kickback will be increased.

| Tools Needed            | Qty       |
|-------------------------|-----------|
| Adjustable Square ..... | 1         |
| Marker .....            | 1         |
| Metal Shim Stock.....   | As Needed |
| Hex Wrench 6mm .....    | 1         |

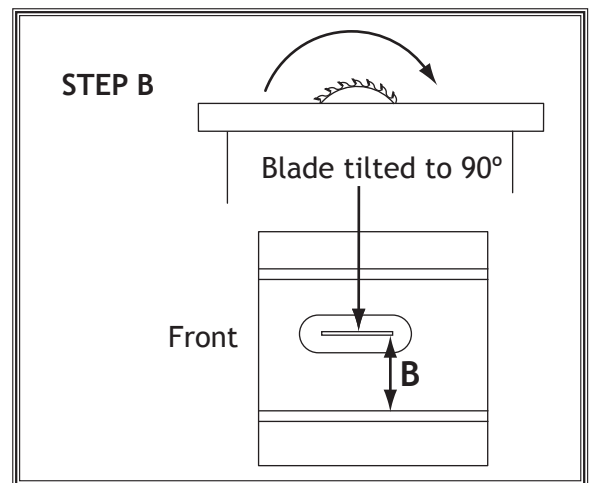
To adjust blade parallel to miter slot, do these steps:

1. DISCONNECT MACHINE FROM POWER!
2. Tilt blade to 0°, then use an adjustable square to measure distance from miter slot to a carbide tip on blade, as shown in **Figure 110**. Make sure that face of adjustable square is even along miter slot.
3. With end of adjustable square just touching tip, lock square in place. Now, mark carbide tip with a marker where you made this measurement.
4. Rotate marked blade tip to other end of table insert.



**Figure 110.** Making first slot-to-blade measurement at 90°.

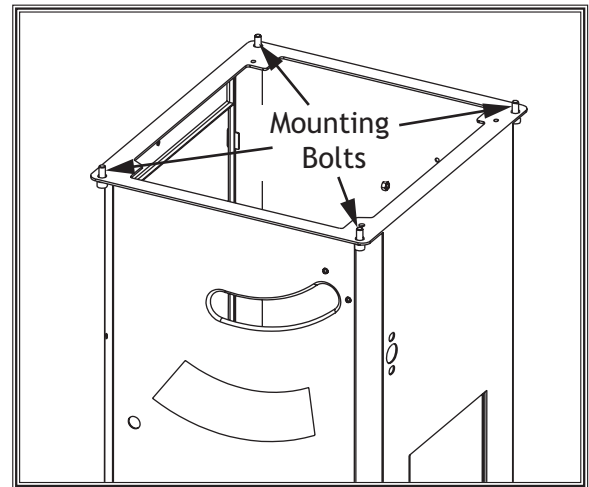
5. Slide adjustable square down to other end of table insert and compare distance from marked blade tip to end of adjustable square, as shown in **Figure 111**.
  - If blade tip measurement *is* same on both sides, go to **Step 8**.
  - If blade tip *does not* touch end of adjustable square similar to first measurement, table will need to be adjusted. Proceed to **Step 6**.



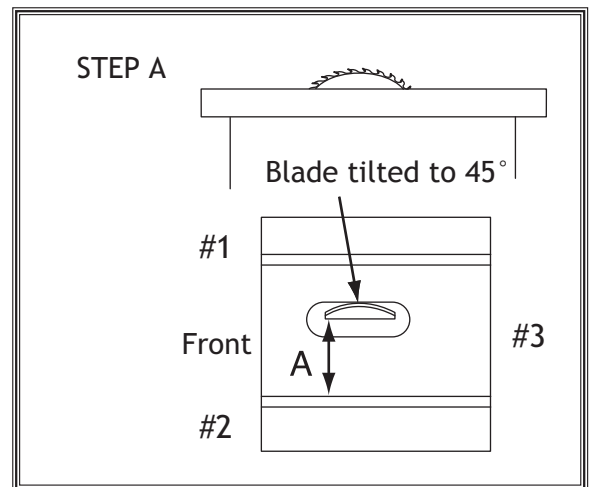
**Figure 111.** Making second slot-to-blade measurement at 90°.

6. Loosen (4) table mounting bolts securing table top to base (see **Figure 112**), and lightly tap table in direction needed to square table to blade.
7. Repeat **Steps 2-6** until blade and miter slot are parallel, then retighten table mounting bolts.
8. Tilt blade to 45° and recheck miter slot-to-blade parallelism.
  - If blade is still parallel with miter slot, no additional adjustments need to be made.
  - If blade was parallel with miter slot at 0° but not at 45°, one end of table will need to be shimmed higher with metal shim stock. Continue to **Step 9**.
9. Loosen (4) table mounting bolts from **Step 6**.
10. Refer to **Figures 113-114** for shim placement. If distance A is shorter than B, shim(s) will need to be placed under corners #1 and #2. If the distance of B is shorter than A, shim(s) will need to be placed under corner #3. Very thin shim stock works well.
11. Tighten one table mounting bolt a small amount and then repeat with the others, tightening each down the same amount. Continue this process with all the bolts, tightening them a little each time until they are all secure.
12. Now recheck blade to miter slot at 0° and 45° by repeating **Steps 2-5**.
  - If distance of A and B are equal, continue to **Step 13**.
  - If distances *are not* equal, repeat **Steps 9-12**.
13. Once miter slot is adjusted to blade, recheck all measurements and be sure table mounting bolts are secure.

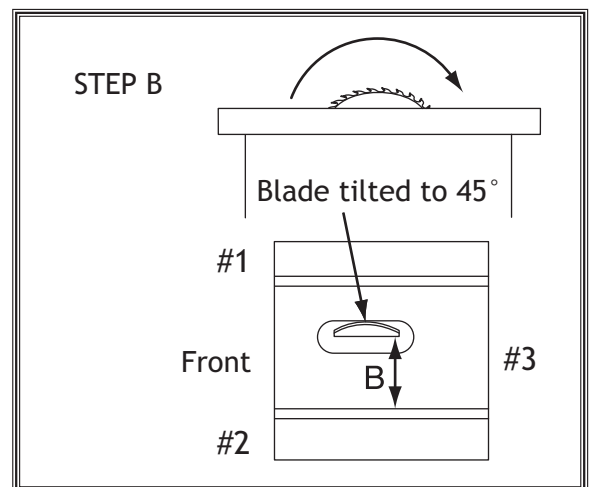
**Note:** If you remove the table in the future, note the shim placements and reassemble them exactly how they came apart.



**Figure 112.** Location of table mounting bolts (table omitted for clarity).



**Figure 113.** Shim procedure diagram A.



**Figure 114.** Shim procedure diagram B.

# Spreader or Riving Knife Alignment

## Checking Alignment

The blade guard spreader/riving knife must be aligned with the blade when installed. If the spreader/riving knife is not aligned with the blade, then the workpiece will be forced sideways during the cut, which will increase the risk of kickback.

| Tools Needed                  | Qty |
|-------------------------------|-----|
| Straightedge (min. 12") ..... | 1   |

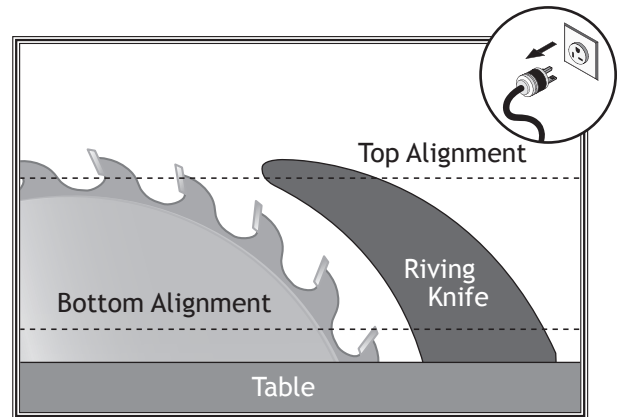
To check spreader/riving knife alignment, do these steps:

1. DISCONNECT MACHINE FROM POWER!
2. Raise saw blade to maximum height so you have easy working access.
3. Place straightedge against side of blade and spreader/riving knife at top and bottom, as shown in **Figure 115**. Spreader/riving knife should be parallel with blade along its length at both positions, and in "Alignment Zone," as shown in **Figure 116**.

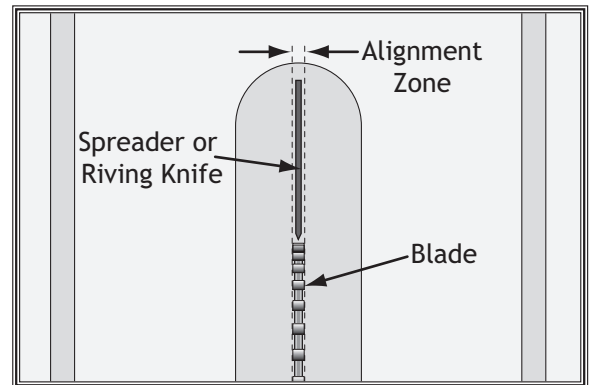
- If spreader *is* in alignment zone no adjustments need to be made.
- If spreader/riving knife *is not* parallel with blade and inside alignment zone, then it needs to be adjusted. Proceed to **Adjusting Alignment** instructions.
- If spreader/riving knife *is not* parallel with the blade at either the top or bottom, it may be bent.

4. Remove spreader/riving knife and place it on flat surface and check to see if spreader/riving knife lays evenly along its length.

- If spreader/riving knife does not lay evenly, proceed to **Adjusting Bent Spreader/Riving Knife** on **Page 73**.



**Figure 115.** Example of checking top and bottom riving knife parallelism with blade.



**Figure 116.** Spreader/riving knife alignment zone.

## Adjusting Alignment

The spreader/riving knife mounting position can be adjusted into alignment with the blade using the set screws on the spreader/riving knife mounting block.

|                       |            |
|-----------------------|------------|
| <b>Tool Needed</b>    | <b>Qty</b> |
| Hex Wrench 2.5mm..... | 1          |

To adjust spreader/riving knife position, do these steps:

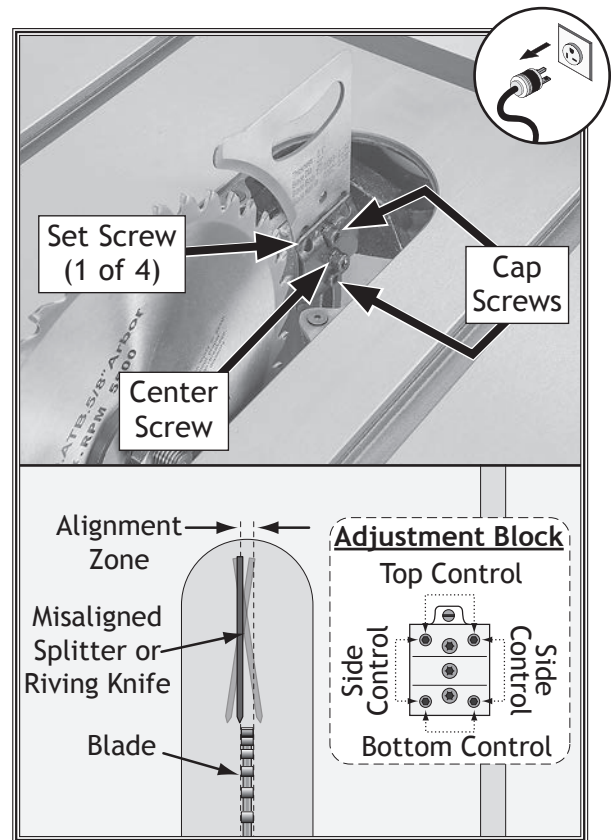
1. DISCONNECT MACHINE FROM POWER!
2. Remove table insert.
3. Loosen (2) cap screws on mounting block, then adjust either top or bottom control set screws or side control set screws (see **Figure 117**) to move it the needed direction.

**Top and Bottom Control:** To move the top of the spreader/riving knife right or left (and the bottom of the spreader/riving knife in the opposite direction), adjust the top and bottom pair of set screws on the mounting block an equal amount in the opposite direction.

**Side Control:** To move the front of the spreader/riving knife left or right (and the rear of the spreader/riving knife in the opposite direction), adjust each pair of side control set screws an equal amount in the opposite direction.

**Note:** To adjust how tightly the mounting block holds the spreader/riving knife, adjust the center screw.

4. Re-install table insert.
5. Follow **Checking Alignment, Steps 1-3**.
  - If spreader/riving knife is in alignment zone, no additional steps are necessary.
  - If spreader/riving knife is still *not* in alignment zone, continue adjusting set screws on mounting block as necessary to correctly position spreader/riving knife.
6. Tighten (2) cap screws on mounting block to secure spreader/riving knife adjustment.



**Figure 117.** Set screws for adjusting spreader/riving knife position.

## Adjusting Bent Spreader/Riving Knife

1. DISCONNECT MACHINE FROM POWER!
2. Bend spreader or riving knife by hand while installed, then follow **Steps 1-3** in **Checking Alignment** on **Page 72** to determine if it is parallel with blade and inside "Alignment Zone" (refer to **Figure 115** **Checking Alignment** on **Page 72**).
  - If this doesn't work, remove it to straighten.
  - If you cannot straighten it properly, replace it.

# Fence Adjustments

There are four main adjustments for the fence: height off the table, squareness, parallelism with the miter slot, and clamping pressure. These adjustments are interconnected and some repetition may be needed when adjusting.

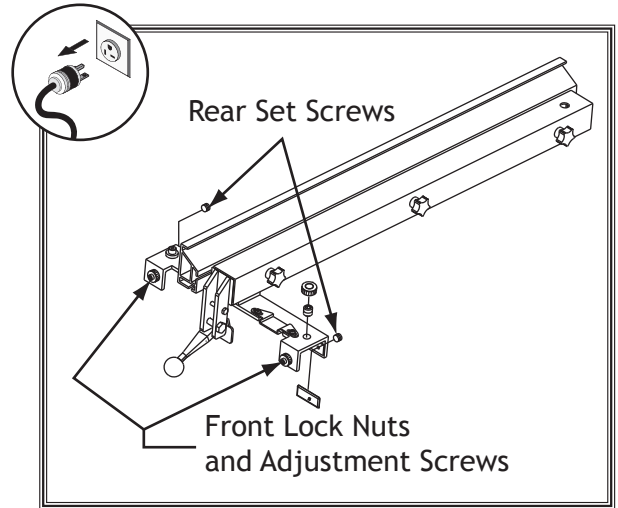
| Tools Needed             | Qty |
|--------------------------|-----|
| Hex Wrench 6mm .....     | 1   |
| Square .....             | 1   |
| Felt-Tipped Marker ..... | 1   |

## Height and Square

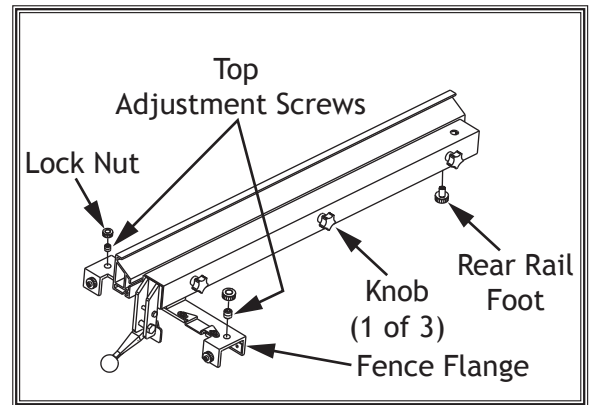
The fence should be adjusted high enough off the table so that it does not drag across the surface or allow wood chips to get caught between the fence and table. Also, the fence face must be square to the table in order to produce accurate cuts.

To check/adjust fence height and squareness to table, do these steps:

1. DISCONNECT MACHINE FROM POWER!
2. Remove fence from saw and place it on a flat surface.
3. Unscrew front lock nuts and adjustment screws shown in **Figure 118** until they are barely threaded into fence flange.
4. Back out rear set screws until they are just threaded into fence flange (see **Figure 118**).
5. Install fence onto table, then loosen fence knobs (see **Figure 119**), pull fence up from center, and tighten each knob.
6. Loosen top lock nuts on fence flange and lock nut on rear rail foot, shown in **Figure 119**.
7. Turn top adjustment screws and rear foot screw so there is approximately  $\frac{1}{16}$ " clearance between bottom of fence and table, front-to-back and side-to-side, then tighten lock nuts.

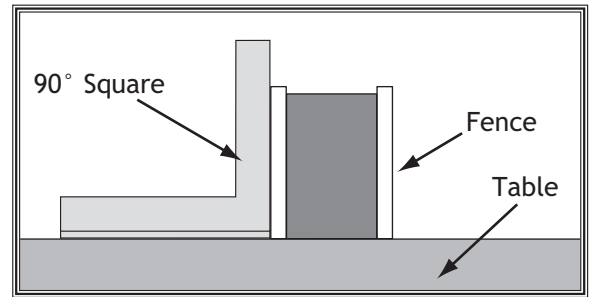


**Figure 118.** Location of screws used to adjust fence parallelism and clamping pressure.



**Figure 119.** Fence components used to adjust fence height and squareness to table.

8. Place square on table and against face of fence, as shown in **Figure 120**, to check if fence is square to table.
  - If fence *is* square to table, proceed to **Parallelism & Clamping Pressure**.
  - If fence *is not* square to the table, proceed to **Step 9**.
9. Loosen top lock nuts and adjust top screws (see **Figure 119**) on **Page 74** to make fence face 90° to table, then tighten lock nuts.



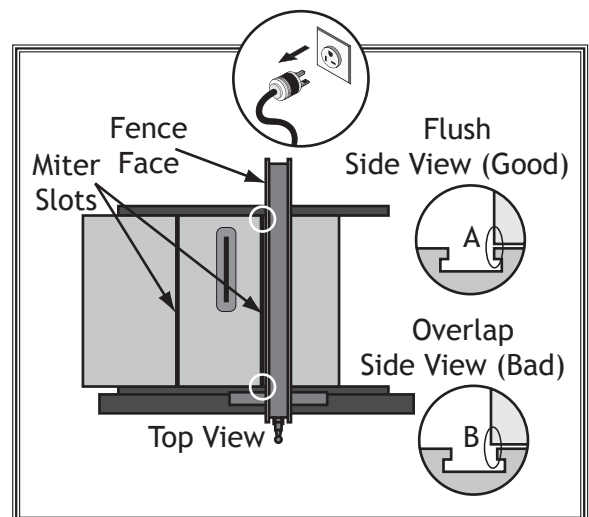
**Figure 120.** Checking if fence is square to table.

### Parallelism & Clamping Pressure

Set screws on the rear side of the fence flange position the fence parallel to the blade and adjust the clamping pressure to hold fence securely. Before starting this procedure, make sure the blade is parallel with the miter slot.

To adjust fence parallelism and clamping pressure, do these steps:

1. DISCONNECT MACHINE FROM POWER!
2. Lock fence, tap front side with your fist, and check to see if it moved sideways over table.
  - If fence did *not* move, proceed to **Step 5**.
  - If fence moved, remove it from table and proceed to **Step 3**.
3. Turn each rear set screw (see **Figure 118** on **Page 74**) in  $\frac{1}{6}$ th of a turn.
4. Re-install fence and repeat **Step 2**.
5. Slide fence up against right-hand edge of miter slot, as shown in **Figure 121**, and lock it in place.
6. Examine how fence lines up with miter slot along its length.
  - If fence and miter slot are flush from front to rear, as shown in **Figure 121A**, proceed to **Step 8**.
  - If rear of fence overlaps miter slot, as shown in **Figure 121B**, fence is misaligned. Proceed to **Step 7**.



**Figure 121.** Example of aligning fence to miter slot.

7. Remove fence, then alternately loosen and tighten rear fence set screws in equal amounts to adjust rear of fence until it is parallel with miter slot.
8. Loosen both front lock nuts (see **Figure 118** on **Page 74**). Tighten adjustment screws so they just touch fence tube, back off screws  $\frac{1}{2}$  turn, then tighten lock nuts.

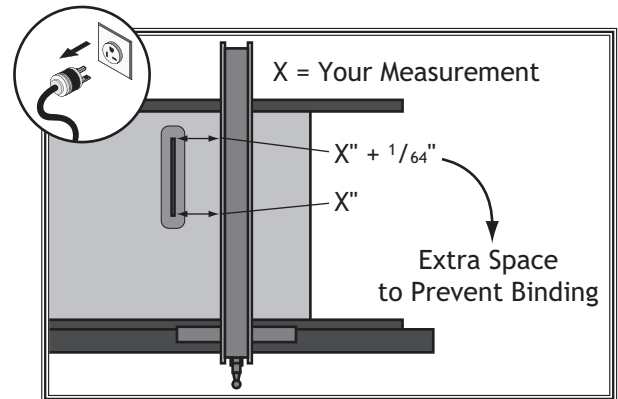
### Optional Offset Fence Adjustment

Some woodworkers prefer to offset the rear of the fence  $\frac{1}{64}$ " from the blade, as shown in **Figure 122**, to help prevent the workpiece from binding and burning.

The argument is that this offset adjustment reduces the chance of kickback by alleviating potential binding that may occur between the backside of the blade and fence. The tradeoff is slightly less accurate cuts.

To offset fence, do these steps:

1. DISCONNECT MACHINE FROM POWER!
2. With a felt tip pen, mark one saw tooth and rotate blade so this tooth is positioned at back of table insert.
3. Place fence on table, and clamp fence to table.
4. Measure distance between tooth and fence face, as shown in **Figure 122**.
5. Remove fence, and adjust rear set screws as previously discussed to achieve an offset of  $\frac{1}{64}$ " between marked tooth and fence face.
6. Re-install fence and measure distance again between marked tooth and fence face. The rear measurement should be  $\frac{1}{64}$ " greater than previously measured in **Step 4**.



**Figure 122.** Adjusting fence with a  $\frac{1}{64}$ " offset.

# Fence Scale Calibration

The fence scale indicator window, shown in **Figure 123**, can be calibrated with the fence scale if you notice that your cuts do not accurately match what is shown on the fence scale.

The indicator adjusts by loosening the two mounting screws and sliding it in the desired direction.

| Tools Needed             | Qty |
|--------------------------|-----|
| Hex Wrench 3mm .....     | 1   |
| Scrap Piece of Wood..... | 1   |
| Tape Measure .....       | 1   |

To calibrate fence scale indicator windows, do these steps:

1. Position and lock fence at 13", as indicated by scale, then cut your scrap piece of wood.
2. Reposition and lock fence at 12", as indicated by scale.
3. Flip your scrap piece of wood over, placing side that was cut in **Step 2** against fence, and cut your scrap piece of wood.
4. Measure width of freshly cut workpiece with tape measure. Workpiece width should be exactly 12". If it is not, then adjust indicator window to match width of workpiece.

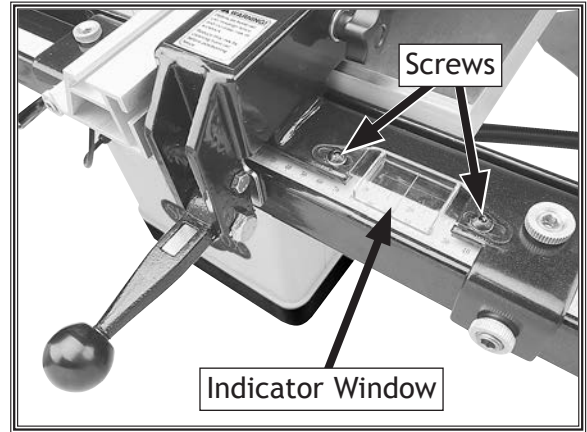


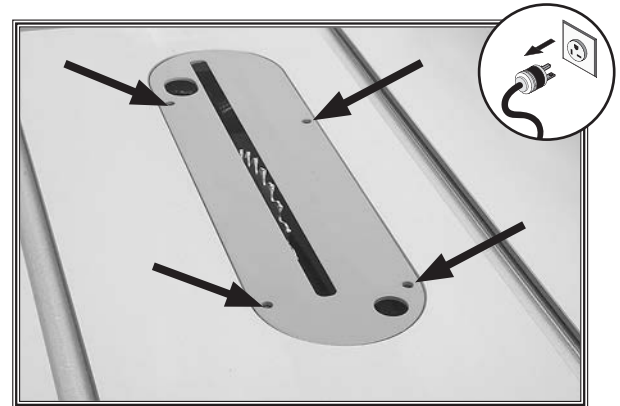
Figure 123. Fence indicator window.

# Table/Dado Insert Adjustment

The table/dado insert must sit perfectly flush with the table to provide a smooth, continuous surface for the workpiece to slide over. The insert is held in place by a magnet and sits on top of four adjustment screws (see **Figure 124**).

The insert should be checked and adjusted any time it is removed and replaced, after prolonged use, or any time you notice the workpiece or fence does not slide smoothly over the insert.

| Tools Needed         | Qty |
|----------------------|-----|
| Hex Wrench 3mm ..... | 1   |
| Straight Edge .....  | 1   |



**Figure 124.** Location of table/dado insert holes with adjustment screws.

To check and adjust insert, do these steps:

1. DISCONNECT MACHINE FROM POWER!
2. Place straightedge across insert and check to make sure insert is flush with table at front and back of throat.
  - If insert *is* flush with table, no adjustments are necessary.
  - If insert *is not* flush with table, proceed to **Step 3**.
3. Insert hex wrench through holes shown in **Figure 124** and either loosen screws to raise insert, or tighten screws to lower it. Repeat **Steps 2-3** until insert is perfectly flush with surface of table.

**Note:** Table insert should be firmly installed (should not rock) in the table. Each screw should support insert evenly.

# Miter Gauge Adjustments

The miter gauge can be adjusted so it is perpendicular to the blade and snug in the T-slot.

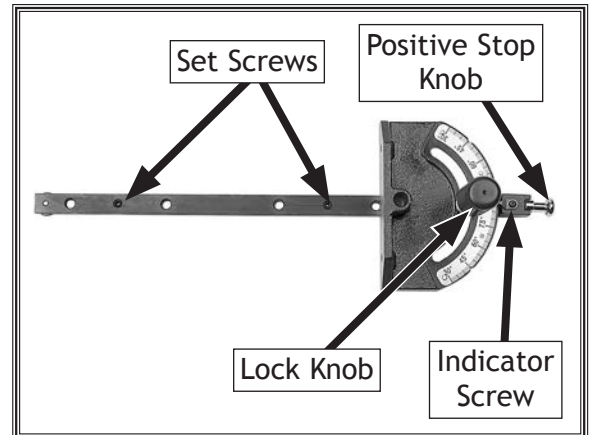
| Tools Needed          | Qty |
|-----------------------|-----|
| 90° Square .....      | 1   |
| 45° Square .....      | 1   |
| Hex Wrench 2mm .....  | 1   |
| Hex Wrench 2.5mm..... | 1   |
| Hex Wrench 4mm .....  | 1   |

## Checking/Setting 90° Stops

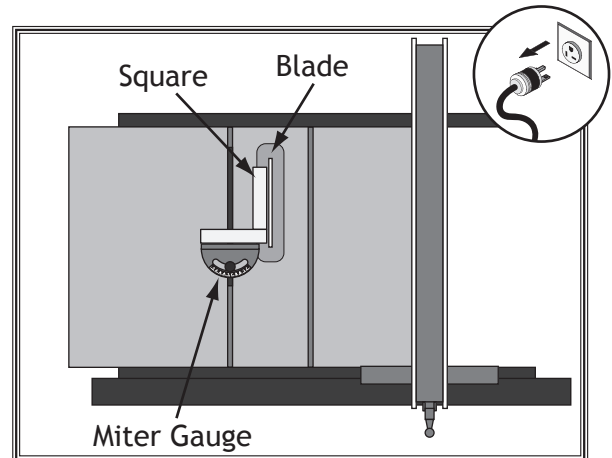
1. DISCONNECT MACHINE FROM POWER!
2. Slide miter gauge into T-slot on table.
3. Loosen miter gauge lock knob, pull out positive stop knob, then pivot miter gauge body to 90° so stop knob springs into position (see **Figure 125**).
4. Place square evenly against face of miter gauge and blade, as shown in **Figure 126**.
  - If square touches miter body and body of blade (not the teeth) evenly at same time, then it is square to blade and 90° stop is set correctly. No further adjustments are necessary.
  - If square *does not* touch miter body and blade body evenly at same time, then proceed to **Step 5**.
5. Loosen button head cap screws on positive stop knob block (see **Figure 127**), adjust miter body until it is flush with square, then tighten screws.
6. Loosen indicator screw on top of miter bar, adjust pointer to 0°, then tighten screw.

## Adjusting Miter Bar Tightness

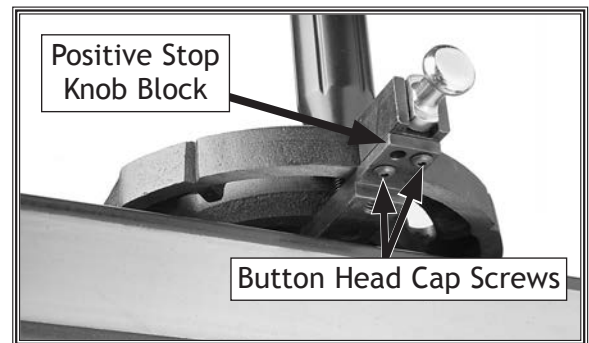
The miter bar can be adjusted so it fits more tightly in the miter slot. To adjust the miter bar tightness, adjust the set screws shown in **Figure 125** as needed. Bar should slide with little resistance.



**Figure 125.** Set screws for adjusting miter bar in miter slot.



**Figure 126.** Checking 90° stop on miter gauge.



**Figure 127.** Screws for adjusting miter body.

# Belt Tension & Replacement

The drive belt stretches slightly as the saw is used. Most of the belt stretching will happen during the first 16 hours of use, but it may continue through continued use. If you notice that the belt is slipping, it will need to be tensioned. If the belt is cracked, frayed, or shows other signs of excessive wear, it will need to be replaced.

| Tool Needed          | Qty |
|----------------------|-----|
| Hex Wrench 6mm ..... | 1   |

## Tensioning Belt

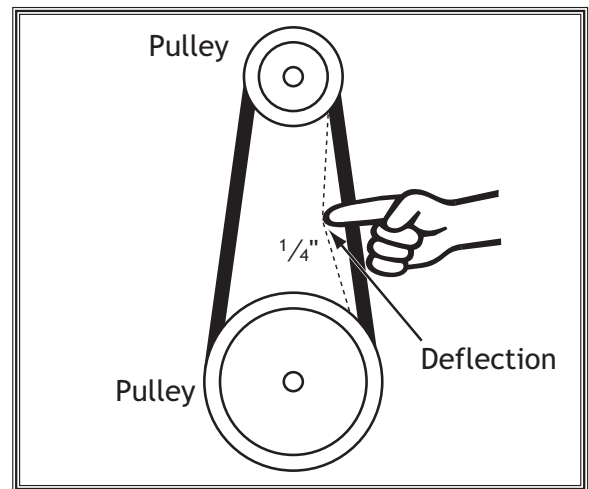
1. DISCONNECT MACHINE FROM POWER!
2. Raise blade completely, then open the motor door.
3. Loosen cap screw on motor (see **Figure 128**), and pivot motor up and down to verify it is movable.
4. Press down on motor with one hand to keep belt tension tight, then tighten cap screw.
5. Press belt in center to check belt tension. The belt is correctly tensioned when there is approximately 1/4" deflection when it is pushed with moderate pressure, as shown in **Figure 129**.
  - If there is more than 1/4" deflection, loosen cap screw, push motor down, then tighten cap screw.
6. Close motor door.



**Figure 128.** Location of cap screw for adjusting belt tension.

## Replacing Belt

1. DISCONNECT MACHINE FROM POWER!
2. Raise blade completely, then open motor door.
3. Loosen cap screw shown in **Figure 128** and lift motor fully to remove tension on belt. Tighten cap screw, then roll belt off arbor and motor pulleys.
4. Install new belt, loosen cap screw, then lower motor.
5. Press down on motor with one hand to keep belt tension tight and tighten cap screw.
6. Follow **Step 5** in the **Tensioning Belt** subsection on this page to check V-belt tension.
7. Close motor door.



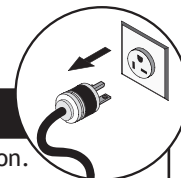
**Figure 129.** Checking belt tension.

# Troubleshooting

The following troubleshooting tables cover common problems that may occur with this machine. If you need replacement parts or additional troubleshooting help, contact our Technical Support.

**Note:** Before contacting Tech Support, find the machine serial number and manufacture date, and if available, your original purchase receipt. This information is required to properly assist you.

## Motor & Electrical



| PROBLEM  | POSSIBLE CAUSE   | CORRECTIVE ACTION  |
|--|--|--|
| Machine does not start, or power supply breaker immediately trips after startup. | <ol style="list-style-type: none"> <li>1. Locking pin installed in switch.</li> <li>2. Machine circuit breaker tripped.</li> <li>3. Power supply circuit breaker tripped or fuse blown.</li> <li>4. Plug/receptacle at fault/wired incorrectly.</li> <li>5. Motor wires connected incorrectly.</li> <li>6. Wiring open/has high resistance.</li> <li>7. START/STOP switch or circuit breaker at fault.</li> <li>8. Start capacitor at fault.</li> <li>9. Motor at fault.</li> </ol>  | <ol style="list-style-type: none"> <li>1. Remove locking pin from START button.</li> <li>2. Reset circuit breaker on switch.</li> <li>3. Ensure circuit is sized correctly and free of shorts. Reset circuit breaker or replace fuse.</li> <li>4. Test for good contacts; correct wiring.</li> <li>5. Correct motor wiring connections (Page 85).</li> <li>6. Check/fix broken, disconnected, or corroded wires.</li> <li>7. Replace switch/circuit breaker.</li> <li>8. Test/replace if faulty.</li> <li>9. Test/repair/replace.</li> </ol>   |
| Machine stalls or is underpowered.   | <ol style="list-style-type: none"> <li>1. Feed rate/cutting speed too fast.</li> <li>2. Workpiece material unsuitable for machine.</li> <li>3. Motor overheated; tripping machine circuit breaker.</li> <li>4. Blade dull or incorrect for type of cut.</li> <li>5. Belt(s) slipping.</li> <li>6. Motor wired incorrectly.</li> <li>7. Pulleys slipping on shaft or misaligned.</li> <li>8. Run capacitor at fault.</li> <li>9. Motor bearings at fault.</li> <li>10. Contactor not energized/has poor contacts.</li> <li>11. Centrifugal switch at fault.</li> <li>12. Motor at fault.</li> </ol> | <ol style="list-style-type: none"> <li>1. Decrease feed rate/cutting speed.</li> <li>2. Only cut wood/ensure moisture is below 20%.</li> <li>3. Clean motor/let cool, and reduce workload. Reset breaker.</li> <li>4. Use correct, sharp blade; reduce feed rate.</li> <li>5. Tension/replace belt(s) (Page 80).</li> <li>6. Wire motor correctly (Page 85).</li> <li>7. Tighten/replace loose pulley (Page 80); ensure pulleys are aligned.</li> <li>8. Test/repair/replace.</li> <li>9. Test/repair/replace.</li> <li>10. Test all legs for power/replace if faulty.</li> <li>11. Adjust/replace centrifugal switch if available.</li> <li>12. Test/repair/replace.</li> </ol> |
| Machine has vibration or noisy operation.  | <ol style="list-style-type: none"> <li>1. Motor or component loose.</li> <li>2. Blade at fault.</li> <li>3. Belt(s)/pulley(s) worn, loose, or misaligned.</li> <li>4. Motor mount loose/broken.</li> <li>5. Machine incorrectly mounted/resting on floor.</li> <li>6. Arbor pulley loose.</li> <li>7. Motor fan rubbing on fan cover.</li> <li>8. Arbor bearings at fault.</li> <li>9. Motor bearings at fault.</li> </ol>   | <ol style="list-style-type: none"> <li>1. Inspect/replace damaged bolts/nuts, and re-tighten with thread-locking fluid.</li> <li>2. Replace warped/bent blade; sharpen dull blade.</li> <li>3. Inspect/replace belts with new matched set. Re-align/replace shaft, pulley, set screw, and key (Page 80).</li> <li>4. Tighten/replace.</li> <li>5. Tighten mounting bolts; relocate/shim machine.</li> <li>6. Retighten/replace arbor pulley.</li> <li>7. Fix/replace fan cover; replace loose/damaged fan.</li> <li>8. Replace arbor housing bearings; replace arbor.</li> <li>9. Test by rotating shaft; grinding/loose shaft requires bearing replacement.</li> </ol>          |

## Operation

| PROBLEM  | POSSIBLE CAUSE   | CORRECTIVE ACTION  |
|--|--|--|
| Rip fence does not move smoothly.  | <ol style="list-style-type: none"> <li>1. Rip fence mounted/adjusted incorrectly.</li> <li>2. Rails dirty or sticky.</li> </ol>  | <ol style="list-style-type: none"> <li>1. Remount rip fence. Adjust fence (<b>Page 76</b>) to ensure adjustment screws are not too tight.</li> <li>2. Clean and wax rails.</li> </ol>  |
| Material moves away from fence when ripping.                                     | <ol style="list-style-type: none"> <li>1. Improper feeding technique.</li> <li>2. Fence not parallel with blade.</li> </ol>  | <ol style="list-style-type: none"> <li>1. Learn/use proper feeding technique.</li> <li>2. Adjust fence parallel with blade (<b>Page 75</b>).</li> </ol>  |
| Blade not parallel with miter slot.  | <ol style="list-style-type: none"> <li>1. Blade warped/damaged/dull.</li> </ol>  | <ol style="list-style-type: none"> <li>1. Replace blade (<b>Page 35</b>).</li> </ol>   |
| Blade tilt does not stop at 45°/90°.   | <ol style="list-style-type: none"> <li>1. 45°/90° stop out of adjustment. Sawdust built up in/on trunnions.</li> </ol>   | <ol style="list-style-type: none"> <li>1. Adjust 45°/90° stop (<b>Page 68</b>). Remove sawdust from trunnions. Clean and re-lubricate as necessary.</li> </ol>   |
| Blade hits table insert when tilting to 45°.                                     | <ol style="list-style-type: none"> <li>1. Sawdust/debris stuck in trunnion slides.</li> <li>2. Table/trunnion assembly mount position not correct.</li> <li>3. Miter slot not parallel with blade.</li> <li>4. Blade incorrectly installed.</li> </ol>   | <ol style="list-style-type: none"> <li>1. Clean sawdust or debris out of trunnion slides.</li> <li>2. Adjust table or trunnion mounting position (<b>Page 70</b>).</li> <li>3. Make miter slot parallel with blade; shim table (<b>Page 70</b>).</li> <li>4. Correctly install blade (<b>Page 35</b>).</li> </ol>  |
| Board binds or burns when feeding through table saw.                             | <ol style="list-style-type: none"> <li>1. Blade warped/damaged/dull.</li> <li>2. Too many teeth on blade for cutting type.</li> <li>3. Fence not parallel to blade.</li> <li>4. Miter slot not parallel with blade.</li> <li>5. Riving knife or spreader not correctly aligned with blade.</li> <li>6. Spreader not correctly aligned with blade.</li> </ol> | <ol style="list-style-type: none"> <li>1. Replace blade (<b>Page 35</b>).</li> <li>2. Change blade to one with fewer teeth.</li> <li>3. Adjust fence parallel with blade (<b>Page 75</b>).</li> <li>4. Make miter slot parallel with blade (<b>Page 70</b>).</li> <li>5. Adjust riving knife or spreader into alignment with blade (<b>Page 72</b>).</li> <li>6. Adjust spreader into alignment with blade (<b>Page 72</b>).</li> </ol>    |
| Handwheel binds or is difficult to move.   | <ol style="list-style-type: none"> <li>1. Lock knob is tightened.</li> <li>2. Handwheel shaft pins are wedged.</li> <li>3. Excessive dust/grease on worm gear/leadscrew/trunnion.</li> </ol>   | <ol style="list-style-type: none"> <li>1. Loosen lock knob.</li> <li>2. Remove handwheel and adjust shaft pins.</li> <li>3. Clean and re-grease worm gear/leadscrew/trunnion (<b>Page 67</b>).</li> </ol>  |
| Blade too close to insert.   | <ol style="list-style-type: none"> <li>1. Blade or arbor washers incorrectly installed on arbor.</li> <li>2. Table/trunnion assembly mount position not correct.</li> </ol>  | <ol style="list-style-type: none"> <li>1. Verify blade and arbor washers are correctly installed in required positions.</li> <li>2. Adjust table or trunnion mounting position (<b>Page 70</b>).</li> </ol>  |
| Blade will not go beneath table surface.   | <ol style="list-style-type: none"> <li>1. Roll pin/set screw in worm gear contacting geared trunnion.</li> <li>2. Excessive dust/grease on worm gear.</li> </ol>   | <ol style="list-style-type: none"> <li>1. Tighten roll pins and set screws in worm gear.</li> <li>2. Clean and re-grease worm gear (<b>Page 67</b>).</li> </ol>  |
| Too much sawdust blown back toward operator.                                     | <ol style="list-style-type: none"> <li>1. Blade guard removed.</li> <li>2. Too many air leaks in cabinet for proper dust collection.</li> <li>3. Dust collection system clogged or lacks required CFM at machine.</li> <li>4. Fence not parallel with blade (pressure at blade backside).</li> <li>5. Miter slot not parallel with blade.</li> </ol>         | <ol style="list-style-type: none"> <li>1. Re-install blade guard for maximum safety and dust control (<b>Page 37</b>).</li> <li>2. Seal leaks in cabinet or around blade guard dust port.</li> <li>3. Remove clog; revise ducting layout for improved suction; use a different dust collector.</li> <li>4. Adjust fence parallel with blade (<b>Page 75</b>).</li> <li>5. Make miter slot parallel with blade (<b>Page 70</b>).</li> </ol> |
| Workpiece catches on table/dado insert or table throat during cutting operation. | <ol style="list-style-type: none"> <li>1. Table/dado insert out of adjustment.</li> </ol>  | <ol style="list-style-type: none"> <li>1. Adjust table/dado insert so it is perfectly flush with table surface (<b>Page 78</b>).</li> </ol>  |

# Electrical Safety Instructions

These pages are current at the time of printing. However, in the spirit of improvement, we may make changes to the electrical systems of future machines. Compare the manufacture date of your machine to the one stated in this manual, and study this section carefully.

If there are differences between your machine and what is shown in this section, call Technical Support at (360) 734-3482 for assistance BEFORE making any changes to the wiring on your machine. An updated wiring diagram may be available. **Note:** Please gather the serial number and manufacture date of your machine before calling. This information can be found on the main machine label.

## WARNING

**SHOCK HAZARD.** Working on wiring that is connected to a power source is extremely dangerous. Touching electrified parts will result in personal injury including but not limited to severe burns, electrocution, or death. Disconnect the power from the machine before servicing electrical components!

**QUALIFIED ELECTRICIAN.** Due to the inherent hazards of electricity, only a qualified electrician should perform wiring tasks on this machine. If you are not a qualified electrician, get help from one before attempting any kind of wiring job.

**WIRE CONNECTIONS.** All connections must be tight to prevent wires from loosening during machine operation. Double-check all wires disconnected or connected during any wiring task to ensure tight connections.

**WIRE/COMPONENT DAMAGE.** Damaged wires or components increase the risk of serious personal injury, fire, or machine damage. If you notice that any wires or components are damaged while performing a wiring task, replace those wires or components before completing the task.

**MODIFICATIONS.** Using aftermarket parts or modifying the wiring beyond what is shown in the diagram may lead to unpredictable results, including serious injury or fire.

**MOTOR WIRING.** The motor wiring shown in these diagrams is current at the time of printing, but it may not match your machine. Always use the wiring diagram inside the motor junction box.

**CAPACITORS/INVERTERS.** Some capacitors and power inverters store an electrical charge for up to 10 minutes after being disconnected from the power source. To reduce the risk of being shocked, wait at least this long before working on capacitors.

**CIRCUIT REQUIREMENTS.** You MUST follow the requirements at the beginning of this manual when connecting your machine to a power source.

**EXPERIENCING DIFFICULTIES.** If you are experiencing difficulties understanding the information included in this section, contact our Technical Support at (360) 734-3482.

### NOTICE

The photos and diagrams included in this section are best viewed in color. You can view these pages in color at [www.shopfox.biz](http://www.shopfox.biz).

### WIRING DIAGRAM COLOR KEY

|       |        |              |            |
|-------|--------|--------------|------------|
| BLACK | BLUE   | YELLOW       | LIGHT BLUE |
| WHITE | BROWN  | YELLOW GREEN | BLUE WHITE |
| GREEN | GRAY   | PURPLE       | TUR-QUOISE |
| RED   | ORANGE | PINK         |            |

SERVICE

# Electrical Components

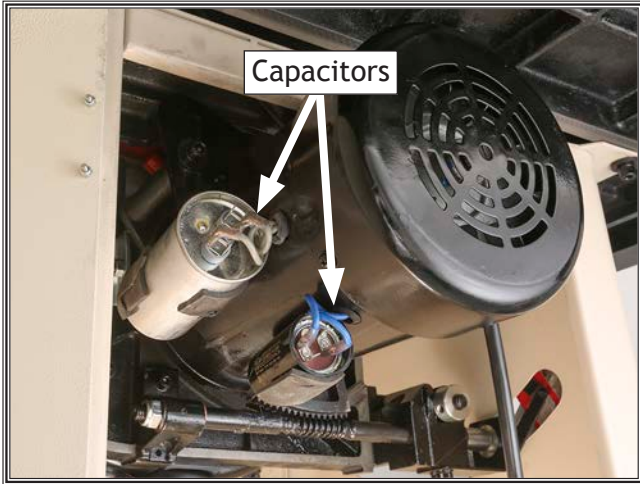


Figure 130. Motor capacitors.

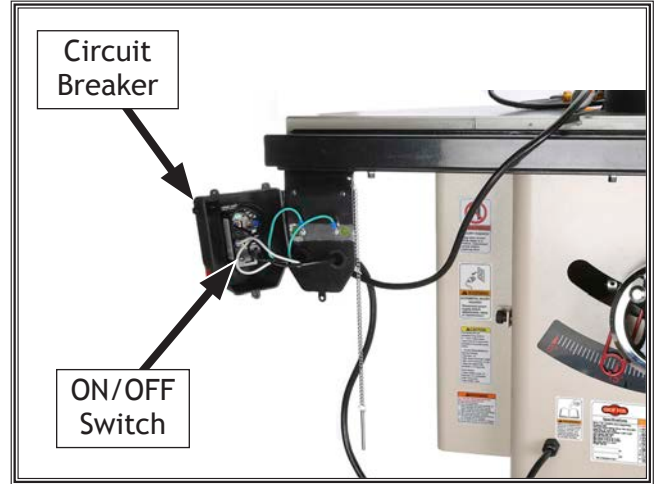


Figure 132. Switch box components.

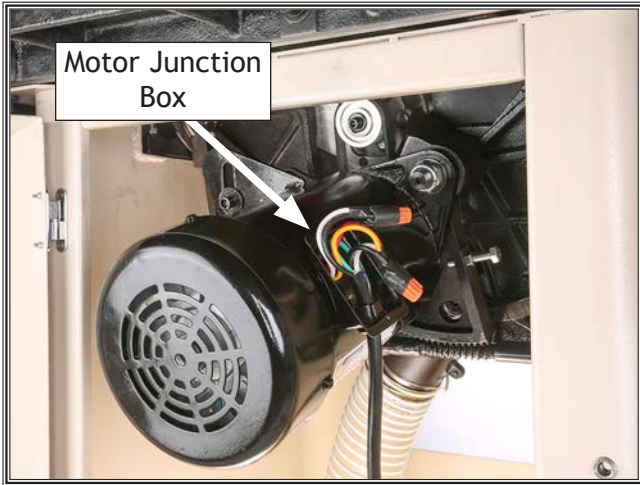
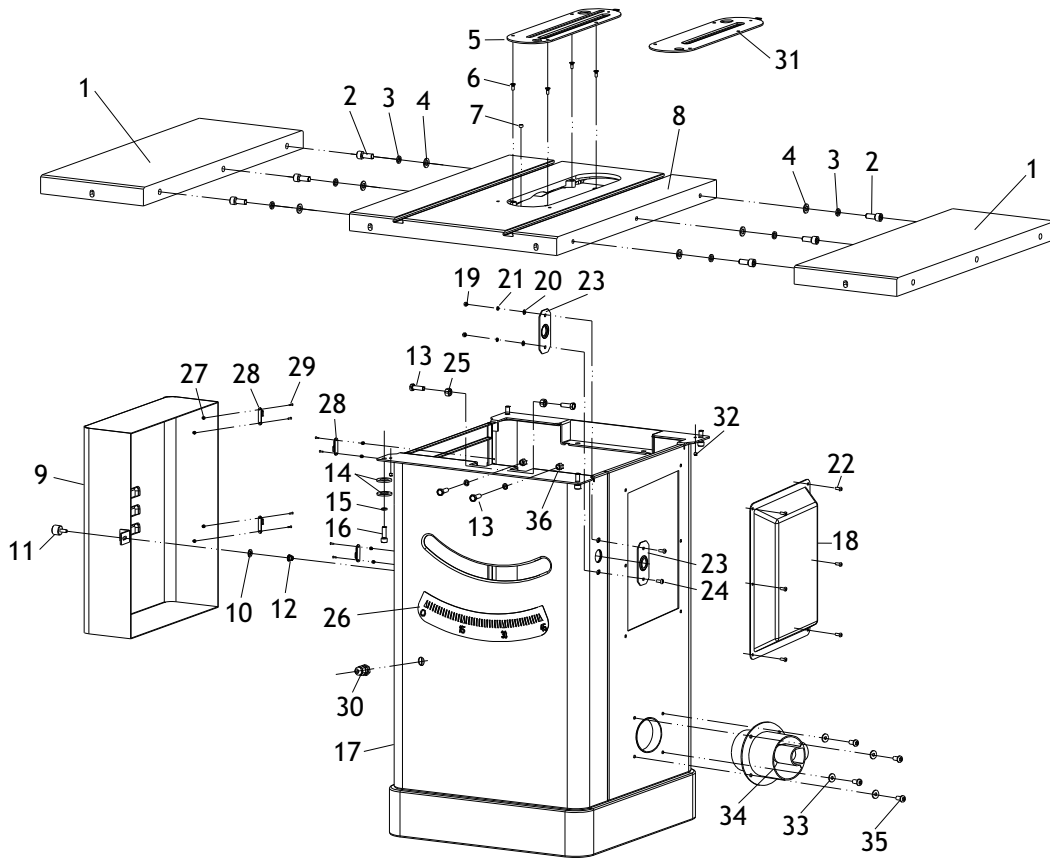


Figure 131. Motor junction box.



# PARTS

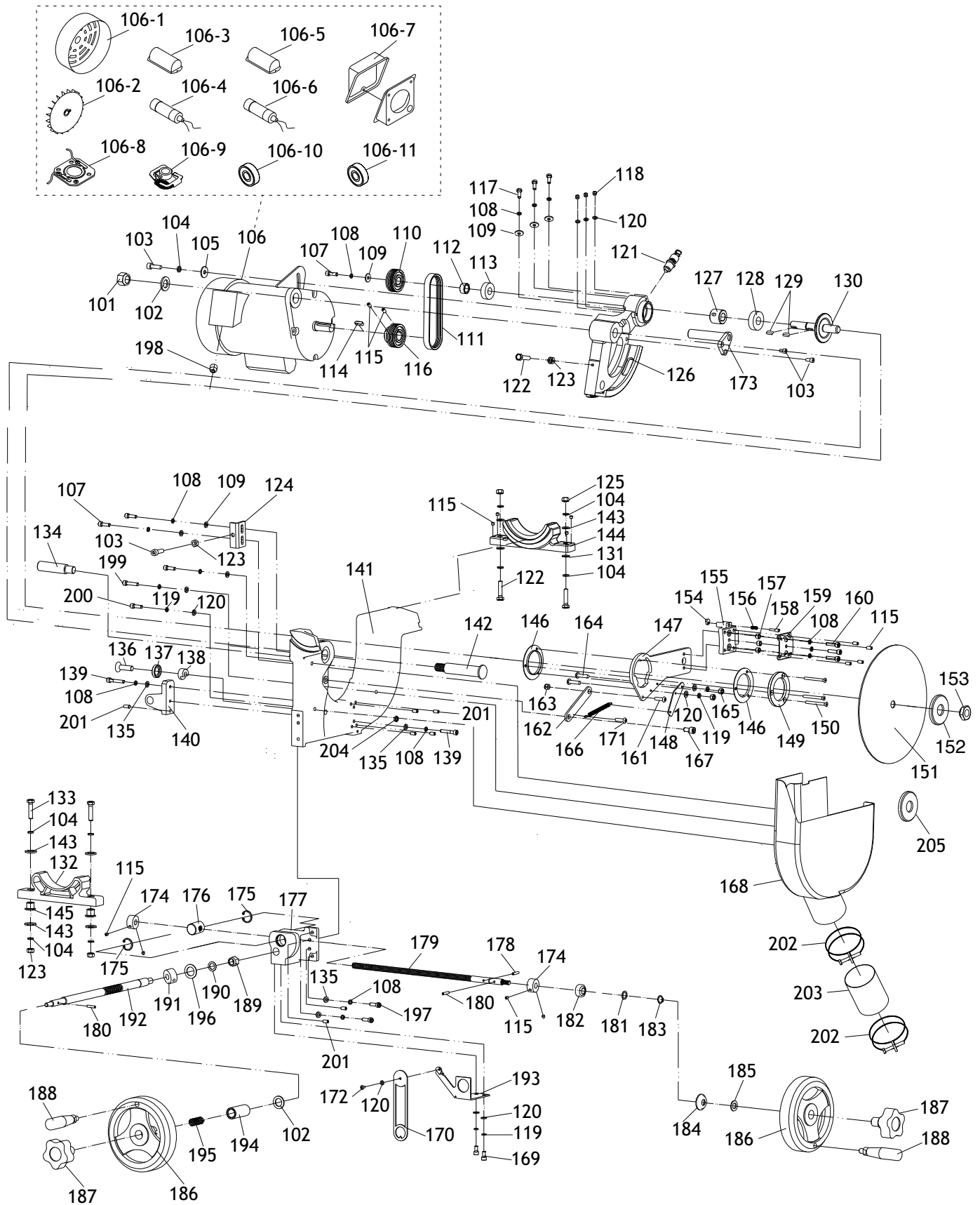
## Body



| REF | PART #   | DESCRIPTION                |
|-----|----------|----------------------------|
| 1   | X1851001 | EXTENSION WING             |
| 2   | X1851002 | CAP SCREW M10-1.5 X 30     |
| 3   | X1851003 | LOCK WASHER 10MM           |
| 4   | X1851004 | FLAT WASHER 10MM           |
| 5   | X1851005 | TABLE INSERT (STANDARD)    |
| 6   | X1851006 | FLAT HD CAP SCR M5-.8 X 10 |
| 7   | X1851007 | TABLE INSERT MAGNET        |
| 8   | X1851008 | MAIN TABLE                 |
| 9   | X1851009 | MOTOR COVER                |
| 10  | X1851010 | INT TOOTH WASHER 6MM       |
| 11  | X1851011 | KNOB M6-1                  |
| 12  | X1851012 | RIVETED NUT M6-1 X 15      |
| 13  | X1851013 | HEX BOLT M8-1.25 X 25      |
| 14  | X1851014 | FLAT WASHER 8MM            |
| 15  | X1851015 | LOCK WASHER 8MM            |
| 16  | X1851016 | CAP SCREW M8-1.25 X 25     |
| 17  | X1851017 | CABINET                    |
| 18  | X1851018 | ACCESS COVER               |

| REF | PART #   | DESCRIPTION                  |
|-----|----------|------------------------------|
| 19  | X1851019 | HEX NUT M5-.8                |
| 20  | X1851020 | FLAT WASHER 5MM              |
| 21  | X1851021 | LOCK WASHER 5MM              |
| 22  | X1851022 | BUTTON HD CAP SCR M5-.8 X 12 |
| 23  | X1851023 | LEADSCREW BRACKET            |
| 24  | X1851024 | BUTTON HD CAP SCR M5-.8 X 16 |
| 25  | X1851025 | LOCK NUT M8-1.25             |
| 26  | X1851026 | TILT SCALE                   |
| 27  | X1851027 | LOCK NUT M3-.5               |
| 28  | X1851028 | UPPER AND LOWER HINGE        |
| 29  | X1851029 | FLAT HD CAP SCR M3-.5 X 12   |
| 30  | X1851030 | STRAIN RELIEF TYPE-3 M18-1.5 |
| 31  | X1851031 | TABLE INSERT (DADO)          |
| 32  | X1851032 | SET SCREW M5-.8 X 8          |
| 33  | X1851033 | FLAT WASHER 6MM              |
| 34  | X1851034 | DUST PORT 4" X 1-1/2"        |
| 35  | X1851035 | BUTTON HD CAP SCR M6-1 X 12  |
| 36  | X1851036 | LOCK NUT M8-1.25             |

# Trunnion

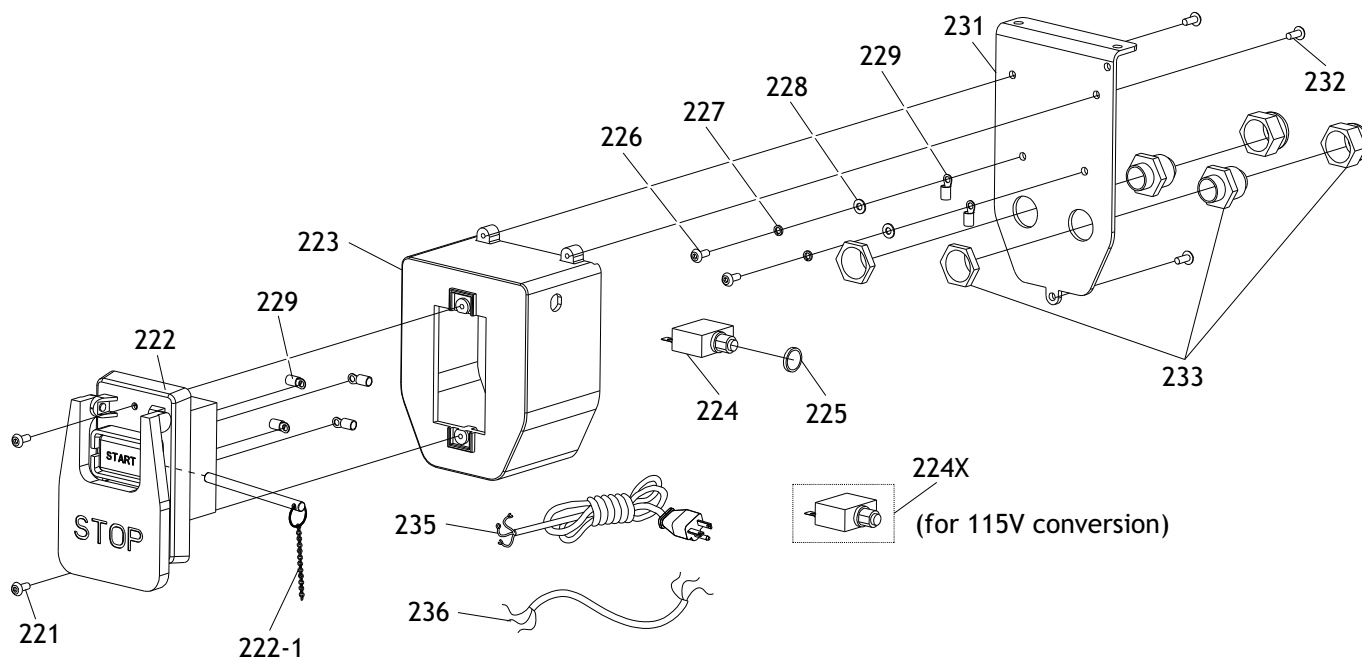


# Trunnion Parts List

| REF    | PART #      | DESCRIPTION                             |
|--------|-------------|---|
| 101    | X1851101    | LOCK NUT M16-2                          |
| 102    | X1851102    | FLAT WASHER 16MM                        |
| 103    | X1851103    | CAP SCREW M8-1.25 X 20                  |
| 104    | X1851104    | LOCK WASHER 8MM                         |
| 105    | X1851105    | FLAT WASHER 8MM                         |
| 106    | X1851106    | MOTOR 2HP 110V/220V 1-PH                |
| 106-1  | X1851106-1  | MOTOR FAN COVER                         |
| 106-2  | X1851106-2  | MOTOR FAN                               |
| 106-3  | X1851106-3  | START CAPACITOR COVER                   |
| 106-4  | X1851106-4  | S CAPACITOR 200-240M 250V 1-1/2 X 2-3/4 |
| 106-5  | X1851106-5  | RUN CAPACITOR COVER                     |
| 106-6  | X1851106-6  | R CAPACITOR 40M 450V 2 X 4              |
| 106-7  | X1851106-7  | MOTOR JUNCTION BOX                      |
| 106-8  | X1851106-8  | CONTACT PLATE                           |
| 106-9  | X1851106-9  | CENTRIFUGAL SWITCH                      |
| 106-10 | X1851106-10 | BALL BEARING 6203ZZ (FRONT)             |
| 106-11 | X1851106-11 | BALL BEARING 6204ZZ (REAR)              |
| 107    | X1851107    | CAP SCREW M6-1 X 16                     |
| 108    | X1851108    | LOCK WASHER 6MM                         |
| 109    | X1851109    | FLAT WASHER 6MM                         |
| 110    | X1851110    | ARBOR PULLEY                            |
| 111    | X1851111    | POLY V-BELT 150PJ6                      |
| 112    | X1851112    | BUSHING                                 |
| 113    | X1851113    | BALL BEARING 6203-2RS                   |
| 114    | X1851114    | KEY 6 X 6 X 20                          |
| 115    | X1851115    | SET SCREW M6-1 X 8                      |
| 116    | X1851116    | MOTOR PULLEY                            |
| 117    | X1851117    | HEX BOLT M6-1 X 16                      |
| 118    | X1851118    | LOCK NUT M5-.8                          |
| 119    | X1851119    | LOCK WASHER 5MM                         |
| 120    | X1851120    | FLAT WASHER 5MM                         |
| 121    | X1851121    | ARBOR LOCK                              |
| 122    | X1851122    | HEX BOLT M8-1.25 X 40                   |
| 123    | X1851123    | HEX NUT M8-1.25                         |
| 124    | X1851124    | HEIGHT LIMIT BLOCK                      |
| 125    | X1851125    | LOCK NUT M8-1.25                        |
| 126    | X1851126    | MOTOR MOUNT                             |
| 127    | X1851127    | ARBOR BUSHING                           |
| 128    | X1851128    | BALL BEARING 6202-2RS                   |
| 129    | X1851129    | KEY 5 X 5 X 15                          |
| 130    | X1851130    | ARBOR                                   |
| 131    | X1851131    | FLAT WASHER 8MM                         |
| 132    | X1851132    | FRONT TRUNNION                          |
| 133    | X1851133    | HEX BOLT M8-1.25 X 45                   |
| 134    | X1851134    | LIMIT BLOCK                             |
| 135    | X1851135    | FLAT WASHER 6MM                         |
| 136    | X1851136    | FLAT HD CAP SCR M10-1.5 X 40            |
| 137    | X1851137    | SPACER                                  |
| 138    | X1851138    | SPACER (NYLON)                          |
| 139    | X1851139    | CAP SCREW M6-1 X 35                     |
| 140    | X1851140    | SHAFT BRACKET                           |
| 141    | X1851141    | MAIN TRUNNION                           |
| 142    | X1851142    | MOTOR SHAFT                             |
| 143    | X1851143    | FLAT WASHER 8MM                         |
| 144    | X1851144    | REAR TRUNNION                           |
| 145    | X1851145    | ADJUSTMENT SCREW                        |
| 146    | X1851146    | NYLON GASKET                            |
| 147    | X1851147    | SPREADER BRACKET                        |

| REF | PART #   | DESCRIPTION                              |
|-----|----------|--|
| 148 | X1851148 | SPRING BRACKET                           |
| 149 | X1851149 | FLANGE RING                              |
| 150 | X1851150 | FLAT HD CAP SCR M5-.8 X 50               |
| 151 | X1851151 | SAW BLADE 10" X 40T                      |
| 152 | X1851152 | ARBOR FLANGE 7.2MM THICK (STD)           |
| 153 | X1851153 | ARBOR NUT M16-2                          |
| 154 | X1851154 | KNURLED KNOB                             |
| 155 | X1851155 | SPREADER ADJUSTMENT BLOCK                |
| 156 | X1851156 | COMPRESSION SPRING                       |
| 157 | X1851157 | SPACER                                   |
| 158 | X1851158 | LOCKING PIN 6 X 26                       |
| 159 | X1851159 | SPREADER CLAMPING PLATE                  |
| 160 | X1851160 | CAP SCREW M6-1 X 25                      |
| 161 | X1851161 | BUTTON HD CAP SCR M6-1 X 20              |
| 162 | X1851162 | CONNECTING PLATE                         |
| 163 | X1851163 | LOCK NUT M6-1                            |
| 164 | X1851164 | BUTTON HD CAP SCR M5-.8 X 16             |
| 165 | X1851165 | HEX NUT M5-.8                            |
| 166 | X1851166 | EXTENSION SPRING                         |
| 167 | X1851167 | SHOULDER SCREW M6-1 X 16, 6 X 12         |
| 168 | X1851168 | DUST COLLECTOR CASE                      |
| 169 | X1851169 | CAP SCREW M5-.8 X 12                     |
| 170 | X1851170 | POINTER                                  |
| 171 | X1851171 | BUTTON HD CAP SCR M5-.8 X 12             |
| 172 | X1851172 | BUTTON HD CAP SCR M4-.7 X 8              |
| 173 | X1851173 | MOTOR LOCATING SHAFT                     |
| 174 | X1851174 | STOP COLLAR                              |
| 175 | X1851175 | INT RETAINING RING 24MM                  |
| 176 | X1851176 | TILT LEADSCREW NUT                       |
| 177 | X1851177 | TILT LEADSCREW BASE                      |
| 178 | X1851178 | ROLL PIN 4 X 16                          |
| 179 | X1851179 | TILT LEADSCREW                           |
| 180 | X1851180 | ROLL PIN 4 X 20                          |
| 181 | X1851181 | FLAT WASHER 12MM                         |
| 182 | X1851182 | BEARING WASHER                           |
| 183 | X1851183 | EXT RETAINING RING 12MM                  |
| 184 | X1851184 | BEVELED BUSHING                          |
| 185 | X1851185 | FLAT WASHER 12MM                         |
| 186 | X1851186 | HANDWHEEL TYPE-7 160D X 11.5BK X M10-1.5 |
| 187 | X1851187 | HANDWHEEL LOCK KNOB M8-1.25 5-LOBE       |
| 188 | X1851188 | HANDWHEEL HANDLE 90L, M10-1.5 X 12       |
| 189 | X1851189 | LOCK NUT M12-1.75                        |
| 190 | X1851190 | FLAT WASHER 12MM                         |
| 191 | X1851191 | COLLAR                                   |
| 192 | X1851192 | ELEVATION SHAFT                          |
| 193 | X1851193 | POINTER BASE                             |
| 194 | X1851194 | HANDWHEEL BUSHING                        |
| 195 | X1851195 | COMPRESSION SPRING                       |
| 196 | X1851196 | ELEVATION SHAFT SPACER                   |
| 197 | X1851197 | CAP SCREW M6-1 X 20                      |
| 198 | X1851198 | STRAIN RELIEF TYPE-1 3/8"                |
| 199 | X1851199 | CAP SCREW M5-.8 X 30                     |
| 200 | X1851200 | CAP SCREW M5-.8 X 20                     |
| 201 | X1851201 | SET SCREW M6-1 X 20                      |
| 202 | X1851202 | HOSE CLAMP 3-1/4"                        |
| 203 | X1851203 | CLEAR HOSE 26" X 3"                      |
| 204 | X1851204 | HEX NUT M10-1.5                          |
| 205 | X1851205 | ARBOR FLANGE 5MM THICK (DADO)            |

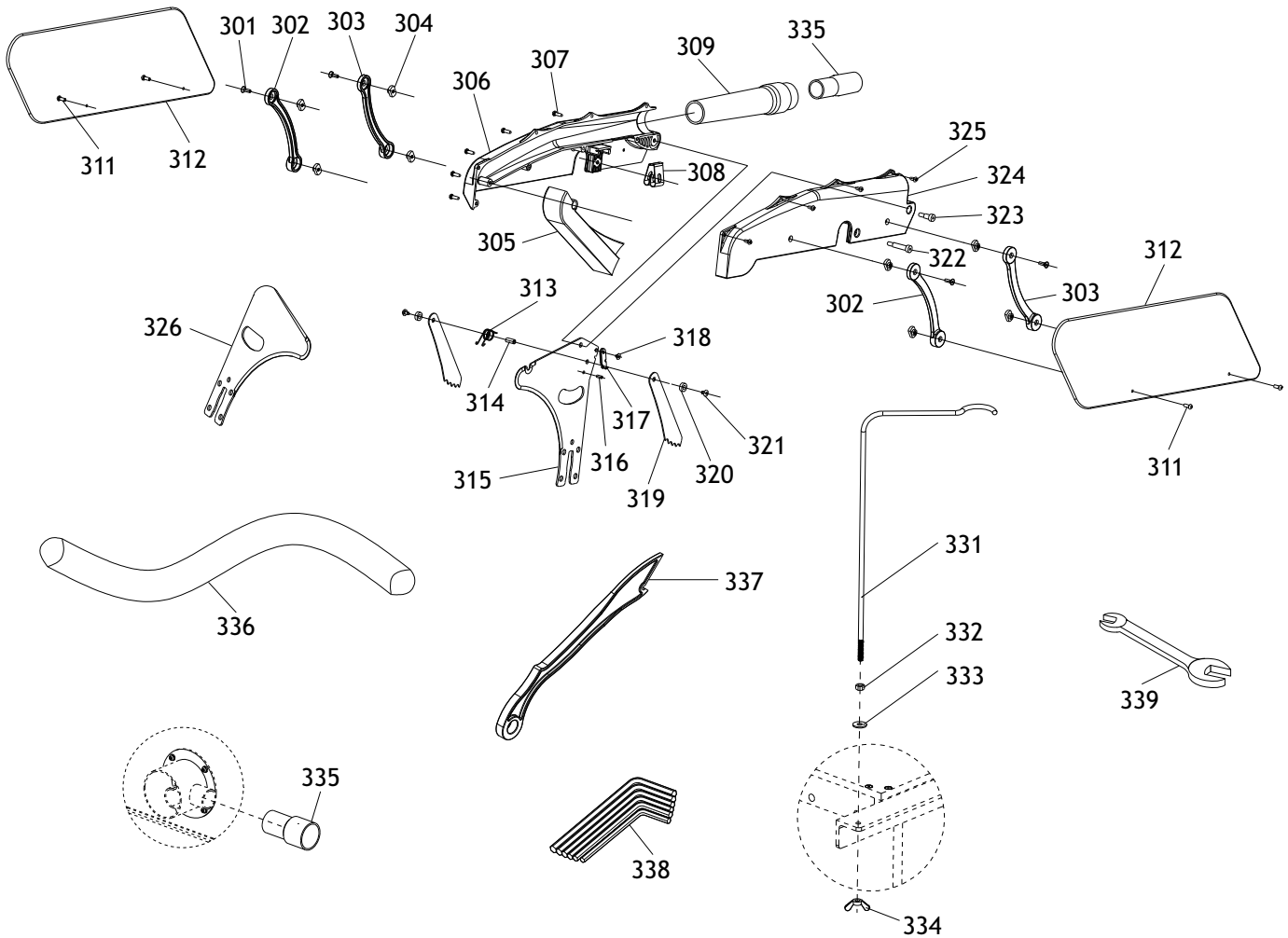
# Power Switch



| REF   | PART #     | DESCRIPTION                        |
|-------|------------|------------------------------------|
| 221   | X1851221   | TAP SCREW M3.5 X 19                |
| 222   | X1851222   | S/S SWITCH W/STOP PADDLE KEDU HY56 |
| 222-1 | X1851222-1 | PADDLE SWITCH LOCKOUT PIN          |
| 223   | X1851223   | SWITCH BOX                         |
| 224   | X1851224   | CIRCUIT BREAKER KUOYUH 88 10A 230V |
| 224X  | X1851224X  | CIRCUIT BREAKER KUOYUH 88 20A 115V |
| 225   | X1851225   | CIRCUIT BREAKER NUT M10-1.5        |
| 226   | X1851226   | PHLP HD SCR M4-.7 X 8              |

| REF | PART #   | DESCRIPTION                  |
|-----|----------|------------------------------|
| 227 | X1851227 | LOCK WASHER 4MM              |
| 228 | X1851228 | FLAT WASHER 4MM              |
| 229 | X1851229 | CLAMP-ON TERMINAL RING       |
| 231 | X1851231 | SWITCH BRACKET               |
| 232 | X1851232 | TAP SCREW M3.5 X 10          |
| 233 | X1851233 | STRAIN RELIEF TYPE-3 M18-1.5 |
| 235 | X1851235 | POWER CORD 14G 3W 72" 6-20P  |
| 236 | X1851236 | MOTOR CORD 14G 3W 32"        |

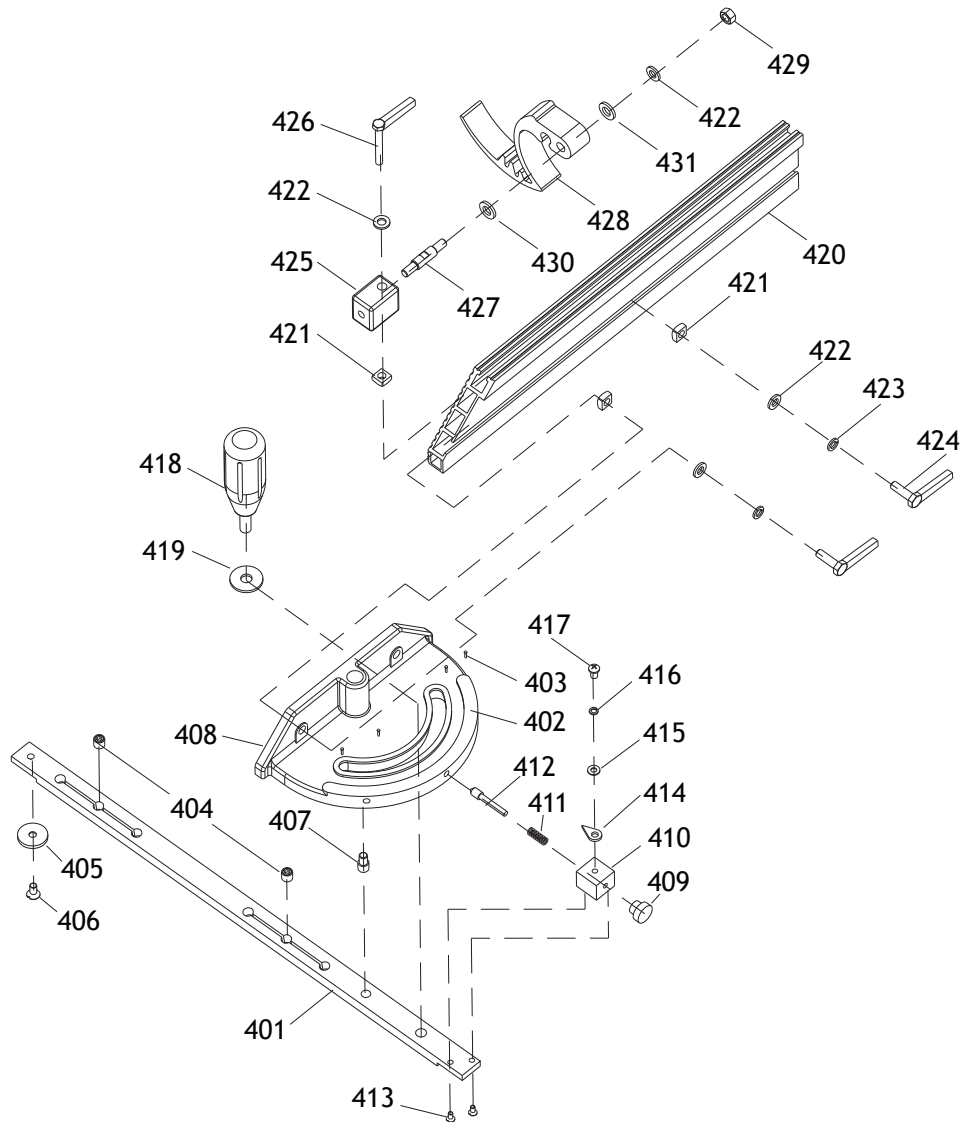
# Blade Guard



| REF | PART #   | DESCRIPTION                  |
|-----|----------|------------------------------|
| 301 | X1851301 | FLAT HD CAP SCR M4-.7 X 10   |
| 302 | X1851302 | GUARD SUPPORT (FRONT)        |
| 303 | X1851303 | GUARD SUPPORT (REAR)         |
| 304 | X1851304 | FLANGE NUT M4-.7             |
| 305 | X1851305 | DUST CHUTE                   |
| 306 | X1851306 | LEFT GUARD                   |
| 307 | X1851307 | TAP SCREW M3.5 X 16          |
| 308 | X1851308 | SPRING CLAMP                 |
| 309 | X1851309 | BLADE GUARD DUST PORT        |
| 311 | X1851311 | BUTTON HD CAP SCR M4-.7 X 10 |
| 312 | X1851312 | SIDE GUARD                   |
| 313 | X1851313 | TORSION SPRING               |
| 314 | X1851314 | PAWL SHAFT                   |
| 315 | X1851315 | SPREADER                     |
| 316 | X1851316 | ROLL PIN 4 X 16              |
| 317 | X1851317 | PAWL RELEASE HOOK            |
| 318 | X1851318 | RIVET 4 X 8                  |

| REF | PART #   | DESCRIPTION                        |
|-----|----------|------------------------------------|
| 319 | X1851319 | ANTI-KICKBACK PAWL                 |
| 320 | X1851320 | SPACER                             |
| 321 | X1851321 | BUTTON HD CAP SCR M4-.7 X 6        |
| 322 | X1851322 | SHOULDER SCREW M5-.8 X 10, 11 X 35 |
| 323 | X1851323 | SHOULDER SCREW M5-.8 X 10, 11 X 20 |
| 324 | X1851324 | RIGHT GUARD                        |
| 325 | X1851325 | TAP SCREW M3 X 10                  |
| 326 | X1851326 | RIVING KNIFE                       |
| 331 | X1851331 | HOSE SUPPORT ARM                   |
| 332 | X1851332 | HEX NUT M6-1                       |
| 333 | X1851333 | FLAT WASHER 6MM                    |
| 334 | X1851334 | WING NUT M6-1                      |
| 335 | X1851335 | HOSE CONNECTOR 1-1/2"              |
| 336 | X1851336 | DUST HOSE 94" X 1-1/2"             |
| 337 | X1851337 | PUSH STICK                         |
| 338 | X1851338 | HEX WRENCH SET 2.5-8MM (6-PC)      |
| 339 | X1851339 | WRENCH 13 X 27MM OPEN-ENDS         |

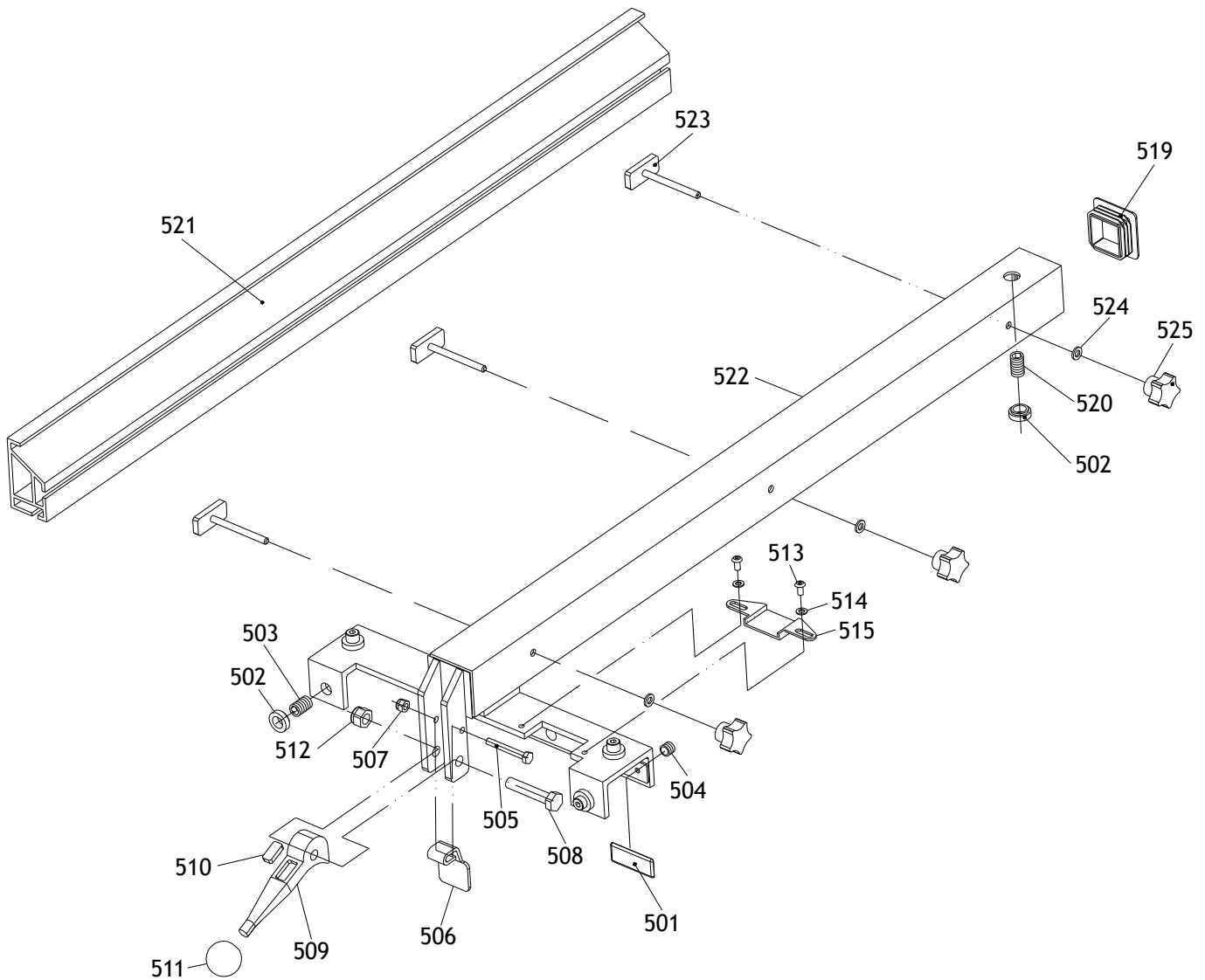
# Miter Guage



| REF | PART #   | DESCRIPTION                  |
|-----|----------|------------------------------|
| 401 | X1851401 | GUIDE BAR                    |
| 402 | X1851402 | ANGLE SCALE                  |
| 403 | X1851403 | RIVET 2.5 X 8 BLIND, STEEL   |
| 404 | X1851404 | SET SCREW M8-1.25 X 6        |
| 405 | X1851405 | MITER RING                   |
| 406 | X1851406 | FLAT HD CAP SCR M5-.8 X 8    |
| 407 | X1851407 | MITER BODY PIVOT PIN         |
| 408 | X1851408 | MITER GAUGE BODY             |
| 409 | X1851409 | MITER STOP PIN KNOB          |
| 410 | X1851410 | PIN BLOCK                    |
| 411 | X1851411 | COMPRESSION SPRING           |
| 412 | X1851412 | MITER STOP PIN               |
| 413 | X1851413 | BUTTON HD CAP SCR M4-.7 X 10 |
| 414 | X1851414 | MITER GAUGE POINTER          |
| 415 | X1851415 | FLAT WASHER 4MM              |
| 416 | X1851416 | LOCK WASHER 4MM              |

| REF | PART #   | DESCRIPTION                 |
|-----|----------|-----------------------------|
| 417 | X1851417 | BUTTON HD CAP SCR M4-.7 X 6 |
| 418 | X1851418 | LOCKING HANDLE M8-1.25 X 24 |
| 419 | X1851419 | FLAT WASHER 8MM             |
| 420 | X1851420 | MITER GAUGE FENCE           |
| 421 | X1851421 | T-NUT M6-1                  |
| 422 | X1851422 | FLAT WASHER 6MM             |
| 423 | X1851423 | LOCK WASHER 6MM             |
| 424 | X1851424 | LOCK LEVER M6-1 X 25        |
| 425 | X1851425 | FLIP STOP BRACKET           |
| 426 | X1851426 | LOCK LEVER M6-1 X 32        |
| 427 | X1851427 | FLIP STOP PIVOT SHAFT       |
| 428 | X1851428 | FLIP STOP                   |
| 429 | X1851429 | LOCK NUT M6-1               |
| 430 | X1851430 | FLAT WASHER 8MM TEFLON      |
| 431 | X1851431 | FLAT WASHER 6MM TEFLON      |

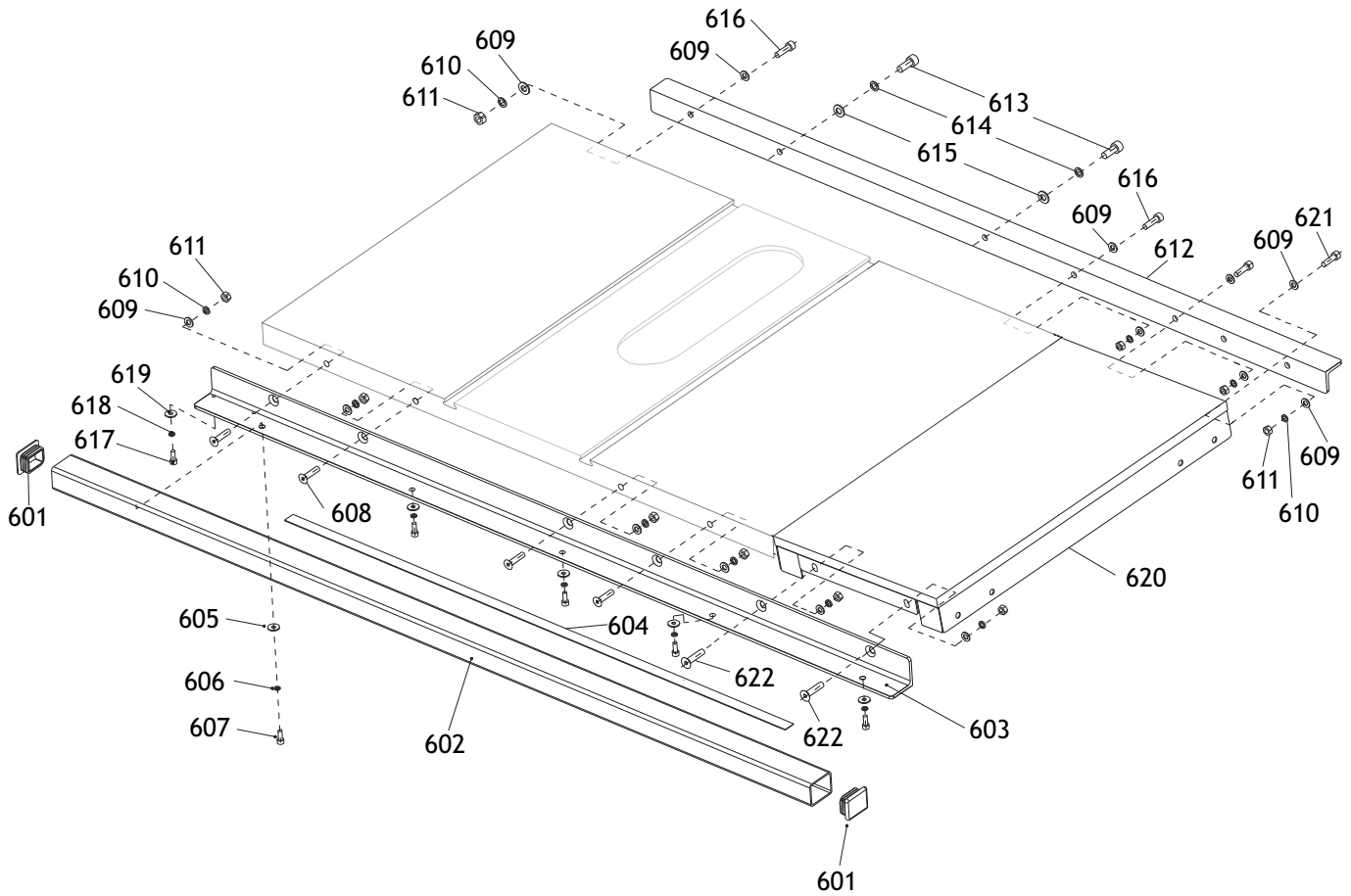
# Fence



| REF | PART #   | DESCRIPTION             |
|-----|----------|-------------------------|
| 501 | X1851501 | GLIDE PAD               |
| 502 | X1851502 | KNURLED NUT M12-1.75    |
| 503 | X1851503 | SET SCREW M12-1.75 X 16 |
| 504 | X1851504 | SET SCREW M12-1.75 X 10 |
| 505 | X1851505 | HEX BOLT M6-1 X 40      |
| 506 | X1851506 | CAM LOCK PLATE          |
| 507 | X1851507 | LOCK NUT M6-1           |
| 508 | X1851508 | HEX BOLT M10-1.5 X 45   |
| 509 | X1851509 | FENCE LOCK CAM LEVER    |
| 510 | X1851510 | MAGNET                  |
| 511 | X1851511 | BALL KNOB M10-1.5       |

| REF | PART #   | DESCRIPTION                  |
|-----|----------|------------------------------|
| 512 | X1851512 | LOCK NUT M10-1.5             |
| 513 | X1851513 | BUTTON HD CAP SCR M5-.8 X 8  |
| 514 | X1851514 | FLAT WASHER 5MM              |
| 515 | X1851515 | FENCE SCALE WINDOW           |
| 519 | X1851519 | FENCE BASE END CAP 50 X 50MM |
| 520 | X1851520 | SET SCREW M12-1.75 X 30      |
| 521 | X1851521 | FENCE FACE                   |
| 522 | X1851522 | FENCE BASE                   |
| 523 | X1851523 | FENCE T-BOLT M6-1 X 30       |
| 524 | X1851524 | FLAT WASHER 6MM              |
| 525 | X1851525 | KNOB 5-LOBE M6-1 X 30        |

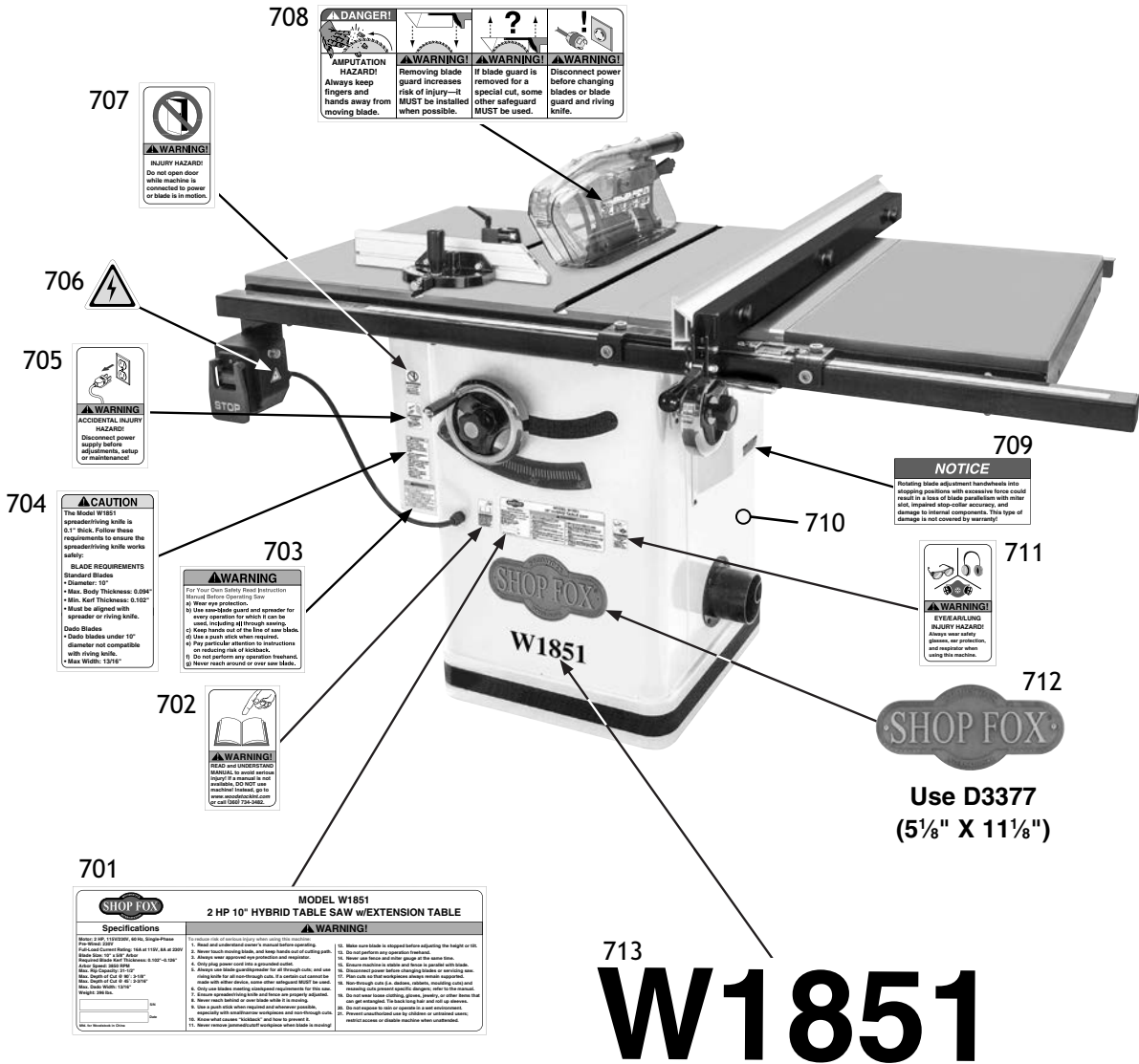
# Fence Rails



| REF | PART #   | DESCRIPTION                  |
|-----|----------|------------------------------|
| 601 | X1851601 | GUIDE-TUBE END CAP 50 X 40MM |
| 602 | X1851602 | FENCE GUIDE TUBE             |
| 603 | X1851603 | FRONT FENCE RAIL             |
| 604 | X1851604 | FENCE SCALE LABEL            |
| 605 | X1851605 | FLAT WASHER 6MM              |
| 606 | X1851606 | LOCK WASHER 6MM              |
| 607 | X1851607 | CAP SCREW M6-1 X 16          |
| 608 | X1851608 | FLAT HD CAP SCR M8-1.25 X 35 |
| 609 | X1851609 | FLAT WASHER 8MM              |
| 610 | X1851610 | LOCK WASHER 8MM              |
| 611 | X1851611 | HEX NUT M8-1.25              |

| REF | PART #   | DESCRIPTION                  |
|-----|----------|------------------------------|
| 612 | X1851612 | REAR FENCE RAIL              |
| 613 | X1851613 | CAP SCREW M10-1.5 X 25       |
| 614 | X1851614 | LOCK WASHER 10MM             |
| 615 | X1851615 | FLAT WASHER 10MM             |
| 616 | X1851616 | CAP SCREW M8-1.25 X 35       |
| 617 | X1851617 | CAP SCREW M5-.8 X 14         |
| 618 | X1851618 | LOCK WASHER 5MM              |
| 619 | X1851619 | FLAT WASHER 5MM              |
| 620 | X1851620 | EXTENSION TABLE              |
| 621 | X1851621 | CAP SCREW M8-1.25 X 25       |
| 622 | X1851622 | FLAT HD CAP SCR M8-1.25 X 20 |

# Labels & Cosmetics



# W1851

| REF | PART #   | DESCRIPTION                   |
|-----|----------|-------------------------------|
| 701 | X1851701 | MACHINE ID LABEL              |
| 702 | X1851702 | READ MANUAL LABEL             |
| 703 | X1851703 | TABLE SAW WARNING LABEL       |
| 704 | X1851704 | RIVING KNIFE CAUTION LABEL    |
| 705 | X1851705 | DISCONNECT POWER LABEL        |
| 706 | X1851706 | ELECTRICITY LABEL             |
| 707 | X1851707 | DON'T OPEN DOOR WARNING LABEL |

| REF | PART #   | DESCRIPTION                    |
|-----|----------|--------------------------------|
| 708 | X1851708 | BLADE GUARD LABEL              |
| 709 | X1851709 | HANDWHEELS NOTICE LABEL        |
| 710 | X1851710 | TOUCH-UP PAINT, SHOP FOX WHITE |
| 711 | X1851711 | EYE/LUNG HAZARD LABEL          |
| 712 | X1851712 | SHOP FOX NAMEPLATE D3377       |
| 713 | X1851713 | MODEL NUMBER LABEL             |

**⚠ WARNING**

Safety labels warn about machine hazards and how to prevent serious personal injury. The owner of this machine **MUST** maintain the original location and readability of all labels on this machine. If any label is removed or becomes unreadable, **REPLACE** that label before allowing machine to be operated again. Contact us at (360) 734-3482 or [www.woodstockint.com](http://www.woodstockint.com) to order new labels.



# Warranty Registration

Name \_\_\_\_\_  
 Street \_\_\_\_\_  
 City \_\_\_\_\_ State \_\_\_\_\_ Zip \_\_\_\_\_  
 Phone # \_\_\_\_\_ Email \_\_\_\_\_ Invoice # \_\_\_\_\_  
 Model # \_\_\_\_\_ Serial # \_\_\_\_\_ Dealer Name \_\_\_\_\_ Purchase Date \_\_\_\_\_

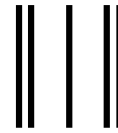
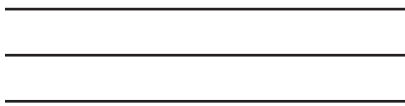
The following information is given on a voluntary basis. It will be used for marketing purposes to help us develop better products and services. Of course, all information is strictly confidential.

- How did you learn about us?  
 Advertisement       Friend       Local Store  
 Mail Order Catalog       Website       Other:
- How long have you been a woodworker/metalworker?  
 0-2 Years       2-8 Years       8-20 Years       20+ Years
- How many of your machines or tools are Shop Fox?  
 0-2       3-5       6-9       10+
- Do you think your machine represents a good value?       Yes       No
- Would you recommend Shop Fox products to a friend?       Yes       No
- What is your age group?  
 20-29       30-39       40-49  
 50-59       60-69       70+
- What is your annual household income?  
 \$20,000-\$29,000       \$30,000-\$39,000       \$40,000-\$49,000  
 \$50,000-\$59,000       \$60,000-\$69,000       \$70,000+
- Which of the following magazines do you subscribe to?  
 Cabinet Maker       Popular Mechanics       Today's Homeowner  
 Family Handyman       Popular Science       Wood  
 Hand Loader       Popular Woodworking       Wooden Boat  
 Handy       Practical Homeowner       Woodshop News  
 Home Shop Machinist       Precision Shooter       Woodsmith  
 Journal of Light Cont.       Projects in Metal       Woodwork  
 Live Steam       RC Modeler       Woodworker West  
 Model Airplane News       Rifle       Woodworker's Journal  
 Modeltec       Shop Notes       Other:  
 Old House Journal       Shotgun News

9. Comments: \_\_\_\_\_  
 \_\_\_\_\_  
 \_\_\_\_\_  
 \_\_\_\_\_  
 \_\_\_\_\_

CUT ALONG DOTTED LINE

FOLD ALONG DOTTED LINE



Place  
Stamp  
Here



WOODSTOCK INTERNATIONAL INC.  
P.O. BOX 2309  
BELLINGHAM, WA 98227-2309



FOLD ALONG DOTTED LINE

TAPE ALONG EDGES--PLEASE DO NOT STAPLE

# WARRANTY

Woodstock International, Inc. warrants all Shop Fox machinery to be free of defects from workmanship and materials for a period of two years from the date of original purchase by the original owner. This warranty does not apply to defects due directly or indirectly to misuse, abuse, negligence or accidents, lack of maintenance, or reimbursement of third party expenses incurred.

Woodstock International, Inc. will repair, replace, or arrange for a dealer refund, at its expense and option, the Shop Fox machine or machine part proven to be defective for its designed and intended use, provided that the original owner returns the product prepaid to an authorized warranty or repair facility as designated by our Bellingham, Washington office with proof of their purchase of the product within two years, and provides Woodstock International, Inc. reasonable opportunity to verify the alleged defect through inspection. If it is determined there is no defect, or that the defect resulted from causes not within the scope of Woodstock International Inc.'s warranty, then the original owner must bear the cost of storing and returning the product.

This is Woodstock International, Inc.'s sole written warranty and any and all warranties that may be implied by law, including any merchantability or fitness, for any particular purpose, are hereby limited to the duration of this written warranty. We do not warrant that Shop Fox machinery complies with the provisions of any law, acts or electrical codes. We do not reimburse for third party repairs. In no event shall Woodstock International, Inc.'s liability under this limited warranty exceed the purchase price paid for the product, and any legal actions brought against Woodstock International, Inc. shall be tried in the State of Washington, County of Whatcom. We shall in no event be liable for death, injuries to persons or property or for incidental, contingent, special or consequential damages arising from the use of our products.

Every effort has been made to ensure that all Shop Fox machinery meets high quality and durability standards. We are committed to continuously improving the quality of our products, and reserve the right to change specifications at any time.



## High Quality Machines and Tools

Woodstock International, Inc. carries thousands of products designed to meet the needs of today's woodworkers and metalworkers.

Ask your dealer about these fine products:

**BROSMAN**  
PRECISION STOP BLOCK

**JOINTER PAL**<sup>®</sup>

**Rotacator**<sup>®</sup>

**THE REBEL**<sup>®</sup>

**DURASTICK**<sup>®</sup>

**Gutmann**<sup>®</sup>

**BOARD BUDDIES**<sup>®</sup>

*Junglee*<sup>®</sup>

**PLANER PAL**<sup>®</sup>



**PARROT VISE**<sup>®</sup>

**SLICKPLANE**<sup>®</sup>

**PRO-STIK**<sup>®</sup>  
ABRASIVE BELT & DISC CLEANER

**ACCU-SHARP**<sup>®</sup>



**STEELEX**<sup>®</sup>  
*PLUS*

**STEELEX**<sup>®</sup>  
FINE TOOLS

*Aluma-Classic*<sup>®</sup>

**WHOLESALE ONLY**

**WOODSTOCK INTERNATIONAL, INC.**

Phone: (360) 734-3482 • Fax: (360) 671-3053 • Toll Free Fax: (800) 647-8801

P.O.Box 2309 • Bellingham, WA 98227

**SHOPFOX.BIZ**