

Installation Instructions

1801500 2.5" Receiver Hitch

Applications

2001 & Newer GM 3500 HD C&C with 34" Frames
 2007 & Newer Dodge RAM 3500 HD C&C with 34" Frames
 2008 & Newer Dodge RAM 4500/5500 HD C&C with 34" Frames

Capacity

22,000 lbs. Maximum Gross Trailer Weight (MGTW)
 3,000 lbs. Maximum Vertical Load (MVL)

For Dodge Ram Cab and Chassis

1. Remove the license plate bracket for now and give it to the original owner.
2. Remove the rivet farthest from the cab on the bottom of the frame rail. Rivet holes need to be drilled bigger in next step.
3. Raise the hitch into place, place the rear edges of the horizontal flanges flush to the end of the frame rails. Clamp it to the frame rail.
4. Using the hitch as a template, drill 3 holes on the side as shown.
5. Install the 5/8" carriage bolts (3), the square hole spacers (4), and the 5/8" flange nuts (5) onto the holes just drilled earlier.
6. Torque the 5/8 bolts to 160 ft-lbs.
7. Periodically check for loosened bolts and nuts. Make sure they are tightened.

For GM Cab & Chassis

1. Remove the license plate bracket for now and return it to the original owner.
2. Remove the two rear-most fuel tank shield bolts from the frame rail and return it to the original owner.
 A bottom support apparatus should be used to prevent fuel tank shield from falling.
3. Remove the rear-most rivet on the bottom of the frame rail about 3-1/2" from the end of the rails. This rivet matches the rear most holes of the hitch.
4. Raise the hitch into position – with two options below.
 - a. Matching the 1 inch diameter slot with the rivet on the bottom of the frame rail. Clamp into place.
 - b. Matching the rear most rivet hole removed earlier. Clamp into place.
5. Using the hitch as a template, drill bigger diameter for three 5/8" holes on each side of the frame rail.
6. Install the 5/8" carriage bolts (3), the square hole spacers (4), and the 5/8" flange nuts (5) onto the holes just drilled earlier.
7. Torque the 5/8 bolts to 160 ft-lbs.
8. Periodically check for loosened bolts and nuts. Make sure they are tightened.

WARNING

To avoid serious injury or death, check that all hitch fasteners are secure and properly torqued before use.

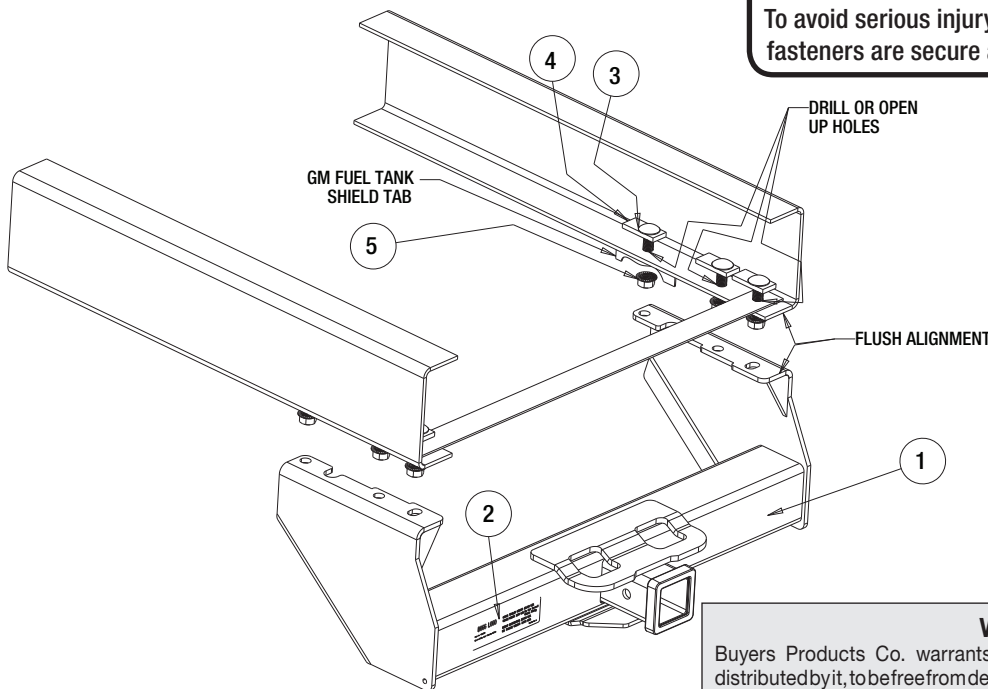

Bill of Materials

ITEM	PART NO.	QTY.	DESCRIPTION
1	3038915	1	HITCH, WELDMENT
2	3038920	1	LABEL, HITCH, 20K LB. GM CAB&CHAS
3	3038887	6	CARRIAGE BOLT, 5/8-11 X 2IN, G8
4	3038927	6	SPACER, 5/8 CARRIAGE BOLT, SQ HOLE
5	3038931	6	NUT, HEX, SERR, FLGE, 5/8-11, G8, ZN

WARRANTY

Buyers Products Co. warrants all truck/trailer hardware manufactured or distributed by it, to be free from defects in material and workmanship for a period of one year from date of shipment. Parts must be properly installed and used under normal conditions. Any product which has been altered, including modification, misuse, accident or lack of maintenance will not be considered under warranty. Normal wear is excluded. The sole responsibility of Buyers Products Co. under this warranty is limited to repairing or replacing any part or parts which are returned, prepaid, and are found to be defective by Buyers Products Co. Authorization from Buyers Products Co. must be obtained before returning any part. No charges for transportation or labor performed on Buyers' products will be allowed under this warranty.