

KBWC

Wall-Mount Series

Solid-State

Variable Speed AC Motor Controls

**For Use with Shaded Pole,
Permanent Split Capacitor (PSC)
and Universal Motors**

Ratings: 2.5 thru 15.0 Amps
115 and 230 VAC – 50/60 Hz

TYPICAL APPLICATIONS

- Fans • Fireplace Blowers • Humidifiers • Air Conditioners
- Ceiling Fans • Attic Fans
- Ventilators • Range Hoods

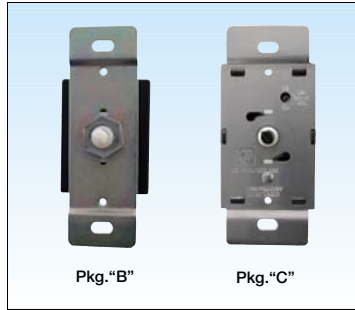

Pkg. "B"

Pkg. "C"



Dial Plate & Knob Pkgs. "B" & "C"



Pkg. "E"



Pkg. "D"

STANDARD FEATURES

- Built-In On/Off AC Line Switch
- Minimum Speed Trimptot
- RFI Filter (Provides RFI and EMI Suppression)
- All Models Mount in a Standard 2" x 4" Electrical Wall Box
- Agency Approvals*
 - UL Listing / Recognition
 - CSA Certified
 - ISO-9001: 2000 QMS Certified

OPTIONAL FEATURES (See Options Table)

- Custom Packaging
- Special Lead Lengths, Colors, and Terminations

DESCRIPTION



The KBWC Series is a comprehensive line of motor speed controls for air-moving applications that utilize Shaded Pole, Permanent Split Capacitor (PSC), and AC/DC motors. These economical speed controls are designed to replace obsolete, tapped winding, or reactive methods of speed control. The full-wave phase control circuitry minimizes power loss, thereby reducing energy requirements. The controls provide infinitely variable speed adjustment which allows the end-user to select the desired level of air volume. These models cover a wide range of current ratings (2.5 - 15 Amps AC) and voltage ratings (115, 230, 277 Volts AC).

Important features, such as RFI Filter, Minimum Speed Trimptot, and built-in On/Off Line Switch are standard. These speed controls are available as bulk packaged or in distributor type packaging with accessories such as: knob, dial plate, mounting hardware, instructions, and individual carton. All models are designed to be mounted into a standard 2" X 4" electrical wall box.

APPLICATION NOTES

- Radio Frequency Interference (RFI):** All solid-state speed controls generate annoying radio noise on the AM band. KB speed controls contain, as standard, a high-gain RFI suppression filter which significantly reduces this interference.
- Low End Set Point (Minimum speed):** All 115 Volt input speed controls are factory set to 60 Volts AC output (± 3 Volts), as standard. All 230 Volt input speed controls are factory set to 120 Volts AC output (± 6 Volts), as standard. All controls are factory calibrated using an average responding AC voltmeter. Custom voltage settings are available.
- Motor Suitability:** Motors must be loaded to near full capacity with the appropriate fan blade in order to achieve proper speed control. Generally, motor suitability is established by determining motor speed as a function of applied voltage. A motor is determined as suitable if it changes speed linearly over a wide range of voltage.
It is required that all motors contain a built-in thermal overload protector when used with solid-state speed controls.
- 230 & 277 VAC Controls:** To achieve maximum reliability, all 230 VAC controls contain snubber networks that utilize Y-Type capacitors and flame-proof resistors. In addition, all 277 VAC controls contain MOV Transient Suppression.
- Temperature Test:** The non-sinusoidal output voltage of a solid-state speed control may increase motor heating. Therefore, it is necessary that a temperature test be performed to ensure that the motor is operating within manufacturer's specifications.
- Leads:** All leads are approximately 6" (15 cm) long and stripped 1/2" (1.25 cm). Custom lead lengths, colors, and terminations also available.

ELECTRICAL RATINGS AND AGENCY APPROVALS

Model No.	AC Line Input Voltage (Volts AC – 50/60 Hz)	Maximum Current Rating (Amps RMS)	Ambient Temperature (°C)	Agency Approvals			Package Type
							
KBWC-13	115	2.5	25	✓		✓	B
KBWC-15	115	5	40		✓	✓	C
KBWC-16	115	6	25	✓			C
KBWC-18K ¹	115	8	40		✓	✓	D
KBWC-110K ¹	115	10	25	✓		✓	D
KBWC-110K ¹	115	10	40		✓	✓	E
KBWC-112K ¹	115	12	40				E
KBWC-115K ¹	115	15	25	✓			E
KBWC-23 ²	230	2.5	25	✓			B
KBWC-25 ³	230	5	40	✓			C
KBWC-26	230	6	25				C
KBWC-28K ¹	230	8	40			✓	D
KBWC-210K ¹	230	10	40				E
KBWC-212K ¹	230	12	40				E
KBWC-215K ¹	230	15	25				E
KBWC-35	277	5	25	✓			C
KBWC-36	277	6	25				C
KBWC-38K ¹	277	8	25				D
KBWC-310K ¹	277	10	25				D
KBWC-312K ¹	277	12	25				E
KBWC-315K ¹	277	15	25				E

Notes: 1. Models rated 8 Amps and above include Mounting Kit (suffix "K"). 2. Only model containing suffix "NS" is UL Recognized. 3. Only Model KBWC-25 (4L) is UL Recognized. 4. The maximum Locked Rotor current for UL listed controls is 6 times the Maximum Current Rating.

CONNECTION DIAGRAMS

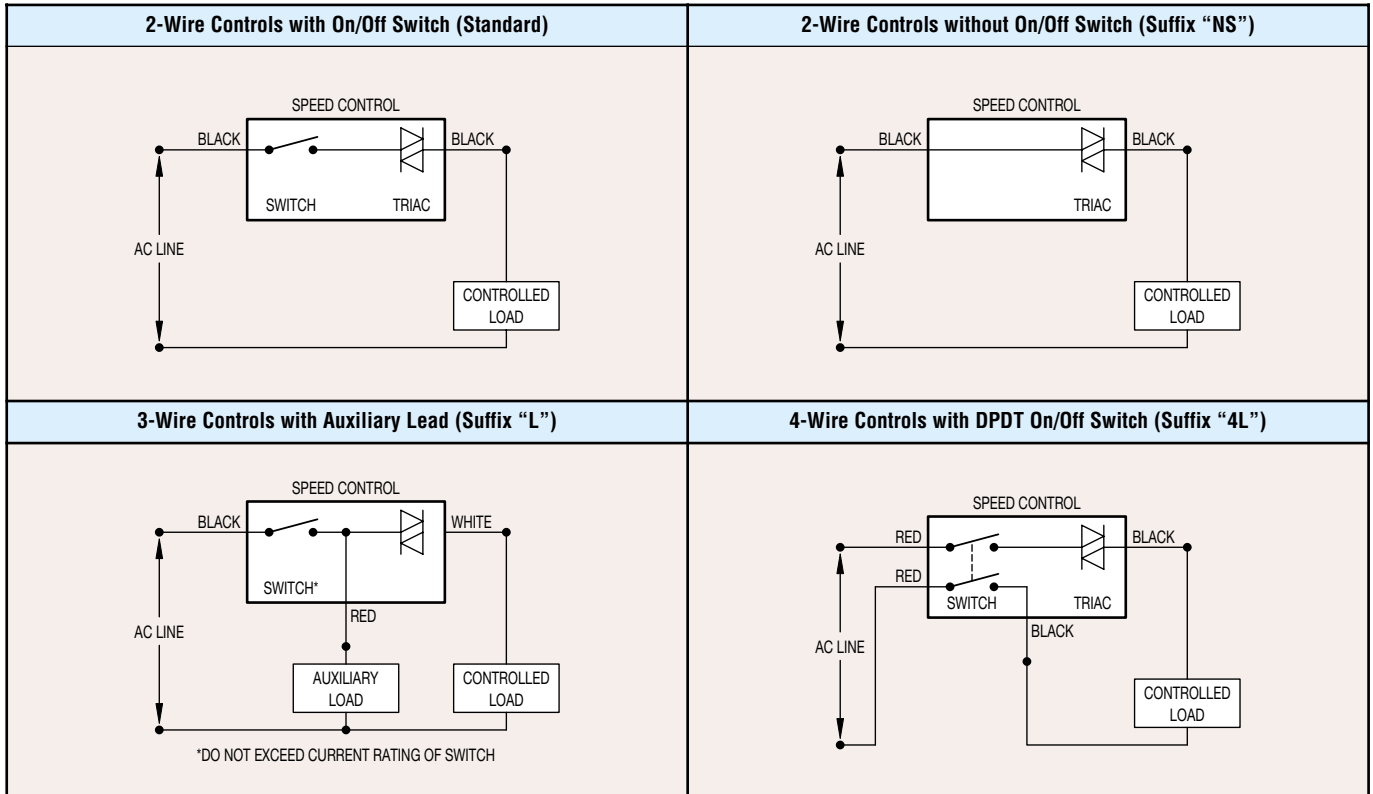

KBWC-13, 23 (Pkg. B)
Mechanical Specifications (Inches/mm)

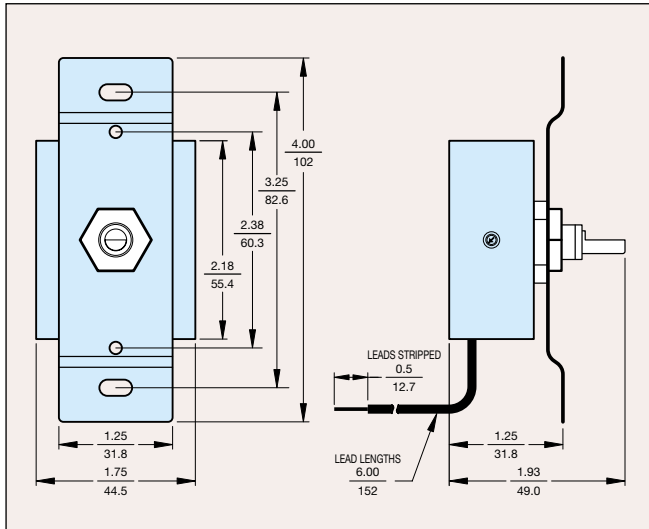

KBWC-15, 16, 25, 26, 35, 36 (Pkg. C)
Mechanical Specifications (Inches/mm)

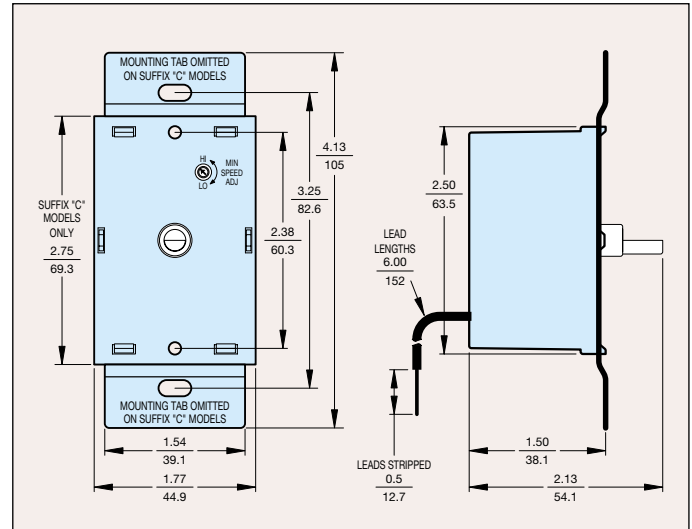

Dial Plate and Knob Kit (Suffix "K")
Mechanical Specifications (Inches/mm)

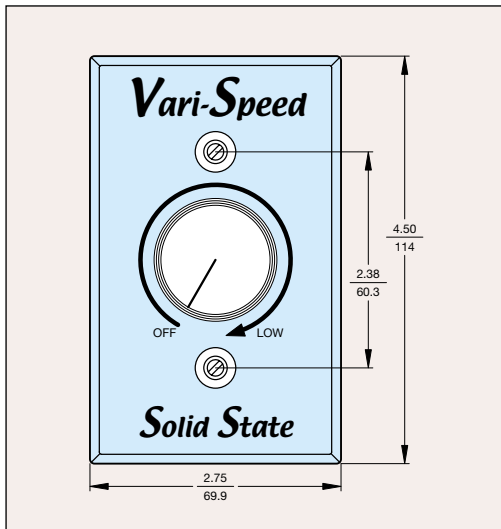

KBWC-18K, 110K, 28K, 38K, 310K (Pkg. D)
Mechanical Specifications (Inches/mm)

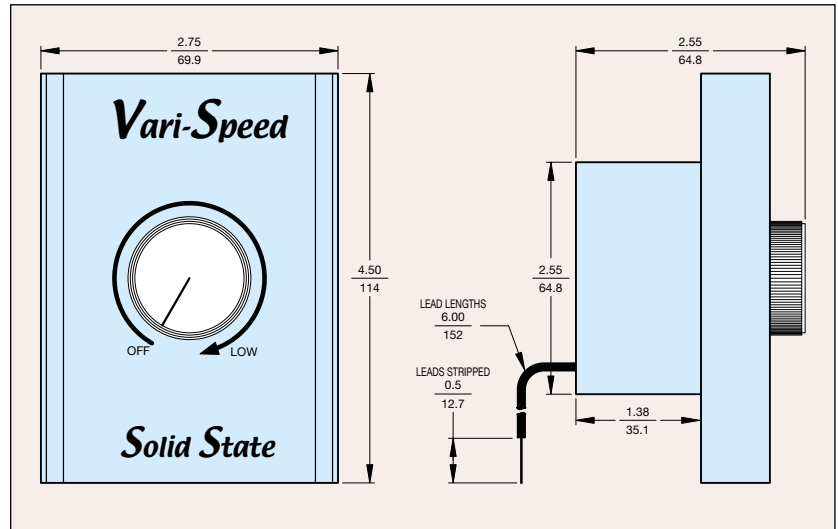

KBWC-110K, 112K, 115K, 210K, 212K, 215K, 312K, 315K, (Pkg. E)
Mechanical Specifications (Inches/mm)

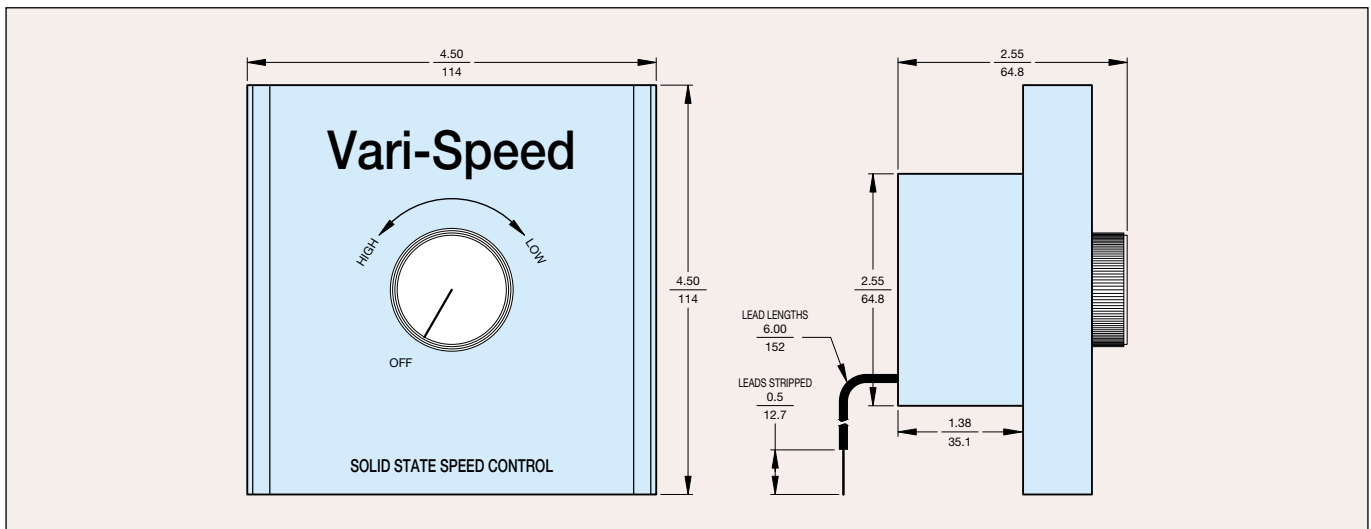

INSTRUCTIONS FOR INSTALLING WALL-MOUNT SPEED CONTROL



Safety Warning! Please Read Carefully

Unit should be installed by a qualified electrician in accordance with the National Electrical Code and other local codes which may apply. This control must be grounded when installed. Failure to follow these instructions may result in electrical shock or a fire hazard. To reduce the risk of fire or electric shock, this control is to be used only with fans marked as suitable for use with solid state speed controls. This control is suitable for mounting in a metal or polymeric field enclosure. These controls must not be used at ratings exceeding those clearly marked on the device.

We are not responsible for any expense, inconvenience or subsequent damage caused by items of our manufacture or sale.

1 Application

- Motor Type – Shaded Pole, P.S.C., and Universal.
- Required Load – Fans, Blowers and speed dependent loads.

2 Wiring

Warning! Power must be turned off before wiring. Connect control in series with motor and line voltage; never connect control across line.

Ground (earth)** – Be sure to ground control using the green wire.

***Some models do not require grounding. Therefore, a ground wire is not provided.*

3 Mounting

- Use 2" deep standard electrical box.
- Secure control with outer bracket tabs.

4 Minimum Speed Adjustment

Important: If this option is not supplied, disregard step 4 and continue to step 5.

This control was designed to operate on motors used in diverse applications. A minimum speed adjustment is provided to allow independent control of the minimum speed setting. Minimum speed adjustment ensures motor runs with sufficient torque to prevent stalling.

- Motor must be in actual operating conditions to achieve proper speed adjustment. Motor will not slow down unless proper load is applied.
- Turn main control knob to lowest speed position.
- Locate and adjust minimum speed setting on front plate with screw driver (rotate clockwise to decrease minimum speed; counter-clockwise to increase minimum speed).

Special Note: For 2.5 and 3.0 Amp models, adjustment of minimum speed is reversed. Rotate clockwise to increase minimum speed; counter-clockwise to decrease minimum speed.

On some models minimum speed adjustment hole is located on side of control.

- Motor will now operate from this preset minimum speed to full speed.

5 Final Mounting

- Install front dial plate (remove protective plastic on face of dial plate).
- Turn main control until switch snaps off. (Switch models only).
- Push on knob so that pointer is in off position.

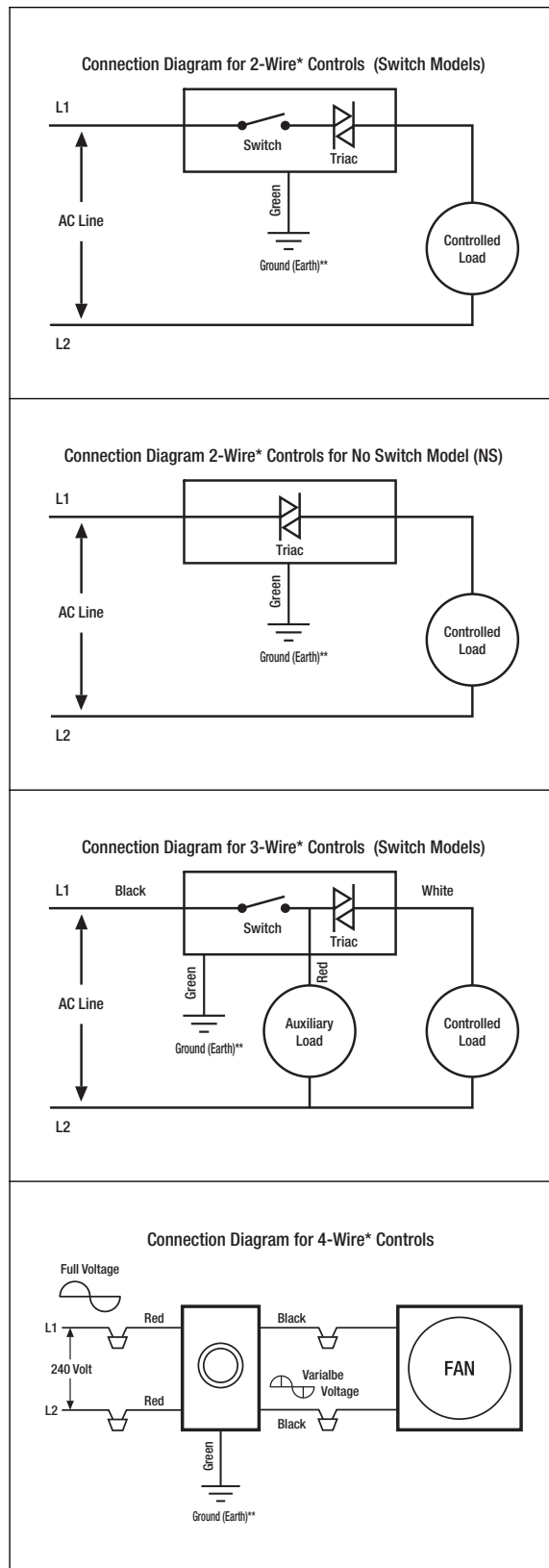

*Ground wire is not counted when designating 2,3 or 4 wire controls.