



Reciprocating Air Compressors

Engine Driven Wheelbarrow SS3, SS5

Owner's Manual with Parts List

- EN** Owner's Manual with Parts List
- FR** Manuel du propriétaire avec liste des pièces
- ES** Manual del propietario con la lista de piezas



Save These Instructions



CONTENTS

CONSUMER INFORMATION SHEET	3	OPERATION	10
INSTALLATION, OPERATION, MAINTENANCE & TROUBLESHOOTING ISSUES	3	GENERAL	10
MISSING PARTS.....	3	NORMAL START-UP	10
SHIPPING DAMAGE OR DEFECTIVE PARTS.....	3	START-UP.....	10
ABOUT THIS MANUAL	4	SHUT-DOWN	10
SAFETY INFORMATION	4	MAINTENANCE	11
EXPLANATION OF SAFETY SIGNAL WORDS.....	4	FILTER REPLACEMENT (SS3).....	11
GENERAL SAFETY PRECAUTIONS	4	FILTER REPLACEMENT (SS5).....	11
ADDITIONAL GENERAL SAFETY PRECAUTIONS.....	5	COMPRESSOR PUMP OIL CHANGE	12
GENERAL INFORMATION	5	BELT ADJUSTMENT	12
INSTALLATION	6	CHECKING BELT TENSION.....	12
SELECTING A LOCATION	6	TENSIONING BELTS.....	12
GENERAL	6	TANK INSPECTION	12
TEMPERATURE.....	6	TROUBLESHOOTING	13
HUMID AREAS	6	SS3 - BARE COMPRESSOR PUMP ASSEMBLY	14
NOISE CONSIDERATIONS	6	MODEL SS3 BARE COMPRESSOR PUMP	14
INSTALLING THE ISOLATOR PADS	6	SS3 - COMPRESSOR PARTS LIST	16
INSTALLING THE INLET AIR FILTER.....	6	SS5 - BARE COMPRESSOR PUMP ASSEMBLY	18
INSTALLING DISCHARGE PIPING	6	MODEL SS5 BARE COMPRESSOR PUMP	18
SYNTHETIC COMPRESSOR LUBRICANT MATERIAL COMPATIBILITY LIST	7	SS5 - COMPRESSOR PARTS LIST	20
GENERAL REQUIREMENTS	7	SS5 - COMPRESSOR WHEEL ASSEMBLY PARTS LIST	22
CONDENSATE DISCHARGE PIPING	7	KITS & ACCESSORIES	23
COMPRESSOR LUBRICATION.....	7	START-UP KIT	23
SYNTHETIC COMPRESSOR LUBRICANT	7	INGERSOLL-RAND SYNTHETIC COMPRESSOR LUBRICANT.....	23
ALTERNATE LUBRICANTS.....	7	AIR FILTER ELEMENT	23
GASOLINE ENGINE COMPRESSORS.....	8	STEP SAVER KITS.....	23
CONNECTION PROCEDURES:.....	8	CRANKCASE HEATER KIT	23
WHEN TRANSPORTING THE COMPRESSOR - FOR GASOLINE ENGINE UNITS.....	9	MULTI-PURPOSE AIR HOSES	23
COMPRESSOR CONTROLS (GASOLINE ENGINE COMPRESSORS)	9	ENGINE PARTS.....	23
COMPRESSOR PUMP FILLING PROCEDURES.....	9	WARRANTY AND LIMITATION OF LIABILITY	24
ENGINE LUBRICATION AND FUEL.....	9	WARRANTY.....	24
		LIMITATION OF LIABILITY	24

CONSUMER INFORMATION SHEET

Thank you for purchasing an **Ingersoll Rand** product. We trust that it will offer you many years of trouble-free service. If you encounter any problems or need assistance, please refer to the information provided in this sheet.

■ INSTALLATION, OPERATION, MAINTENANCE & TROUBLESHOOTING ISSUES

Read the owner's manual first. Often this will clarify your understanding. If you still have problems, please call the toll-free hotline.

■ MISSING PARTS

If parts are missing call the toll-free hotline. Have the serial number, part number, model number and parts list (with missing parts circled) handy when you call. Your parts will be shipped immediately.

■ SHIPPING DAMAGE OR DEFECTIVE PARTS

Each new product is inspected and in good condition prior to shipment from the factory. If your product was received in a condition that was less than satisfactory, or if you discover a defect that require service or adjustment by qualified personnel, please contact your nearest authorized service representative.

DO NOT RETURN THE PRODUCT TO YOUR RETAILER!

PARTS & SERVICE HOTLINE:**1-800-AIR-SERV****(1-800-247-7378)**

ABOUT THIS MANUAL

This manual provides safe and reliable instructions for the installation, operation and maintenance of your **Ingersoll Rand** air compressor. Carefully read this manual before attempting to operate or perform any maintenance. If you are uncertain about any of the instructions or procedures provided in this manual, contact **Ingersoll Rand**. We recommend you retain this manual, and all publications provided with your air compressor, in a location which is accessible to all personnel who operate and service your compressed air equipment.

SAFETY INFORMATION

■ EXPLANATION OF SAFETY SIGNAL WORDS

Throughout this manual there are steps and procedures which, if not followed, may result in a hazard. The following signal words are used to identify the level of potential hazard.

DANGER

Indicates an imminently hazardous situation which, if not avoided, will result in death or serious injury.

WARNING

Indicates a potentially hazardous situation which, if not avoided, could result in death or serious injury.

CAUTION

Indicates a potentially hazardous situation which, if not avoided, may result in minor or moderate injury or property damage.

NOTICE

Indicates information or a company policy that relates directly or indirectly to the safety of personnel or protection of property.

■ GENERAL SAFETY PRECAUTIONS

DANGER

INTAKE AIR

Can contain carbon monoxide or other contaminants. Will cause serious injury or death. Ingersoll Rand air compressors are not designed, intended or approved for breathing air. Compressed air should not be used for breathing air applications unless treated in accordance with all applicable codes and regulations.

WARNING

HAZARDOUS VOLTAGE

Can cause serious injury or death. Disconnect power and bleed pressure from the tank before servicing. Lockout/Tagout machine. Compressor must be connected to properly grounded circuit. See grounding instructions in manual. Do not operate compressor in wet conditions. Store indoors.

WARNING

MOVING PARTS

Can cause serious injury. Do not operate with guards removed. Machine may start automatically. Disconnect power before servicing. Lockout/Tagout machine.

WARNING

HOT SURFACES.

Can cause serious injury. Do not touch. Allow to cool before servicing. Do not touch hot compressor or tubing.

WARNING

HIGH PRESSURE AIR.

Bypassing, modifying or removing safety/relief valves can cause serious injury or death. Do not bypass, modify or remove safety/relief valves. Do not direct air stream at body. Rusted tanks can cause explosion and severe injury or death. Drain tank daily or after each use. Drain valve located at bottom of tank.

CAUTION

RISK OF BURSTING

Use only suitable air handling parts acceptable for pressure of not less than the maximum allowable working pressure of the machine

SAFETY INFORMATION

■ ADDITIONAL GENERAL SAFETY PRECAUTIONS

- Compressor must be operated in well-ventilated area.
- Do not directly inhale compressed air.
- Do not over pressurize the receiver tank or similar vessel beyond design limits.
- Do not use a receiver tank or similar vessels that fail to meet the design requirements of the compressor. For additional information contact the **Ingersoll Rand** factory or the nearest service provider.
- Do not drill into, weld or otherwise alter the receiver tank or similar vessels.
- Do not remove, adjust, bypass, change, modify or make substitutions for safety/relief valves or other pressure control related devices.
- Do not use air tools or attachments without first determining the maximum pressure recommended for that equipment.
- Do not point air nozzles toward anyone.
- Do not touch the compressor pump, engine or discharge tubing during or shortly after operation. These parts become hot.
- Wear eye protection when operating or servicing compressor.
- Do not operate where flammable or explosive liquids or vapors such as gasoline, natural gas and solvents are present.
- Do not operate with guards or shields removed, damaged or broken.
- Do not remove, paint over or deface decals. Replace any missing decals.

GENERAL INFORMATION

The air compressor unit is suitable for operating a variety of air tools. Depending on your application, the following accessories may be required:

- An air line filter for removal of moisture and oil vapor in compressed air.
- An in-line lubricator to prolong the life of air tools.

- Separate air transformers which combine the functions of air regulation and/or moisture and dirt removal.

Contact your nearest authorized dealer for more information on air tools and accessories for your application.

INSTALLATION

■ SELECTING A LOCATION

■ GENERAL

Select a clean, dry, well-lighted area with plenty of ventilation proper cooling air flow and accessibility. Locate the unit at least 12 inches (30 cm) from walls. Ensure that the unit is as level as possible to avoid fuel spillage.

■ TEMPERATURE

Ideal operating temperatures are between 40 °F to 100 °F (4 °C to 37.8 °C). In lower temperatures, you must protect safety/relief valves and drain valves from freezing.

■ HUMID AREAS

In frequently humid areas, moisture may form in the bare pump and produce sludge in the lubricant, causing running parts to wear out prematurely. Excessive moisture is especially likely to occur if the unit is located in an unheated area that is subjected to large temperature changes. Two signs of excessive humidity are external condensation on the bare pump when it cools down and a “milky” appearance in petroleum compressor lubricant. You may be able to prevent moisture from forming in the bare pump by increasing ventilation or operating for longer intervals.

■ NOISE CONSIDERATIONS

Consult local officials for information regarding acceptable noise levels in your area. To reduce excessive noise, use vibration mounts or intake silencers, relocate the unit or construct total enclosure or baffle walls. Consult your dealer for assistance.

■ INSTALLING THE ISOLATOR PADS

1. Install isolator pads (A) on all four feet with self-tap screws (B).
2. Hand tighten screws.

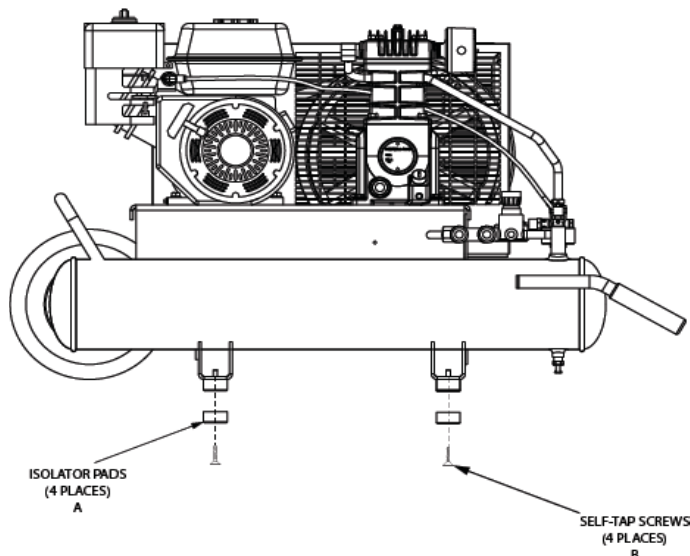

■ INSTALLING THE INLET AIR FILTER

⚠ CAUTION

Do not operate without air inlet filter.

Install the air inlet filter at the inlet connection at the bare pump. If heavy duty filtration is required, contact your dealer for information.

■ INSTALLING DISCHARGE PIPING

If it is necessary to install air discharge piping or condensate discharge piping, adhere to the following general guidelines. Contact your dealer for more information.

⚠ WARNING

Do not use plastic pipe, rubber hose or lead-tin soldered joints anywhere in the compressed air system.

⚠ WARNING

If an after-cooler, check valve, block valve, or any other restriction is added to the compressor discharge, install a properly-sized ASME approved safety/relief valve between the compressor discharge and the restriction.

⚠ CAUTION

If you will be using Ingersoll Rand Synthetic Lubricant all downstream piping material and system components must be compatible. Refer to the following compatibility list. If there are incompatible materials present in your system, or there are materials not included in the list, contact your dealer.

INSTALLATION

■ SYNTHETIC COMPRESSOR LUBRICANT MATERIAL COMPATIBILITY LIST

SUITABLE	NOT RECOMMENDED
• Viton®	• Neoprene
• Teflon®	• Natural Rubber
• Epoxy (Glass Filled)	• SBR Rubber
• Oil Resistant Alkyd	• Acrylic Paint
• Fluorosilicone	• Lacquer
• Fluorocarbon	• Varnish
• Polysulfide	• Polystyrene
• 2-Component Urethane	• PVC
• Nylon	• ABS
• Delrin®	• Polycarbonate
• Celcon®	• Cellulose Acetate
• High Nitrile Rubber (Buna N. NBR more than 36% Acrylonitrile)	• Low Nitrile Rubber (Buna N. NBR less than 36% Acrylonitrile)
• Polyurethane	• EPDM
• Polyethylene	• Ethylene Vinyl Acetate
• Epichlorohydrin	• Latex
• Polyacrylate	• EPR
• Melamine	• Acrylics
• Polypropylene	• Phenoxy
• Baked Phenolics	• Polysulfones
• Epoxy	• Styrene Acrylonitrile (San)
• Modified Alkyds (® indicates trademark of DuPont Corporation).	• Butyl.

■ GENERAL REQUIREMENTS

The piping, fittings, air receiver tank, etc. must be certified safe for at least the maximum working pressure of the unit. Use hard-welded or threaded steel or copper pipes and cast iron fittings and hoses that are certified safe for the unit's discharge pressure and temperature. **DO NOT USE PVC PLASTIC.** Use pipe thread sealant on all threads, and make up joints tightly to prevent air leaks.

■ CONDENSATE DISCHARGE PIPING

If installing a condensate discharge line, the piping must be at least one size larger than the connection, as short and direct as possible, secured tightly and routed to a suitable drain point or waste container. Condensate must be disposed of in accordance with local, state, and federal laws and regulations.

NOTICE

All compressed air systems generate condensate which accumulates in any drain point (e.g. tanks, filters, drip legs, after-coolers, dryers). This condensate contains lubricating oil and/or substances which may be regulated and must be disposed of in accordance with local, state, and federal laws and regulations.

■ COMPRESSOR LUBRICATION



CAUTION

Do not operate without lubricant or with inadequate lubricant. Ingersoll Rand is not responsible for compressor failure caused by inadequate lubrication.

■ SYNTHETIC COMPRESSOR LUBRICANT

Ingersoll Rand recommends All Season Select synthetic lubricant from start-up. See the WARRANTY section for extended warranty information.

■ ALTERNATE LUBRICANTS

You may use XL-300 or a comparable petroleum-based lubricant that is premium quality, does not contain detergents, contains only anti-rust, anti-oxidation, and anti-foam agents as additives, has a flashpoint of 440°F (227°C) or higher, and has an auto-ignition point of 650°F (343°C) or higher

See the petroleum lubricant viscosity table below. The table is intended as a general guide only. Heavy duty operating conditions require heavier viscosities. Refer specific operating conditions to **Ingersoll Rand** for recommendations.

INSTALLATION

Temperature Around Compressor		Viscosity @ 100°F (37.8°C)		Viscosity Grade	
°F	°C	SUS	Centistokes	ISO	SAE
< 40	< 4.4	150	32	32	10
40-80	4.4-26.7	500	110	100	30
80-125	26.7-51.0	750	165	150	40

If you use a petroleum-based compressor lubricant at start-up and decide to convert to All Season Select later on, the pump must be decarbonized and flushed before conversion. Contact **Ingersoll Rand** for more information.

■ **GASOLINE ENGINE COMPRESSORS**

NOTICE

If you will be making connections to a remote battery, the engine on the compressor must be equipped with an alternator.

BATTERY. A 12 volt battery with a minimum current rating of 275 CCA (cold cranking amps) and minimum ampere-hour rating of 24 Ah should be sufficient for cranking most electric start engines.

BATTERY CABLES. Refer to the following table for size and length recommendations.

Cable Size (GA)	Maximum Length
6	5' (1.5 m.)
4	7'-2.5" (2.1 m.)
2	12' (3.6 m.)

■ **CONNECTION PROCEDURES:**

1. Connect the battery positive (+) cable (A) to the starter solenoid terminal (B).

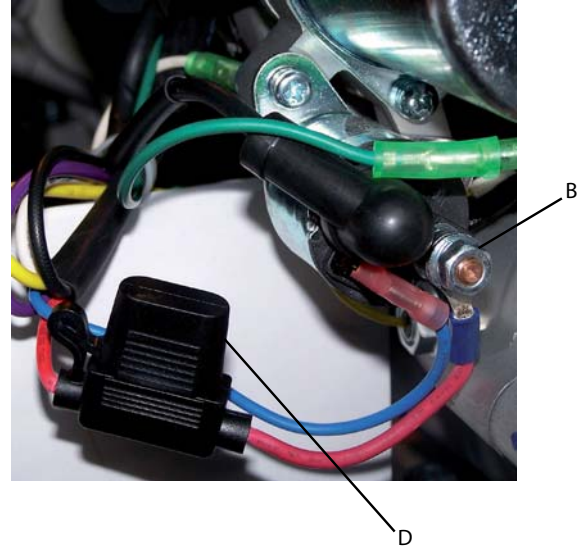
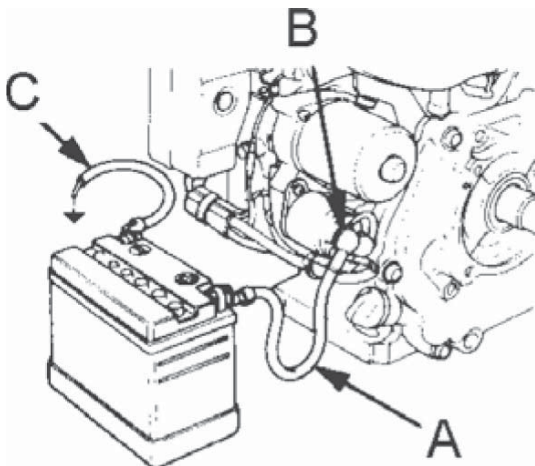

Kohler Engine Battery (+) Positive cable connection point

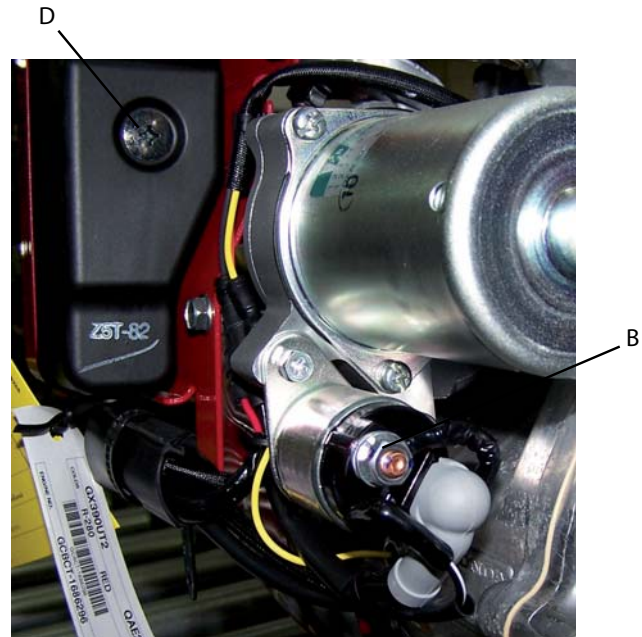

Honda Engine Battery (+) Positive cable connection point

NOTE: Circuit Fuse location at (D). Electric Start will not work if Fuse is blown. Unit can be rope started, however will not charge battery if Fuse is blown.

INSTALLATION

- Connect the battery negative (-) cable (C) to the bolt shown in the following illustration. Secure the wire in place by screwing a suitably-sized nut onto the bolt and down onto the terminal.

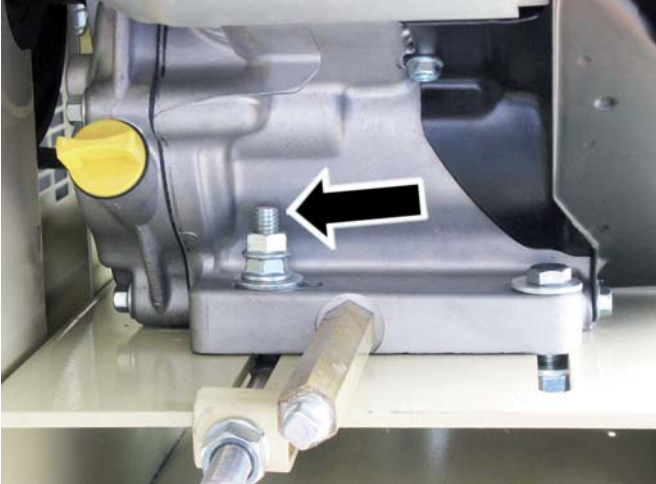

- Connect the battery positive (+) cable (A) to the battery positive (+) terminal.
- Connect the battery negative (-) cable (C) to the battery negative (-) terminal.
- Coat the terminals and cable ends with corrosion-preventive grease.

WARNING

Remove the cable from the negative (-) side of the battery before servicing..

Refer to the engine manufacturer's instructions for more information.

■ WHEN TRANSPORTING THE COMPRESSOR - FOR GASOLINE ENGINE UNITS

CAUTION

When transporting the compressor, shut off the Engine and turn the fuel shut off valve to the off position. See Figure below.

If the compressor is permanently mounted on a vehicle, shut off the Engine and turn the fuel shut off valve to the off position when the unit is not in use. See Figure below.

Gasoline Shut Off Valve (Shown in off position)



■ COMPRESSOR CONTROLS (GASOLINE ENGINE COMPRESSORS)

CONSTANT SPEED CONTROL. This type of control applies to gasoline engine compressors.

When the receiver tank pressure reaches the factory preset maximum pressure, the unloader slows down the engine and the compressor stops pumping. When the receiver tank pressure drops to the factory preset minimum, the unloader resets, the engine returns to full speed, and the compressor resumes pumping.

■ COMPRESSOR PUMP FILLING PROCEDURES

- Unscrew and remove the oil fill plug (A).
- Slowly fill the crankcase with lubricant until the lubricant reaches the top thread of the oil fill opening and the top of the sight glass.
Note: SS3 Crankcase capacity is one (1) pint (0.5 liters)
Note: SS5 Crankcase capacity is one (2.1) pints (1 liters)
- Replace the oil fill plug **HAND TIGHT ONLY**.

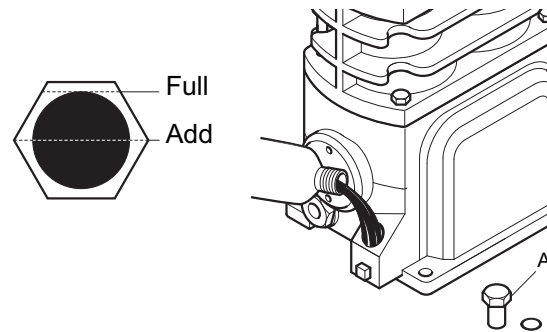

■ ENGINE LUBRICATION AND FUEL

CAUTION

Do not operate without lubricant or with inadequate lubricant. Ingersoll Rand is not responsible for engine failure caused by inadequate lubrication.

Refer to the engine operator's manual provided with the unit for engine lubrication and fuel requirements.

OPERATION

■ GENERAL

The air compressor is designed for 100% continuous duty operation with the use of **Ingersoll Rand** synthetic lubricant and 60% continuous duty operation with the use of petroleum lubricant. In other words, synthetic lubricant allows the compressor to pump continuously without cycling. Petroleum lubricant limits the compressor to a maximum of 36 minutes of pumping time per hour. The compressor should not cycle more than 10 times per hour.

■ NORMAL START-UP

■ START-UP

1. Turn regulator adjusting knob counter-clockwise until fully closed.
2. Attach hose and accessory.
3. This compressor package is equipped with a new automatic unloader valve assy eliminating the need to manually toggle the valve for engine starting. In addition, the automatic unloader has a "Cold Start" feature shown in the illustration below. This valve bleeds air from the compressor discharge airstream during engine starting, reducing engine starting torque requirements. These valves are especially helpful on oil-lubed compressor pumps that may be subject to low temperatures. When the discharge line is at zero pressure, the Cold Start valve is open. As the engine starts, air flows out of the Cold Start bleed hole into the atmosphere; as discharge pressure increases, the bleed hole closes and stays closed until the end of the pump-up cycle. During normal operation a negligible air flow may be felt at the Cold Start bleed hole. This is not cause for concern.



4. Follow instructions in engine owner's manual for starting and running engine.
5. Using the tank pressure gauge for reference, allow tank pressure to build to maximum pressure.

NOTICE

When the tank reaches cut-out pressure, the compressor stops pumping but the engine continues to run. When the receiver tank pressure drops below the factory pre-set minimum, the compressor resumes pumping and the tank builds to cut-out pressure.

6. Turn regulator adjusting knob clockwise to obtain desired pressure, indicated by the gauge mounted on the regulator.

■ SHUT-DOWN

1. Follow instructions in engine owner's manual for shutting off engine.
2. Turn regulator adjusting knob counter-clockwise until fully closed.
3. Remove accessory.
4. Turn regulator adjusting knob clockwise slowly to allow air to escape from tank. When the tank pressure gauge indicates 20 psig, turn regulator adjusting knob counter-clockwise until fully closed.
5. Open manual drain valve slowly to drain moisture from tank and bleed remaining air.
6. Close manual drain valve.
7. Turn fuel shut-off valve to "off" position before transporting unit.

⚠ CAUTION

Unusual noise or vibration indicates a problem. Do not continue to operate until you identify and correct the source of the problem. IF EMERGENCY CONDITIONS ARE ENCOUNTERED, SHUT-OFF THE MAIN POWER IMMEDIATELY.

MAINTENANCE

⚠ WARNING

Disconnect wire from engine spark plug and release air pressure from the tank before performing maintenance.

NOTICE

All compressed air systems contain maintenance parts (e.g. lubricating oil, filters, separators) which are periodically replaced. These used parts may be, or may contain, substances that are regulated and must be disposed of in accordance with local, state, and federal laws and regulations.

NOTICE

Take note of the positions and locations of parts during disassembly to make reassembly easier. The assembly sequences and parts illustrated may differ for your particular unit.

NOTICE

Follow engine owner's manual for engine maintenance schedules and procedures.

NOTICE

Any service operations not included in this section should be performed by an authorized service representatives.

PERIOD	MAINTENANCE
Daily or before each operation	Check lubricant level. Fill as needed.
	Drain receiver tank condensate. Open the manual drain valve and collect, dispose condensate accordingly.
	Check for unusual noise and vibration.
	Ensure beltguards and covers are securely placed.
Weekly/ Monthly	Ensure area around compressor is free from rags, tools, debris, and flammable or explosive materials.
	Inspect air filter element. Clean/Replace if necessary.
	Inspect for air leaks. Squirt soapy water around joints during compressor operation and watch for bubbles.
3/500* 12/2000*	Check tightness of screws and bolts. Tighten as needed.
	Clean exterior.
	Change petroleum lubricant while crankcase is warm.
	Change synthetic lubricant while crankcase is warm.
	Replace filter element.

* - indicates months/operating hours, whichever occurs first

■ FILTER REPLACEMENT (SS3)

1. Unscrew and remove the wing-nut (A).
2. Remove the filter cover (B), baffle (C) and element (D) from the base (E).
3. Install a new element and reassemble the filter assembly.

NOTICE

The air intake holes in the baffle and cover must be staggered 180°. When reinstalling the assembly at the inlet connection, ensure the intake hole in the cover is on the bottom to minimize the entry of foreign matter from the air.

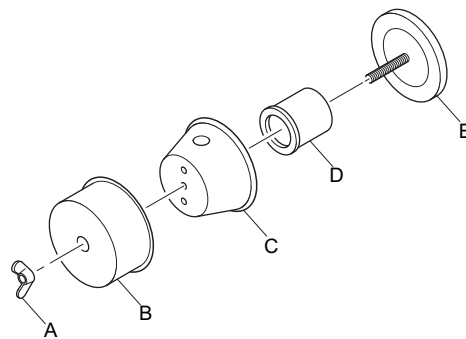

■ FILTER REPLACEMENT (SS5)

1. Unscrew and remove the wing nut (A) securing the filter housing (B) to its base (C).
2. Remove the filter housing and withdraw the old filter element (D). Clean the element with a jet of air or vacuum.
3. Replace the filter element and housing, securing it in place with the wing nut previously removed.

NOTICE

The air intake holes in the baffle and cover must be staggered 180°. When reinstalling the assembly at the inlet connection, ensure the intake hole in the cover is on the bottom to minimize the entry of foreign matter from the air.

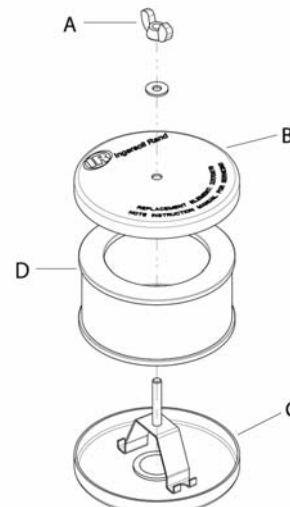

MAINTENANCE

■ COMPRESSOR PUMP OIL CHANGE

1. Remove the oil drain plug (A) and allow the lubricant to drain into a suitable container.
2. Replace the oil drain plug.
3. Follow the filling procedures in OPERATION section.

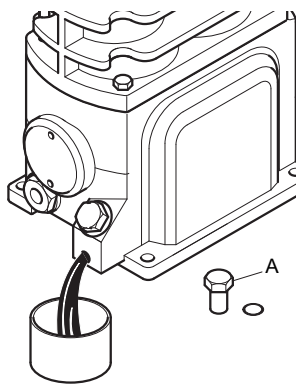

■ BELT ADJUSTMENT

■ CHECKING BELT TENSION.

Check belt tension occasionally, especially if looseness is suspected. New belts must also be properly tensioned upon installation.

A quick check to determine if adjustment is proper may be made by observing the slack side of the belt for a slight bow when the unit is in operation. If a slight bow is evident, the belt is usually adjusted satisfactorily.

■ TENSIONING BELTS.

Belt tensioning can be achieved by loosening the motor or engine anchor screws, pushing the motor or engine away from the pump, and retightening the motor or engine anchor screws. Some units are equipped with a belt tensioning bolt that, when turned, pulls the motor or engine away from the pump. Otherwise, the motor can be easily moved by placing a prying tool beneath it. A commercially available spreader or other belt tensioning device can also be helpful.

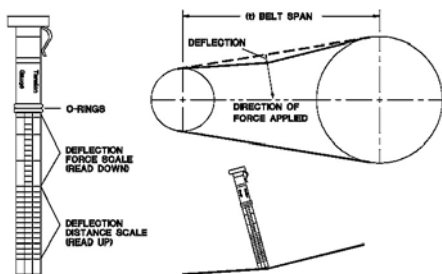

Follow the procedures outlined below to correctly set and measure belt tension.

1. Lay a straight edge across the top outer surface of the belt drive from pulley to sheave.

2. At the center of the span, perpendicular to the belt, apply pressure to the outer surface of the belt with a tension gauge. Force the belt to the deflection indicated in the table below. Compare the reading on the tension gauge to the table.

Model	Deflection In Inches	Min. Tension (Lbs.) (Used)	Max. Tension (Lbs.) (New)
SS5	0.2	4.2	6.2
SS3	0.17	3.0	6.0

Ensure the pulley and sheave are properly aligned and the motor anchor screws are adequately retightened prior to restarting the compressor.

⚠ CAUTION

Improper pulley/sheave alignment and belt tension can result in motor overload, excessive vibration, and premature belt and/or bearing failure.

To prevent these problems from occurring, ensure the pulley and sheave are aligned and belt tension is satisfactory after installing new belts or tensioning existing belts.

■ TANK INSPECTION

The life of an air receiver tank is dependent upon several factors including, but not limited to, operating conditions, ambient environments, and the level of maintenance. The exact effect of these factors on tank life is difficult to predict; therefore, Ingersoll Rand recommends that you schedule a certified tank inspection within the first five years of compressor service. To arrange a tank inspection, contact the nearest IR Air Center or distributor, or call 1-800-AIR SERV.

If the tank has not been inspected within the first 10 years of compressor service, the receiver must be taken out of service until it has passed inspection. Tanks that fail to meet requirements must be replaced.

⚠ WARNING

Failure to replace a rusted air receiver tank could result in air receiver tank rupture or explosion, which could cause substantial property damage, severe personal injury, or death. Never modify or repair tank. Obtain replacement from service center.

TROUBLESHOOTING

This section provides a list of the more frequently encountered malfunctions, their causes and corrective actions. Some corrective actions can be performed by the operator or maintenance personnel, and others may require the assistance of a qualified **Ingersoll Rand** technician or your dealer.

NOTICE

Please see engine owner's manual for additional engine troubleshooting.

PROBLEM	CHECK POINT	PROBLEM	CHECK POINT
Abnormal piston, ring or cylinder wear	4, 7, 8, 14, 19, 26	High oil consumption	1, 4, 8, 13, 14, 15, 17, 22
Air delivery drops	1, 5, 6, 11, 13, 14, 20	Knocking or rattling	2, 11, 12, 14, 15, 16
Unit does not come up to speed	2, 6, 11, 16	Moisture in crankcase or "milky" appearance in petroleum lubricant or rusting in cylinders	8, 9
Unit is slow to come up to speed	6, 18, 21	Oil in discharge air (oil pumping)	4, 8, 13, 14, 22, 23
Unit runs excessively hot	3, 10, 11	Oil leakage from shaft seal	17
Excessive noise during operation	2, 6, 7, 11, 12, 16, 18	Safety/relief valve "pops"	1, 11, 20
Excessive starting and stopping	5, 18, 23		

CHECK POINTS	POSSIBLE CAUSE	POSSIBLE SOLUTION
1	Clogged or dirty inlet and/or discharge line filter.	Clean or replace.
2	Loose belt wheel or engine pulley, excessive end play in engine shaft or loose drive belts.	Check belt wheel, engine pulley, crankshaft, drive belt tension and alignment. Repair or replace as required.
3	Inadequate ventilation around beltwheel.	Relocate unit for better air flow.
4	Lubricant viscosity too low.	Drain existing lubricant and refill with proper lubricant.
5	Air leaks in air discharge piping.	Check tubing and connections.
6	Lubricant viscosity too high.	Drain existing lubricant and refill with proper lubricant.
7	Lubricant level too low	Add lubricant to crankcase to proper level.
8	Detergent type lubricant being used.	Drain existing lubricant and refill with proper lubricant.
9	Extremely light duty cycles. Unit located in damp or humid location.	Run unit for longer duty cycles. Relocate unit.
10	Drive belts too tight or misaligned.	Adjust belts to proper tension and alignment.
11	Compressor valves leaky, broken, carbonized or loose.	Inspect valves. Clean or replace as required.
12	Carbon build-up on top of piston(s).	Clean piston(s). Repair or replace as required.
13	Piston rings damaged or worn (broken, rough or snached). Excessive end gap or side clearance. Piston rings not seated, are struck in grooves or end gaps not staggered.	Adjust piston rings.
14	Cylinder(s) or piston(s) scratched, worn or scored.	Repair or replace as required.
15	Connecting rod, piston pin or crank pin bearings worn or scored.	Inspect all. Repair or replace as required.
16	Defective ball bearing on crankshaft or motor shaft.	Inspect bearings and replace crankshaft assembly if required.
17	Crankshaft seal worn or crankshaft scored.	Replace seal or crankshaft assembly.
18	Leaking check valve or check valve seat blown down.	Replace check valve.
19	Extremely dusty atmosphere.	Install remote air inlet piping and route to source of cleaner air. Install more effective filtration.
20	Defective safety/relief valve.	Replace safety/relief valve.
21	Ambient temperature too low.	Replace to warmer environment. Convert to synthetic lubricant.
22	Worn cylinder finish.	Deglaze cylinder with 180 grit flex-hone.
23	Excessive condensate in receiver tank.	Drain receiver tank with manual drain valve.

SS3 - BARE COMPRESSOR PUMP ASSEMBLY

■ MODEL SS3 BARE COMPRESSOR PUMP

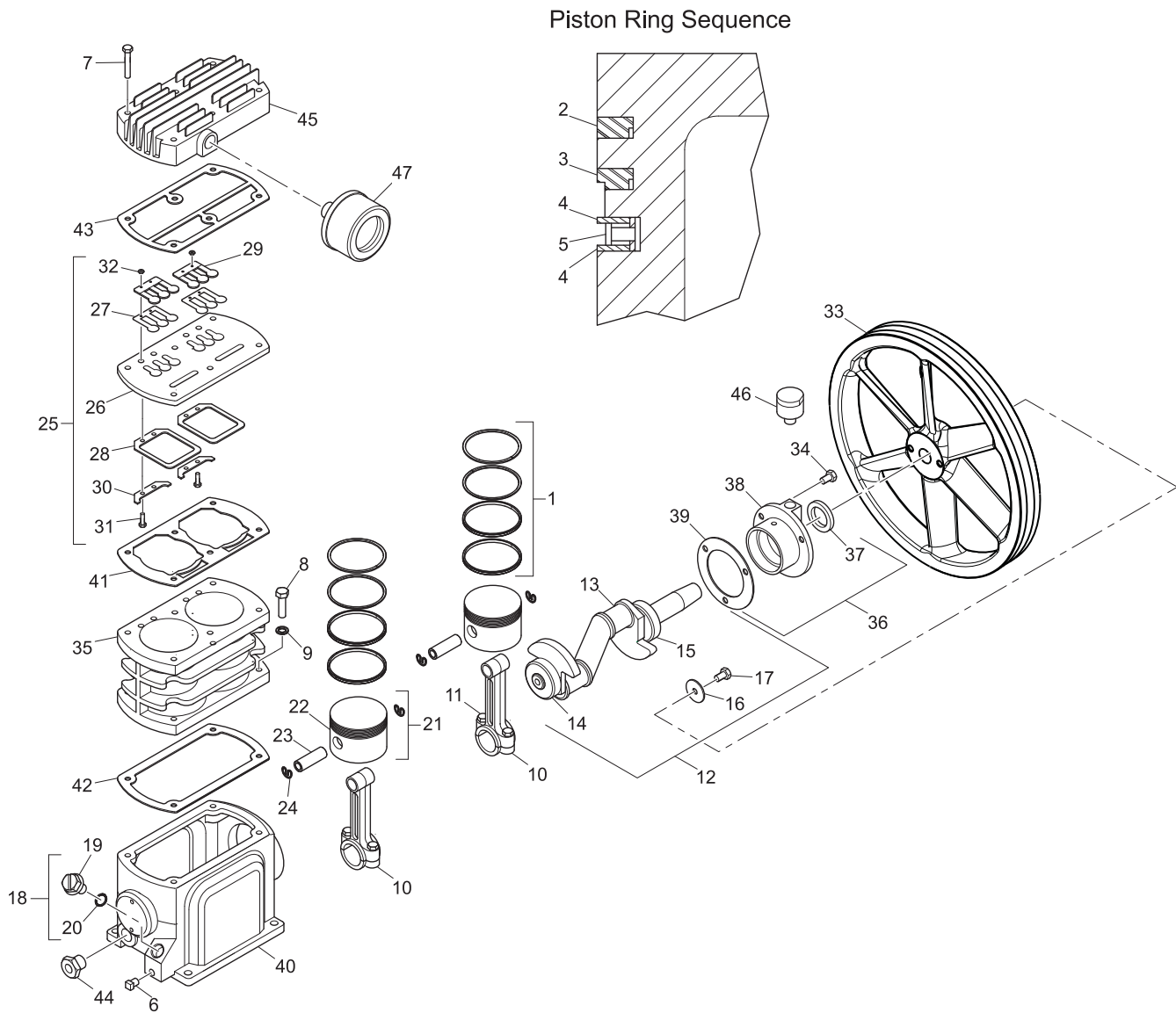

NOTE:

Item 12 includes Item 13, 14, 15, 16 and 17

Item 18 includes of Item 19 and 20

Item 21 includes of Item 22, 23 and 24

Item 25 includes of Item 26, 27, 28, 29, 30, 31 and 32

Item 36 includes of Item 37, 38 and 39

SS3 - BARE COMPRESSOR PUMP ASSEMBLY

Item	CCN	DESCRIPTION	Qty.
REF.	97330419	PUMP, BARE COMPRESSOR	-
1†	32307092	SET, PISTON RING	2
2	NSS	• RING COMPRESSOR	2
3	NSS	• RING SPACER	2
4	NSS	• RING, OIL CONTROL SPACER	4
5	NSS	• RING, OIL CONTROL	2
6	95033585	PLUG, OIL DRAIN	1
7	96715784	CAPSCREW (HEAD BOLT)	6
8	96716113	CAPSCREW	4
9	96728316	WASHER, SPRING	4
10	97330427	ASSEMBLY, CONNECTING ROD	2
11	96702246	• CAPSCREW	4
12	97338081	ASSEMBLY, CRANKSHAFT-SERVICE	1
13	NSS	• CRANKSHAFT	1
14	NSS	• BEARING, MAIN	1
15	NSS	• BEARING, BALL	1
16	54375977	• WASHER	1
17	54440045	• CAPSCREW, LEFT HAND THREAD	1
18	49812050	ASSEMBLY, OIL FILL PLUG	1
19	NSS	• PLUG, OIL FILL	1
20	95024394	• O-RING, OIL FILL PLUG	1
21	97330468	ASSEMBLY, PISTON & PIN	2
22	NSS	• PISTON	1
23	NSS	• PIN, PISTON	1
24	NSS	• RING, LOCK	2
25**	97330484	ASSEMBLY, VALVE	1
26	NSS	• PLATE, VALVE	1

Item	CCN	DESCRIPTION	Qty.
27	NSS	• VALVE, DISCHARGE	2
28	NSS	• VALVE, INLET	2
29	NSS	• STOP, DISCHARGE	2
30	NSS	• RETAINER, INLET	2
31	NSS	• SCREW, HEX HEAD	4
32	NSS	• NUT	4
33	24655631	BELT WHEEL	1
34	97330500	CAPSCREW	3
35	97330625	CYLINDER	1
36	97338073	ASSEMBLY, END COVER-SERVICE	1
37	32204521	• SEAL, SHAFT	1
38	NSS	• COVER, END	1
39	97331227	• GASKET, END COVER	1
40	97330641	FRAME, COMPRESSOR	1
41**	97330658	GASKET, VALVE PLATE	1
42†	97330666	GASKET, CYLINDER	1
43**	54571609	GASKET, HEAD	1
44	97330682	GLASS, SIGHT	1
45	97330690	HEAD	1
46	70243936	ASSEMBLY, VENT	1
47	70243399	FILTER, AIR	1
NI	70243712	• ELEMENT, FILTER	1

NSS	NOT SOLD SEPERATELY
**	AVAILABLE INDIVIDUALLY OR IN VALVE KIT 97338107
†	AVAILABLE INDIVIDUALLY OR IN PISTON RING KIT 97338115

SS3 - COMPRESSOR PARTS LIST

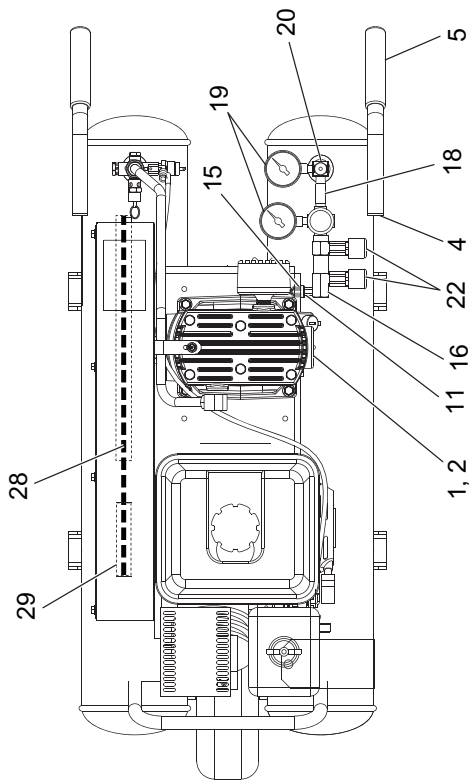

23A, 23B, 24,
25, 26

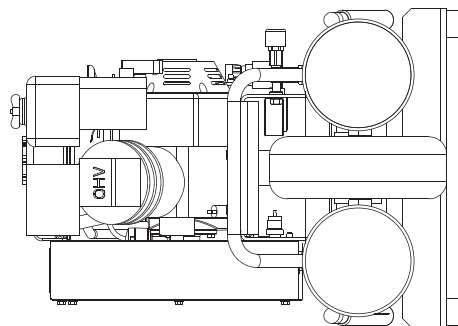
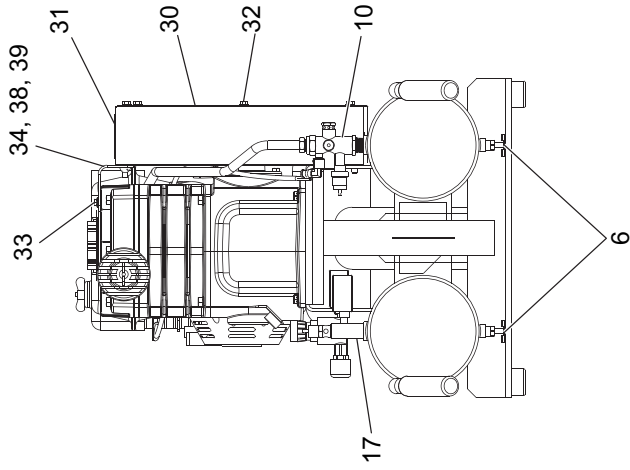
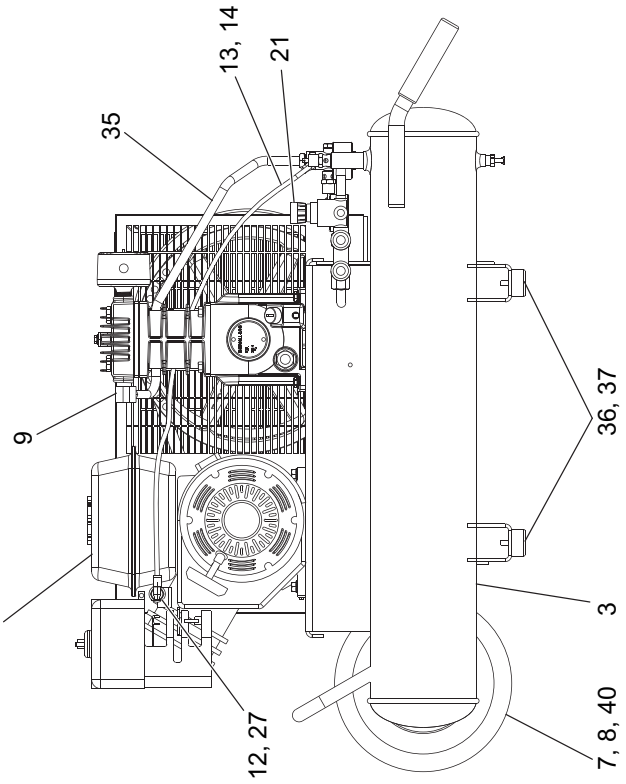

SS3 - COMPRESSOR PARTS LIST

Item	CCN	DESCRIPTION	Qty.
1	97330419	PUMP, BARE COMPRESSOR	1
2	56290794	SCREW	4
3	22866552	RECEIVER TANK	1
4	54394036	CAP PLUG	2
5	97171060	HANDLE GRIP	2
6	32027120	MANUAL DRAIN VALVE	2
7	54389572	AXLE	1
8	47633135001	WHEEL	1
9	95040184	ELBOW, TUBE 1/2X3/8	1
10	47600594001	VALVE-UNLOADER ASSEMBLY	1
11	18007138	STUD, MANIFOLD SS3 WHEELBAR	1
12	39155577	ELBOW	2
13	97265912	UNLOADER TUBE	1
14	97182240	NYLON TUBE INSERT	2
15	39128566	NUT	1
16	18007112	BODY, MANIFOLD ASSY	1
17	18007120	FITTING, MANIFOLD ASSY	2
18	95871463	NIPPLE	1
19	54494075	PRESSURE GAUGE	2
20	97010094	SAFETY VALVE	1
21	37992849	PRESSURE REGULATOR	1

Item	CCN	DESCRIPTION	Qty.
22	32238354	COUPLER	2
23A	97339451	ENGINE (HONDA)	1
23B	47617263001	ENGINE (KOHLER)	1
24	58879461	CAPSCREW	4
25	54391545	NUT	4
26	95094389	KEY	1
27	47619810001	ACTUATOR, SMALL ENGINE SLOW-DOWN	1
28	32205601	BELT	1
29	22921860	SHEAVE	1
30	54459508	BELTGUARD, FRONT	1
31	54459516	BELTGUARD, REAR	1
32	97173595	CAPSCREW	14
33	56280159	SCREW	1
34	54640032	BRACE, BELTGUARD	1
35	49812324	PUMP TO UNLOADER TUBE	1
36	97175343	ISOLATOR PAD	4
37	97175350	SCREW	4
38	32175564	SCREW	1
39	39128541	NUT	1
40	54657218	NUT	1

SS5 - BARE COMPRESSOR PUMP ASSEMBLY

■ MODEL SS5 BARE COMPRESSOR PUMP

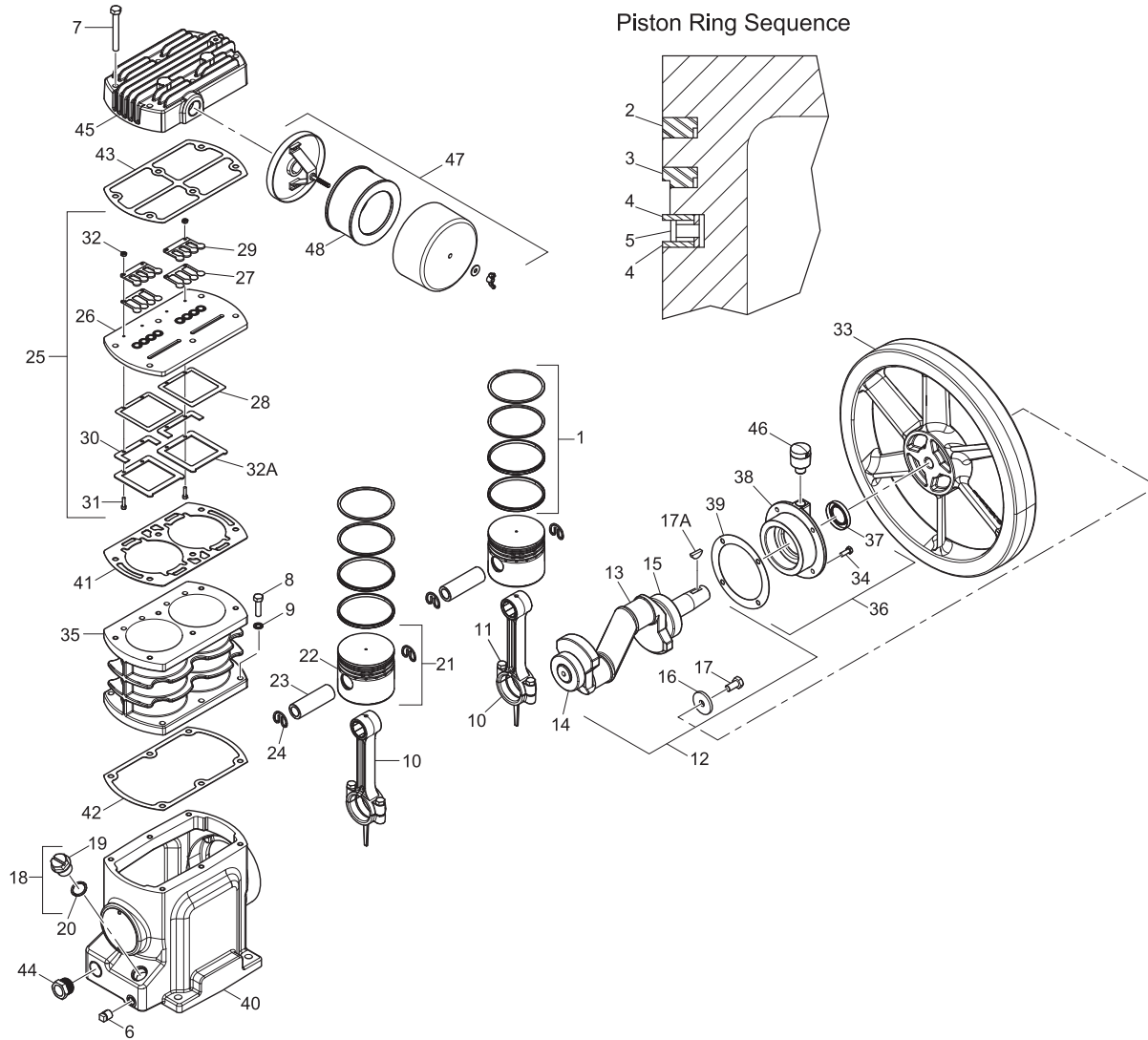

NOTE:

- Item 12 includes Item 13, 14, 15, 16 and 17
- Item 18 includes of Item 19 and 20
- Item 21 includes of Item 22, 23 and 24
- Item 25 includes of Item 26, 27, 28, 29, 30, 31, 32 and 32A
- Item 36 includes of Item 37, 38 and 39
- Item 47 includes of Item 48

SS5 - BARE COMPRESSOR PUMP ASSEMBLY

Item	PART NO.	DESCRIPTION	QTY
REF.	97334148	PUMP, BARE COMPRESSOR	-
1†	20102703	SET, PISTON RING	2
2	NSS	• RING, COMPRESSION	2
3	NSS	• RING, SCRAPER	2
4	NSS	• RING, OIL CONTROL SPACER	4
5	NSS	• RING, OIL CONTROL	2
6	95033593	PLUG, OIL DRAIN	1
7	96706874	CAPSCREW. M8X65 (HEAD BOLT)	6
8	96702253	CAPSCREW. M8 X25 (CYLINDER BOLT)	6
9	96728316	WASHER. SPRING- M8	6
10	97333173	ASSEMBLY. CONNECTING ROD	2
11	96705876	• CAPSCREW, M8 X 35	4
12	20102711	ASSEMBLY, CRANKSHAFT - SERVICE	1
13	NSS	• CRANKSHAFT	1
14	NSS	• BEARING, MAIN	1
15	NSS	• BEARING, BALL	1
16	54423504	• WASHER	1
17	96730437	• CAPSCREW, M8 X 20 - LEFT HAND THREAD	1
17A	95245494	• KEY, WOODRUFF	
18	97334254	ASSEMBLY, OIL FILL PLUG	1
19	NSS	• PLUG. OIL FILL	1
20	97334288	• O-RING, OIL FILL PLUG	1
21	97333389	• ASSEMBLY, PISTON & PIN	1
22	NSS	• PISTON	1
23	NSS	• PIN, PISTON	1
24	NSS	• RING, LOCK	2
25**	97335061	ASSEMBLY VALVE	1
26	NSS	• PLATE, VALVE	1

Item	PART NO.	DESCRIPTION	QTY
27	NSS	• VALVE, DISCHARGE	2
28	NSS	• VALVE, INLET	2
29	NSS	• STOP, DISCHARGE	2
30	NSS	• RETAINER, INLET	2
31	NSS	• SCREW, HEX HEAD - M3 X 16	4
32	NSS	• NUT, HEX - M3 W/ LOCKWASHER	4
32A	NSS	• STOP, INLET	2
33	97335756	BELT WHEEL	1
34	97330500	CAPSCREW, M6 X 14 (END COVER BOLTS)	4
35	97333488	CYLINDER	1
36	20102729	ASSEMBLY, END COVER - SERVICE	1
37	97335624	• SEAL, SHAFT	1
38	NSS	• COVER END	1
39	97333843	• GASKET, END COVER	1
40	97334171	FRAME, COMPRESSOR	1
41	54429600	GASKET, VALVE PLATE	1
42	97333546	GASKET, CYLINDER	1
43	54410667	GASKET, HEAD	1
44	97334270	GLASS, SIGHT	1
45	54410683	HEAD	1
46	70243936	ASSEMBLY, VENT	1
47	54406640	FILTER, INLET	1
48	32170979	• ELEMENT, FILTER	1

NSS	NOT SOLD SEPARATELY
**	AVAILABLE INDIVIDUALLY OR IN VALVE KIT 20100277
†	AVAILABLE INDIVIDUALLY OR IN PISTON RING KIT 20100285

SS5 - COMPRESSOR PARTS LIST

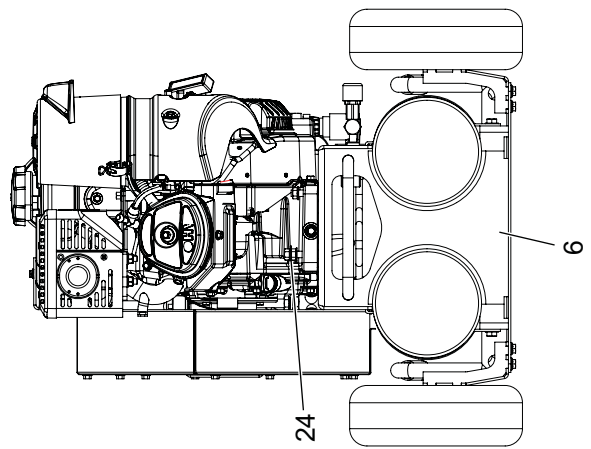
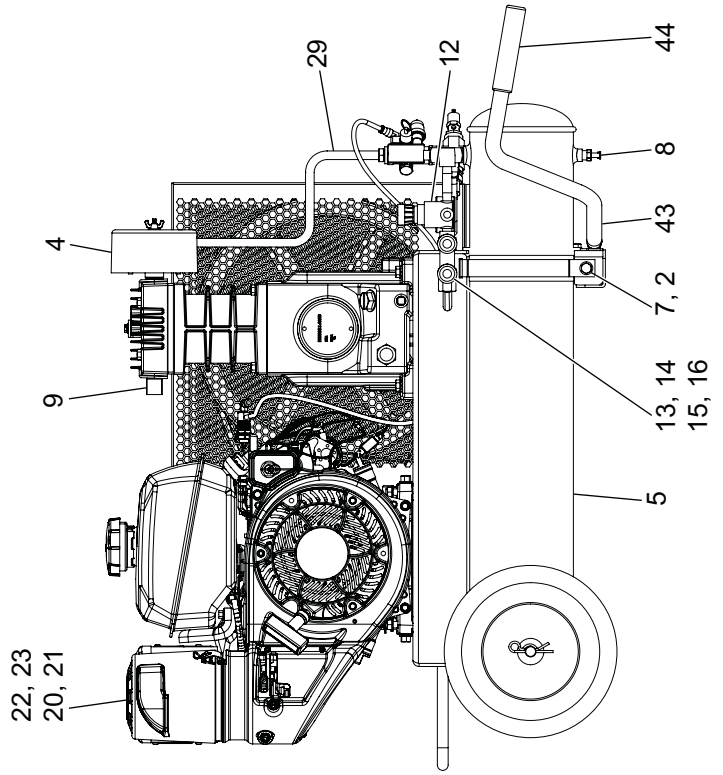
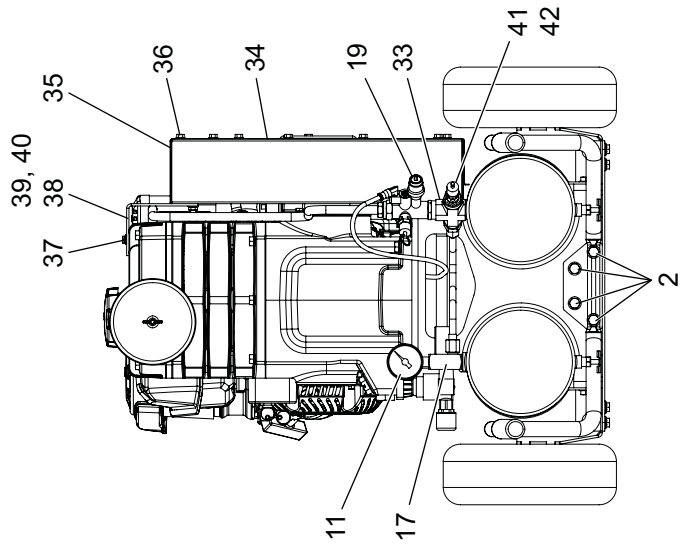
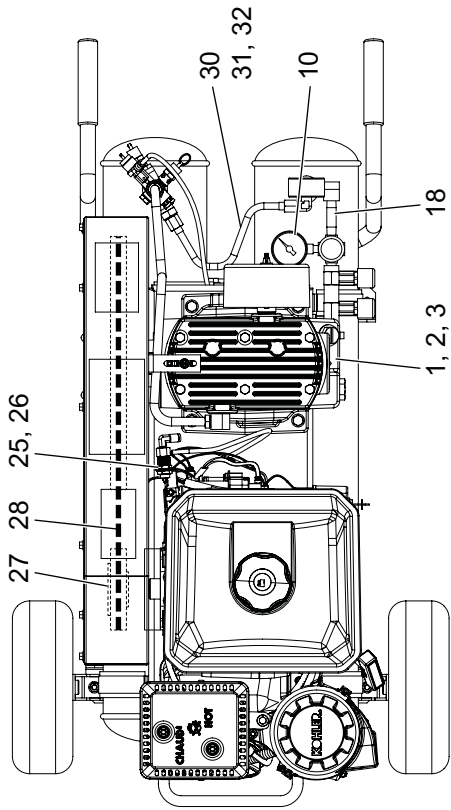

SS5 - COMPRESSOR PARTS LIST

Item	CCN	DESCRIPTION	Qty.
1	97334148	BARE, SS5	1
2	24205064	SCREW	10
3	95750394	WASHER	4
4	32170946	FILTER	1
5	47625510001	RECEIVER	2
6	47625511001	FLOATING TANK WB BASE ASSEMBLY	1
7	47625509001	CLAMP, FLOATING TANK	4
8	32027120	VALVE DRAIN, MANUAL	2
9	95031720	ELBOW, TUBE	1
10	54494075	GAUGE	1
11	32013872	GAUGE	1
12	37992849	REGULATOR	1
13	32238354	COUPLER	2
14	18007112	BODY, MANIFOLD ASSEMBLY	1
15	18007138	STUD, MANIFOLD WHEEL BARROW	1
16	39128566	NUT	1
17	47628308001	FITTING, FLOATING TANK MANIFOLD	1
18	95871463	NIPPLE	1
19	47600594001	UNLOADER VALVE ASSEMBLY	1
20	47625514001	ENGINE, 9.5HP KOHLER	1
21	95825782	CAPSCREW	4
22	39128566	NUT	4
23	95203444	KEY	1
24	54370523	NUT	1
25	47627668001	ACTUATOR, LARGE KOHLER ENGINE SLOW DOWN	1

Item	CCN	DESCRIPTION	Qty.
26	39155577	ELBOW	1
27	47626839001	SHEAVE SET	1
28	47626840001	BELT	1
29	47627666001	TUBE, PUMP TO UNLOADER SS5 WHEEL BARROW	1
30	47627667001	TUBE, CONNECTION FOR FLOATING WB	1
31	95943213	CONNECTOR	1
32	95209094	ELBOW, TUBE FITTING	1
33	47668655001	CROSS	1
34	47625868001	BELTGUARD, FRONT	1
35	47625869001	BELTGUARD BACK	1
36	97173595	CAPSCREW	13
37	56280159	SCREW	1
38	32188518	BRACE-BELTGUARD	1
39	32175564	CAPSCREW	1
40	95987780	NUT	1
41	97010094	VALVE, SAFETY	1
42	32179012	BUSHING	1
43	47625513001	HANDLE, WB	1
44	97171060	GRIP-HANDLE	2
**	39117312	GASKET	40
**	47628337001	TRIM	40
**	39124813	TUBE	A/R

**	NOT ILLUSTRATED
A/R	AS REQUIRED

SS5 - COMPRESSOR WHEEL ASSEMBLY PARTS LIST

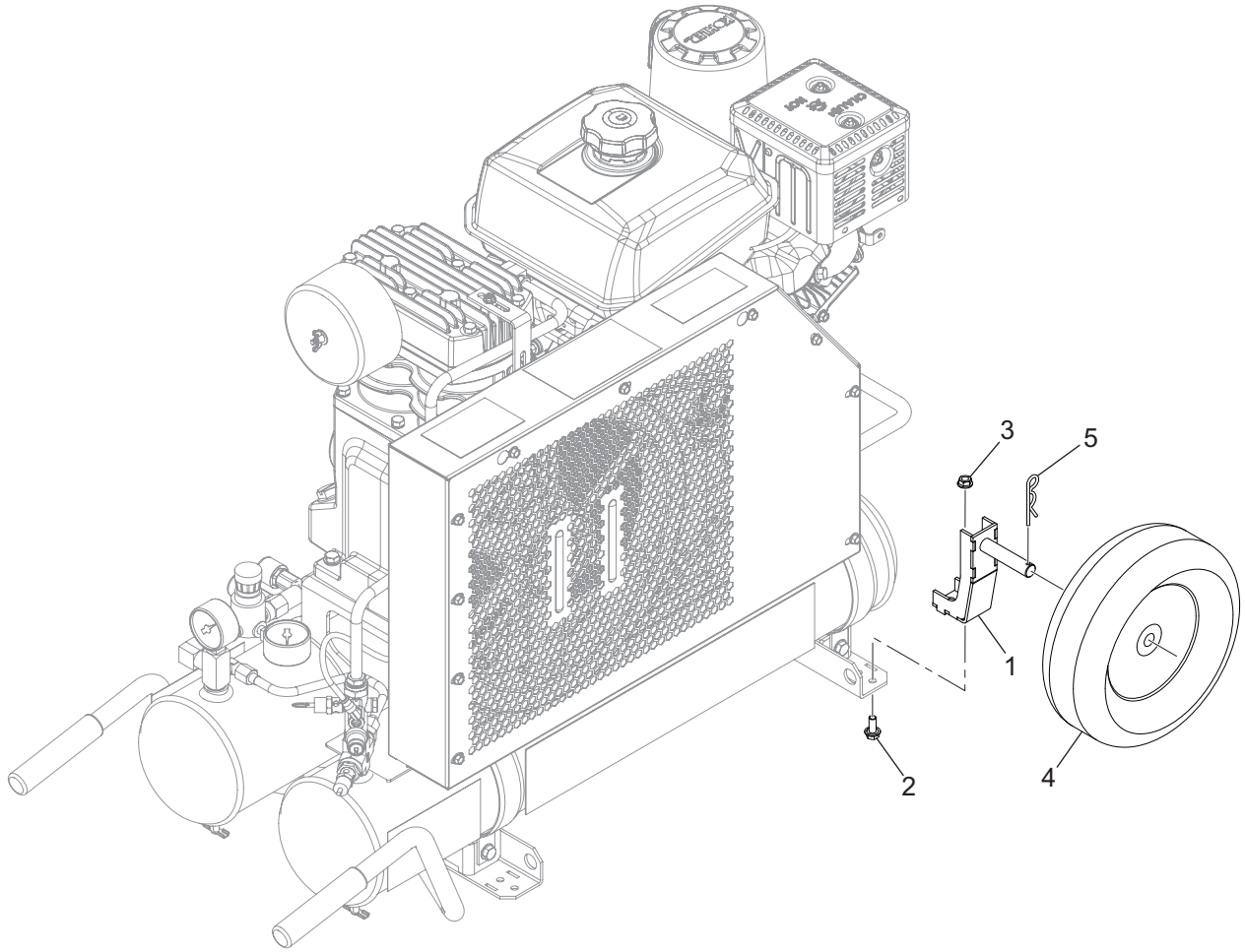

Item	CCN	DESCRIPTION	Qty.
1	47625512001	BRACKET, WB WHEEL MOUNT	2
2	32164634	SCREW	4
3	39128558	NUT	4

Item	CCN	DESCRIPTION	Qty.
4	47633135001	WHEEL	2
5	95433819	PIN, COTTER	2

KITS & ACCESSORIES

■ START-UP KIT

Each start-up kit contains one (1) bottle of **Ingersoll-Rand Contractor Series Synthetic Lubricant**, one (1) air filter element and the necessary engine parts and oil to start-up and maintain your unit for the first year.

PART NO	DESCRIPTION
47623376001	START-UP KIT (KOHLER) 5.5HP
97339501	START-UP KIT (HONDA) 5.5HP
47633855001	START-UP KIT (KOHLER) 9.5HP

■ INGERSOLL-RAND SYNTHETIC COMPRESSOR LUBRICANT

PART NO	DESCRIPTION
97338131	LUBRICANT, 5L, BOTTLE
97338149	LUBRICANT, 6-PACK OF 5L BOTTLES

■ AIR FILTER ELEMENT

PART NO	DESCRIPTION
70243712	AIR FILTER ELEMENT SS3
32170979	AIR FILTER ELEMENT SS5

■ STEP SAVER KITS

Step Saver Kits provide all of the parts required to perform common repair tasks such as piston ring replacement or valve replacement.

PART NO	DESCRIPTION	CONTENTS
97338107	KIT, VALVE/GASKET SS3	Valve wearing parts and head gaskets that are destroyed in replacing valve parts.
97338115	KIT, RING/GASKET SS3	Complete set of piston rings, a crankshaft seal, and gaskets that are destroyed in breaking the unit down to replace the rings
20100277	KIT, VALVE/GASKET SS5	Valve wearing parts and head gaskets that are destroyed in replacing valve parts.
20100285	KIT, RING/GASKET SS5	Complete set of piston rings, a crankshaft seal, and gaskets that are destroyed in breaking the unit down to replace the rings

■ CRANKCASE HEATER KIT

Crankcase heaters are recommended when ambient temperatures are consistently below 32° F (0°C). An easy-to-install external crankcase heater kit is intended for aftermarket use.

PART NO	DESCRIPTION
97330385	KIT, CRANKCASE HEATER

■ MULTI-PURPOSE AIR HOSES

These air hose assemblies are heavy duty, light weight hoses designed for 300 PSIG working pressure.

PART NO	DESCRIPTION
32323750	HOSE, AIR 3/8" x 25' (1/4" MALE NPT)
32323768	HOSE, AIR 3/8" x 50' (1/4" MALE NPT)
32323776	HOSE, AIR 3/8" x 100' (1/4" MALE NPT)

■ ENGINE PARTS

PART NO	DESCRIPTION
32498552	OIL, ENGINE - QUART
47629343001	COMPLETE, FILTER 5.5HP (KOHLER)
54405071	ELEMENT, ENGINE AIR FILTER (HONDA) 5.5HP
47634393001	FILTER 9.5HP

WARRANTY AND LIMITATION OF LIABILITY

■ WARRANTY

Ingersoll Rand company warrants that the equipment manufactured by it and delivered hereunder shall be free of defects in material and workmanship for a period of twelve (12) months from the date of placing the equipment in operation or eighteen (18) months from the date of shipment, whichever shall occur first. The foregoing warranty period shall apply to all equipment, except the following:

1. Compressors that are operated solely on **Ingersoll Rand** synthetic lubricant will have their bare compressor warranted for the earlier of twenty-four (24) months from the date of initial operation or thirty (30) months from the date of shipment.
2. Replacement parts will be warranted for six (6) months from the date of shipment. Should any failure to confirm this warranty be reported in writing to the company within said period, the company shall, at its option, correct such non-conformity by suitable repair to such equipment, or furnish a replacement part F.O.B point of shipment, provided the purchaser has installed, maintained and operated such equipment in accordance with good industry practice and has complied with specific recommendations of the company. Accessories or equipment furnished by the company, but manufactured by others, shall carry whatever warranty the manufacturer conveyed to **Ingersoll Rand** Company and which can be passed on to the purchaser. The company shall not be liable for any repairs, replacements, or adjustments to the equipment or any costs of labour performed by the purchaser without company's prior written approval.

The company makes no performance warranty unless specifically stated within its proposal and the effects of corrosion, erosion and normal wear and tear are specifically excluded from the company's warranty. In the event performance warranties are expressly included, the company's obligation shall be to correct in the manner and for the period of time provided above.

THE COMPANY MAKES NO OTHER WARRANTY OF REPRESENTATION OF ANY KIND WHATSOEVER, EXPRESSED OR IMPLIED, EXCEPT THAT OF TITLE, AND ALL IMPLIED WARRANTIES OF MERCHANTABILITY AND FITNESS FOR A PARTICULAR PURPOSE, AND HEREBY DISCLAIMED.

Correction by the company of non-conformities, whether patent or latent, in the manner and for the period of time provided above, shall constitute fulfillment of all liabilities of the company and its distributors for such non-conformities with respect to or arising out of such equipment.

■ LIMITATION OF LIABILITY

THE REMEDIES OF THE PURCHASER SET FORTH HEREIN ARE EXCLUSIVE, AND THE TOTAL LIABILITY OF THE COMPANY, ITS DISTRIBUTORS AND SUPPLIERS WITH RESPECT TO CONTRACT OR THE EQUIPMENT AND SERVICES FURNISHED, IN CONNECTION WITH THE PERFORMANCE OR BREACH THEREOF, OR FROM THE MANUFACTURE, SALE, DELIVERY, INSTALLATION, REPAIR OR TECHNICAL DIRECTION COVERED BY OR FURNISHED UNDER CONTRACT, WHETHER BASED ON CONTRACT, WARRANTY, NEGLIGENCE, INDEMNITY, STRICT LIABILITY OR OTHERWISE SHALL NOT EXCEED THE PURCHASE PRICE OF THE UNIT OF EQUIPMENT UPON WHICH SUCH LIABILITY IS BASED.

THE COMPANY, ITS DISTRIBUTORS AND ITS SUPPLIERS SHALL IN NO EVENT BE LIABLE TO THE PURCHASER, ANY SUCCESSORS IN INTEREST OR ANY BENEFICIARY OR ASSIGNEE OF THE CONTRACT FOR ANY CONSEQUENTIAL, INCIDENTAL, INDIRECT, SPECIAL OR PUNITIVE DAMAGES ARISING OUT OF THIS CONTRACT OR ANY BREACH THEREOF, OR ANY DEFECT IN, OR FAILURE OF, OR MALFUNCTION OF THE EQUIPMENT, WHETHER OR NOT BASED UPON LOSS OF USE, LOSS PROFITS OR REVENUE, INTEREST, LOST GOODWILL, WORK STOPPAGE, IMPAIRMENT OF THE OTHER GOODS, LOSS BY REASON OF SHUTDOWN OR NON-OPERATION, INCREASED FOR SERVICE INTERRUPTION WHETHER OR NOT SUCH LOSS OR DAMAGE IS BASED ON CONTRACT, WARRANTY, NEGLIGENCE, INDEMNITY, STRICT LIABILITY OR OTHERWISE.



A series of horizontal lines spanning the width of the page, intended for writing or drawing.



A series of horizontal lines spanning the width of the page, providing a template for writing.



A series of horizontal lines spanning the width of the page, providing a template for writing.

