



60 Gal. Hi-Flow Electric Air Compressor

Owner's Manual



! WARNING: Read carefully and understand all ASSEMBLY AND OPERATION INSTRUCTIONS before operating. Failure to follow the safety rules and other basic safety precautions may result in serious personal injury.

Item #75710

READ & SAVE THESE INSTRUCTIONS

Thank you very much for choosing a NorthStar® product!

For future reference, please complete the owner's record below:

Serial Number/Lot Date Code: _____

Purchase Date: _____

Save the receipt, warranty, and this manual. It is important that you read the entire manual to become familiar with this product before you begin using it.

This air compressor is designed for certain applications only. Northern Tool and Equipment is not responsible for issues arising from modification or improper use of this product such as an application for which it was not designed. We strongly recommend that this product not be modified and/or used for any application other than that for which it was designed.

For technical questions, please call 1-888-895-4549.

Table of Contents

Intended Use	5
Packaging Contents	5
Technical Specifications	5
Safety Signal Words	5
Important Safety Information	6
Specific Operation Warnings	9
Main Parts of Compressor	9
Hot Surfaces	10
Assembly	11
Installing Hoses	11
Disconnecting Hoses	12
Installation	12
Lubrication and Oil.....	12
Compatibility	12
Location	12
Humid Areas	12
Noise Considerations	12
Anchoring the Air Compressor	12
Electrical Power Requirements	13
Wiring Instructions	14
Main Power Panel.....	14
Main Power Disconnect Switch	14
Low Voltage Problems.....	14
Grounding Instructions	14
Motor Reset	15
Motor Reset Switch	15
Air Distribution System	15
How to Use Your Unit	16
How to Stop	17
Break-In Procedure	17
Before Each Start-Up	18
Operating Instructions	19
How to Start	19
Shutdown	19
Maintenance	19
Checking Safety Valve	21

Checking Air Filter	21
Draining Air Tank	21
Pump Oil.....	22
Compressor Pump Oil	22
Checking Oil	22
Changing Oil	22
Belt Replacement / Belt Tension / Motor Pulley & Flywheel Adjustment.....	23
Belt Replacement	23
Adjusting Belt Tension	23
Motor Pulley/Flywheel Alignment	23
Miscellaneous Maintenance.....	24
Air Compressor Pump Intake and Exhaust Valves	24
Inspect Air Lines and Fittings for Leaks	24
Air Compressor Head Bolts - Torqueing	24
Service and Adjustments.....	24
Replace or Clean Check Valve.....	25
Troubleshooting	26
Air Compressor Parts Diagram	29
Air Compressor Parts Diagram	29
Pump Parts Diagram.....	31
Pump Parts List.....	31
Switch Assembly Parts Diagram	33
Switch Assembly Parts List	33
Replacement Parts.....	33
Limited Warranty.....	34

Intended Use

The NorthStar 60 Gallon Hi-Flow Electric Air Compressor provides compressed air for air tools and pressurized objects that require high air pressure.

- Maximum Efficiency: Heavy-duty 230V induction motor for maximum performance and efficiency.
- Long Lasting Operation: One-piece cast iron oil-lubricated pump for long service life.
- Efficient Operation: Three-cylinder design provides consistent cooling for long pump life.

Note: Not intended for low-pressure objects such as balloons, air mattresses, and sport balls, which can explode quickly and easily. Special precautions are necessary when used for cleaning to prevent flying debris hazards. It is not to be used to supply breathing air.

Packaging Contents

- Air Compressor
- Owner's Manual
- Air Compressor Information Sheet

Technical Specifications

Property	Specification
Model	NSLA4706065
Weight	287 lb.
Height	73"
Width	37"
Running HP	4.7
Tank Capacity	60 Gallons
Voltage/Amps/Phase	230 Volts / 22 Amps / 1 Phase
Kick-in Pressure	125 PSI (8,62 bar)
Kick-out Pressure	155 PSI (10,69 bar)
Air Delivery	14.0 CFM @ 90 PSI
	16.1 CFM @ 40 PSI
Noise Rating	82.7 dB
Pump Type	Belt Drive

Safety Signal Words

The definitions below describe the level of severity for each signal word. Please read the manual and pay attention to the following.

- ▲ **DANGER:** Indicates an imminently hazardous situation which, if not avoided, **will** result in **death or serious injury**.
- ▲ **WARNING:** Indicates a potentially hazardous situation which, if not avoided, **could** result in **death or serious injury**.
- ▲ **CAUTION:** Indicates a potentially hazardous situation which, if not avoided, **may** result in **minor or moderate injury**.

Important Safety Information

⚠️WARNING

- Read and understand all instructions. Failure to follow all instructions may result in serious injury or property damage.
- The warnings, cautions, and instructions in this manual cannot cover all possible conditions or situations that could occur. Exercise common sense and caution when using this tool. Always be aware of the environment and ensure that the tool is used in a safe and responsible manner.
- Do not allow persons to operate or assemble the product until they have read this manual and have developed a thorough understanding of how it works.
- Do not modify this product in any way. Unauthorized modification may impair the function and/or safety and could affect the life of the product. There are specific applications for which the product was designed.
- Use the right tool for the job. DO NOT attempt to force small equipment to do the work of larger industrial equipment. There are certain applications for which this equipment was designed. This product will be safer and do a better job at the capacity for which it was intended. DO NOT use this equipment for a purpose for which it was not intended.
- Industrial or commercial applications must follow OSHA requirements.

⚠️WARNING

PROP 65

- This product can expose you to chemicals including lead, which is known to the State of California to cause cancer and birth defects or other reproductive harm. For more information, go to www.p65warnings.ca.gov.

⚠️WARNING

WORK AREA SAFETY

- Inspect the work area before each use. Keep work area clean, dry, free of clutter, and well-lit. Cluttered, wet, or dark work areas can result in injury. Using the product in confined work areas may put you dangerously close to cutting tools and rotating parts.
- Do not use the product where there is a risk of causing a fire or an explosion; e.g., in the presence of flammable liquids, gases, or dust. The product can create sparks, which may ignite the flammable liquids, gases, or dust.
- Do not allow the product to come into contact with an electrical source. The tool is not insulated and contact will cause electrical shock.
- Keep children and bystanders away from the work area while operating the tool. Do not allow children to handle the product.
- Be aware of all power lines, electrical circuits, water pipes, and other mechanical hazards in your work area. Some of these hazards may be hidden from your view and may cause personal injury and/or property damage if contacted.

- Keep your work area clean and well lit. Ensure floors are not slippery from wax or dust.
- The compressed air directly from your compressor is not safe for breathing. The air stream may contain carbon monoxide, toxic vapors, or solid particles from the air tank. Breathing these contaminants can cause serious injury or death. Never use air obtained directly from the compressor to supply air for human consumption. The compressor is not equipped with suitable filters and in-line safety equipment for human consumption.
- Never drill into, weld or make any modifications to the air tank or its attachments. Never attempt to repair a damaged or leaking air tank. Replace with a new air tank.
- The air tank is designed to withstand specific operating pressures. Never make adjustments or parts substitutions to alter the factory set operating pressures.
- Over inflation of tires could result in serious injury and property damage. NOTE: Air tanks, compressors and similar equipment used to inflate tires can fill small tires very rapidly. Adjust pressure regulator on air supply to no more than the rating of the tire pressure. Add air in small increments and frequently use the tire gauge to prevent over inflation.
- Oil can leak or spill and could result in fire or breathing hazard; serious injury or death can result. Oil leaks will damage carpet, paint or other surfaces in vehicles or trailers. Always place compressor on a protective mat when transporting to protect against damage to vehicle from leaks. Remove compressor from vehicle immediately upon arrival at your destination. Always keep compressor level and never lie on its side.

⚠ WARNING

PERSONAL SAFETY

- Stay alert, watch what you are doing, and use common sense when operating the tool. Do not use the tool while you are tired or under the influence of drugs, alcohol, or medication. A moment of inattention while operating the tool may result in serious personal injury.
- Dress properly. Do not wear loose clothing, dangling objects, or jewelry. Keep your hair, clothing and gloves away from moving parts. Loose clothes, jewelry, or long hair can be caught in moving parts. Air vents on the tool often cover moving parts and should be avoided.
- Wear the proper personal protective equipment when necessary. Use ANSI Z87.1 compliant safety goggles (not safety glasses) with side shields, or when needed, a face shield. Use a dust mask in dusty work conditions. Also use non-skid safety shoes, hardhat, gloves, dust collection systems, and hearing protection when appropriate. This applies to all persons in the work area.
- Work in an area with good cross ventilation. Read and follow the safety instructions provided on the label or safety data sheets for the materials you are spraying. Always use certified safety equipment: NIOSH/OSHA respiratory protection or properly fit-ting face mask designed for use with your specific application.
- Do not overreach. Keep proper footing and balance at all times.
- Remove keys or wrenches before connecting the tool to an air supply, power supply, or turning on the tool. A wrench or key that is left attached to a rotating part of the tool may cause personal injury.
- Secure the work with clamps or a vise instead of your hand when practical. This safety precaution allows for proper tool operation using both hands.
- Never touch any exposed metal parts on compressor during or immediately after operation. The compressor will remain hot for several minutes after operation. Do not reach around protective shrouds or attempt maintenance until the unit has been allowed to cool.

- The compressed air stream can cause soft tissue damage to exposed skin and can propel dirt, chips, loose particles and small objects at high speed, resulting in property damage or personal injury. Never point any nozzle or sprayer toward any part of the body or at other people or animals.

⚠CAUTION

AIR COMPRESSOR USE AND CARE

- Do not force the air compressor. Products are safer and do a better job when used in the manner for which they are designed. Plan your work and use the correct product for the job.
- Check for damaged parts before each use. Carefully check that the product will operate properly and perform its intended function. Replace damaged or worn parts immediately. Never operate the product with a damaged part.
- Do not use a product with a malfunctioning switch. Any power tool that cannot be controlled with the power switch is dangerous and must be repaired by an authorized service representative before using.
- Disconnect the power/air supply from the product and place the switch in the locked or off position before making any adjustments, changing accessories, or storing the tool. Such preventive safety measures reduce the risk of starting the tool accidentally.
- Store the product when it is not in use. Store it in a dry, secure place out of the reach of children. Inspect the tool for good working condition prior to storage and before re-use.
- Use only accessories that are recommended by the manufacturer for use with your product. Accessories that may be suitable for one product may create a risk of injury when used with another tool. Never use an accessory that has a lower operating speed or operating pressure than the tool itself.
- Keep guards in place and in working order. Never operate the product without the guards in place.
- Do not leave the tool running unattended.
- Drain the moisture from the tank on a daily basis. A clean, dry tank will help prevent corrosion.
- Pull the pressure relief valve ring daily to ensure that the valve is functioning properly, and to clear the valve of any possible obstructions.
- To provide proper ventilation for cooling, the compressor must be kept a minimum of 12 inches (31 cm) from the nearest wall, in a well-ventilated area.
- Fasten the compressor down securely if transporting is necessary. Pressure must be released from the tank before transporting.
- Protect the air hose and electric cord from damage and puncture. Inspect them weekly for weak or worn spots and replace if necessary.
- To reduce the risk of electric shock, do not expose to rain. Store indoors.
- Never operate the compressor if the power cord or plug are damaged. Take the equipment to the nearest Authorized Service Center, and a specialist technician will replace it.
- The compressor is too heavy to be lifted by one person. Obtain assistance from others before lifting.

Specific Operation Warnings

⚠WARNING

- Repairs attempted by unqualified personnel can result in serious injury or death by electrocution. Any electrical wiring or repairs required on this product should be performed by authorized service center personnel in accordance with national and local electrical codes.
- Failure to provide adequate grounding to this product could result in serious injury or death from electrocution. Refer to the grounding instructions paragraph in the Installation section. Make certain that the electrical circuit to which the compressor is connected provides proper electrical grounding, correct voltage and adequate fuse protection.
- Under some conditions and duration of use, noise from this product may contribute to hearing loss. Always wear certified safety equipment: ANSI S12.6 (S3.19) hearing protection.
- Exceeding the pressure rating of air tools, spray guns, air operated accessories, tires and other inflatables can cause them to explode or fly apart and could result in serious injury. Follow the equipment manufacturer's recommendation and never exceed the maximum allowable pressure rating of attachments. Never use compressor to inflate small low-pressure objects such as children's toys, footballs, basketballs, etc.
- Drain air tank daily or after each use. If air tank develops a leak, replace it immediately with a new air tank or replace the entire compressor.

Main Parts of Compressor

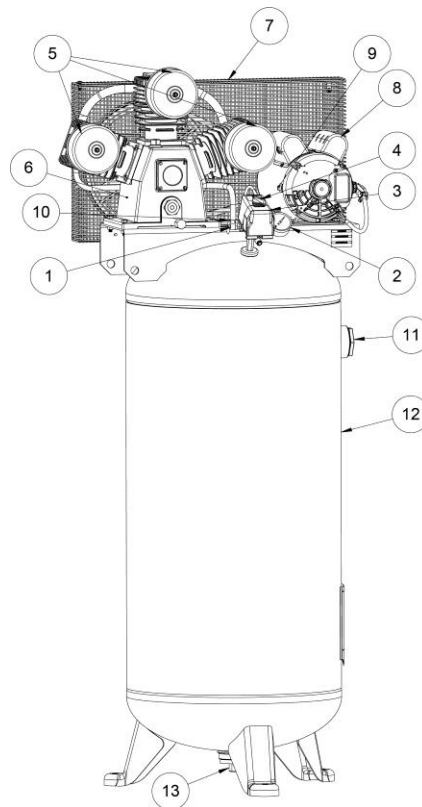

Figure A

Components	
1.	Safety Valve: This valve is designed to prevent system failures by relieving pressure from the system when the compressed air reaches a predetermined level. The valve is preset by the manufacturer and must not be removed or modified in any way.
2.	Tank Pressure Gauge: The tank pressure gauge indicates the reserve air pressure in the tank.
3.	Pressure Switch: The pressure switch automatically starts the motor when the air tank pressure drops below the factory set cut-in pressure. It stops the motor when the air tank pressure reaches the factory set cut-out pressure.
4.	Pressure Auto (-) / Off (O) Switch: Place this switch in the AUTO (-) position to provide automatic power to the pressure switch and OFF (O) to remove power at the end of each use. NOTE: ALWAYS ensure the switch is in the OFF (O) position before removing or replacing the pressure switch cover.
5.	Air Intake Filters: The filters are designed to clean air entering the pump. To ensure the pump continually receives a clean, cool, and dry air supply, the filters must always be clean and the filter intakes must be free from obstructions.
6.	Air Compressor Pump: The pump compresses air into the air tank. Working air is not available until the compressor has raised the air tank pressure above that required at the air outlet.
7.	Belt Guard: This covers the engine pulley, pump flywheel, and belt. Never operate without the belt guard in place.
8.	Motor: The electric motor powers the pump. The electric motor is equipped with an overload protector to help prevent possible motor burn-out.
9.	Motor Overload Protector: The motor has a thermal overload protector. If the motor overheats for any reason, the overload protector will shut off the motor. The motor must be allowed to cool down before restarting. To restart: <ol style="list-style-type: none"> 1. Set the Auto/Off switch to OFF (O) and unplug unit. 2. Allow the motor to cool. 3. Depress the red reset button on the motor. 4. Plug the power cord into the correct branch circuit receptacle.
10.	Check Valve: When the air compressor is operating, the check valve is open, allowing compressed air to enter the air tank. When the air compressor reaches cut-out pressure, the check valve closes, allowing air pressure to remain inside the air tank.
11.	Air Outlet: Connect an air hose to this outlet.
12.	Air Tank: 60 Gallon ASME tank stores the compressed air.
13.	Air Tank Drain Valve: The drain valve is located at the base of the air tank and is used to drain condensation at the end of each use.
14.	Globe Valve/Air Discharge Valve <i>(sold separately, not shown):</i> Opens and closes air distribution from the compressor. See Air Distribution System .
15.	Regulator <i>(sold separately, not shown):</i> An air pressure regulator or a separate air transformer which combines the functions of air regulation and/or moisture and dirt removal is recommended for most applications. See Air Distribution System .

Hot Surfaces

⚠WARNING

- Never touch any exposed metal parts on compressor during or immediately after operation. The compressor will remain hot for several minutes after operation. Do not reach around protective shrouds or attempt maintenance until the unit has been allowed to cool.

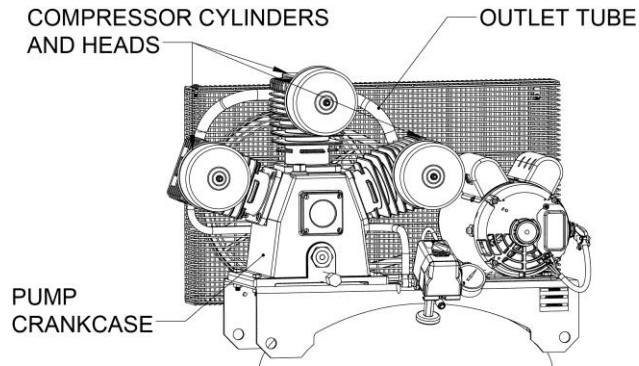

Figure B

Assembly

⚠WARNING

- This compressor was shipped with oil in the pump crankcase. Check oil before operating the air compressor, see **Check Oil** under *Maintenance*.

Unpack the air compressor. Inspect the unit for damage. If the unit has been damaged in transit, contact the carrier and complete a damage claim. Do this immediately because there are time limitations to damage claims. The carton should contain:

- Air Compressor
- Owner's Manual
- Air Compressor Information Sheet

Check the compressor's serial label to ensure that you have received the model ordered, and that it has the required pressure rating for its intended use.

Installing Hoses

⚠WARNING

- **Risk of unsafe operation.** Firmly grasp hose in hand when installing or disconnecting to prevent hose whip.

1. Ensure regulated pressure gauge reads 0 PSI.
2. Apply sealant tape to hose threads.
3. Assemble hose to air outlet. **IMPORTANT:** Do not assemble splitters directly to the air outlet.

NOTE: Assembling quick connect bodies to air outlet and quick connect plugs to hose ends make connecting and disconnecting hoses simple and easy. Quick connect bodies and plugs are available for purchase from your local dealer or authorized service center.

Disconnecting Hoses

1. Ensure regulated pressure gauge reads 0 PSI.
2. Remove hose from air outlet.

Installation

Lubrication and Oil

The air compressor pump was filled with oil at the manufacturer. Check the air compressor pump oil level before operating unit. See **Compressor Pump Oil** under *Pump Oil*.

Compatibility

Air tools and accessories that are run off the compressor must be compatible with petroleum-based products. If you suspect that a material is not compatible with petroleum products, an air line filter for removal of moisture and oil vapor in compressed air is required.

NOTE: Always use an air line filter to remove moisture and oil vapor when spraying paint.

Location

- Place the air compressor in a clean, dry, and well-ventilated area.
- Place the air compressor at least 12" (30.5 cm) away from the wall or other obstructions that will interfere with the flow of air.
- Place the air compressor as close to the main power supply as possible to avoid using long lengths of electrical wiring.
NOTE: Long lengths of electrical wiring could cause power loss to the motor.
- The air filter must be kept clear of obstructions which could reduce air flow to the air compressor.

Humid Areas

In frequently humid areas, moisture may form in the pump and produce sludge in the oil, causing running parts to wear out prematurely. Excessive moisture is especially likely to occur if the unit is located in an unheated area that is subject to large temperature changes. Two signs of excessive humidity are external condensation on the pump when it cools down and a milky appearance in compressor oil. You may be able to prevent moisture from forming in the pump by increasing ventilation or operating for longer intervals.

Noise Considerations

Consult local officials for information regarding acceptable noise levels in your area. To reduce excessive noise, use vibration mounts or silencers, relocate the unit or construct total enclosures or baffle walls.

Anchoring the Air Compressor

⚠ WARNING

- **Risk of bursting.** Excessive vibration can weaken the air tank and cause an explosion. The compressor must be properly mounted.

The air compressor MUST be bolted to a level, solid concrete surface. Use 3/8" lag screws, vibration pads, and concrete anchors. If help is needed anchoring the air compressor, consult a licensed contractor.

1. Place the air compressor on a level, solid concrete surface. Make sure the concrete is in good condition without cracks or damage.
2. Mark the surface using the holes in the air compressor feet as a template.
3. Drill holes in the surface for the concrete anchors. Install concrete anchors.
4. Line-up holes in the surface with holes in the air compressor feet.
5. Place the vibration pads (not supplied) between the floor and air compressor feet. See figure C. If needed, use shims to level the unit.
6. Place the 3/8" lag screws through the air compressor feet, vibration pads, and into the anchors.
7. Torque 3/8" lag screws to 7-10 ft./lb. (9.5-13.5 Nm).

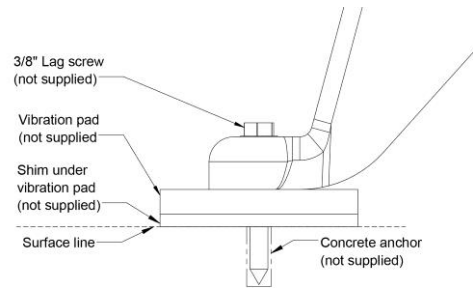

Figure C

⚠ CAUTION

- To prevent damage to tank and compressor on stationary models, the tank must be shimmed so the pump base is level within 1/8" to distribute oil properly. All feet must be supported, shimming where necessary, prior to attaching to the floor. Fasten all feet to floor. We also recommend the use of vibration pads under tank feet.
- The shipping pallet is not designed as a base for an operating compressor. Operating the compressor while it is on the pallet will void your warranty.

Electrical Power Requirements

⚠ WARNING

- **Risk of electrical shock.** Improper electrical grounding can result in electrical shock. The wiring should be done by a qualified electrician.
- Improper electrical installation of this product may void its warranty and your fire insurance. Have circuit wiring performed by qualified personnel such as a licensed electrician who is familiar with the current national electrical code and any prevailing local electrical codes.
- **Risk of electrical shock.** Electrical wiring must be located away from hot surfaces such as manifold assembly, compressor outlet tubes, heads, or cylinders.

Wiring Instructions

A qualified electrician needs to know the following before wiring:

1. The amperage rating of the electrical box should be adequate. Refer to the air compressor's serial label for the unit's voltage and amperage requirements. Ensure that all wiring is done by a licensed electrician, in accordance with the National Electrical Code.
2. The supply line should have the same electrical characteristics (voltage, cycle, and phase) as the motor. Refer to the motor nameplate, on the side of the motor, for this information.

NOTE: The wiring used must be rated for the motor nameplate voltage. Refer to local codes for recommended wire sizes, correct wire size, and maximum wire run; undersize wire causes high amp draw and overheating to the motor.

Main Power Panel

For best performance and reliable starting, the air compressor must be installed on a dedicated circuit, as close as possible to the electrical power panel. Provide circuit breaker or fuse protection at your main power panel. Use time delay fuses on the circuit because the compressor will momentarily draw several times its specified amperage when first started.

NOTE: A circuit breaker is recommended. If the air compressor is connected to a circuit protected by a fuse, use dual element time delay fuses (Buss Fusetron™ type "T" only).

Main Power Disconnect Switch

Install a main power disconnect switch in the line from the panel to the compressor. The main power disconnect switch must be located near the compressor, for ease of use and safety. When turned OFF, the main power disconnect switch shuts off all power to the compressor. When it is turned ON, the compressor will start and stop automatically, controlled by the pressure switch.

Low Voltage Problems

Low voltage will cause difficult starting or an overload. Low voltage can be caused by a low supply voltage from the local power company, other equipment running on the same line, or inadequate wiring. If any other electrical devices are drawing from the compressor's circuit, it may fail to start.

Low voltage to the compressor can be caused by a supply wire of insufficient gauge for the distance between the compressor and the power source. The longer the distance, the larger the wire gauge (lower the number) must be, to overcome the inherent voltage loss caused by the wire resistance. Refer to the National Electrical Code to determine proper wire size for your circuit.

If the wiring is not adequate, the input voltage will drop by 20 to 40 volts at start-up. Low voltage or an overloaded circuit can result in sluggish starting that causes the circuit breaker to trip, especially in cold conditions.

Grounding Instructions

This product should be connected to a metallic, permanent wiring system, of an equipment-grounding terminal or lead on the product.

Motor Reset

⚠WARNING

- Make sure that all guards and shrouds are in place before pressing the reset switch to restart the motor.

Motor Reset Switch

If the motor shuts down because of an overload, wait 10–15 minutes so the motor can cool down, then press (NEVER force) the reset switch (see Figure D) to restart the motor.

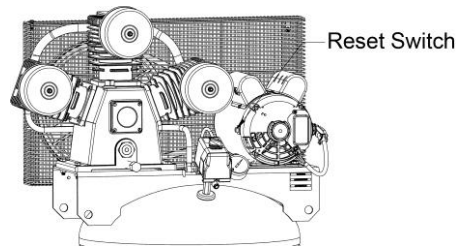

Figure D

Air Distribution System

⚠WARNING

- **Risk of bursting.** Plastic or PVC piping is not designed for use with compressed air. Regardless of its indicated pressure rating, plastic piping can burst from air pressure. Use only metal piping for air distribution lines.

Figure E represents a typical air distribution system. The following are tips to remember when setting up the air compressor's air distribution system.

NOTE: Compressed air from oil lube air compressors will contain water condensation and oil mist. Several drains, traps, and filters will be needed to supply air without water (including aerosols) or oil to spray equipment, air tools, and accessories requiring filtered air. Always read the instructions for the air tools and accessories being used.

- Use piping that is the same size as the air tank outlet. Piping that is too small will restrict the flow of air. If piping is over 100' (30.5 m) long, use the next larger size.
- Bury underground lines below the frost line and avoid pockets where condensation can gather and freeze. Apply pressure before underground lines are covered to make sure all pipe joints are free of leaks.
- A flexible coupling is recommended to be installed between the globe valve/air discharge outlet and main air distribution line to allow for vibration.
- A separate regulator is recommended to control the air pressure. Air pressure from the tank is usually too high for individual air driven tools.
- DO NOT install lubricators between the tank and any spray equipment, air tool, or accessory requiring oil-free filtered air.
- Drain all traps, filters, and dirt legs daily.

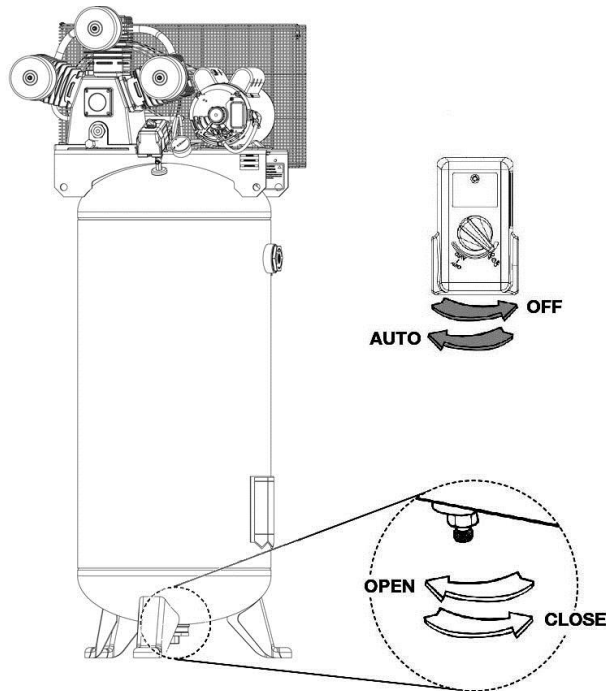

Figure F

How to Stop

Set the Auto/Off switch to OFF.

Break-In Procedure

⚠ WARNING

- **Risk of property damage.** Serious damage may result if the following break-in instructions are not closely followed.

This procedure is required before the air compressor is put into service and when the check valve or a complete compressor pump has been replaced.

1. Make sure the Auto/Off switch is in the OFF position.
2. Check oil level in pump. See the **Pump Oil** section for instruction.
3. Recheck all wiring. Make sure wires are secure at all terminal connections. Make sure all contacts move freely and are not obstructed.
4. Open the drain valve (counter-clockwise) fully to permit air to escape and prevent air pressure build up in the air tank during the break-in period.
5. Move the Auto/Off switch to the AUTO position. The compressor will start.
6. Run the compressor for 30 minutes. Make sure the drain valve and all air lines are open so there is only a minimal air pressure build-up in tank.

NOTE: After about 30 minutes, if the unit does not operate properly, SHUT DOWN IMMEDIATELY, and contact the customer service department.

7. Check all air line fittings and connections/piping for air leaks by applying a soap solution. Correct if necessary.

NOTE: Minor leaks can cause the air compressor to overwork, resulting in premature breakdown or inadequate performance.

8. Check for excessive vibration. Readjust or shim air compressor feet, if necessary.
9. After 30 minutes, turn the Auto/Off switch to the OFF position.
10. Close the drain valve.
11. Turn the Auto/Off switch to the AUTO position. The air receiver will fill to “cut-out” pressure and the motor will stop. The compressor is now ready for use.

Before Each Start-Up

⚠WARNING

- **Risk of unsafe operation.** Firmly grasp air hose in hand when installing or disconnecting to prevent hose whip.
- **Risk of unsafe operation.** Do not use damaged or worn accessories.
- **Risk of bursting.** Too much air pressure causes a hazardous risk of bursting. Check the manufacturer’s maximum pressure rating for air tools and accessories. The regulator outlet pressure must never exceed the maximum pressure rating.

1. Place Auto/Off switch to OFF.
2. Close the drain valve.
3. Visually inspect air lines and fittings for leaks.
4. Check safety valve. See **Checking Safety Valve** in the *Maintenance* section.
5. Attach hose and accessories.

NOTE: A regulator MUST be installed when using accessories rated at less than 135 PSI.

NOTE: The hose or accessory will require a quick connect plug if the air outlet is equipped with a quick connect socket.

⚠CAUTION

- **Risk of unsafe operation.** Compressed air from the unit may contain water condensation and oil mist. Do not spray un-filtered air at an item that could be damaged by moisture. Some air tools and accessories may require filtered air. Read the instructions for the air tools and accessories.

Operating Instructions

⚠WARNING

- **Risk of bursting.** If any unusual noise or vibration is noticed, stop the compressor immediately and have it checked by a trained service technician.

How to Start

1. Turn the Auto/Off switch to AUTO and allow tank pressure to build. Motor will stop when tank pressure reaches “cut-out” pressure.
2. When the tank pressure reaches “cut-out” pressure, open the globe valve/air discharge valve.

IMPORTANT: When using regulator and other accessories, refer to the manufacturer’s instructions.

The compressor is ready for use.

Shutdown

⚠WARNING

- **Risk of unsafe operation.** Firmly grasp air hose in hand when installing or disconnecting to prevent hose whip.
- **Risk of bursting.** Drain air tank daily. Water will condense in air tank. If not drained, water will corrode and weaken the air tank causing a risk of air tank rupture.

1. Move Auto/Off switch to the OFF position.

NOTE: When finished using the compressor, follow steps 2 – 5 below.

2. Remove the hose and accessories.
3. Drain the air tank. See **Draining Air Tank** under *Maintenance*. Ensure the air tank pressure gauge reads 0 psi.
4. Allow the compressor to cool down.
5. Wipe the air compressor clean.

Maintenance

⚠WARNING

- **Risk of unsafe operation.** Unit cycles automatically when power is on. When performing maintenance, you may be exposed to voltage sources, compressed air, or moving parts. Personal injuries can occur. Before performing any maintenance or repair, disconnect power source from the compressor and bleed off all air pressure.
- **Risk of bursting.** If the safety valve does not work properly, over-pressurization may occur, causing air tank

rupture or an explosion.

- **Risk of burn.** Tubes, pump head, and surrounding parts are very hot; do not touch these. See the Hot Surfaces section with areas identified in Figure B. Allow compressor to cool prior to servicing.
- **Risk from flying objects.** Always wear certified safety equipment: ANSI Z87.1 eye protection (CAN/CSA Z94.3 with side shields).
- **Risk from noise.** Use ear protection ANSI S12.6 (S3.19) as air flow noise is loud when draining.
- **Risk of bursting.** Water will condense in the air tank. If not drained, water will corrode and weaken the air tank causing a risk of air tank rupture.
- Drain tank to release air pressure before removing the oil fill cap or oil drain plug.

To ensure efficient operation and longer life of the air compressor outfit, a routine maintenance schedule should be prepared and followed. The following routine maintenance schedule is geared to an outfit in a normal working environment operating on a daily basis. If necessary, the schedule should be modified to suit the conditions under which your compressor is used. The modifications will depend upon the hours of operation and the working environment. Compressor outfits in an extremely dirty and/or hostile environment will require a greater frequency of all maintenance checks. NOTE: See Operation section for the location of controls.

Maintenance Interval	Maintenance Point
Daily	Check safety valve
	Drain air tank
	Check pump oil level
	Oil leak inspection
	Inspect drive belt
	Check for any unusual noise/vibration
	Check for air leaks*
Weekly	Inspect air filter+
	Clean compressor exterior
Monthly or Every 50 Hours	Check drive belt tension
After First 8 hours and Every 100 Operating Hours	Check and tighten all bolts
1 Year or 200 Operating Hours	Change pump oil **+
	Check pulley/flywheel alignment
* To check for air leaks, apply a solution of soapy water around joints. While compressor is pumping to pressure and after pressure cuts out, look for air bubbles to form.	
** The pump oil must be changed after the first 20 hours of operation. Thereafter, when using synthetic blend, non-detergent air compressor oil, change oil every 200 hours of operation or once a year, whichever comes first.	
+ Perform more frequently in dusty or humid conditions.	

Checking Safety Valve

Before starting the compressor, pull the ring on the safety valve to make sure that the safety valve operates freely. If the valve is stuck or does not operate smoothly, it must be replaced with the same type of valve.

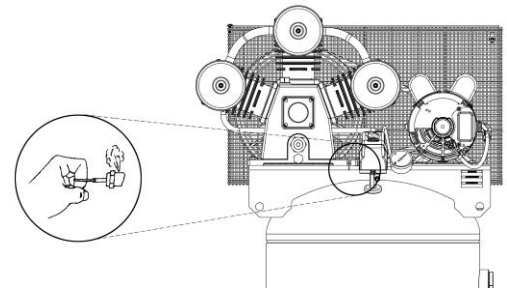

Checking Air Filter

A dirty air filter will not allow the compressor to operate at full capacity. Keep the air filters clean at all times.

1. Ensure Auto/Off switch is in the OFF position.
2. Allow unit to cool.
3. Remove the 3 nuts (A).
4. Remove the outer metal covers (B).
5. Check the filter elements (C). If they are dirty or filled with paint, replace them.
6. Place the outer metal covers back over the filter elements.
7. Secure with the nuts.

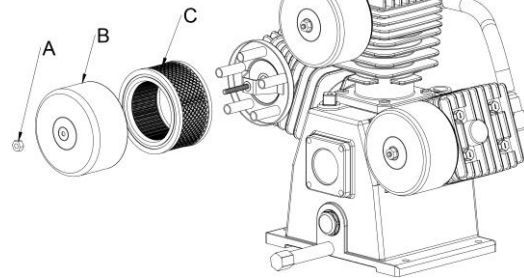

Figure H

⚠ CAUTION

- Risk of unsafe operation. Do not operate without air filters.

Draining Air Tank

All compressed air systems generate condensation that accumulates in any drain point (e.g., tanks, filter, aftercoolers, dryers). This condensate contains lubricating oil and/or substances which may be regulated and must be disposed of in accordance with local, state, and federal laws and regulations.

1. Set the Auto/Off switch to "Off".
2. Remove the air tool or accessory.
3. Pull the ring on the safety valve allowing air to bleed from the tank until tank pressure is approximately 20 PSI. Release the safety valve ring.
4. Drain all of the water from the air tank by opening the drain valve (counter-clockwise) on the bottom of the tank.
5. Risk of property damage. Water drained from the air tank may contain oil and rust which can cause stains on surfaces.
6. After the water has been drained, close the drain valve (clockwise). The air compressor can now be stored.

NOTE: If the drain valve is plugged, release all air pressure. The valve can then be removed, cleaned, then reinstalled.

Pump Oil

Compressor Pump Oil

⚠WARNING

- **Risk of property damage.** Use air compressor oil only. Multi-weight automotive engine oils like 10W30 should not be used in air compressors. They leave carbon deposits on critical components, thus reducing performance and compressor life.
- Use synthetic blend, non-detergent air compressor oil.
- Crankcase oil capacity is approximately 33 fluid ounces (976 ml).

Checking Oil

1. The oil level should be to the middle of the sight glass (G).
2. If needed, remove the oil fill plug (H) and slowly add oil until it reaches the middle of the sight glass.

Changing Oil

1. Remove the oil fill plug (H).
2. Remove the oil drain plug (F) and drain oil into a suitable container.
3. Replace the oil drain plug (F) and tighten securely.
4. Slowly add the compressor oil until it reaches the middle of the sight glass (G).

NOTE: When filling the crankcase, the oil flows very slowly into the pump. If the oil is added too quickly, it will overflow and appear to be full.

⚠CAUTION

- Overfilling with oil will cause premature compressor failure. Do not overfill.

5. Replace the oil fill plug (H) and tighten securely.

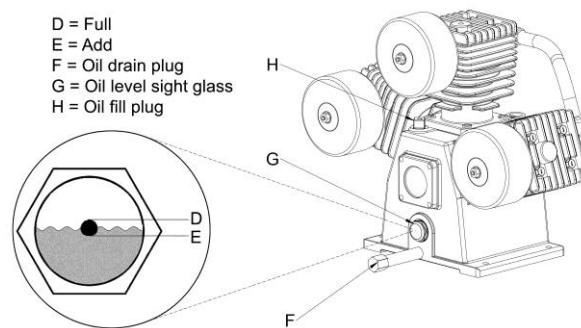

Figure I

Belt Replacement / Belt Tension / Motor Pulley & Flywheel Adjustment

⚠WARNING

- This unit starts automatically. ALWAYS shut off and disconnect the compressor and bleed all pressure from the system before servicing the compressor, and when the compressor is not in use. Do not use the unit with the shrouds or belt guard removed. Serious injury could occur from contact with moving parts.
- **Hot surfaces. Risk of burn.** Pump head and surrounding parts are very hot; do not touch. See the Hot Surfaces section with areas identified in Figure B. Allow compressor to cool prior to servicing.
- **Risk of unsafe operation.** Unit cycles automatically when power is on. When performing maintenance, you may be exposed to voltage sources, compressed air, or moving parts. Personal injuries can occur. Before performing any maintenance or repair, disconnect power source from the compressor and bleed off all air pressure.

Belt Replacement

1. Set the Auto/Off lever to OFF, shut off the main power disconnect, and relieve all air pressure from the air tank.
2. Remove the front of the belt guard by removing the screws (I) using a Torx T25 bit.
3. Mark the motor position on the saddle.
4. Loosen the motor mounting screws and slide the motor toward the air compressor.
5. Remove the belt and replace with a new one.
6. See the **Adjusting Belt Tension** before tightening the motor mounting screws.

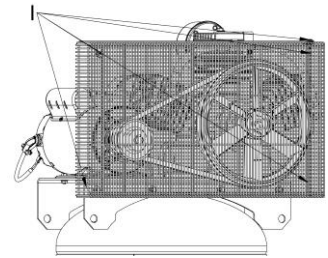

Figure J

Adjusting Belt Tension

1. Slide the motor into the original position and line the motor up with the mark made earlier on saddle.
2. Tighten the two outside motor mounting screws enough to hold the motor in place for checking the pulley and flywheel alignment.
3. The belt should deflect 1/2" (13 mm) at midway between the pulley and the flywheel when a 10-pound (4.6 kg.) weight is applied at the midway point.
4. When the proper belt tension is achieved, tighten all four motor mounting screws. Torque to 20-25 ft./lb. (27.1–33.9 Nm).

NOTE: Once the motor pulley has been moved from its factory set location, the grooves of the flywheel and pulley must be aligned to within 1/16" (1.6 mm) to prevent excessive belt wear. Verify the alignment by performing the following **Motor Pulley/Flywheel Alignment**.

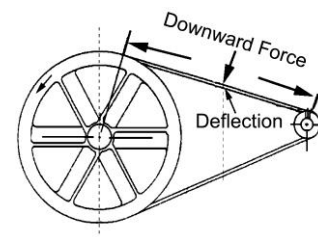

Figure K

Motor Pulley/Flywheel Alignment

NOTE: Once the motor pulley has been moved from its factory set location, the grooves of the flywheel and pulley must be aligned to within 1/16" (1.6 mm) to prevent excessive belt wear. The air compressor flywheel and motor pulley must be in-line (in the same plane) within 1/16" (1.6 mm) to assure belt retention within flywheel belt grooves. To check alignment, perform the following steps:

1. Set the Auto/Off lever to OFF, unplug the unit, and relieve all air pressure from the air tank.
2. Remove the belt guard.
3. Place a straight edge against the outside of the flywheel and the motor drive pulley.

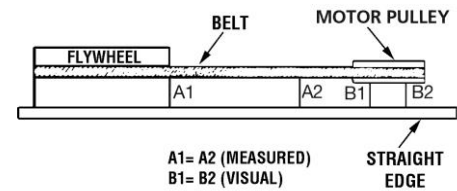

Figure L

4. Measure the distance between the edge of the belt and the straightedge (points A1 and A2 in figure L). The difference between measurements should be no more than 1/16" (1.6 mm).
5. If the difference is greater than 1/16" (1.6 mm), loosen the set screw holding the motor drive pulley to the shaft and adjust the pulley's position on the shaft until the A1 and A2 measurements are within 1/16" (1.6 mm) of each other.
6. Tighten the motor drive pulley set screw.
7. Visually inspect the motor drive pulley to verify that it is perpendicular to the drive motor shaft. Points B1 and B2 of in figure L should appear to be equal. If they are not, loosen the setscrew of the motor drive pulley and equalize B1 and B2.
8. Retighten the motor drive pulley setscrew. Torque to 15–20 ft./lb. (20.3–27.1 Nm).
9. Reinstall the belt guard.

Miscellaneous Maintenance

Air Compressor Pump Intake and Exhaust Valves

Once a year, have a trained service technician check the air compressor pump intake and exhaust valves.

Inspect Air Lines and Fittings for Leaks

1. Set the Auto/Off lever to OFF, shut off the main power disconnect, and relieve all air pressure from the air tank.
2. Apply a soap solution to all air line fittings and the connections/piping.
3. Correct any leaks found.

IMPORTANT: Even minor leaks can cause the air compressor to overwork, resulting in premature breakdown or inadequate performance.

Air Compressor Head Bolts - Torqueing

The air compressor pump head bolts should be kept properly torqued. Check the torques of the head bolts after the first five hours of operation. Torque to 15-18ft./lb. (20-24 Nm).

Service and Adjustments

ALL MAINTENANCE AND REPAIR OPERATIONS NOT LISTED MUST BE PERFORMED BY A TRAINED SERVICE TECHNICIAN.

⚠WARNING

- **Risk of unsafe operation.** Unit cycles automatically when power is on. When performing maintenance, you may be exposed to voltage sources, compressed air, or moving parts. Personal injuries can occur. Before performing any maintenance or repair, disconnect power source from the compressor and bleed off all air pressure.

Replace or Clean Check Valve

1. Release all air pressure from the air tank. See **Draining Air Tank** in the *Maintenance* section.

2. Set the Auto/Off lever to OFF, shut off the main power disconnect, and relieve all air pressure from the air tank.

3. Using an adjustable wrench, loosen the outlet tube nut at the air tank and pump. Carefully move the outlet tube away from the check valve.

4. Using an adjustable wrench, loosen the pressure relief tube nut at the air tank. Carefully move the pressure relief tube away from the check valve.

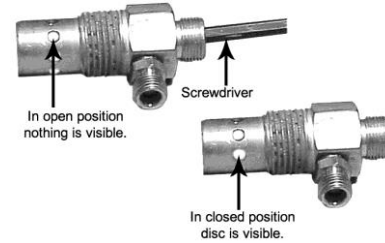

Figure M

5. Unscrew the check valve (turn counter-clockwise) using a 7/8" open end wrench. Note the orientation for reassembly.

6. Using a screwdriver, carefully push the valve disc up and down. Note: The valve disc should move freely up and down on a spring which holds the valve disc in the closed position. If it does not, the check valve needs to be cleaned or replaced.

7. Clean or replace the check valve. A solvent, such as paint or varnish remover, can be used to clean the check valve.

8. Apply sealant to the check valve threads. Reinstall the check valve (turn clockwise).

9. Replace the pressure release tube. Tighten the nuts.

10. Replace the outlet tube and tighten the nuts.

11. Perform the Break-in Procedure. See **Break-in Procedure** in the *Operation* section.

⚠WARNING

- **Risk of bursting.** Do not drill into, weld or otherwise modify air tank or it will weaken. The air tank can rupture or explode.

Troubleshooting

Failure	Possible Cause	Corrective Action
Air leaks	Fittings are not tight	Tighten fittings where air can be heard escaping. Check fittings with soapy water solution. DO NOT OVERTIGHTEN.
Air leaks in air tank or at air tank welds	Defective air tank	Air tank must be replaced. Do not repair the leak. Warning: Risk of bursting. Do not drill into, weld, or otherwise modify air tank or it will weaken. The air tank can rupture or explode.
Air leaks between head and valve plate	Leaking seals	Contact an authorized service center.
Air leaks from safety valve	Defective safety valve	Operate safety valve manually by pulling on ring. If valve still leaks, it must be replaced.
Compressor is not supplying enough air to operate accessories	Fittings are not tight	Tighten fittings where air can be heard escaping. Check fittings with soapy water solution. DO NOT OVERTIGHTEN.
	Prolonged excessive use of air	Decrease amount of air usage.
	Compressor is not large enough for accessory	Check the accessory air requirement. If it is higher than the SCFM or pressure supplied by your air compressor, a larger compressor is needed to operate accessory.
	Hole in air hose	Check and replace air hose, if required.
	Restricted air intake filter	Clean or replace air intake filter.
	Loose belt	Check belt tension, see Adjusting Belt Tension under Maintenance.
Restricted air intake	Restricted air intake filter	Clean or replace air intake filter.
Oil in discharge air	Restricted air intake filter	Clean or replace air intake filter.
	Piston rings damaged or worn	Contact an authorized service center.
	Oil level too high	Reduce to proper level. See Compressor Pump Oil under Maintenance.
Knocking noise	Defective safety valve	Operate safety valve manually by pulling on ring. If valve still leaks, it must be replaced.
	Loose belt	Check belt tension, see Adjusting Belt Tension under Maintenance.

Failure	Possible Cause	Corrective Action
	Loose pulley	Tighten pulley set screw, torque to 15-20 ft.-lb. (20.3-27.1 Nm).
	Loose flywheel	Tighten flywheel screw, torque to 14-18 ft.-lb. (20.0-24.4 Nm).
	Carbon build-up in pump	Contact an authorized service center.
	Belt too tight	Check belt tension, see Adjusting Belt Tension under Maintenance.
	Pump oil is low	Add synthetic blend, non-detergent air compressor oil to pump. See Compressor Pump Oil under Maintenance.
Excessive belt wear	Loose belt	Check belt tension, see Adjusting Belt Tension under Maintenance.
	Loose pulley	Tighten pulley set screw, torque to 15-20 ft.-lb. (20.3-27.1 Nm).
	Belt too tight	Check belt tension, see Adjusting Belt Tension under Maintenance.
	Pulley misalignment	See Motor Pulley/Flywheel Alignment under Maintenance.
Squealing sound	Loose belt	Check belt tension, see Adjusting Belt Tension under Maintenance.
Moisture in pump crankcase	Fittings are not tight	Tighten fittings where air can be heard escaping. Check fittings with soapy water solution. DO NOT OVERTIGHTEN.
	Leaking seals	Contact an authorized service center.
	Unit operating in damp or humid conditions	Move unit to a dry, well-ventilated area.
	Detergent type oil being used in pump	Drain oil and refill pump with synthetic blend non-detergent air compressor oil.
	Extremely light duty cycles	Run unit for longer duty cycles. It is recommended to run at high throttle 50-75% of the run time and idle for 25% of the run time.
	Piston rings damaged or worn	Contact an authorized service center.
	Cylinder or piston damaged or worn	Contact an authorized service center.
	Compressor cylinder finish worn	Contact an authorized service center.
	Water in pump oil	Drain oil and refill pump with synthetic blend, non-detergent air compressor oil.
Excessive current draw	Belt too tight	Check belt tension, see Adjusting Belt Tension under Maintenance.
	Low voltage/motor overload	Check that power supply is adequate and that compressor is on a dedicated

Failure	Possible Cause	Corrective Action
		circuit. If using extension cord, try using without. If compressor is connected to a circuit protected by a fuse, use dual element time delay fuses (Buss Fuse Tron type "T" only).
	Restricted air passages	Inspect and replace transfer tubes or check valve, as required.
Compressor won't start in cold temperatures	Detergent type oil being used in pump	Drain oil and refill pump with synthetic blend, non-detergent air compressor oil.
	Too much back pressure in tank	Open drain valve when starting motor.
	Compressor too cold	Move compressor to a warmer location.
Compressor stalls	Low voltage motor	Furnish adequate power.
	Bad check valve	Replace check valve.
	Seized pump	Contact an authorized service center.
Overheating	Restricted air passages	Inspect and replace transfer tubes or check valve, as required.
	Poor ventilation	Relocate compressor to an area with cool, dry, well-circulated air, at least 12 inches from nearest wall.
	Dirty cooling surfaces	Clean all cooling surfaces thoroughly.

Reference	Part Number	Part Description	Quantity
15a	512-0041	Bushing, 2" NPT x 1/4" NPT	1
15b	072-0019	Petcock	1
15c	512-0043	Bushing, 2" NPT x 3/4" NPT	1
15d	513-0001	O-ring 2"	2
16	098-3870	Warning label	1
17	098-2856	Warning label	1
18	058-0125	Nut, 5/16-18	4
19	098-3031	Warning label	1
20	059-0362	Bolt, 5/16 x .75"	4
21	026-0735	Interconnect cord	1
22	160-0370	Motor (see capacitor table below)	1
23	125-0232	Belt guard (inner)	1
24	060-0146	Washer, #10	1
25	061-0113	Screw, 10-24 x .50"	1
26	007-0069	Belt	1
27	061-0238	Setscrew	2
28	146-0016	Key	1
29	006-0159	Pulley	1
30	061-0134	Screw, 1/4-20 x 3/4	4
31	060-0144	Washer, 1/4	1
32	125-0233	Belt guard	1
33	103-0205	Fastener	5
35	071-0003	Strain relief, 3/8-90°	1
36	061-0255	Screw, M5 X 20 mm	5
37	060-0156	Washer, #10	8

Capacitors				
	Start capacitor	Start capacitor cover	Run capacitor	Run capacitor cover
Marathon/ Regal Motor Capacitors	166-0222 Marathon/Regal P/N - 81.409.1.23	166-0224 Marathon/Regal P/N - 2506620.003	166-0223 Marathon/Regal P/N - 81.409.2.117	166-0225 Marathon/Regal P/N - 680837-003

Pump Parts Diagram

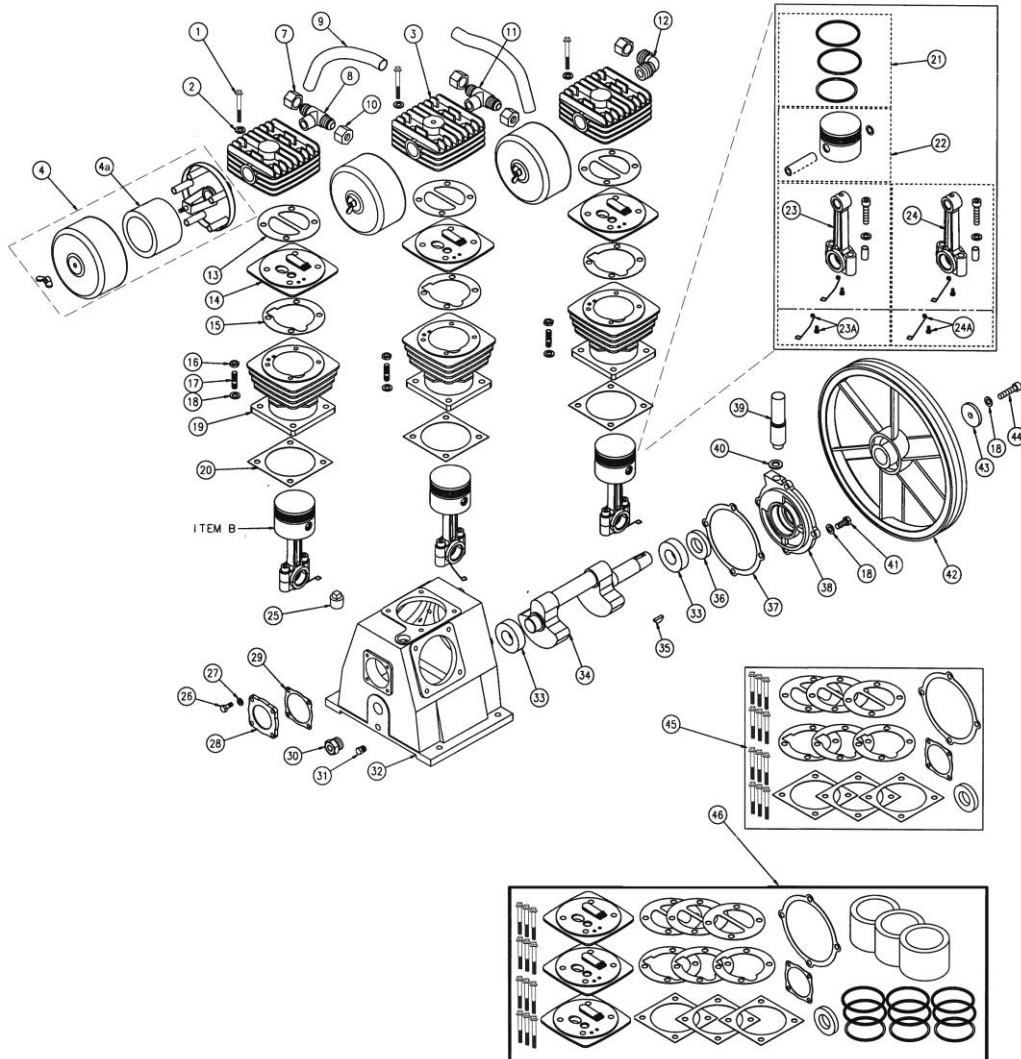

Pump Parts List

Reference	Part Number	Part Description	Quantity
1	059-0412	Screw, M8 x 65	12
2	060-0219	Washer, M8	12
3	042-0117	Head	3
4	019-0222	Filter canister assembly (includes item 4A)	3
4A	019-0221	Element, filter replacement	3
7	058-0016	Compression nut	1
8	069-0025	Tee fitting	1
9	145-0447	Finned tube (includes item 10)	2
10	N/A	Airflow nut (included on item 9)	4
11	069-0024	Tee fitting	1
12	064-0077	Elbow	1
13	046-0286	Gasket, head to valve plate	3

Reference	Part Number	Part Description	Quantity
14	043-0194	Valve plate assembly (includes items 13 and 15)	3
15	046-0287	Gasket, valve plate to cylinder	3
16	058-0188	Nut, M8	12
17	059-0413	Stud, M8*22	12
18	060-0222	Lock washer, M8	23
19	050-0062	Cylinder	3
20	046-0288	Gasket, cylinder to crankcase	3
21	054-0241	Ring set	3
22	048-0117	Piston assembly	3
23	047-0094	Rod (middle)	1
23A	056-0068	Oil dipper, straight	1
24	047-0095	Rod (outer)	2
24A	056-0069	Oil dipper, bend	2
25	056-0070	Oil fill plug	1
26	059-0414	Screw, M6 x 18	4
27	060-0220	Lock washer, M6	4
28	077-0180	Cap, rear end	1
29	046-0289	Gasket, rear end	1
30	032-0125	Oil sight glass with O-ring	1
31	062-0075	Oil drain plug, 3/8" NPT	1
32	049-0051	Crankcase	1
33	051-0100	Bearing	2
34	053-0105	Crankshaft, extended	1
35	146-0026	Key, 5 MM x 20 MM	1
36	046-0290	Oil seal	1
37	046-0291	Gasket, carrier	1
38	077-0181	Carrier	1
39	056-0096	Breather (includes item 40)	1
40	060-0221	Breather washer, 22MM dia.	1
41	059-0415	Screw, M8 x 20	4
42 **	044-0063	Flywheel, 12" A groove	1
43 **	060-0183	Flywheel washer	1
44 **	059-0416	Screw, M8 x 35	1
45	046-0292	Gaskets, complete set (includes items 1, 13, 15, 20, 29, 36 and 37)	1
46	165-0265	Overhaul kit (includes items 1, 14, 20, 21, 29, 36, 37 and 4A)	1
	040-0348	Pump assembly (includes items 1-41)	1

** Must be purchased separately

Switch Assembly Parts Diagram

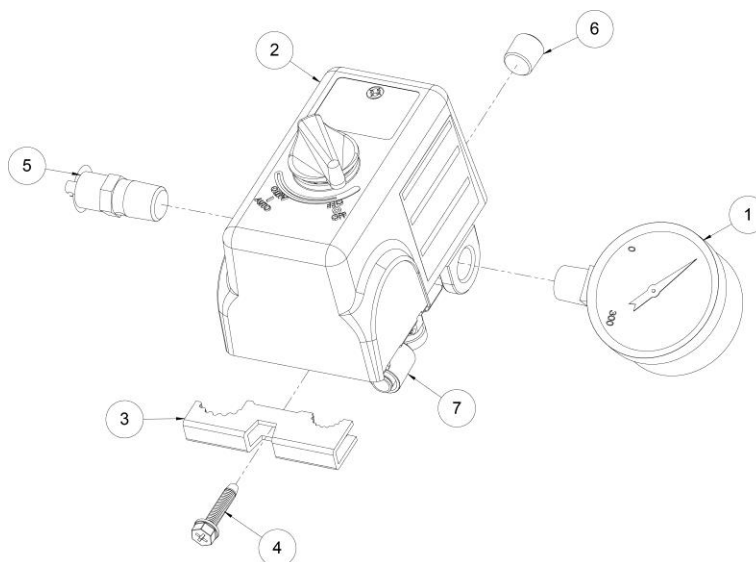

Switch Assembly Parts List

Reference	Part Number	Part Description	Quantity
1	032-0025	Gauge, 300# 1/4" bottom connect	1
2	034-0184	Switch, pressure 155 PSI (includes items 3-4 and 6-7)	1
3	071-0033	Strain relief	1
4	061-0216	Screw	1
5	136-0077	Valve, ASME	1
6	062-0035	Plug, 1/4"	1
7	136-0090	Valve, bleeder	1

Replacement Parts

- For replacement parts and technical questions, please call Customer Service at 1-888-895-4549.
- Not all product components are available for replacement. The illustrations provided are a convenient reference to the location and position of parts in the assembly sequence.
- When ordering parts, the following information will be required: item description, item model number, item serial number/item lot date code, and the replacement part reference number.
- The distributor reserves the rights to make design changes and improvements to product lines and manuals without notice.

Limited Warranty

Dear Valued Customer:

The NorthStar® Product you just purchased is built with the finest material and craftsmanship. Use this product properly and enjoy the benefits from its high performance. By purchasing a NorthStar® product, you show a desire for quality and durability. Like all mechanical equipment, this unit requires a due amount of care. Treat this unit like the high-quality piece of machinery it is. Neglect and improper handling may impair its performance. Please thoroughly read the instructions and understand the operation before using your product. Always contact NorthStar® Product Support at 1-888-895-4549 prior to having any service or warranty work performed, as some services performed by parties other than NorthStar® approved service centers may void this warranty. This warranty is in lieu of any other warranty expressed or implied and NorthStar® assumes no other responsibility or liability outside that expressed within this warranty.

Limited Warranty

NorthStar® shall warranty any piece of equipment manufactured, or parts of equipment manufactured, to be free from defects in material or workmanship for a period of:

NorthStar® Warranty		
Item	Consumer Warranty Period	Commercial Warranty Period
#75710	4 years from date of purchase by user	2 years from date of purchase by user

“Consumer use” means personal residential household use by a consumer. “Commercial use” means all other uses, including use for commercial, income producing, or rental purposes or when purchased by a business.

This warranty applies to the original purchaser of the equipment (verification of purchase, in the form of a receipt, is the responsibility of the buyer), is non-transferable, and covers parts and labor. Parts will be replaced or repaired at no charge, except when the equipment has failed due to lack of proper maintenance. If a part is no longer available, the part may be replaced with a similar part of equal function. Any misuse, abuse, alteration, or improper installation or operations will void warranty. Determining whether a part is to be replaced or repaired is the sole decision of NorthStar®. NorthStar® will not provide for replacement of complete products due to defective parts. Any costs incurred due to replacement or repair of items outside of a NorthStar® approved facility is the responsibility of the buyer and not covered under warranty. Transportation costs to and from the service center is the responsibility of the customer. For technical repairs, a service center may be dispatched to conduct the repair on-site.

In addition to the normal warranty, NorthStar® shall warrant any normal wear item from defects in material or workmanship for a period of 90 days from the date of purchase by user. Normal wear items include, but are not limited to, belts, sheaves, flywheels, check valves, pressure switches, air unloaders, throttle controls, electric motors, brushes, regulators, O-rings, pressure gauges, tubing, piping, fittings, fasteners, wheels, quick couplers, gaskets, seals, air filter housings, piston rings, connecting rods, and piston seals.

This warranty specifically excludes the following items: routine maintenance items such as oil, lubricants, and air filters, as well as changing oil, air filters, belt tensioning, etc., fall under the owner’s responsibility. Additional exclusions include: freight damage, failures resulting from neglect, accident, or abuse, induction motors when operated from a generator, oil leaks, air leaks, oil consumption, leaky fittings, hoses, petcocks, bleeder tubes, and transfer tubes. Additional exclusions include: loss of running time, inconvenience, loss of income, or loss of use. Additional exclusions include: failure of parts due to damage caused by accident, fire, flood, windstorm, or acts of God, Applications not approved by NorthStar® in writing, corrosion caused by

chemicals, use of replacement parts which do not conform to manufacturer's specifications, and damage related to rodent and/or insect infestation and damage caused by vandalism.

EXCEPT AS PROVIDED HEREIN, NORTHSTAR® BY AND THROUGH ITS OWNER NORTHERN TOOL & EQUIPMENT COMPANY, INC. ("NTE") HEREBY DISCLAIMS ALL WARRANTIES (WHETHER EXPRESS, STATUTORY, OR IMPLIED) INCLUDING WITHOUT LIMITATION THE IMPLIED WARRANTIES OF MERCHANTABILITY, FITNESS FOR A PARTICULAR PURPOSE, AND NON-INFRINGEMENT. YOU AGREE THAT YOUR SOLE AND EXCLUSIVE REMEDY UNDER THIS LIMITED WARRANTY SHALL BE THE REPAIR OR REPLACEMENT OF YOUR NORTHSTAR® PRODUCT, AT NTE'S DISCRETION. NTE SHALL NOT BE LIABLE FOR ANY SPECIAL, INCIDENTAL, CONSEQUENTIAL, DIRECT, INDIRECT, OR PUNITIVE DAMAGES ARISING OUT OF YOUR USE OF THE NORTHSTAR® PRODUCT.

You should also be aware of the following:

- Repairs requiring overtime, weekend rates, or any other charges beyond the standard shop labor rate are not covered.
- Time required for orientation training for the service center to gain access to the product, or additional time due to inadequate egress.
- Damage caused by incorrect voltage, improperly wired, or failure to have a certified licensed electrician install the compressor, will render this warranty null and void.
- Damage caused from inadequate filter maintenance.
- Pump wear or valve damage caused by using oil not specified.
- Pump wear or damage caused by any oil contamination.
- Pump wear or valve damage caused by failure to follow proper maintenance guidelines.
- Operation below proper oil level or operation without oil.
- Power Equipment needs periodic parts and service to perform well, and this warranty does not cover instances when normal use has exhausted the life of a component or the motor.

This warranty does not cover any personal injury or damage to surrounding property caused by failure of any part. Repair or replacement of parts does not extend the warranty period.

Please fill in the following information and have it on hand when you call for a warranty claim.

Customer Number: _____

Date of Purchase: _____

NorthStar® Serial Number: _____

Item Number: _____



Distributed by:

Northern Tool & Equipment Company, Inc.

Burnsville, Minnesota 55306

www.northerntool.com

Made in U.S.A. of Domestic and Foreign Parts

200-3153-A_5-2-19