



OM-281997G

2024-03

# Inventor<sup>™</sup> Series

## Auto-Darkening Welding Helmets

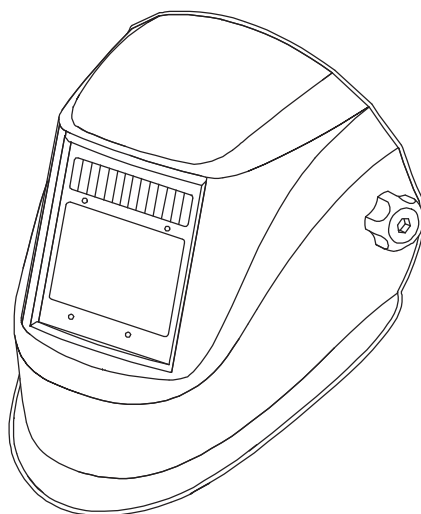

**OWNER'S MANUAL**

# TABLE OF CONTENTS

<b>SECTION 1 – SAFETY PRECAUTIONS – READ BEFORE USING</b> .....	<b>1</b>
1-1 Symbol Usage .....	1
1-2 Arc Welding Hazards .....	1
1-3 California Proposition 65 Warnings .....	3
1-4 Lens Shade Selection Table .....	3
1-5 Principal Safety Standards .....	4
<b>SECTION 2 – CONSIGNES DE SÉCURITÉ - LIRE AVANT UTILISATION</b> .....	<b>5</b>
2-1 Symboles utilisés .....	5
2-2 Dangers concernant le soudage à l'arc .....	5
2-3 Proposition californienne 65 Avertissements .....	8
2-4 Tableau de sélection du vignettage .....	8
2-5 Principales normes de sécurité .....	9
<b>SECTION 3 – SPECIFICATIONS</b> .....	<b>10</b>
<b>SECTION 4 – OPERATION</b> .....	<b>11</b>
4-1 Helmet Controls .....	11
4-2 Low Battery Indicator .....	11
4-3 Lens Delay Control .....	12
4-4 Variable Shade Control (No. 9–13) .....	12
4-5 Sensitivity Control .....	13
4-6 Weld/Grind Mode Switch .....	14
4-7 Power Modes .....	14
<b>SECTION 5 – ADJUSTING HEADGEAR</b> .....	<b>15</b>
5-1 Adjusting Headgear .....	15
<b>SECTION 6 – REPLACING LENS COVERS</b> .....	<b>16</b>
6-1 Replacing Outside Lens Cover .....	16
6-2 Replacing Inside Lens Cover .....	17
<b>SECTION 7 – REPLACING THE BATTERY</b> .....	<b>18</b>
7-1 Replacing The Battery .....	18
<b>SECTION 8 – INSTALLING OPTIONAL MAGNIFYING LENS</b> .....	<b>19</b>
8-1 Installing Optional Magnifying Lens .....	19
<b>SECTION 9 – MAINTENANCE AND TROUBLESHOOTING</b> .....	<b>20</b>
9-1 Maintenance And Storage .....	20
9-2 Troubleshooting .....	21
<b>SECTION 10 – PARTS LIST</b> .....	<b>22</b>
<b>SECTION 11 – LIMITED WARRANTY</b> .....	<b>23</b>

# SECTION 1 – SAFETY PRECAUTIONS – READ BEFORE USING

-  Protect yourself and others from injury—read, follow, and save these important safety precautions and operating instructions.

## 1-1. Symbol Usage

-  **DANGER!** – Indicates a hazardous situation which, if not avoided, will result in death or serious injury. The possible hazards are shown in the adjoining symbols or explained in the text.

-  Indicates a hazardous situation which, if not avoided, could result in death or serious injury. The possible hazards are shown in the adjoining symbols or explained in the text.

**NOTICE** – Indicates statements not related to personal injury.

 Indicates special instructions.



This group of symbols means Warning! Watch Out! ELECTRIC SHOCK, MOVING PARTS, and HOT PARTS hazards. Consult symbols and related instructions below for necessary actions to avoid these hazards.

## 1-2. Arc Welding Hazards

-  The symbols shown below are used throughout this manual to call attention to and identify possible hazards. When you see the symbol, watch out, and follow the related instructions to avoid the hazard. The safety information given below is only a summary of the more complete safety information found in the Principal Safety Standards. Read and follow all Safety Standards.

-  Only qualified persons should install, operate, maintain, and repair this equipment. A qualified person is defined as one who, by possession of a recognized degree, certificate, or professional standing, or who by extensive knowledge, training and experience, has successfully demonstrated the ability to solve or resolve problems relating to the subject matter, the work, or the project and has received safety training to recognize and avoid the hazards involved.

-  During operation, keep everybody, especially children, away.



### ARC RAYS can burn eyes and skin.

Arc rays from the welding process produce intense visible and invisible (ultra-violet and infrared) rays that can burn eyes and skin. Sparks fly off from the weld.

- Wear a welding helmet fitted with a proper shade of filter to protect your face and eyes when welding or watching (see ANSI Z49.1 and Z87.1 listed in Principal Safety Standards). Refer to Lens Shade Selection table in Section 1-4.
- Wear approved safety glasses with side shields under your helmet.
- Use protective screens or barriers to protect others from flash, glare, and sparks; warn others not to watch the arc.
- Wear body protection made from leather or flame-resistant clothing (FRC). Body protection includes oil-free clothing such as leather gloves, heavy shirt, cuffless trousers, high shoes, and a cap.

- Before welding, adjust the auto-darkening lens sensitivity setting to meet the application.
- Stop welding immediately if the auto-darkening lens does not darken when the arc is struck.

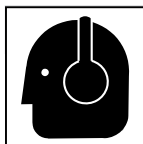

### **NOISE can damage hearing.**

Noise from some processes or equipment can damage hearing.

- Wear approved ear protection if noise level is high.



### **WELDING HELMETS do not provide unlimited eye, ear, and face protection.**

Arc rays from the welding process produce intense visible and invisible (ultra-violet and infrared) rays that can burn eyes and skin. Sparks fly off from the weld.

- Use helmet for welding/cutting applications only. Do not use helmet for laser welding/cutting.
- Use impact resistant safety spectacles or goggles and ear protection at all times when using this welding helmet.
- Do not use this helmet while working with or around explosives or corrosive liquids.
- This helmet is not rated for overhead welding. Do not weld in the direct overhead position while using this helmet unless additional precautions are taken to protect yourself from arc rays, spatter, and other hazards.
- Inspect the auto-lens frequently. Immediately replace any scratched, cracked, or pitted cover lenses or auto-lenses.
- Lens and retention components must be installed as instructed in this manual to ensure compliance with ANSI Z87.1 protection standards.
- This helmet provides protection from projectiles associated with grinding, chipping, and related activities; it is not a hard hat and does not provide protection from falling objects.

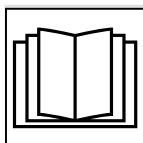

### **READ INSTRUCTIONS.**

- Read and follow all labels and the Owner's Manual carefully before installing, operating, or servicing unit. Read the safety information at the beginning of the manual and in each section.
- Use only genuine replacement parts from the manufacturer.
- Perform installation, maintenance, and service according to the Owner's Manuals, industry standards, and national, state, and local codes.

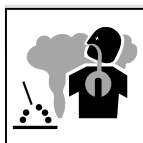

### **FUMES AND GASES can be hazardous.**

Welding produces fumes and gases. Breathing these fumes and gases can be hazardous to your health.

- Keep your head out of the fumes. Do not breathe the fumes.
- Ventilate the work area and/or use local forced ventilation at the arc to remove welding fumes and gases. The recommended way to determine adequate ventilation is to sample for the composition and quantity of fumes and gases to which personnel are exposed.
- If ventilation is poor, wear an approved air-supplied respirator.
- Read and understand the Safety Data Sheets (SDSs) and the manufacturer's instructions for adhesives, coatings, cleaners, consumables, coolants, degreasers, fluxes, and metals.
- Work in a confined space only if it is well ventilated, or while wearing an air-supplied respirator. Always have a trained watchperson nearby. Welding fumes and gases can displace air and lower the oxygen level causing injury or death. Be sure the breathing air is safe.

- Do not weld in locations near degreasing, cleaning, or spraying operations. The heat and rays of the arc can react with vapors to form highly toxic and irritating gases.
- Do not weld on coated metals, such as galvanized, lead, or cadmium plated steel, unless the coating is removed from the weld area, the area is well ventilated, and while wearing an air-supplied respirator. The coatings and any metals containing these elements can give off toxic fumes if welded.



**INGESTION HAZARD: This product contains a button cell or coin battery.**

Death or serious injury can occur if ingested.

- A swallowed button cell or coin battery can cause Internal Chemical Burns in as little as 2 hours.
- Keep new and used batteries out of reach of children.
- Always completely secure the battery compartment. If the battery compartment does not close securely, stop using the product, remove the batteries, and keep them away from children.
- Seek immediate medical attention if a battery is suspected to be swallowed or inserted inside any part of the body.
- Call a local poison control center for treatment information.
- Remove and immediately recycle or dispose of used batteries according to local regulations and keep away from children. Do NOT dispose of batteries in household trash or incinerate.
- Remove and immediately recycle or dispose of batteries from equipment not used for an extended period of time according to local regulations.
- Even used batteries can cause severe injury or death.



**BATTERY MISUSE can injure.**

- Non-rechargeable batteries are not to be recharged.
- Do not force discharge, recharge, disassemble, heat above 131°F (55°C), or incinerate. Doing so may result in injury due to venting, leakage, or explosion resulting in chemical burns.
- Ensure the batteries are installed correctly according to polarity (+ and –).
- Do not mix old and new batteries, different brands or types of batteries, such as alkaline, carbon-zinc, or rechargeable batteries.

**1-3. California Proposition 65 Warnings**

**WARNING – Cancer and Reproductive Harm — [www.P65Warnings.ca.gov](http://www.P65Warnings.ca.gov).**

**1-4. Lens Shade Selection Table**

Process	Electrode Size in. (mm)	Arc Current in Amperes	Minimum Protective Shade No.	Suggested Shade No. (Comfort)*
Shielded Metal Arc Welding (SMAW)	Less than 3/32 (2.4)	Less than 60	7	--
	3/32-5/32 (2.4-4.0)	60–160	8	10
	5/32-1/4 (4.0-6.4)	160–250	10	12
	More than 1/4 (6.4)	250–550	11	14
Gas Metal Arc Welding (GMAW)		Less than 60	7	--
		60–160	10	11
		160–250	10	12

Process	Electrode Size in. (mm)	Arc Current in Amperes	Minimum Protective Shade No.	Suggested Shade No. (Comfort)*
Flux Cored Arc Welding (FCAW)		250–500	10	14
Gas Tungsten Arc Welding (TIG)		Less than 50	8	10
		50–150	8	12
		150–500	10	14
Air Carbon Arc Cutting (CAC-A)	Light	Less than 500	10	12
	Heavy	500–1000	11	14
Plasma Arc Cutting (PAC)		Less than 20	4	4
		20–40	5	5
		40–60	6	6
		60–80	8	8
		80–300	8	9
		300–400	9	12
		400–800	10	14
Plasma Arc Welding (PAW)		Less than 20	6	6–8
		20–100	8	10
		100–400	10	12
		400–800	11	14

Reference: ANSI Z49.1:2021

\*Start with a shade that is too dark to see the weld zone. Then, go to a lighter shade which gives a sufficient view of the weld zone without going below the minimum.

## 1-5. Principal Safety Standards

*Safety in Welding, Cutting, and Allied Processes*, American Welding Society standard ANSI Standard Z49.1. Website: [www.aws.org](http://www.aws.org).

*Safe Practice For Occupational And Educational Eye And Face Protection*, ANSI Standard Z87.1, from American National Standards Institute. Website: [safetyequipment.org](http://safetyequipment.org).

*Safety in Welding, Cutting, and Allied Processes*, CSA Standard W117.2 from Canadian Standards Association. Website: [www.csagroup.org](http://www.csagroup.org).

*Industrial Head Protection*, ANSI/ISEA Standard Z89.1 from American National Standards Institute. Website: [safetyequipment.org](http://safetyequipment.org).

*Australian National Work Health Safety Policy* from Safe Work Australia. Website: [www.safework-australia.com](http://www.safework-australia.com).

*Safety in Welding and Allied Processes*, AS1674.1 and AS1674.2 part 1 and 2 from SAI Global. Website: [www.saiglobal.com](http://www.saiglobal.com).

*Standard for Safety: Products Incorporating Button Batteries or Coin Cell Batteries*, ANSI/UL 4200A. Website: [www.ul.com](http://www.ul.com).

Helmet 2024–01

# SECTION 2 – CONSIGNES DE SÉCURITÉ - LIRE AVANT UTILISATION

-  Pour écarter les risques de blessure pour vous-même et pour autrui — lire, appliquer et ranger en lieu sûr ces consignes relatives aux précautions de sécurité et au mode opératoire.

## 2-1. Symboles utilisés

-  **DANGER!** – Indique une situation dangereuse qui si on l'évite pas peut donner la mort ou des blessures graves. Les dangers possibles sont montrés par les symboles joints ou sont expliqués dans le texte.

-  Indique une situation dangereuse qui si on l'évite pas peut donner la mort ou des blessures graves. Les dangers possibles sont montrés par les symboles joints ou sont expliqués dans le texte.

**AVIS** – Indique des déclarations pas en relation avec des blessures personnelles.

 Indique des instructions spécifiques.



Ce groupe de symboles veut dire Avertissement! Attention! DANGER DE CHOC ELECTRIQUE, PIECES EN MOUVEMENT, et PIECES CHAUDES. Reportez-vous aux symboles et aux directives ci-dessous afin de connaître les mesures à prendre pour éviter tout danger.

## 2-2. Dangers concernant le soudage à l'arc

-  Les symboles représentés ci-dessous sont utilisés dans ce manuel pour attirer l'attention et identifier les dangers possibles. En présence de ce symbole, prendre garde et suivre les instructions afférentes pour éviter tout risque. Les consignes de sécurité présentées ci-après ne font que résumer l'information contenue dans les Normes de sécurité principales. Lire et suivre toutes les Normes de sécurité.

-  L'installation, l'utilisation, l'entretien et les réparations ne doivent être confiés qu'à des personnes qualifiées. Une personne qualifiée est définie comme celle qui, par la possession d'un diplôme reconnu, d'un certificat ou d'un statut professionnel, ou qui, par une connaissance, une formation et une expérience approfondies, a démontré avec succès sa capacité à résoudre les problèmes liés à la tâche, le travail ou le projet et a reçu une formation en sécurité afin de reconnaître et d'éviter les risques inhérents.

-  Au cours de l'utilisation, tenir toute personne à l'écart et plus particulièrement les enfants.



### LES RAYONS DE L'ARC peuvent provoquer des brûlures des yeux et de la peau.

Le rayonnement de l'arc du procédé de soudage génère des rayons visibles et invisibles intenses (ultraviolets et infrarouges) susceptibles de provoquer des brûlures des yeux et de la peau. Des étincelles sont projetées pendant le

soudage.

- Porter un casque de soudage muni d'un écran de filtre approprié pour protéger votre visage et vos yeux pendant le soudage ou pour regarder (voir ANSI Z49.1 et Z87.1 énumérés dans les principales normes de sécurité). Voir le tableau Sélection du vignettage à la section 2-4.
- Porter des protections approuvées pour les oreilles si le niveau sonore est trop élevé.

- Avoir recours à des écrans protecteurs ou à des rideaux pour protéger les autres contre les rayonnements les éblouissements et les étincelles ; prévenir toute personne sur les lieux de ne pas regarder l'arc.
- Porter une protection corporelle en cuir ou des vêtements ignifuges (FRC). La protection du corps comporte des vêtements sans huile, comme des gants de cuir, une chemise solide, des pantalons sans revers, des chaussures hautes et une casquette.
- Avant le soudage, ajuster le réglage de la sensibilité de la lentille auto-obscurcissante en fonction de l'application.
- Arrêter immédiatement le soudage si la lentille auto-obscurcissante ne s'obscurcit pas lorsque l'arc est frappé.

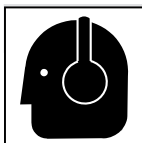

### **Le BRUIT peut endommager l'ouïe.**

Le bruit des processus et des équipements peut affecter l'ouïe.

- Porter des protections approuvées pour les oreilles si le niveau sonore est trop élevé.



### **Les CASQUES DE SOUDAGE ne fournissent pas une protection illimitée des yeux, des oreilles et du visage.**

Le rayonnement de l'arc du procédé de soudage génère des rayons visibles et invisibles intenses (ultraviolets et infrarouges) susceptibles de provoquer des brûlures dans les yeux et sur la peau. Des étincelles sont projetées pendant le

soudage.

- Porter un casque pour les applications de soudure/coupe seulement. Ne pas utiliser le casque pour souder/découper au laser.
- Porter des lunettes de sécurité et des protecteurs antibruit résistants aux chocs en tout temps pendant l'utilisation de ce casque de soudage.
- Ne pas utiliser ce casque de soudage pendant la manutention ou le travail à proximité de liquides explosifs ou corrosifs.
- Ce casque n'est pas évalué pour le soudage à la verticale. Ne pas souder dans une position directement à la verticale tout en utilisant ce casque à moins d'avoir pris des précautions supplémentaires au préalable afin de se protéger contre les rayonnements de l'arc, des projections et d'autres risques.
- Vérifier fréquemment l'état de la cellule à obscurcissement automatique. Remplacer immédiatement toute loupe ou cellule égratignée, fissurée ou piquée.
- La lentille et les composants de rétention doivent être installés conformément aux instructions de ce manuel pour garantir la conformité aux normes de protection ANSIZ87.1.
- Ce casque offre une protection contre les projectiles associés au broyage, à l'écaillage et aux activités; il ne s'agit pas d'un casque de sécurité, et celui-ci ne protège pas contre les chutes d'objets.

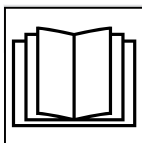

### **LIRE LES INSTRUCTIONS.**

- Lire et appliquer les instructions sur les étiquettes et le Mode d'emploi avant l'installation, l'utilisation ou l'entretien de l'appareil. Lire les informations de sécurité au début du manuel et dans chaque section.
- N'utiliser que des pièces de remplacement provenant du fabricant.
- Effectuer l'installation, l'entretien et toute intervention selon les manuels d'utilisateurs, les normes nationales, provinciales et de l'industrie, ainsi que les codes municipaux.

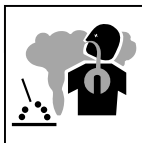

## LES FUMÉES ET LES GAZ peuvent être dangereux.

Le soudage génère des fumées et des gaz. Leur inhalation peut être dangereuse pour votre santé.

- Eloigner votre tête des fumées. Ne pas respirer les fumées.
- À l'intérieur, ventiler la zone et/ou utiliser une ventilation forcée au niveau de l'arc pour l'évacuation des fumées et des gaz de soudage. Pour déterminer la bonne ventilation, il est recommandé de procéder à un prélèvement pour la composition et la quantité de fumées et de gaz auxquelles est exposé le personnel.
- Si la ventilation est médiocre, porter un respirateur anti-vapeurs approuvé.
- Lire et comprendre les fiches de données de sécurité et les instructions du fabricant concernant les adhésifs, les revêtements, les nettoyants, les consommables, les produits de refroidissement, les dégraissages, les flux et les métaux.
- Travailler dans un espace fermé seulement s'il est bien ventilé ou en portant un respirateur à alimentation d'air. Demander toujours à un surveillant dûment formé de se tenir à proximité. Des fumées et des gaz de soudage peuvent déplacer l'air et abaisser le niveau d'oxygène provoquant des blessures ou des accidents mortels. S'assurer que l'air de respiration ne présente aucun danger.
- Ne pas souder dans des endroits situés à proximité d'opérations de dégraissage, de nettoyage ou de pulvérisation. La chaleur et les rayons de l'arc peuvent réagir en présence de vapeurs et former des gaz hautement toxiques et irritants.
- Ne pas souder des métaux munis d'un revêtement, tels que l'acier galvanisé, plaqué en plomb ou au cadmium à moins que le revêtement n'ait été enlevé dans la zone de soudure, que l'endroit soit bien ventilé, et en portant un respirateur à alimentation d'air. Les revêtements et tous les métaux renfermant ces éléments peuvent dégager des fumées toxiques en cas de soudage.



## RISQUE D'INGESTION : Ce produit contient une pile bouton ou une pile au lithium.

La mort ou des blessures graves peuvent survenir en cas d'ingestion.

- L'ingestion d'une pile bouton ou une pile au lithium peut provoquer des brûlures chimiques internes en seulement 2 heures.
- Gardez les piles neuves et usagées hors de portée des enfants.
- Sécurisez toujours complètement le compartiment à piles. Si le compartiment à piles ne se ferme pas correctement, arrêtez d'utiliser le produit, retirez les piles et gardez-les hors de portée des enfants.
- Consultez immédiatement un médecin si vous soupçonnez qu'une pile a été avalée ou insérée dans une partie du corps.
- Appelez le centre antipoison local pour obtenir des informations sur le traitement à suivre.
- Retirez et recyclez ou jetez immédiatement les piles usagées conformément aux réglementations locales et gardez-les hors de portée des enfants. Ne jetez PAS les piles avec les ordures ménagères ou ne les incinerez pas.
- Retirez et recyclez ou jetez immédiatement les piles des équipements non utilisés pendant une période prolongée, conformément aux réglementations locales.
- Même les piles usagées peuvent provoquer des blessures graves, voire la mort.



## UNE MAUVAISE UTILISATION DE LA PILE peut blesser

- Les piles non rechargeables ne doivent pas être rechargées.

- Ne forcez pas la décharge, la recharge, le démontage, la chaleur au-dessus de 131 °F (55 °C) et l'incinération. Cela pourrait entraîner des blessures dues à une ventilation, une fuite ou une explosion entraînant des brûlures chimiques.
- Assurez-vous que les piles sont installées correctement selon la polarité (+ et –).
- Ne mélangez pas des piles anciennes et neuves, de marques ou de types de piles différents, tels que des piles alcalines, carbone-zinc ou rechargeables.

### 2-3. Proposition californienne 65 Avertissements

 **AVERTISSEMENT – Cancer et troubles de la reproduction — [www.P65Warnings.ca.gov](http://www.P65Warnings.ca.gov).**

### 2-4. Tableau de sélection du vignettage

Procédé	Taille d'électrode in. (mm)	Courant d'arc en ampères	N° de classe de protection minimum	Classe de protection suggérée (Comfort)*
Soudage à l'arc métallique avec électrode enrobée (SMAW)	Moins de 3/32 (2,4)	Moins de 60	7	--
	3/32-5/32 (2,4-4,0)	60–160	8	10
	5/32-1/4 (4,0-6,4)	160–250	10	12
	Plus de 1/4 (6,4)	250–550	11	14
Soudage à l'arc MIG/MAG Soudage fil fourré (FCAW)		Moins de 60	7	--
		60–160	10	11
		160–250	10	12
		250–500	10	14
Soudage à l'arc avec électrode en tungstène sous gaz inerte (TIG)		Moins de 50	8	10
		50–150	8	12
		150–500	10	14
Coupage arc-air (CAC-A)	Léger	Moins de 500	10	12
	Lourd	500–1000	11	14
Coupage à l'arc plasma		Moins de 20	4	4
		20–40	5	5
		40–60	6	6
		60–80	8	8
		80–300	8	9
		300–400	9	12
		400–800	10	14
Soudage à l'arc plasma (PAW)		Moins de 20	6	6–8
		20–100	8	10
		100–400	10	12
		400–800	11	14

Référence: ANSI Z49.1:2021

\*Commencer par une classe de protection trop foncée pour voir la zone de soudage. Ensuite, passer à une classe de protection plus claire, permettant de voir suffisamment la zone de soudage sans aller sous le seuil minimum.

## 2-5. Principales normes de sécurité

*Safety in Welding, Cutting, and Allied Processes*, American Welding Society standard ANSI Standard Z49.1. Website: [www.aws.org](http://www.aws.org).

*Safe Practice For Occupational And Educational Eye And Face Protection*, ANSI Standard Z87.1, from American National Standards Institute. Website: [safetyequipment.org](http://safetyequipment.org).

*Safety in Welding, Cutting, and Allied Processes*, CSA Standard W117.2 from Canadian Standards Association. Website: [www.csagroup.org](http://www.csagroup.org).

*Industrial Head Protection*, ANSI/ISEA Standard Z89.1 from American National Standards Institute. Website: [safetyequipment.org](http://safetyequipment.org).

*Australian National Work Health Safety Policy* from Safe Work Australia. Website: [www.safework-kaustralia.com](http://www.safework-kaustralia.com).

*Safety in Welding and Allied Processes*, AS1674.1 and AS1674.2 part 1 and 2 from SAI Global. Website: [www.saiglobal.com](http://www.saiglobal.com).

*Standard for Safety: Products Incorporating Button Batteries or Coin Cell Batteries*, ANSI/UL 4200A. Website: [www.ul.com](http://www.ul.com).

Helmet\_fre 2024-01

## SECTION 3 – SPECIFICATIONS

Viewing Field	3.94 x 2.36 in. (100 x 60 mm)
Reaction Time	0.00004 sec (1/25,000 sec)
Available Shades	Darkened State: No. 9–13/Light State: No. 3 Provides Continuous UV And IR Protection (DIN 15)
Grind Mode	Yes
Sensitivity Control	Lo-Hi Adjustment For Varying Ambient Light And Welding Arc
Delay Control	Min-Max Adjustment Slows Lens Dark-To-Light State Between 0.1 And 0.9 Seconds
Power	Auto-On/Auto-Off
Low Battery Indicator	Red LED Light Illuminates To Indicate 2-3 Days Remaining Battery Life
Power Supply	Solar Cell And Two Replaceable CR2450 (3 Volt) Lithium Batteries
Sensors	Independent/Redundant (Four)
Operating Temperature	14°F to 149°F / -10°C to +65°C   <i>When stored in extremely cold temperatures, warm helmet to ambient temperature before welding.</i>
Total Weight	19.7 oz (560 g)
Standards	ANSI Z87.1-2015, CE EN379, CSA Z94.3-15
Warranty	Two Years From Date Of Purchase (see Section 11)

# SECTION 4 – OPERATION

## 4-1. Helmet Controls

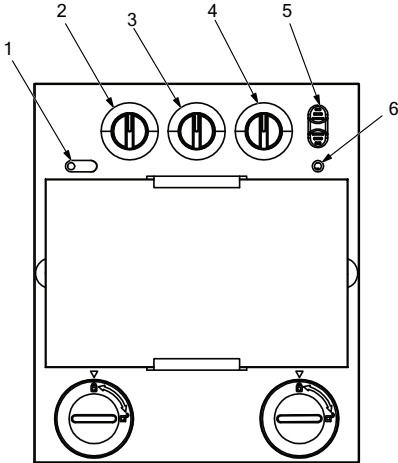

*Remove protective films from lens before welding.*

- 1 Low Battery Indicator (See Section 4-2)
- 2 Variable Shade Control (See Section 4-4)
- 3 Sensitivity Control (See Section 4-5)
- 4 Lens Delay Control (See Section 4-3)
- 5 Weld/Grind Mode Switch (See Section 4-6)
- 6 Grind Mode Indicator (See Section 4-6)

## 4-2. Low Battery Indicator

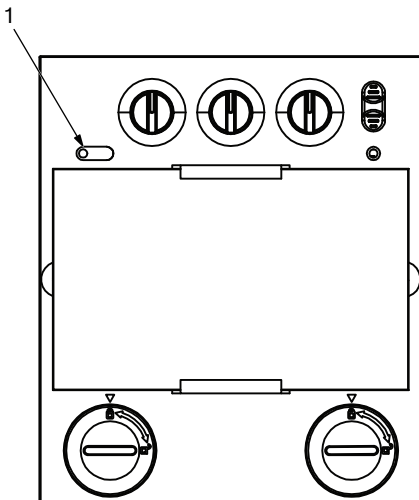

- 1 Low Battery Indicator

The low battery indicator lights when 2-3 days of battery life remain. If battery power is low, install new CR2450 lithium batteries (see Section 7-1).

*The auto-darkening lens consumes less than 1 microamp of battery power when in the sleep mode. See Section 4-7 for more information on battery usage in the different power modes.*

### 4-3. Lens Delay Control

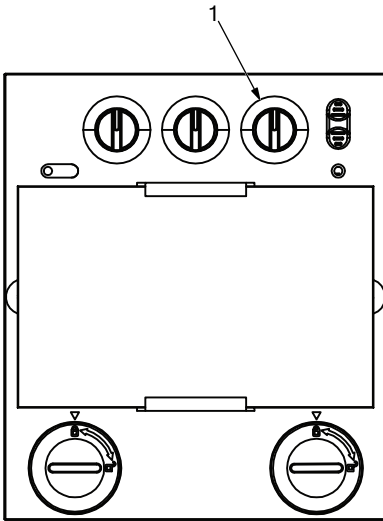
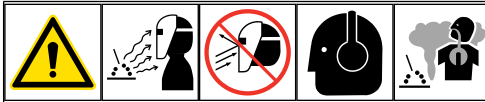

☞ Place Weld/Grind mode switch in Weld position (Section 4-6).

#### 1 Lens Delay Control

The lens delay control is used to adjust the time for the lens to switch to the clear state after welding.

The delay is particularly useful in eliminating bright after-rays present in higher amperage applications where the molten puddle remains bright momentarily after welding. Lens delay adjusts from min (0.1 second) to max (0.9 second).

### 4-4. Variable Shade Control (No. 9–13)

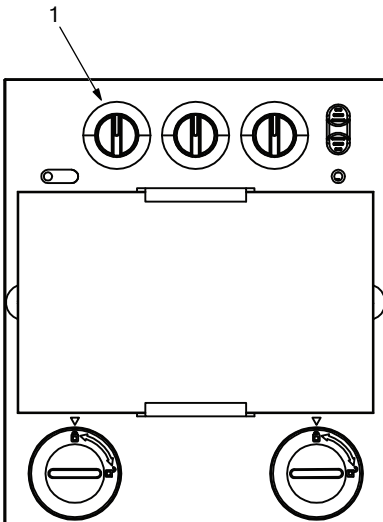

☞ Place Weld/Grind mode switch in Weld position (Section 4-6).

#### 1 Variable Shade Control (No. 9–13)

Use the control to adjust the lens shade in the darkened state. Use the table in Section 1-4 to select proper shade control setting based on your welding process.

Start at the highest setting and adjust lighter to suit the welding application and your personal preference.

## 4-5. Sensitivity Control

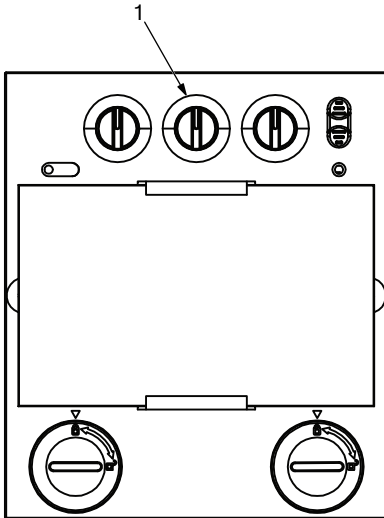
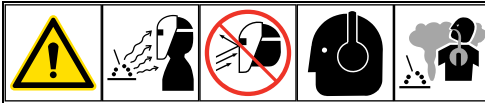

☞ Place Weld/Grind mode switch in Weld position (Section 4-6).

### 1 Sensitivity Control

Use control to make the lens more responsive to different light levels in various welding processes. **Use a Mid-Range or 50-70% sensitivity setting for most applications.**

It may be necessary to adjust helmet sensitivity to accommodate different lighting conditions or if lens is switching on and off. Adjust helmet sensitivity as follows:

☞ Adjust helmet sensitivity in lighting conditions helmet will be used in.

- Before welding (lens in light state), face the helmet in the direction of use. If the lens switches on and off, it is being affected by the surrounding light. Decrease sensitivity setting.
- If lens switches on and off during welding, the sensitivity setting is too low. Increase sensitivity setting. Helmet is now ready for use.

Slight readjustment may be necessary for certain applications or if lens continues to switch on and off.

### Recommended Sensitivity Settings

Stick Electrode	Mid-Range
Short Circuiting (MIG)	Low/Mid-Range
Pulsed And Spray (MIG)	Mid-Range
Gas Tungsten Arc (TIG)	Mid/High-Range
Plasma Arc Cutting/Welding	Low/Mid-Range
Grinding	Place Weld/Grind Mode Switch In Grind Position

#### 4-6. Weld/Grind Mode Switch

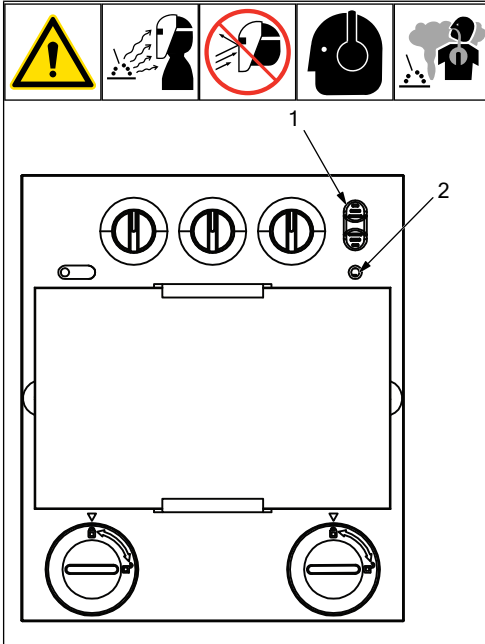

- 1 Weld/Grind Mode Switch
- 2 Grind Mode Indicator

Place switch in Grind mode for grinding applications. To resume welding, place switch in Weld mode. The Grind Mode indicator will blink when helmet is in Grind mode.

 *Do not weld in the Grind mode; the lens will not darken.*

#### 4-7. Power Modes



The auto-darkening lens has three power modes: sleep (off), standby, and on. The lens goes to sleep automatically when ambient light is low (less than 3 lux). The lens consumes less than 1 microamp of battery power when in the sleep mode.

When ambient light exceeds 10 lux, the lens automatically changes to the standby mode and is ready for welding. The lens relies on the solar cell for power when in standby mode.

When welding begins, the lens automatically turns on (darkens). In most cases, the solar cell provides enough power to operate the lens during welding. However, the lens may use both solar and battery power when shade control is at a high setting.

The lens returns to standby mode immediately after welding stops, and then enters sleep mode if ambient lighting is low (less than 3 lux).

# SECTION 5 – ADJUSTING HEADGEAR

## 5-1. Adjusting Headgear

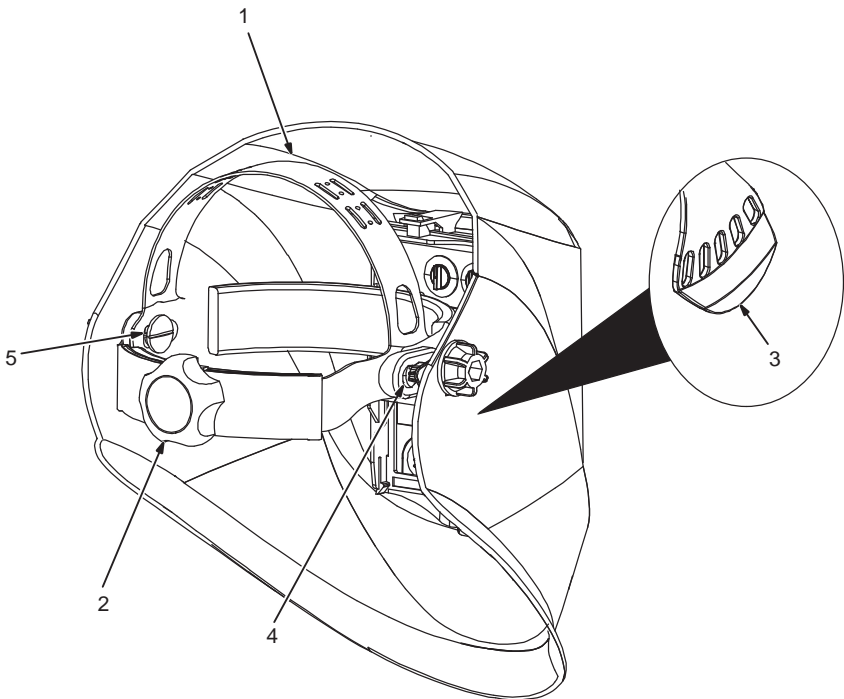
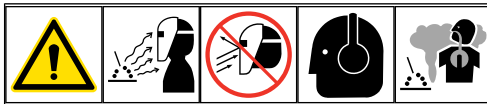

 *There are four headgear adjustments: headgear top, tightness, angle adjustment, and distance adjustment.*

### 1 Headgear Top Adjustment

Adjusts headgear for proper depth on the head to ensure correct balance and stability.

### 2 Headgear Tightness Adjustment

To adjust, turn the adjusting knob located on the back of the headgear left or right to desired tightness.

### 3 Angle Adjustment

Slots on the right side of the headband provide adjustment for the forward tilt of the helmet. To adjust, lift and reposition the control arm to the desired position.

### 4 Distance Adjustment

### 5 Headgear Screw

Adjusts the distance between the face and the lens. To adjust, loosen headgear screws and slide headgear forward or backward to one of the three slots on the slider. Tighten screws. (Both sides must be equally positioned for proper vision.)

# SECTION 6 – REPLACING LENS COVERS

## 6-1. Replacing Outside Lens Cover



**⚠** Never use the auto-darkening lens without the inside and outside lens covers properly installed. Welding spatter will damage the auto-darkening lens and void the warranty.

- 1 Locking Tab
- 2 Lens Assembly
- 3 Outside Lens Cover

Remove lens assembly by sliding the locking tab to the left. Remove cartridge and lens cover.

Install new lens cover. Install lens assembly and slide locking tab to the right.

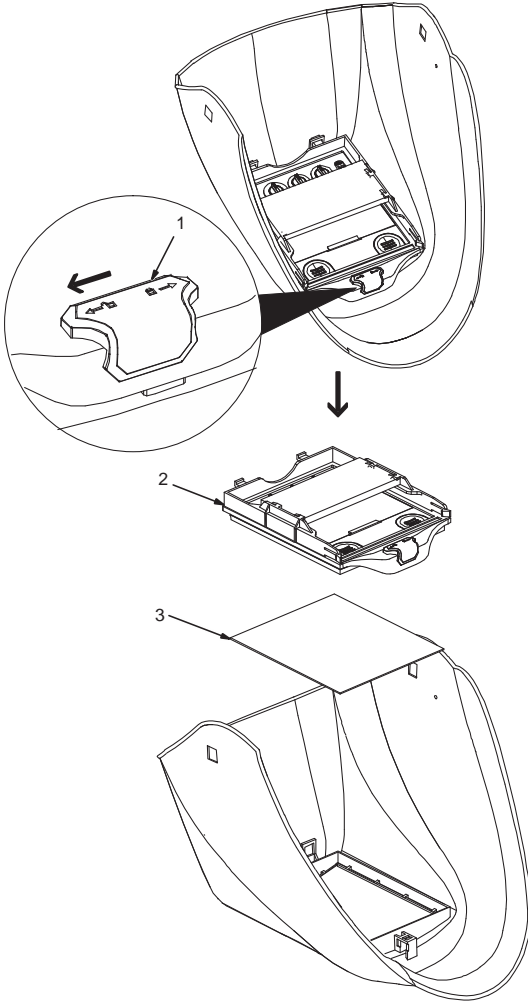

## 6-2. Replacing Inside Lens Cover

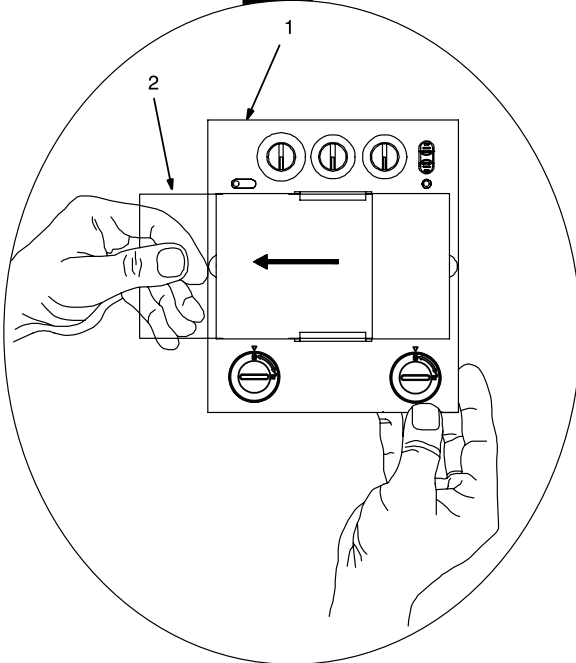
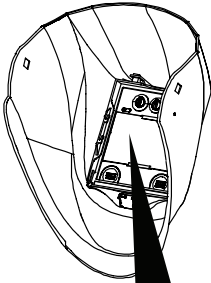

**⚠** Never use the auto-darkening lens without the inside and outside lens covers properly installed. Welding spatter will damage the auto-darkening lens and void the warranty.

- 1 Lens Assembly
- 2 Inside Lens Cover







Remove the lens cover holder (see Section 6-1). Remove lens assembly.

Remove the inside lens cover by prying the cover up at either thumbnail opening at each side of the cover. Slide cover it out of either side of frame. Replace lens cover and reinstall the assembly in the helmet by reversing the above procedure.

*☞ Be sure the cover lens is seated properly (flat) to prevent fogging.*

# SECTION 7 – REPLACING THE BATTERY

## 7-1. Replacing The Battery

						
--	---	---	---	---	---	---

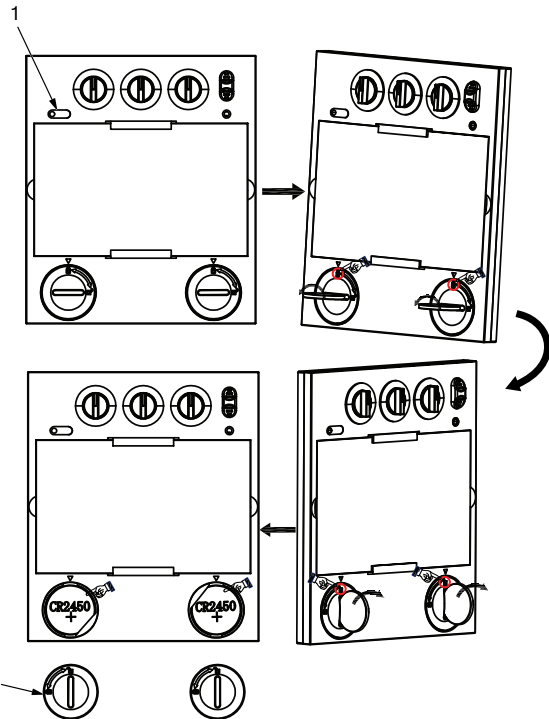

1

2

The helmet is powered by solar cells and two CR2450 lithium batteries.

**1 Low Battery Indicator**

The low battery indicator lights when 2-3 days of battery life remain.

If battery power is low, install two new CR2450 lithium batteries.

**2 Battery Cover**

Remove the lens cover holder (see Section 6-1). Remove lens assembly.

Unscrew battery cover using a coin or similar object. Remove the used batteries.

Install CR2450 Lithium batteries in correct polarity. Put the battery cover back into the lens assembly. Screw battery cover closed.

*Be sure Positive (+) side of the battery faces up (toward inside of helmet).*

Install lens assembly. Install the lens cover holder.

# SECTION 8 – INSTALLING OPTIONAL MAGNIFYING LENS

## 8-1. Installing Optional Magnifying Lens



### 1 Optional Magnifying Lens

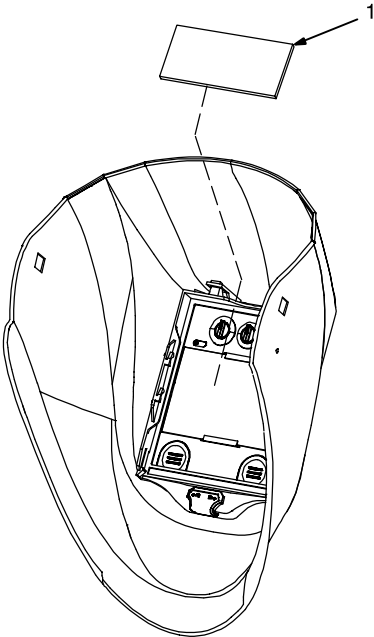

Slide magnifying lens into the helmet retaining brackets as shown. Align the magnifying lens with the auto-darkening lens assembly.

 *To prevent lens fogging, install flat side of magnifying lens toward auto-darkening lens.*



# SECTION 9 – MAINTENANCE AND TROUBLESHOOTING

## 9-1. Maintenance And Storage

-  *Do not use solvents or abrasive cleaning detergents to clean the helmet. Do not immerse the lens assembly in water.*
-  *Keep helmet dry; do not expose helmet to rain or snow. Keep helmet away from fire and other sources of heat.*
-  *The auto-darkening lens uses sensitive electronics. Do not drop helmet or handle it in a rough manner.*

The helmet requires little maintenance. However, for best performance clean helmet after each use. Using a soft cloth dampened with a mild soap and water solution, wipe the cover lenses clean. Allow to air dry. Occasionally, the filter lens and sensors should be cleaned by gently wiping with a soft, dry cloth.

Store helmet in a clean, dry, cool place free of solvent-based vapors. To prevent battery from losing power, store helmet in helmet bag or in a dark location. Remove battery(s) if helmet will be stored longer than six months.

### **End Of Useful Life**

The welding helmet has no expiration date, and with proper care and maintenance it can provide many years of eye and face protection. The helmet can continue to be used, provided that the helmet shell/shroud is undamaged (no cracks, gaps, or holes) and the lens functions normally (switches from a light state to a dark state.)

## 9-2. Troubleshooting



Trouble	Remedy
<p>Not switching – auto-lens stays light and does not darken when welding.</p>	<p>Stop welding immediately. If power is on, review the sensitivity recommendations and adjust sensitivity. Make sure helmet is not in Grind mode. Clean lens cover and sensors of any obstructions. Make sure the sensors are facing the arc; angles of 45° or more may not allow the arc light to reach the sensors.</p> <p>Check batteries and verify they are in good condition and installed properly. Also, check battery surfaces and contacts, and clean if necessary. Check batteries for proper contact and gently adjust contact points if necessary. This is particularly important if the helmet has been dropped.</p>
<p>Not Switching – auto-lens stays dark after the arc is extinguished, or the auto-lens stays dark when no arc is present.</p>	<p>Fine-tune the sensitivity setting by making small adjustments to the control by turning it toward the LO setting. In extreme light conditions, it may be necessary to reduce the surrounding light levels.</p>
<p>Sections of the auto-lens are not going dark, distinct lines separate the light and dark areas.</p>	<p>Stop welding immediately: The auto-lens may be cracked which can be caused by the impact of dropping the helmet. Weld spatter on the auto lens may also cause cracking. (The lens may need to be replaced; most cracked lenses are not covered by warranty).</p>
<p>Switching or Flickering – the auto-lens darkens then lightens while the welding or cutting arc is present.</p>	<p>Review the sensitivity setting recommendations and increase the sensitivity if possible. Be sure the arc sensors are not being blocked from direct access to the arc light.</p> <p>Check the lens cover for dirt and spatter that may be blocking the arc sensors. Increasing Lens Delay slightly may also reduce switching.</p>
<p>Inconsistent or lighter auto-lens shading in the dark-state, noticeable on the outside edges and corners.</p>	<p>Referred to as an angle of view effect, auto-darkening lenses have an optimum viewing angle.</p> <p>The optimum viewing angle is perpendicular or 90° to the surface of the auto-lens. When that angle of view varies in the dark-state, welders may notice slightly lighter areas at the outside edges and the corners of the lens. This is normal and does not represent any health or safety hazard.</p> <p>This effect may also be more noticeable in applications where magnifying lenses are used.</p>

# SECTION 10 – PARTS LIST

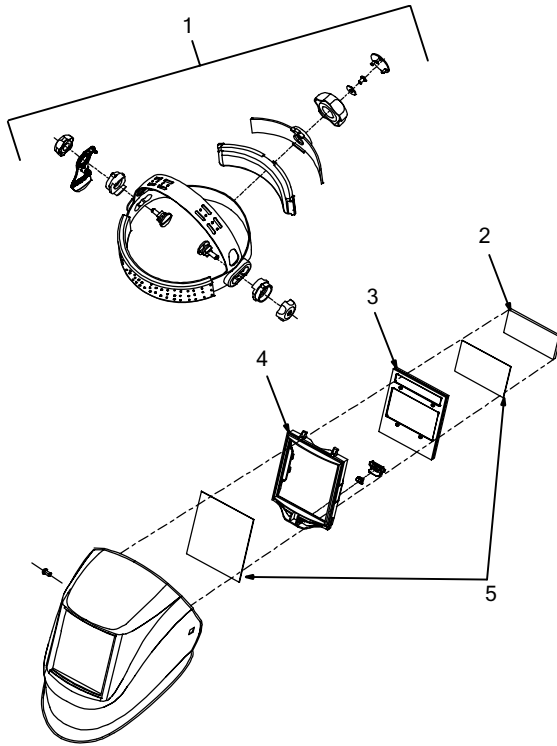

**Figure 10-1. Inventor Series Auto-Darkening Welding Helmet**

**10-1. Inventor Series Auto-Darkening Welding Helmet**

Item No.	Part No.	Description	Quantity
1	770843	Headgear	1
	216714	Label, Warning, Helmet EN/SP/FR	1
2	◆770274	Diopter Lens 150X	1
	◆770276	Diopter Lens 200X	1
	◆770277	Diopter Lens 250X	1
3	770846	Auto-Darkening Lens	1
		Battery, CR2450	2
4	770883	Frame, Lens Replacement	1
5	770858	Kit, Clear Protective Lens	1

◆Optional

# SECTION 11 – LIMITED WARRANTY

---

**LIMITED WARRANTY** – Subject to the terms and conditions below, Miller Electric Mfg. LLC, dba Hobart Welding Products, Appleton, WI, warrants to its original retail purchaser that the new Hobart equipment sold after the effective date of this limited warranty is free of defects in material and workmanship at the time it is purchased at the retailer. THIS WARRANTY IS EXPRESSLY IN LIEU OF ALL OTHER WARRANTIES, EXPRESS OR IMPLIED, INCLUDING THE WARRANTIES OF MERCHANTABILITY AND FITNESS.

Hobart auto-darkening lens helmets are warranted for two (2) years from the date of purchase. Proof of purchase is required for warranty transactions so it is imperative that a copy of the original invoice or sales receipt be retained.

This warranty provides specific legal rights, and other rights may be available depending on your state or province.

**For warranty transactions, contact your original Hobart retailer or call 1-800-332-3281.**

Effective January 1, 2024

Find us on 



[www.HobartWelders.com](http://www.HobartWelders.com)