



# PRODUCT SPECIFICATION

Ver:	A02
DATE:	2025-09-18
DOC No:	G07629-IFR26650

For any detail and question, please Email to [xgqiang@greatpower.net](mailto:xgqiang@greatpower.net)

Guangzhou Great Power Energy & Technology CO., Ltd  
广州鹏辉能源科技股份有限公司

Add:No. 912 Shiliang Rd(Xicun Section), Shawan, Panyu, Guangzhou, China  
地址:中国广州市番禺区沙湾镇市良路西村段 912 号

CUSTOMER NO: G07629

CUSTOMER'S PART NO: 1200400449

## Specification Approval Sheet 规格确认书

Product Model/成品型号: IFR26650

Product Rating/成品参数: 3.2V 3400mAh 10.88Wh

Cell Model/电芯型号: IFR26650

Cell Rating/电芯参数: 3.2V 3400mAh

Prepared By/Date 编制/日期	Checked By/Date 审核/日期	Approved By/Date 批准/日期

Customer Approval 客户确认	Signature/签字	Date/日期
	Company Name/公司名称	
	Company Stamp/公司印章	



For any detail and question, please Email to [xgqiang@greatpower.net](mailto:xgqiang@greatpower.net)

## Content/目录

1. Scope/适用范围	Page 4
2. Model/型号	Page 4
3. Battery specification/电池规格说明	Page 4/5
4. Battery performance test criteria/电池性能标准	Page 6
4.1 Appearance inspection by visual/外观目测	Page 6
4.2 Environmental test condition/外界环境条件	Page 6
4.3 Electrical characteristic/电气特性	Page 6
4.4 Mechanical characteristic/机械特性	Page 7/8
4.5 Safety performance/安全性能	Page 9
5. Cell initial Dimensions/电芯初始尺寸	Page 10
6. Battery specifications/产品规格	Page 11
7. Battery Pack Dimensions/电池组尺寸	Page 12
附页.Protection board specifications/保护板规格	Page 13/14
8. Cautions in use/谨慎使用	Page 15
9. Period of warranty/保质期	Page 15
10. Storage of the battery/电池的存放	Page 15
11. Other the chemical reaction/其它化学反应	Page 15
12. Environmental requirement/环保要求	Page 15
13. The remark of production duty/产品责任书	Page 15/16
14. Note/注释	Page 16

For any detail and question, please Email to [xgqiang@greatpower.net](mailto:xgqiang@greatpower.net)

## 1 Scope/适用范围

This specification is applies to describe the related Battery product in this Specification and the Battery/cell supplied by Guangzhou Great Power Energy & Technology CO., Ltd only.

本说明书只适用于描述本规格书中相关的产品以及广州鹏辉能源科技股份有限公司提供的电池。

## 2 Model/型号: IFR26650

## 3 Cell Specification/电芯产品规格

No.	Item/项目	Specification/规格		Remark/备注
1	Capacity 容量	Typical 典型	3400mAh	0.2C CC-CV to 3.65V, 0.01C cut off 0.2C DC to 2.0V ※1C=3.4A
		Minimal 最小	3300mAh	
2	Nominal voltage 标称电压	3.2V		
3	Delivery voltage 交货电压	30%-60%SOC, 25±5°C		Within 10 days from Factory 在出厂 10 天内
4	Limited charging voltage 充电限制电压	3.65V		
5	Upper limited charging voltage 充电上限电压	3.70V		
6	Standard charging method 标准充电方式	0.2C CC-CV to 3.65V, 0.01C cut off		0.2C 恒流充电至 3.65V, 再 3.65V 恒压充至电流至 0.01C
7	End of discharge voltage 放电终止电压	2.0V		
8	Discharge cut-off voltage 放电截止电压	2.0V		
9	Standard discharging method 标准放电方式	0.2C DC to 2.0V		0.2C 恒流放电至 2.0V
10	ACIR of cell 交流内阻	≤20mΩ		Internal resistance measured at AC 1KHz at 50%SOC 50%SOC 电态下用交流法测量内阻

For any detail and question, please Email to [xgqiang@greatpower.net](mailto:xgqiang@greatpower.net)

### 3 Cell Specification/产品规格(continuous/续上表)

No.	Item/项目	Specification/规格			Remark/备注
11	Recommendation charging current 推荐充电电流	0.2C	0.68A		By standard charge method 标准充电方式
12	Maximum charging current 最大充电电流	1C	3.4A		
13	Recommendation discharging current 推荐放电电流	0.2C	0.68A		By standard discharge method 标准放电方式
14	Maximum discharging current 最大放电电流	3C	10.2A		
15	Environment temperature & Charge-discharge limits 环境温度与充放电限制	项目 Items	温度 Temperature	最大电流 Maximum current	Low temperature charging and discharging efficiency will decrease, the temperature is too high or too low use will affect the cell life, it is prohibited to charge below 0°C. 低温充放电效率会下降, 温度过高或过低使用会影响电池寿命, 严禁 0°C 以下充电。
		Charge/充电	0≤T<15°C	≤0.5C	
			15≤T≤45°C	≤1C	
		Discharge/放电	-20≤T<0°C	≤1C	
0≤T≤60°C	≤3C				
16	Battery surface temperature & Charge-discharge limits 电池表面温度与充放电限制	Charge/充电	≤60°C		
		Discharge/放电	≤70°C		
17	Storage temperature and time 储存温度与时间 (Humidity 湿度 60±25% RH)	-20≤T≤25°C	≤12 个月		Suitable for long time storage 适合长时间存储
		-20≤T≤45°C	≤3 个月		cell's performance will be influenced after high temperature storage, please communicate with GP engineer to make sure all the details. 长期高温存储会影响产品的性能, 具体需与 GP 工程师进一步沟通确认。
		-20≤T≤60°C	≤1 个月		

For any detail and question, please Email to [xgqiang@greatpower.net](mailto:xgqiang@greatpower.net)

#### 4 Battery/Cell performance test Criteria/电池性能标准

##### 4.1 Appearance inspection by visual/外观目测

There shall be no such defect as rust, leakage, which may adversely affect commercial value of battery.  
 电池外观应没有锈渍、污渍、漏液等影响商业价值的缺陷存在。

##### 4.2 Environmental test condition/外界环境条件

Unless otherwise specified, all test stated in this product specification are conduct at below test condition.  
 所有测试应按以下环境条件进行，除非特殊指定外。

Temperature 温度:  $25 \pm 5^{\circ}\text{C}$

Relative humidity 相对湿度:  $60 \pm 25\% \text{ RH}$

Atmosphere pressure 大气压力:  $86 \sim 106 \text{ KPa}$

Test battery selection: Fresh batteries within one month after shipment from the factory and the batteries shall not be cycled more than five times before the test.

测试电池选择: 新电池不超过出厂时间 1 个月且循环次数低于 5 次。

##### 4.3 Cell Electrical characteristics/电气特性

No.	Item/项目	Test method and condition/测试方法及条件	Criteria/标准
1	Rate discharge 倍率放电	After standard charge, the capacity shall be measured on rate discharge till the voltage discharge to 2.0V. 标准充电后，放电至 2.0V 截止，测量不同电流放电容量。	0.2C $\geq 3.30\text{Ah}$
			1C $\geq 3.20\text{Ah}$
			3C $\geq 3.05\text{Ah}$
2	Cycle life 循环寿命	Charging and discharging battery as blew conditions: A. 0.2C CC-CV to 3.65V, 0.05C cut off B. T=10min C. 0.2C DC to 2.0V D. T=30min  Continue to perform 2000 cycles at work step A-D, the capacity will be measure after the 2000 <sup>th</sup> cycle. 充放电按以下条件: 0.2C 恒流充电至 3.65V, 再恒压充电至 0.05C 截止, 静置 10 分钟, 0.2C 放电至 2.0V, 静置 30 分钟。连续充放电循环 2000 周, 在第 2000 周结束后测量容量。	$\geq 80\% @ \text{初始容量}$
3	Storage performance at room temperature 室温存储性能	The cell is to be charge in accordance with standard charge condition at $20 \sim 25^{\circ}\text{C}$ , then storage the cell at an ambient temperature $20 \sim 25^{\circ}\text{C}$ for 28 days. Measure the capacity after 28 days with 0.2C at $20 \sim 25^{\circ}\text{C}$ as retention capacity. Then charge and discharge with 0.2C at $20 \sim 25^{\circ}\text{C}$ as recover capacity. 将电池在 $20 \sim 25^{\circ}\text{C}$ 标准充电后储存在 $20 \sim 25^{\circ}\text{C}$ 的环境中 28 天。28 天后, 测试电池在 $20 \sim 25^{\circ}\text{C}$ 环境下 0.2C 放电容量作为保持容量。然后在 $20 \sim 25^{\circ}\text{C}$ 环境下测试 0.2C 充放电容量作为恢复容量。	Retention capacity 容量保持 $\geq 85\%$ Recover capacity 容量恢复 $\geq 90\%$
4	Storage performance at high temperature 高温存储性能	The cell is to be charge in accordance with standard charge condition at $20 \sim 25^{\circ}\text{C}$ , then storage the cell at an ambient temperature $60 \pm 2^{\circ}\text{C}$ for 7 days. Measure the capacity after 7 days with 0.2C at $20 \sim 25^{\circ}\text{C}$ as retention capacity. Then charge and discharge with 0.2C at $20 \sim 25^{\circ}\text{C}$ as recover capacity. 将电池在 $20 \sim 25^{\circ}\text{C}$ 标准充电后储存在 $60 \pm 2^{\circ}\text{C}$ 的环境中 7 天。7 天后, 测试电池在 $20 \sim 25^{\circ}\text{C}$ 环境下 0.2C 放电容量作为保持容量。然后在 $20 \sim 25^{\circ}\text{C}$ 环境下测试 0.2C 充放电容量作为恢复容量。	Retention capacity 容量保持 $\geq 80\%$ Recover capacity 容量恢复 $\geq 85\%$

For any detail and question, please Email to [xgqiang@greatpower.net](mailto:xgqiang@greatpower.net)

No.	Item/项目	Test method and condition/测试方法及条件	Criteria/标准
5	Temperature dependence of discharge capacity 放电温度特性	Cells shall be charged per 3.6 and discharged @0.2C to 2.0V. Except to be discharged at temperatures per Table 1. Cells shall be stored for 4h (low temperature) or 2h (high temperature) at the test temperature prior to discharging and then shall be discharged at the test temperature. The capacity of one cell at each temperature shall be compared to the capacity achieved at 25°C and the percentage shall be calculated. 电池按 3.6 规定充电。按表 1 的温度中放电，电池必须先在该试验温度中放置，低温 4h/高温 2h。	Each cell shall meet or exceed the requirements of Table 1 不同温度放电容量应不小于表 1 的要求

Table 1 (表 1)

Discharge temperature/放电温度	-20°C	-10°C	0°C	25°C	60°C
0.2C Discharge capacity/0.2C 放电容量	>40%	>60%	>80%	100%	>95%

#### 4.4 Mechanical characteristics/机械特性(参考 GB 31241-2014)

No.	Item/项目	Test method and condition/测试方法及条件	Criteria/标准
1	Low pressure 低气压	After standard charge, to be stored for 6 hours at an absolute pressure of 11.6kPa and a temperature of 25±5°C. 电芯标准充满电后，放置在 25°C ±5°C 的真空箱中，箱内压强降至 11.6kPa，并保持 6h。	No explosion, No fire 无爆炸，无起火
2	Temperature cycle 温度循环	After standard charge, the cells are to be placed in a test chamber and subjected to the following cycles: a) Raising the chamber-temperature to 75±3°C within 30min and maintaining this temperature for 6h. b) Reducing the chamber temperature to -40±3°C within 30min and maintaining this temperature for 6h. c) Repeating the sequence for a further 10 cycles. d) After the 10th cycle, storing the cell for a minimum of 24h, at a temperature of 25±5°C prior to examination. 电芯标准充满电后，放置在可控温箱体中，进行如下步骤： 1、在 75±3°C 温度下保持 6h； 2、在 -40±3°C 温度下保持 6h，温度间转换时间 ≤30min； 3、再次将温度升为 75±3°C，温度转换时间 ≤30min； 4、重复 2~3 步骤，共循环 10 次； 5、取出在 25±5°C 下静置 24h，观察。	No leakage, No explosion, No fire 无泄漏，无爆炸，无起火

For any detail and question, please Email to [xgqiang@greatpower.net](mailto:xgqiang@greatpower.net)

#### 4.4 Mechanical characteristics/机械特性(参考 GB 31241-2014)

No.	Item/项目	Test method and condition/测试方法及条件	Criteria/标准
3	Free fall test 自由跌落测试	The cell is to be fully charged in accordance with standard charge condition, then drop the cell three times from a height of 1.0m onto a concrete floor. One fall on each end surface and two falls on the cylinder, A total of four falls. 电池按照标准充电条件充满电, 然后从1.0m高度跌落电池到一个水泥地面, 端面各跌落一次, 圆柱面跌落2次, 共跌落4次。	No leakage, No explosion, No fire 无泄漏, 无爆炸, 无起火
4	Vibration test 振动测试	After standard charging, fixed the cell to vibration table and subjected to vibration cycling that the frequency is to be varied at the rate of 1Hz per minute between 10Hz and 55Hz, the excursion of the vibration is 1.6mm. The cell shall be vibrated for 30 minutes per axis of X, Y, Z axes. 将标准充电后的电芯固定在振动台上, 沿 X、Y、Z 三个方向各振动 30 分钟, 振幅 1.6mm, 振动频率为 10Hz~55Hz, 每分钟变化 1Hz。	No leakage, No explosion, No fire 无泄漏, 无爆炸, 无起火
5	Shock test 加速度冲击	The cell is to be secured to the testing machine by means of a rigid mount which supports all mounting surfaces of the cell. Each cell shall be subjected to a total of three shocks of equal magnitude. The shocks are to be applied in each of three mutually perpendicular directions unless it has only two axes of symmetry in which case only two directions shall be tested. Each shock is to be applied in a direction normal to the face of the cell. For each shock the cell is to be accelerated in such a manner that during the initial 3ms the minimum average acceleration is 75gn (where g is the local acceleration due to gravity). The peak acceleration shall be between 150±25gn. 电池按照标准充电条件充满电, 固定在冲击台上, 进行半正弦脉冲冲击实验, 在最初的 3ms 内, 最小平均加速度为 75gn, 峰值加速度为 150±25gn, 脉冲持续时间为 6±1ms。电池每个方向 进行三次加速度冲击试验。圆柱型和纽扣型电池按照其轴向和径向两个方向进行冲击试验, 方型和软包装电池按照 3 个相互垂直的方向依次进行冲击试验。	No leakage, No explosion, No fire 无泄漏, 无爆炸, 无起火
6	Crush test 挤压测试	After standard charged, the cell is to be placed between two flat plates. The plate is pressed at a rate of (5±1)mm/s, until the extrusion force reaches 13.0±0.78kN. 电池在标准满充后, 放置在两块挤压板间。极板以(5±1)mm/s 的速度垂直于电池极板方向施压, 直到挤压力达到 13.0±0.78kN 即可停止挤压。	No explosion, No fire 无爆炸, 无起火
7	Thermal exposure test 热冲击测试	Each fully charged cell, stabilized at room temperature, is placed in a circulating air-convection oven. The oven temperature is raised at a rate of 5±2°C/min to a temperature of 130±2°C. The cell remains at this temperature for 30 minutes before the test is discontinued. 充满电的电池温度稳定到常温后, 放置入循环空气烘箱里, 从常温以5±2 °C/分的速率升至130±2°C后, 在130± 2°C放置30分钟。	No explosion, No fire 无爆炸, 无起火

For any detail and question, please Email to [xgqiang@greatpower.net](mailto:xgqiang@greatpower.net)

#### 4.5 Safety performance/安全性能(参考 GB 31241-2014)

No.	Item/项目	Test method and condition/测试方法及条件	Criteria/标准
1	Short test 短路测试(25±5℃)	<p>The fully charged cell is to be short-circuited by connecting the positive and negative terminals of the cell with resistance load <math>80 \pm 20\text{m}\Omega</math>. Tests are to be conducted at room temperature about <math>25 \pm 5^\circ\text{C}</math>. When the cell catches fire, explodes, leaks or completely discharges to the voltage less than 0.1v and temperature of the cell drops to the ambient temperature of <math>\pm 10^\circ\text{C}</math>, the test will be completed.</p> <p>在室温约为 <math>25 \pm 5^\circ\text{C}</math> 把充满电的电池的正负极用全部外接电阻 <math>80 \pm 20\text{m}\Omega</math> 的负载连接起来, 连接起来使电池外部短路。当电池发生起火、爆炸、漏液或电池完全放电至电压小于 0.1V 并且电池温度下降到环境温度 <math>\pm 10^\circ\text{C}</math> 时, 结束试验。</p>	<p>No explosion, No fire The temperature of the cell surface not exceeded than <math>150^\circ\text{C}</math> 无爆炸, 无起火, 电池表面温度不超过 <math>150^\circ\text{C}</math></p>
2	Short test 短路测试(55±5℃)	<p>Tests are to be conducted at temperature about <math>55 \pm 5^\circ\text{C}</math> and remain the cell 30 minutes. The fully charged cell is to be short-circuited by connecting the positive and negative terminals of the cell with resistance load <math>80 \pm 20\text{m}\Omega</math>. When the cell catches fire, explodes, leaks or completely discharges to the voltage less than 0.1v and temperature of the cell drops to the ambient temperature of <math>\pm 10^\circ\text{C}</math>, the test will be completed.</p> <p>在约为 <math>55 \pm 5^\circ\text{C}</math> 环境下静置 30 分钟后, 把充满电的电池的正负极用全部外接电阻 <math>80 \pm 20\text{m}\Omega</math> 的负载连接起来, 连接起来使电池外部短路。当电池发生起火、爆炸、漏液或电池完全放电至电压小于 0.1V 并且电池温度下降到环境温度 <math>\pm 10^\circ\text{C}</math> 时, 结束试验。</p>	<p>No explosion, No fire The temperature of the cell surface not exceeded than <math>150^\circ\text{C}</math> 无爆炸, 无起火, 电池表面温度不超过 <math>150^\circ\text{C}</math></p>
3	Forced discharge test 强制放电测试	<p>A discharged cell is subjected to a reverse charge at 1C for 90 minutes. 将电池放完电, 再用1C反接充电90分钟。</p>	<p>No explosion, No fire 无爆炸, 无起火</p>
4	Over charge test 过充电测试	<p>After standard discharge, continue to charge with a constant voltage 3C/5.0V per a cell, holding 12h. 电池标准放电后, 以 3C/5.0V 的恒定电压继续充电, 保持 12 小时。</p>	<p>No explosion, No fire 无爆炸, 无起火</p>

For any detail and question, please Email to [xgqiang@greatpower.net](mailto:xgqiang@greatpower.net)

### 5 Cell initial dimension / 电池初始尺寸(含 PVC)

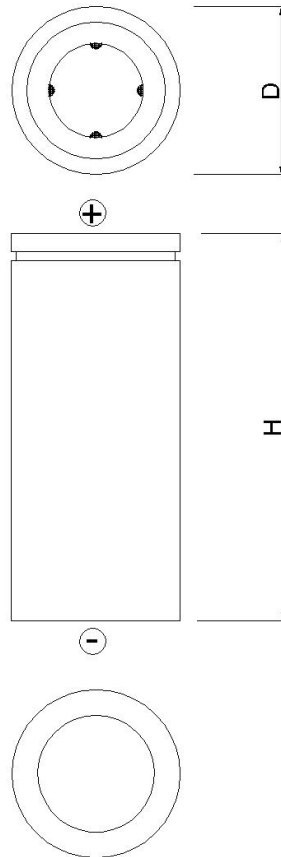

NO.	Item/项目	Flat cap/平帽	Remark/备注
1	Diameter/直径(D)	$26.4 \pm 0.2\text{mm}$	盖帽内含 CID、防爆阀片等保护装置 The cap contains CID, Vent protection devices
2	Height/高度(H)	$65.0 \pm 0.3\text{mm}$	

For any detail and question, please Email to [xgqiang@greatpower.net](mailto:xgqiang@greatpower.net)

## 6 Battery specifications/产品规格

No.	Items/项目	Specifications/规格		Remark 备注
1	Capacity for assembled cell discharging by 0.2C 电芯组装后 0.2C 标准放电的容量	Typical 典型	3400mAh	Standard discharging method 标准放电方式
		Minimal 最小	3300mAh	
2	Battery Voltage 电池电压	≥3.2V		Delivery Voltage, Within 10 days from Factory 交货电压, 在出厂 10 天内
3	Standard charge condition 标准充电条件	Charge with 0.2C constant current and 3.65V constant voltage, charge to 3.65V, continue charging till current decline to ≤0.01C 充电电流用 0.2C 恒流, 3.65V 恒压充至电流 ≤0.01C		Charge voltage: 3.65V±0.05V Charge current: 0.2C 充电电压: 3.65V±0.05V 充电电流: 0.2C
4	Standard discharging method 标准放电方式	0.2C constant current discharge to 2.0V		0.2C 恒流放电至 2.0V
5	Internal Impedance 内阻	Assemblage Impedance 装配后内阻 ≤120mΩ		Measure the Red and black wire of the connector after assembling. 装配后测试电池插头红黑线
6	Weight 重量	93.067g ~ 93.985g		

For any detail and question, please Email to [xgqiang@greatpower.net](mailto:xgqiang@greatpower.net)

7 Battery Pack Dimensions/电池组尺寸

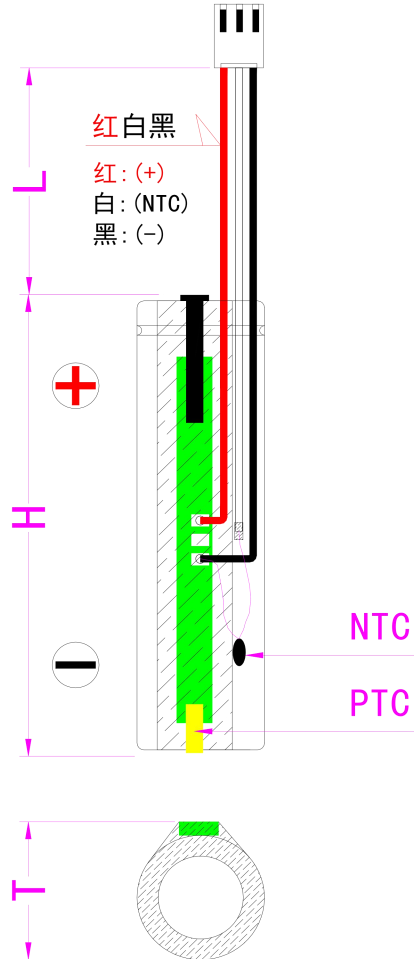

喷码内容:

GREAT POWER  
IFR26650 3400mAh 3.2V 10.88Wh  
2024-11-06 (按实际出货日期)

NO	Items	Units: mm		Remark
1	Thickness/厚度	T	31.0	Max
2	Height/高度	H	67.5	Max
3	Cable Length/引线长度	L	100.0±5.0	

NO	Part name/名称	Quantity/数量	Unit/单位	Remark
1	Cell/电芯	1	Ea	Great Power
2	Solder/焊锡	0.04	G	Lead Free
3	PCM/保护板	1	Ea	P-1SPM53AX-N
4	Counter/插头	1	Ea	JST-VH-3P 正向
5	Wire/导线	3	Ea	UL1007#20AWG 红白黑-线序
6	NTC	1	Ea	滴水状 100K: MF52B 104F410030Z0120
7	PTC	1	Ea	JK-M550

For any detail and question, please Email to [xgqiang@greatpower.net](mailto:xgqiang@greatpower.net)

附页：保护板参数

1. 技术规格 specification

1.1 适用范围 using scope: 本规格书适用于由本公司所设计生产的 P-1SPM53AX-N 锂电保护板

1.2 电池容量 battery capacity: (客户选择)

1.3 环保要求 environment request: ROHS

1.4 功能描述 function description: 过充保护, 过放保护, 过流保护, 短路保护

1.5 技术参数 electric features:

环境温度: 25 °C

保护 IC	项目名称 Item name	技术参数 parameter value			单位 unit
		最小值 min	典型值 type	最大值 max	
	过充保护电压 Over-charge Threshold Voltage	3.625	3.650	3.675	V
	过充保护恢复电压 Released voltage from Over-charge	3.400	3.450	3.500	V
	充电过流检测电压 Charging overcurrent detection voltage	-0.300	-0.250	-0.200	V
	充电过流保护电流 Charging discharge-current detect current	-12.5	-8.5	-4.5	A
	过放保护电压 Over-discharge Threshold	2.450	2.500	2.550	V
	过放保护恢复电压 Released Voltage from Over-discharge	2.950	3.000	3.050	V
	放电过流检测电压 Excess discharge-current threshold	0.185	0.200	0.215	V
	放电过流保护电流 excess discharge-current detect current	4.5	7.0	9.5	A
	过充电检测延迟时间 Output Delay of Over-charge	0.7	1.0	1.3	S
	过放电检测延迟时间 Output Delay of Over-discharge	115	145	175	ms
	过电流检测延迟时间 Output delay of excess discharge-current	9	12	15	ms
	短路保护延迟时间 Delay Time for Short Protection	200	300	400	μs
	正常状态下静态电流 Supply Current	1.0	4.0	8.0	μA
	过放状态下静态电流 Standby Current	0.01	-	0.1	μA
	导通内阻 Impedance Resistance of operation	-	-	90	mΩ
	输入电压 (B+与 B-间) Supply Voltage	1.5	-	8.0	V
	最大持续充电电流 Max charge-current	-	-	-3.0	A
	最大持续放电电流 Max discharge-current	-	-	4.0	A
	工作温度 Operating Temperature	-20	-	+85	°C
	推荐贮存条件 Storage Temperature	-40	-	+125	°C
	0V 电池充电功能 for 0V Charging	-	允许	-	

1.6 可靠性测试

- 恒温恒湿测试 Humidity test : +40±2 °C 90%RH 48Hours 高温测试 High temperature test : +55±2 °C 2Hours
- 低温测试 Low temperature test : -20±2 °C 16Hours
- ESD 抗静电测试 ESD test : Normal operation in all parts at ±4KV (contact) ±8KV (AIR) condition

For any detail and question, please Email to [xqjiang@greatpower.net](mailto:xqjiang@greatpower.net)

附页：保护板参数

2. 电气原理 Circuit diagram

2.1 电气原理图 circuit diagram

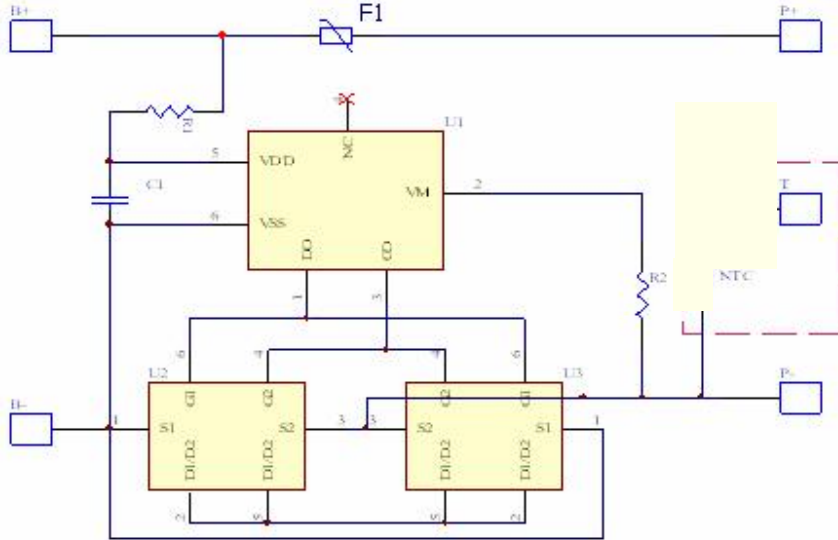

2.2 PCB 图 PCB layout

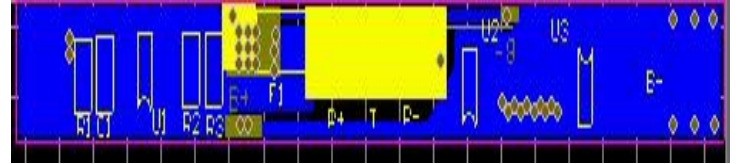

2.3 NTC 电阻温度曲线图

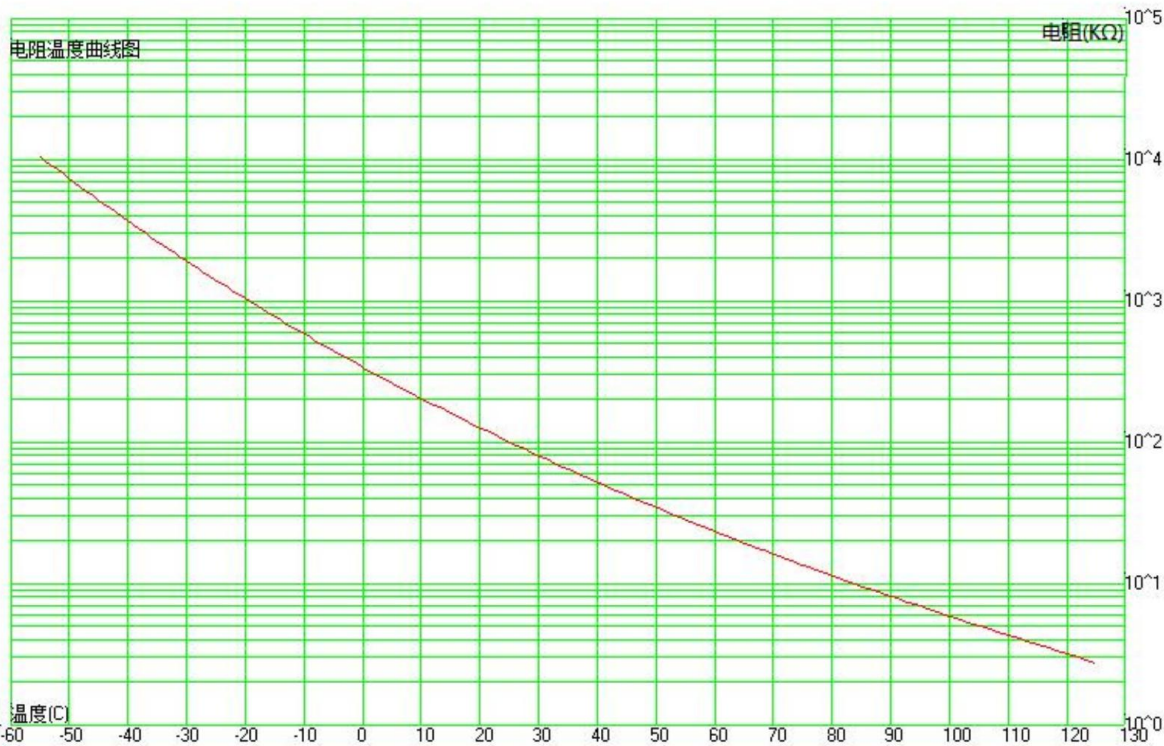

For any detail and question, please Email to [xgqiang@greatpower.net](mailto:xgqiang@greatpower.net)

附页：保护板参数

### 3. 物料清单 parts list

序号 No.	物料名称 description	供应商 vendor	代号 symbol	规格/型号 Spec./model	单位 unit	数量 Q' ry
1	PCB 板	鹏豪		PT1-1S1PM53-T(53*5*0.4mm)	pcs	1
2	电阻		R1	100/0603	pcs	1
3	电阻		R2	2K/0603	pcs	1
4	电容		C1	104/0603	pcs	1
5	IC		U1	HY2112-HB SOT23-6 / SOT23-6	pcs	1
6	MOS		U2U3	HD8205/SOT23-6(代替 DP8205)	pcs	2
7	镍片		F1	2*3*0.3mm	pcs	1
8	镍片		B-B+	3*15*0.2mm	pcs	2

### 8 Cautions in use(谨慎使用)

- To ensure proper use of the battery please read the manual carefully before using it. (为确保正确使用电池，使用前请仔细阅读本细则)
- Handling (电池操作) :
  - Do not expose to, dispose of the battery in fire. (不要靠近和放置电池于火中)
  - Do not put the battery in a charger or equipment with wrong terminals connected. (在充电器或设备仪器中不要把电池接错电极)
  - Avoid shorting the battery (避免电池短路)
  - Avoid excessive physical shock or vibration. (避免电池过多的物理撞击和震动)
  - Do not dismantle, open or shred the battery. (不要私自拆除、打开或分解电池)
  - Do not immerse in water. (不要把电池浸泡在水中)
  - Do not use the battery mixed with other different make, type, or model batteries. (不要和其它不同类型的电池混和使用)
  - Keep out of the reach of children. If swallowed, see a doctor immediately. (电池放置于儿童不易接触的地方。如发现吞食，立即联系医生)
- Charge and discharge (充电和放电) :
  - Battery must be charged in appropriate charger only. (电池必须用合适的充电器充电)
  - Do not maintain the battery on charge when not in use. (当电池不使用时，不要把电池一直放置于充电器中)
- Storage (储存) : Store the battery in a cool, dry and well-ventilated area. (应把电池置于凉爽、干燥及通风良好的区域)
- Disposal (电池处理) : Dispose of in accordance with local regulations. (电池处理要符合当地的规定)

### 9 Period of warranty/保质期

The period of warranty is one year from the date of shipment. Great Power guarantees to give a replacement in case of batteries with defects proven due to manufacturing process instead of the customer abuse and misuse.

电池的保质期从出货之日算起为一年。如果证明电池的缺陷是在制造过程中形成的，而不是由于用户滥用及错误使用造成，本公司负责退换电池。

### 10 Storage of the batteries/电池的存储

The batteries should be stored at room temperature, charged to about 30% to 50% of capacity. If stored for a long period of time, we recommend that charged about once per half a year to prevent over discharge.

电池应当充电到 30%~50%电量后在室温下存放。如需要长时间储存，建议每半年充一次电以防止电池过放电。

For any detail and question, please Email to [xgqiang@greatpower.net](mailto:xgqiang@greatpower.net)

#### 11 Other chemical reaction/其它化学反应

Because batteries utilize a chemical reaction, battery performance will deteriorate over time even if stored for a long period of time without being used. In addition, if the various usage conditions such as charge, discharge, ambient temperature, etc. are not maintained within the specified ranges the life expectancy of the battery may be shortened or the device in which the battery is used may be damaged by electrolyte leakage. If the batteries cannot maintain a charge for long periods of time, even when they are charged and discharged correctly, this may indicate it is time to change the battery.

因为电池是利用化学反应实现其充放电功能，即使电池不使用，长期储存也会导致电池性能随着时间的推移而恶化。此外，如果充电、放电、环境温度等各种使用条件不在规定范围内，则可能缩短电池的寿命或导致电池漏液而损坏使用电池的设备。如果电池按正确方法充放电，长时间充不进电，这说明电池需要更换了。

#### 12 Environmental requirement/环保要求

This product complies with corporation class I controlled substance standard such as ROHS2.0, REACH and EU battery directives.

本产品符合公司 I 类管控物质标准:ROHS2.0、REACH 法规(EC NO.1907/2006)和欧盟电池指令(2006/66/EC)等。

#### 13 The remark of production duty/产品责任书

Customers are responsible to confirm and assure the matching and reliability of Li-ion batteries under actual application.

在实际应用中，客户有责任确认和保证电池与设备装置的匹配性和可靠性。

Customers must strictly operate according to this specification. Please fully evaluate the possible shortening of service life at higher than ambient temperature before use. The company will be an exemption from liability if the Li-ion battery is improperly used or abused and then cause a fire, explosion, the human body or property damage.

在使用电池之前，必须严格遵照本产品规格书进行操作。高于环境温度的使用可能会导致使用寿命的减少，使用前请充分评估。误用将会引起电池出现发热、爆炸，而造成人体伤害或财产损失。对于没有按照产品规格书进行操作而造成的任何意外事故，本公司将不承担任何责任。

#### 14 Note/注释

Any other items which are not covered in this specification shall be agreed by both parties.

本说明书未包括事项应由双方协议确定。

Single Cell Battery /单电芯电池 (IFR26650 3,2V 3400mAh 10,88Wh)

