

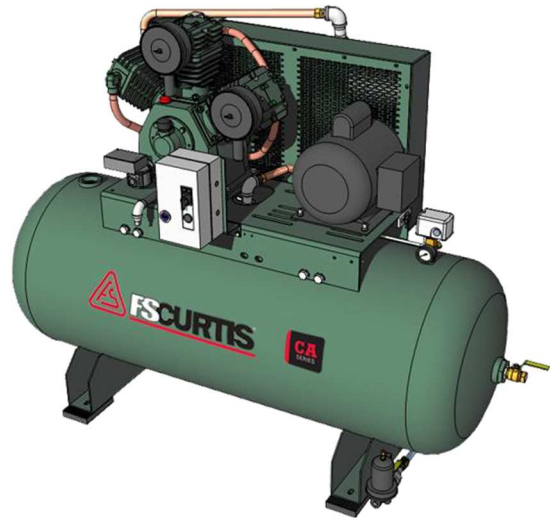

CA Series

TWO STAGE RECIPROCATING AIR COMPRESSORS

Installation and Operations Manual



WARNING

Personal injury and/or equipment damage will result by failing to pay attention to the vital safety information and instructions in this manual. Carefully read, understand, and retain all safety information and instructions before operating this compressor.

P/N

S/N

Please have your unit's part number P/N and serial number S/N ready when calling for service. This information can be found on the compressor nameplate.

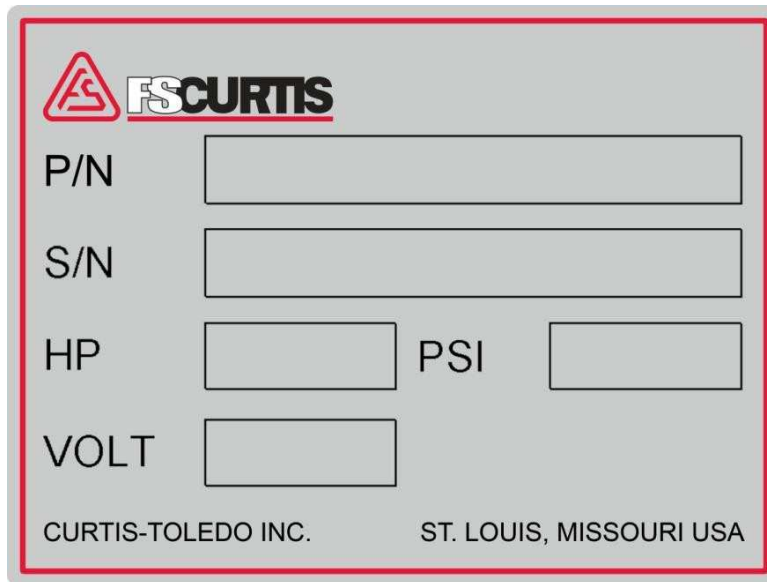

The image shows a rectangular nameplate form with a red border. At the top left is the FSCURTIS logo, which consists of a red triangle containing a white 'S' and the word 'FSCURTIS' in bold black letters. Below the logo are four rows of input fields: 'P/N' with a wide rectangular box, 'S/N' with a wide rectangular box, 'HP' with a small rectangular box followed by 'PSI' and another small rectangular box, and 'VOLT' with a small rectangular box. At the bottom of the form, the text 'CURTIS-TOLEDO INC.' is on the left and 'ST. LOUIS, MISSOURI USA' is on the right.

For Customer Service, Technical Service, or to order replacement parts, please contact your local distributor.

Visit our website at: www.fscurtis.com

Table of Contents

Read Me First	Section 1
Safety Precautions.....	3-4
System Diagram.....	5-6
Installation	Section 2
Receiving.....	7
Freight Damage.....	8
Installation Procedure.....	8-12
Post Installation Checklist.....	13
Electrical Requirements	14
Wiring Diagrams	Section 3
Simplex, 1 phase and 3 phase	15
Duplex, dual source.....	16
Start Up	Section 4
Pre-Start Checklist	17
Start-Up Procedure	18
Pilot Valve Adjustment.....	19-21
Maintenance	Section 5
Shut Down Procedure	22
Maintenance Schedule	23
Oil	24
Low Oil Guard.....	25
Bolt Torques.....	26
Belt Tension	27-29
Maintenance Parts List.....	29
Troubleshooting	Section 6
Troubleshooting Guide.....	30-31
Maintenance Checklists.....	32-33

SECTION 1: READ ME FIRST

SAFETY PRECAUTIONS

The owner, lessor or operator of any compressor unit manufactured by FS Curtis, Inc. is hereby warned that failure to observe all safety precautions may result in serious injury of personnel and/or damage to property.

FS Curtis, Inc. neither states as fact, nor in any way implies that this list of safety precautions is an all-inclusive list, the observance of which will prevent all damage to property or injury to personnel.

Every reasonable effort has been taken to ensure that complete and correct instructions have been included in this manual. However, possible updates and changes may have occurred since this printing. FS Curtis, Inc. reserves the right to change specifications, without incurring any obligation for equipment previously or subsequently sold.

Compressors and/or units are assembled to comply with the customer's purchase order and in compliance with FS Curtis, Inc. specifications; alteration must not be made to the compressor or unit without FS Curtis' written approval.

DANGER!

Air used for breathing or food processing must meet O.S.H.A 29 C.F.R. 1910.134 or F.D.A. 21 C.F.R. 178.350 regulations. Failure to do so will cause severe injury or death.

WARNING!

Compressors are precision high-speed mechanical equipment requiring caution in operation to minimize hazard to property and personnel. Listed below are some safety precautions that must be observed.

- Use of FS Curtis Compressors to transfer toxic, radioactive, flammable, or explosive substances is prohibited.
- Do not install the compressor in an area where there is a risk of exposure to explosive gases or combustible dusts, such as flours, starches, coke, coal dust, etc. or in close proximity to corrosive substances.
- Release all air pressure from the system before working on the unit and red tag all electrical control switches.
- Do not assume it is safe to operate on a compressor simply because it is not running, it could restart at any time. Turn off the power to the unit (open the disconnect) to ensure the compressor does not start.
- Do not operate compressor on a shipping skid or any other unapproved mounting surfaces.
- Do not by-pass motor over-current protection.

- Do not change the setting or in any way affect the operation of the safety valves.
- Turn off and lockout/tag out the main power disconnect switch before attempting to work or perform any maintenance.
- Do not attempt to service any part of this unit while it is running.
- Ensure that service personnel are properly trained before attempting to service any part of the electrical system.
- Do not operate the unit with any of its safety guards, shields or screens removed.
- Do not remove or paint over any DANGER! , WARNING! , CAUTION! , or instructional materials attached to the compressor. Lack of information regarding hazardous conditions can cause property damage or personal injury.
- Do not change the pressure setting of the pressure relief valve, restrict the function of the pressure relief valve, or replace the pressure relief valve with a plug.
- Do not install a shutoff valve in the compressor discharge line without first installing a pressure relief valve of proper size and design between the shutoff valve and the compressor.
- Do not use plastic pipe, unapproved rubber hose, or lead-tin soldered joints in any part of the compressed air system.
- Alterations must not be made to this compressor without FS Curtis' expressed, written approval.
- Do not operate the compressor in excess of the A.S.M.E. pressure vessel rating for the receiver or the service rating of the compressor, whichever is lower.
- Surface temperatures can exceed 400 °F, power off the unit and allow it to cool before touching any surface of the compressor.
- Provisions should be made to have the instruction manual readily available to the operator and maintenance personnel. If for any reason any part of the manual becomes illegible or the manual is lost, contact your local distributor.
- Your State and/or local OSHA regulations may require a Pressure Vessel Permit to operate this equipment. Obtaining a permit is the sole responsibility of the owner, lessor or operator of the equipment. Contact your State/Local OSHA for more information.
- This product can expose you to chemicals including LEAD, ETHYL ACRYLATE, FORMALDEHYDE, NAPHTHALENE, CUMENE, and ETHYLBENZENE which are known to the state of California to cause cancer and birth defects or other reproductive harm. For more information go to WWW.P65WARNINGS.CA.GOV

SYSTEM DIAGRAM

Simplex Units

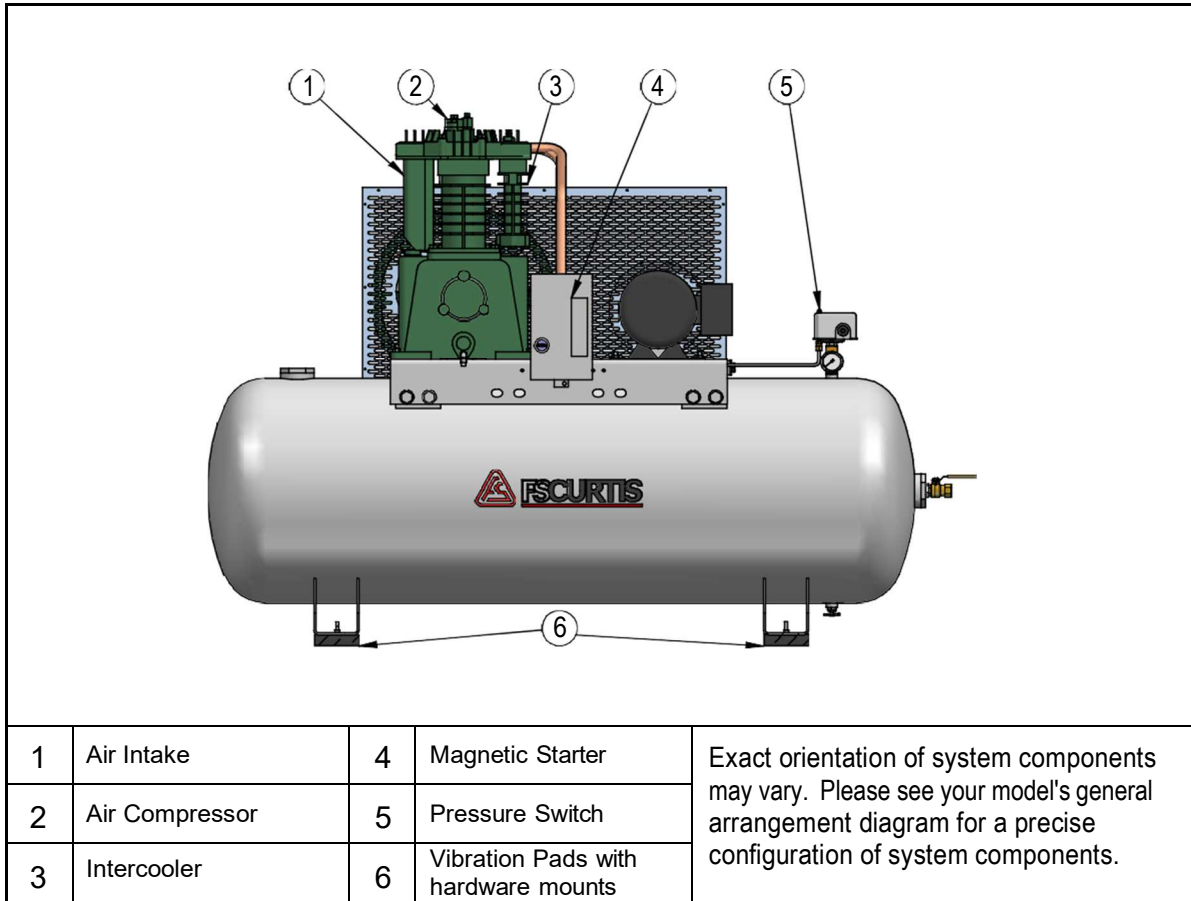

Fig. (1) Simplex, two stage air compressor process.

FS Curtis manufactures a broad array of compressor configurations to satisfy the needs of our diverse customer base. Despite this diversity, all FS Curtis two stage compressor configurations work off the same basic cycle. Air is drawn into the compressor through the air intake and filter assembly. The air enters the first stage, a low pressure chamber where it is compressed a first time. As air is compressed, its temperature increases, this hot air then enters the intercooler where the temperature is reduced. Next, the cooled air enters the second stage, a high pressure chamber where the air is compressed a second time to even higher pressures and discharged into the tank. An Ultra Pack option can be purchased with an installed air-cooled after-cooler which, after the second compression stage, cools the air to a 20°F approach temperature before being stored in the tank.

When the compressor has filled the tank to its pressure rating, the pressure switch disengages which turns off the motor, preventing the tank from over pressurizing. Finally, the tank has a ball valve which is opened or closed by the operator and lets air out of the tank, the ball valve is depicted in Fig (1) in the “open” position.

Duplex Units

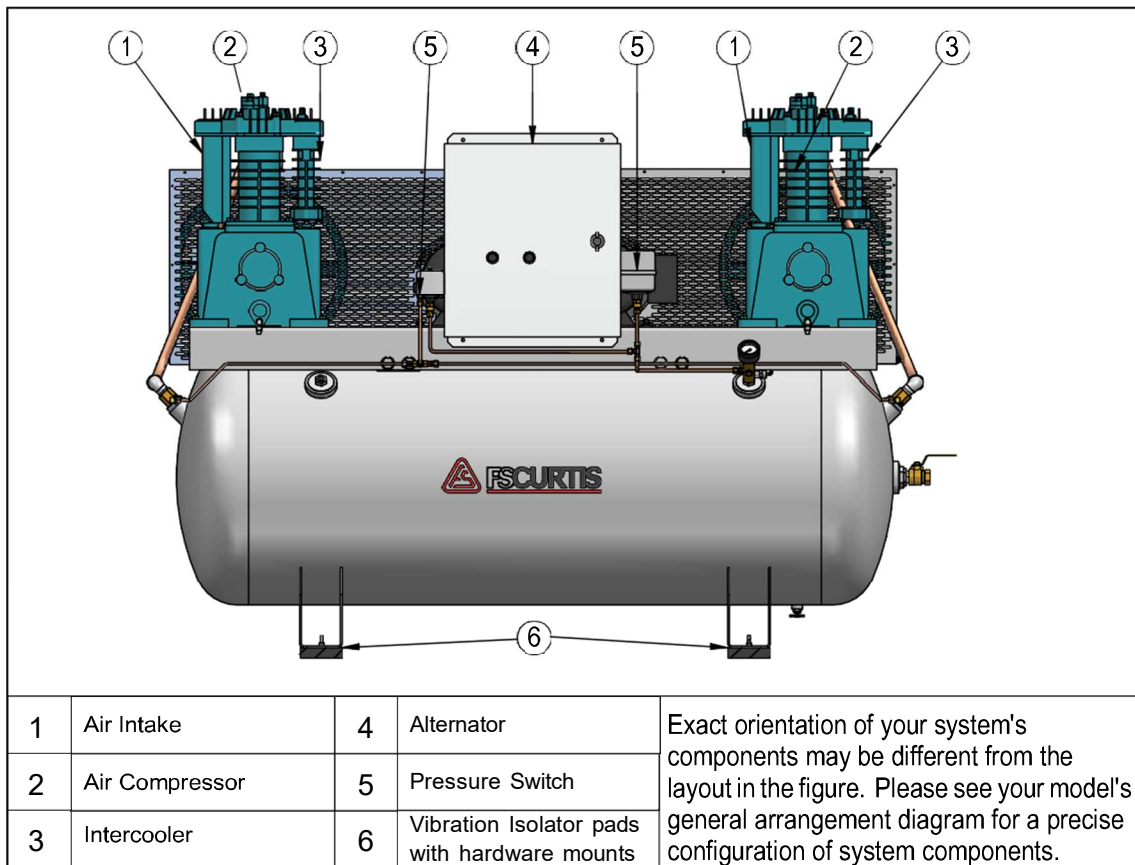

Fig. (2) Duplex unit system diagram.

Refer to the simplex diagram for a description of the compression cycle.

Duplex units operate in much the same way as simplex units, only there are two compressors.

The key difference is in the pressure switch and starter:

In a duplex unit, there are two pressure switches, a “lead” pressure switch on the left hand side of the alternator panel and a “lag” pressure switch set 10 psi lower than the lead switch on the right hand side. The alternator utilizes both compressors to fill the tank. Once the tank approaches the cutoff “lag” pressure, the alternator selects one compressor to be the “lag” compressor and cycles it off, using only the “lead” compressor to provide the remaining pressure. The alternator then cycles between both compressors, switching the “lead” and “lag” compressor and ensuring roughly equal wear between them. If air usage exceeds the output of a single compressor, the alternator utilizes both the “lead” and the “lag” compressor to fulfill operating conditions, once again cycling off the “lag” compressor when its cutoff pressure is reached.

SECTION 2: INSTALLATION

IMPORTANT NOTICE

Abide by all applicable state, local and federal regulations when mounting and installing the compressor. Failure to do so may result in injury or death and will void the manufacturer's warranty. Contact your local government for more information.

CAUTION!

Improper lifting can result in component or system damage or personal injury. Follow good shop practices and safety procedures when moving the unit.

RECEIVING

Immediately upon receipt of compressor equipment and prior to completely uncrating, the following steps should be taken:

1. Inspect compressor equipment for damage that may have occurred during shipment. If any damage is found, demand an inspection from the carrier. Ask the carrier how to file a claim for shipping damages. (Refer to **FREIGHT DAMAGE** for complete details.) Shipping damage is not covered by FS Curtis's compressor warranty.
2. Ensure that adequate lifting equipment is available for moving the compressor equipment and clear a path to the installation location to avoid damage to property or compressor.
3. Turn off & lock out the electrical disconnect switch before working on the unit to prevent the unit from starting unexpectedly.
4. Read the outfit nameplate to verify the model and size ordered.
5. Read the motor nameplate to be sure the motor is compatible with your electrical conditions (volts, phase, and hertz).
6. Read the pressure relief valve nameplate to be sure it does not exceed the working pressure of the compressor or any other component in the system.
7. Read and understand the safety precautions contained within this manual. The successful and efficient operation of compressor equipment depends largely upon the amount of care taken to install and maintain the equipment. FS Curtis strongly recommends that any or all person(s) in charge of installing, maintaining, or servicing one of our compressors read and understand the entire contents of this manual and the respective compressor installation and operating instruction manual in order to perform such duties safely and efficiently.
8. Remove all packing plastic, foam and shipping related materials.

FREIGHT DAMAGE

The transportation industry has adopted a modification with regard to the handling of obvious and concealed damage claims. Therefore, it is extremely important that you examine every carton and crate as soon as you receive it. If there is any obvious damage to the shipping container, have the delivering carrier sign the freights bill, noting the apparent damage, and request a damage report.

If concealed damage is discovered at a later date, the carrier must be notified within 15 days of initial receipt of freight. Contact the carrier as soon as possible, giving them an opportunity to inspect the shipment at the premises where the original delivery was made. Retain all containers and packing for inspection by the carrier. Do not move the freight. Request an inspector and claim number, then contact freight carrier.

Concealed shipping damage is not covered by the FS-Curtis warranty.

A claim form can be requested from the carrier. Your claim will need to be substantiated with the following documents.

- Original bill of lading
- Original paid freight bill
- Original invoice or certified copy
- Other particulars obtainable in proof of loss or damage (photos, damage inspection report, etc.)

We suggest these instructions be circulated to your shipping and receiving personnel.

INSTALLATION PROCEDURE

Step 1 – Select a proper location for installation

Select a clean, dry, well lit area with a rigid floor strong enough to support the compressor and with adequate ventilation. Avoid placement of the compressor in an area that is excessively hot, dusty, humid or contaminated with foreign gases such as ammonia or acid fumes.

The unit should never be operated at ambient temperatures above 104°F or below 32°F. If the ambient temperature is below 40°F, contact FS Curtis to select the appropriate lubricant. FS Curtis recommends using ***FSC-Max Fluids***. Maintenance checks are required daily, thus three (3) feet of space needs to be provided around the compressor for proper inspection.

Note: If the unit or air intake is to be located outdoors, please contact your local distributor for additional instructions.

Step 2 – Remove the skid

Remove and discard the shipping skid. The compressor should NEVER be operated on a skid.

Step 3 – Prepare the mounting surface

See Fig. (3) and Fig. (4) for the compressor’s mounting pattern and prepare the surface accordingly. See Table (2) for acceptable installation methods

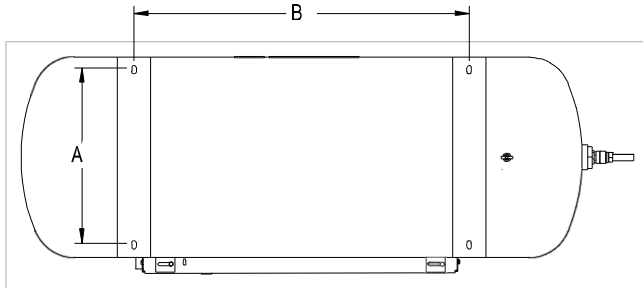

Fig. (3) Horizontal bolt hole pattern

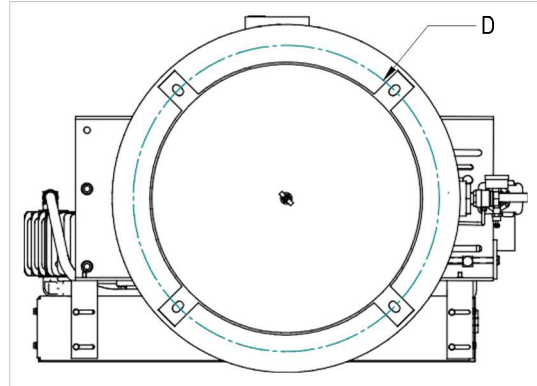

Fig. (4) Vertical bolt hole pattern

Horizontal Tank (gallons)	A (in)	B (in)	Base Hole Size (in)	Recommended Bolt Diameter (in)	Vertical Tank (gallons)	D (in)	Hole Size (in)	Recommended Bolt Diameter (in)
30	17.375	23	9/16	1/2"	60 (3 legs)	23.75	9/16	1/2"
80	17.75	40	9/16	1/2"	80	22.5	9/16	1/2"
120	22	40	9/16	1/2"	120	29.5	5/8	5/8"
200	28	40	7/8	3/4"				
240	40	54	11/16	5/8"				

Table (1) Bolt hole mounting patterns for various tank sizes

Acceptable Mounting	Unacceptable Mounting
<ul style="list-style-type: none"> • Concrete Anchor Bolts • Threaded Rod or Floor Stud • Steel flooring or supports (provided unit is bolted down and isolator pads are used) 	<ul style="list-style-type: none"> • Skid Mounted • Unanchored • Bare Floor (no vibration pads)

Table (2) Compressor mounting methods

If you wish to utilize an installation method other than the approved methods described in Table (2), please contact your local distributor. FS Curtis neither states as fact, nor implies that the above list of Acceptable/Unacceptable mounting is all-inclusive. Contact your local distributor for more information.

Step 4 – Install Vibration Isolator pads and mount the compressor

Exposure to excessive vibrations can significantly shorten the lifetime of the compressor. FS Curtis highly recommends mounting the unit on vibration isolator pads and the compressor should NEVER be operated without being securely fastened to the ground.

Using a level, please check for proper alignment of the compressor. Uneven installation will unbalance the compressor leading to excessive noise, vibrations, and wear. Place a steel shim between the concrete and vibration pads and shim down as necessary for leveling. Level the compressor so it can be bolted down securely. Before tightening the bolts, check to see that all four feet are resting on the foundation. See fig (5) for mounting instructions for a floor stud, and see fig (6) for mounting instructions for an anchor bolt.

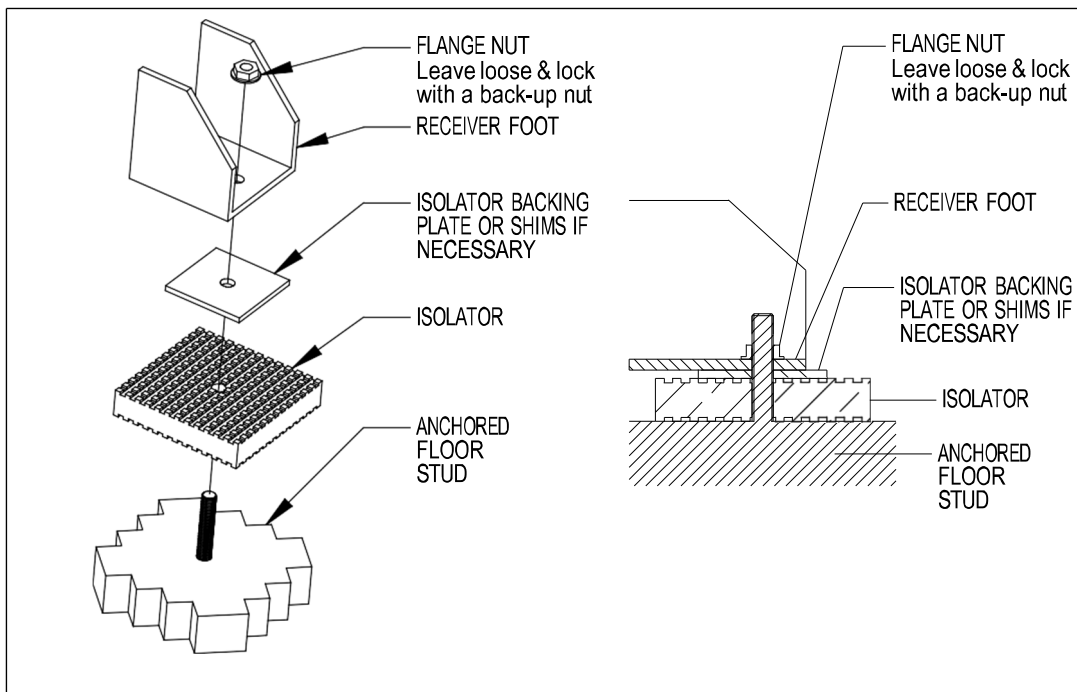

Fig. (5) Anchored Floor Stud installation

Recommended Installation – Use concrete anchor bolt

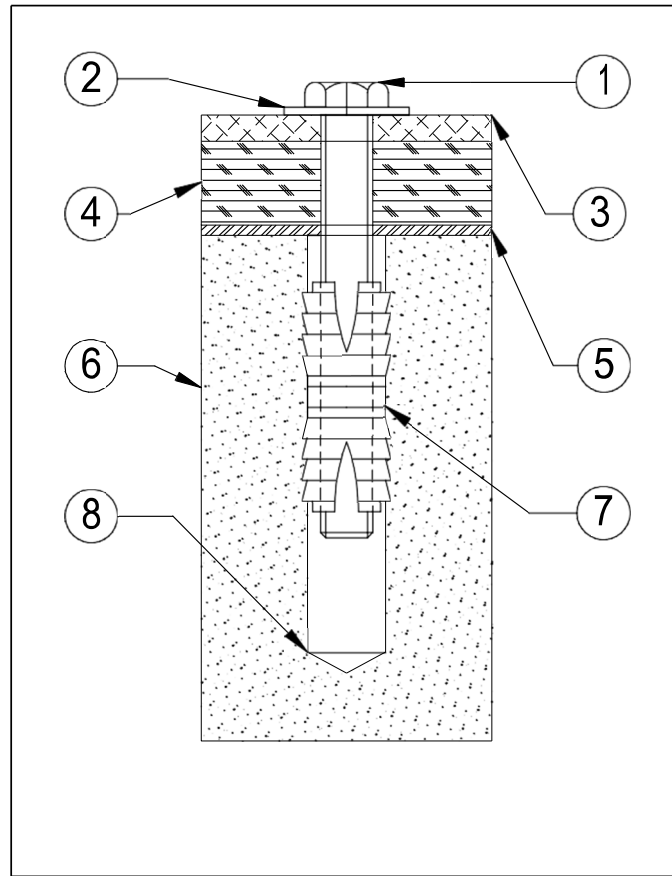

Fig. (6) Recommended Installation Method

1	Mounting bolt
2	Flat washer, sized for bolt
3	Compressor Base
4	Vibration Isolator Pads
5	Steel Shim (as necessary for leveling)
6	Concrete floor, see local codes for recommended concrete thickness and hole drilling depth
7	Heavy duty double expansion machine bolt anchor shield
8	Follow anchor manufacturer recommendations for hole depth

Step 5 – Tighten the fasteners

Incrementally tighten the mounting bolts evenly in a cross pattern. With unit running, continue incrementally tightening the mounting bolts in a crossing pattern until vibrations have been reduced to an acceptable level. After vibrations have been minimized, loosen ONE mounting bolt. The unit expands and contracts with changes in temperature, leaving ONE bolt loosened will allow for thermal expansion of the unit, reducing thermal stresses and vibrations on the tank. If after loosening one bolt the vibrations get worse, retighten bolt and select a different fastener. Excessive vibrations can damage equipment.

Step 6 – Install piping network

Run a clean pipe to the tank discharge opening, bushing up or down as necessary with clean bushings and fittings. Note that the more bushings and fittings placed in the air distribution system, the greater the opportunity for air leaks and breaks. FS Curtis recommends the installation of drip legs in the distribution piping.

Always install a safety relief valve in the distribution line between the compressor unit and in-line shutoff valves. If more than one compressor feeds air into a common air system, a check valve in the distribution line of each compressor unit is recommended to prevent moisture from entering the cylinder head(s) when one compressor is idle. A globe or gate valve (WOG rated) installed in the discharge line will allow compressor isolation from plant air system for compressor maintenance. (Note: A safety relief valve should be located between the compressor and the globe/gate valve.)

Step 7 – Install Compressor Intake (IF APPLICABLE)

If the compressor intake is to be located away from the unit, please use the following instructions to ensure safe and efficient operation.

Run a clean inlet pipe at least the same size (or larger) in diameter as the inlet opening of the compressor, bushing up or down as necessary with clean bushings and fittings. Note that the more bushings and fittings are placed in the intake line, the greater opportunity for air leaks and breaks. For every 10 feet of inlet piping or every 90° bend, increase the inlet piping diameter by one pipe size to prevent excessive pressure drop. When installing the pipes, please pitch the piping down and slightly away from the intake, to ensure that debris and condensation drains away from the compressor.

MOUNTING MOBILE UNITS

Gas engine driven compressors mounted to truck beds should be fastened to the truck bed in such a way so as not to create any stress to the air receiver tank, isolator pads are required for warranty purposes. Truck beds, characteristically, have a tendency to flex and could cause damage to the receiver tank if the tank is fastened directly to the truck bed. It is the User's responsibility to provide an adequate means of fastening the unit in these applications.

POST INSTALLATION CHECKLIST

WARNING!

Failure to perform the post installation checklist may result in mechanical failure, property damage, serious injury or even death.

Steps 1 through 9 should be performed prior to connecting the unit to a power source. If any condition on the checklist is not satisfied, make the necessary adjustments or corrections before starting the compressor.

1. Remove all installation tools from the compressor and check for installation debris. Abrasive dust can seriously damage the air intake and belt assemblies.
2. All FS Curtis compressors are shipped from the factory filled with the required amount of **FSC-Max Fluid** Compressor Lubricant specially formulated for Curtis Compressors. (Basic pumps ship without oil.) The oil level should register in the center of the oil sight glass or between the high and low marks on the dipstick. For additional lubricant contact your authorized Curtis distributor. Failure to use authorized lubricant will void the manufacturer's warranty.
3. Check inlet-piping installation.
4. Check all pressure connections for tightness.
5. Make sure all pressure relief valves in the air distribution are correctly installed.
6. Make sure all guards are in place and securely mounted.
7. Open all manual shutoff valves at and beyond the compressor and tank discharges.
8. Check and tighten all connections (mechanical and electrical) as they may have loosened during shipment.
9. After all the above conditions have been satisfied, the unit can be connected to the proper power source.

ELECTRICAL REQUIREMENTS

The electrical installation of this unit should only be performed by a qualified electrician with knowledge of the National Electrical Code (N.E.C.), O.S.H.A. code and/or any local or state codes having precedence.

All FS Curtis compressors come with a factory installed, pre-wired starter, if you wish to provide your own starter, please contact your local distributor for more information. Check the electrical supply for voltage, phase, and frequency to see that they match the nameplate stampings on the motor, magnetic starter, solenoids, and other controls.

Before attempting to service electrical systems, ensure that maintenance personal are properly qualified, and service procedures comply with NFPA 70-1984, National Electrical Code, National Electrical Safety Code, as well as any applicable state and local regulations. Failure to abide by the national, state and local codes may result in physical harm and/or property damage and will void the manufacturer's warranty.

DANGER!

High voltage may cause personal injury or death, per O.S.H.A. regulations 1910.137, disconnect and lockout/tagout all electrical power supplies before opening the electrical enclosure or servicing.

WARNING!

Never assume a compressor is safe to work on just because it is not currently operating. It could restart at any time. Follow all safety precautions outlined in the Safety Precautions section.

NEMA electrical enclosures and components must be appropriate to the area installed. Safety and efficiency are the primary concerns when selecting components for compressed air systems. Products of inferior quality can not only hinder performance of the unit, but could cause system failures that result in bodily harm or even death. Select only top quality components for your system. Call your local FS Curtis Distributor for quality parts and professional advice.

CAUTION!

Turn off and lockout/tag out the main power disconnect switch before attempting to install the unit.

NOTE: At installation, the customer is to provide disconnect, branch circuit over-current protection, and grounding between the power supply and the electrical control enclosure in accordance with the National Electric Code and/or any local codes.

SECTION 3: WIRING DIAGRAMS

SIMPLEX SINGLE PHASE AND THREE PHASE

TURN OFF / LOCK OUT / TAG OUT POWER BEFORE SERVICING

1	L1
2	L2
3	L3
4	Overload relay
5	Reset switch

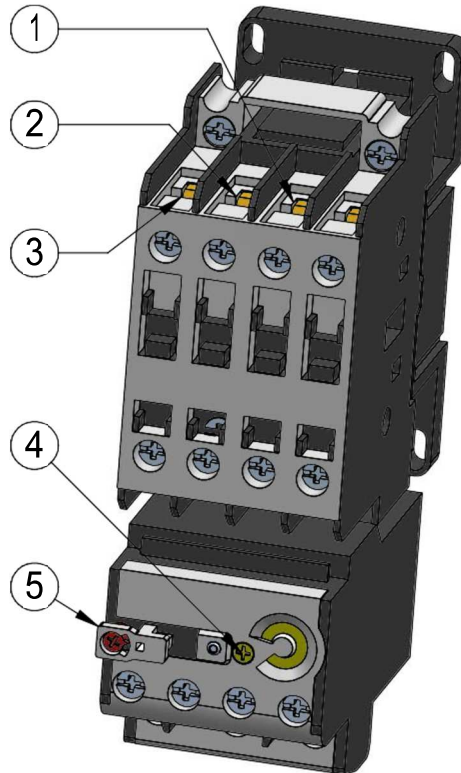

Fig (7) Simplex Starter

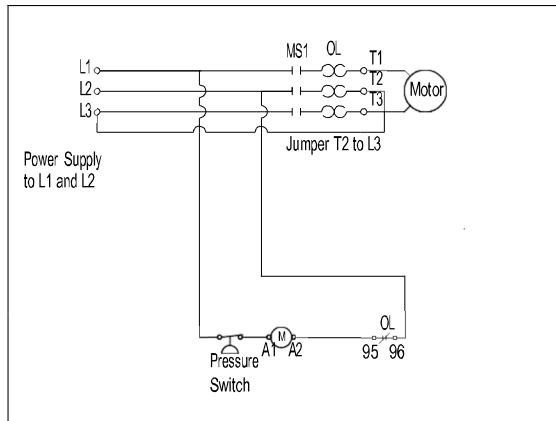

Fig (8) Single Phase wiring diagram

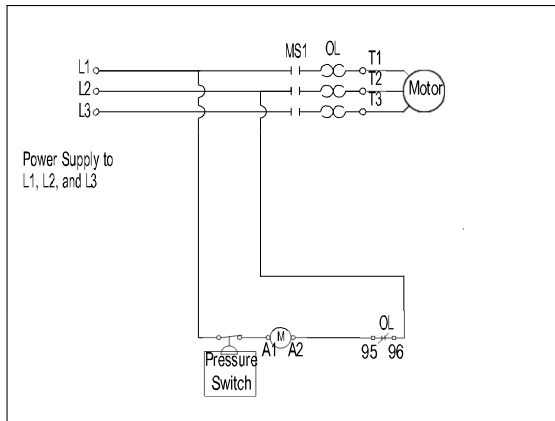

Fig (9) Three phase wiring diagram

DUPLEX DUAL SOURCE ALTERNATOR

TURN OFF / LOCK OUT / TAG OUT POWER BEFORE SERVICING

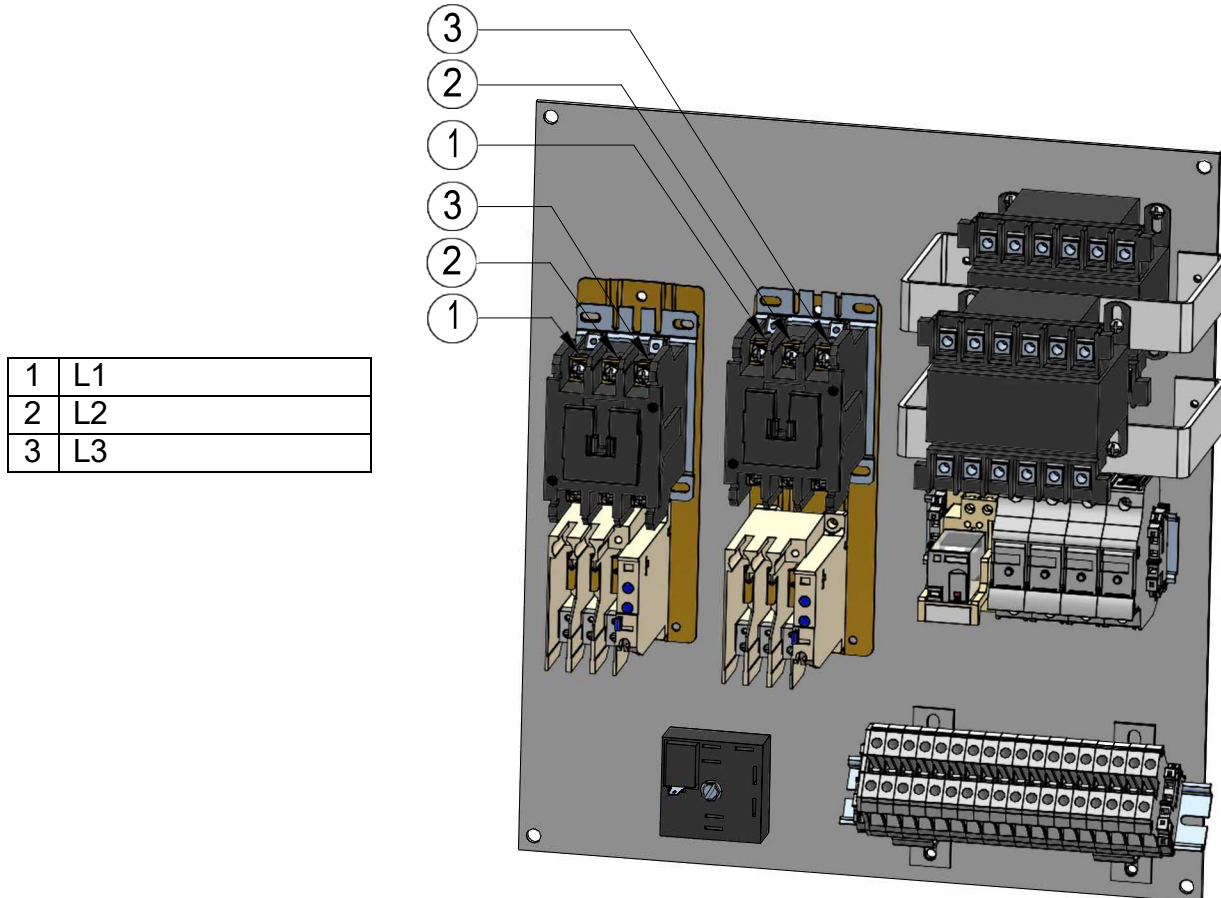

Fig (10) Duplex dual source alternator panel

NOTE: Unit wiring diagram is located on the inside front cover of the alternator panel. If, over time, the diagram becomes illegible, please contact your local distributor.

NOTE: The above wiring diagrams are valid for standard models only. Contact your local distributor for wiring diagrams for factory installed options

SECTION 4: START UP

PRE START CHECK LIST

WARNING!

Do not proceed until the PRE-STARTING CHECKLIST and sub-section has been read and is thoroughly understood.

1. Check oil level in crankcase for proper level.
2. Drain liquid from the air receiver and moisture trap (if so equipped).
3. Check system pressure. Do not operate the compressor in excess of the A.S.M.E. pressure vessel rating for the receiver or the service rating of the compressor, whichever is lower.
4. Jog the starter switch to check the rotational direction of the compressor. The flywheel should rotate in the counterclockwise direction (as viewed when facing the flywheel). Fan blades of the compressor flywheel force ambient air across fins of the intercooler and cylinder heads.
5. Check all pressure relief valves for proper operation.
6. Check control system for proper operation and to ensure all connections (mechanical and electrical) are properly tightened.

INITIAL STARTING & OPERATION

This instruction manual, as well as any instructions supplied by manufacturers of supporting equipment, should be read and understood prior to starting the compressor. If there are any questions regarding any part of the instructions, please contact your local FS Curtis distributor.

With the pre-starting checklist completed and satisfied, close the disconnect switch and start the compressor (for electric units) or engage the starter (for gas units). Watch and listen for excessive vibration and unusual noises. If either exists, stop the compressor, determine and correct the problem before re-starting.

Observe compressor operation closely for the first eight hours of operation. If any abnormal conditions are witnessed, stop the compressor and correct the problem. After two days of operation check belt tension, oil level, and inspect the system for leaks. Additionally, all electrical connections and mechanical fasteners should be checked for tightness and torqued as needed.

In the first weeks, the compressor needs time to “break in.” The belt requires time to stretch and fit into the surface of the pulleys. The piston rings need time to seat themselves into the cylinder walls, and bearings need to wear into place. For the first 100 hours or so, the compressor will consume higher than normal amounts of oil until the break in process is complete.

FIRST MONTH MAINTENANCE

- Check oil level at the beginning of every week, fill as needed, see oil subsection.
- Check belt tension at the beginning of each week and tighten as required, see belt tension subsection.
- Check bolts, pulley clamp screws, and jam nuts for tightness. Torque if necessary (see bolt torques subsection)

START-UP

If the compressor is equipped with an automatic start-stop control (with pressure switch unloading), it is automatically unloaded upon starting, and will automatically load after attaining running speed. Simply operate the power switch to start the unit.

All gas units are equipped with pilot valve controls and should be manually unloaded prior to start up. To manually unload the compressor in order to achieve an unloaded start, release the pilot valve lever BEFORE starting the compressor.

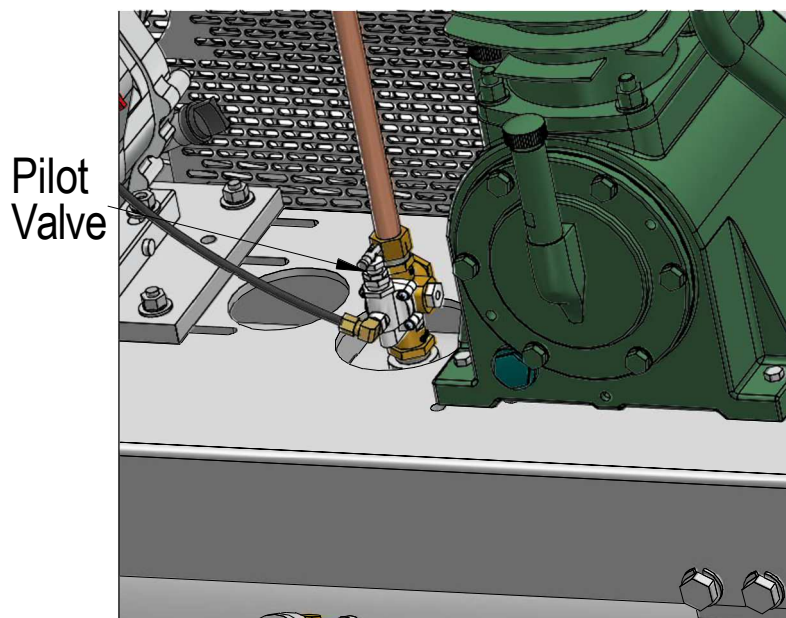
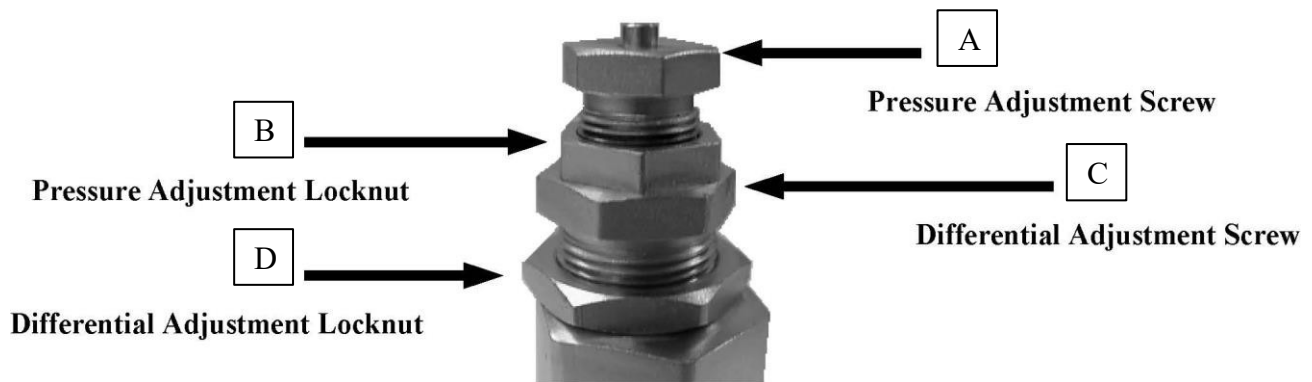

Fig (11) Pilot valve location

PILOT VALVE ADJUSTMENT PROCEDURE

1) Identify the components of the pilot valve adjustment labeled below. The same terms will be used throughout the instructions. Two important terms must be defined. The **unload setting** is the maximum pressure the pilot valve allows the receiver to reach before unloading the unit. The **load setting** is the minimum pressure the pilot valve allows the receiver to reach before loading the unit.



2) Drain all the air from the system and make sure that the relief valve is intact.

Note: Maximum unload setting of the pilot valve should not exceed 90% of the relief valve setting. Loosen both the differential and pressure adjustment locknuts completely. Then, gently turn the differential screw **clockwise** until it stops.

WARNING: DO NOT OVER TIGHTEN THE DIFFERENTIAL SCREW OR THE SEAT OF THE VALVE COULD BE DAMAGED.



3) Remove the pressure adjustment screw from the body of the valve. Remove pressure adjustment screw and locknut together.



4) Reinstall the pressure adjustment screw by turning it two full turns.



5) Restart the compressor. Increase the pressure until the desired load pressure has been reached. Turn off the compressor.

6) Back off the differential screw 1/3 of a turn in the **counterclockwise** direction. Tighten the differential locknut. Backing off the differential screw allows the valve to actuate unloading devices as it would in normal operation.

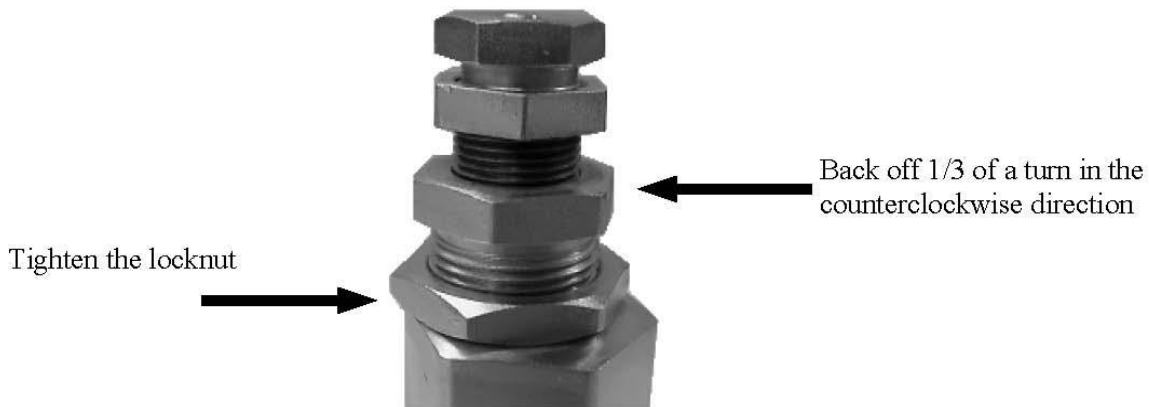

7) While the unit is at the desired load pressure, slowly turn the pressure adjustment screw in the **clockwise** direction. As you are turning the valve, listen for the valve to load. It will exhaust air from the top of the valve body and make a hissing noise. Once this happens, tighten the pressure adjustment locknut.

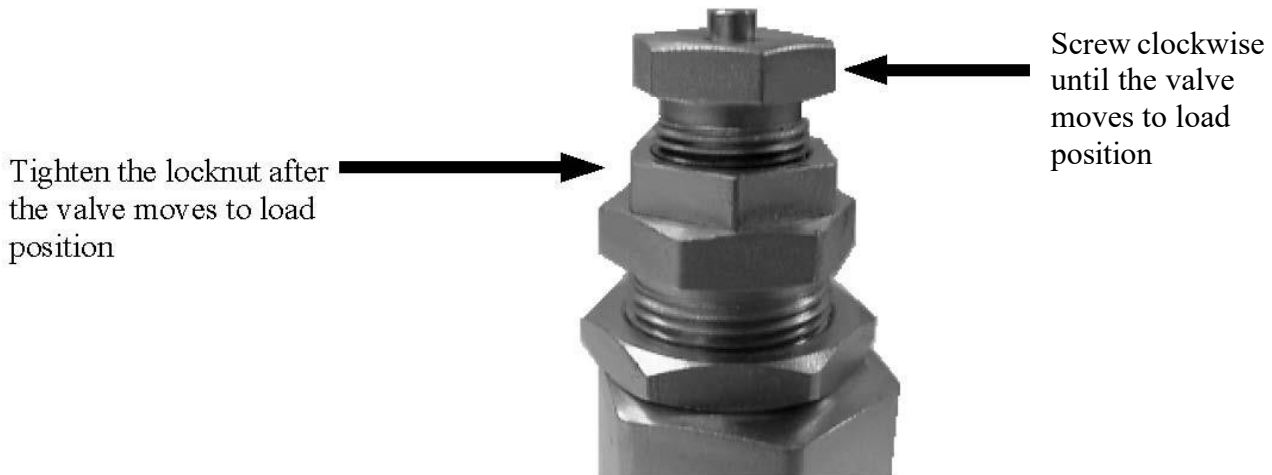

FINE ADJUSTMENT:

Because of actual operating conditions fine adjustment (tuning) of the setting may be required. Cycle the Pilot Valve several times through the load and unload set points to insure repeatability.

- 1) **To fine tune the LOAD SET POINT:** Loosen lock nut “B” and turn the pressure adjustment nut “A” clockwise to increase the LOAD PRESSURE and counter-clockwise to decrease the LOAD PRESSURE. This is a fine adjustment and should only be made in small increments. (Turn 1/2 to 1 wrench flat at a time)
- 2) **To adjust the UNLOAD SET POINT:** Loosen lock nut “D” and turn the differential adjusting nut “C” clockwise to increase the unload pressure set point and counter-clockwise to decrease the unload set point. This is a fine adjustment and should only be made in small increments. (Turn 1/2 to 1 wrench flat at a time)
- 3) **If the valve chatters in the UNLOAD MODE:** The differential setting is too narrow. Turn the adjusting nut “C” clockwise until the chattering stops and the valve unloads properly.
- 4) **If the valve does not unload and there is SEVERE BLOWING through the stem:**
This indicates that the differential is too wide. Turn the differential adjusting nut “C” counter-clockwise until the valve unloads properly.

SECTION 5: MAINTENANCE

SHUT DOWN PROCEDURE

The following procedures should be followed when stopping the compressor for maintenance or service.

WARNING!

Never assume a compressor is safe to work on just because it is not operating. It could start at any time.

1. Per O.S.H.A. regulation 1910.147; The Control of Hazardous Energy Source (Lockout/Tag out); disconnect and lockout/tag out the main power source. Display a sign in clear view at the main power switch that the compressor is being serviced.
2. Isolate the compressor from the compressed air supply by closing the manual shutoff valve upstream and downstream from the compressor. Display a sign in clear view at the shutoff valve stating that the compressor is being serviced.
3. Lock open a pressure relief valve within the pressurized system to allow the system to be completely de-pressurized. **NEVER** remove a plug to relieve the pressure.
4. Open all manual drain valves within the area to be serviced.
5. Wait for the unit to cool before starting to service. (Temperatures of 125°F can burn skin. Some surface temperatures exceed 400°F when the compressor is operating.)

MAINTENANCE SCHEDULE

DESCRIPTION	DAILY	WEEKLY	MONTHLY	3 MONTH	6 MONTH	9 MONTH	1 YEAR
Check oil level	•						
Check pressure operating point and controls	•						
Drain condensate from air receiver	•						
Manually operate the pressure relief valves		•					
Check the compressed air distribution systems for leaks		•					
Inspect tubing for signs of wear		•					
Inspect belt tension		•					
Clean the cooling surface of the intercooler and compressor		•					
Inspect bolts, pulley clamp screws and jam nuts for tightness			•				
Check all connections (mechanical & electrical) for tightness			•				
Inspect anti-vibration pads			•				
Change air filter					•*		•*
Change oil				• ^{1*}	• ^{1*}	• ^{1*}	• ^{1*}
Inspect valves for rust, wear and carbon build up				•	•	•	•

Notes:

- 1) Change oil every three months or 500 h, whichever occurs first. When using **FSC-Max Fluids** this interval can be extended to six months or every 1000 h, whichever comes first. Lubricant may require more frequent changes depending on operating environment and running conditions. .
 - 2) Do not tamper with safety valve setting - it is factory set - only check operation! Tampering will void warranty and result may cause severe injury or death
- * The maintenance intervals described herein are for normal operating condition in clean and well ventilated environments. Frequency of intervals will increase for non-standard environments. Please contact your authorized FS-CURTIS distributor for more information and recommendations

OIL

OIL RECOMMENDATION

Use Genuine **FSC-Max Fluids** which are specially formulated for FS Curtis Reciprocating Air Compressors. **FSC-Max Fluids** are non-detergent type lubricants with anti-foam, anti-rust and oxidation inhibitors.

Under normal operating temperatures, use **FSC-Max Fluids** ISO68 FSC-1000.

In areas with very hot ambient air temperatures, FS Curtis recommends using **FSC-Max Fluids** ISO100 FSC-1000A.

1. For proper lubrication the compressor shall not be operated below the minimum or above the maximum R.P.M. recommended for the various models.
2. Maintain oil level mid-way between the upper and lower lines of the crankcase sight gage.

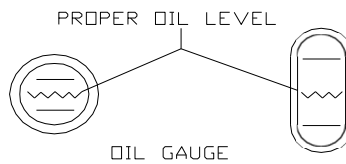

Fig (12) Oil sight glass reading

3. Stop compressor to add and gauge oil.
4. Do not fill above the upper line and do not operate compressor with oil level below the lower line.

OIL CAPACITIES

MODEL NUMBER	HORSEPOWER (hp)	MIN RPM	MAXIMUM RPM	OIL CAPACITY
E50	5	500	1050	1½ QUARTS
E57	5 – 7½	800	1250	2 QUARTS
E71	10	500	1050	2½ QUARTS
E15	15	500	1050	5 QUARTS

Table (4)

LOW OIL GUARD

To help prevent catastrophic damage, FS Curtis provides an option for a Low Oil Guard, which prevents the unit from starting when the oil level has dropped below the low oil mark on the sight glass or dipstick, see Fig (12) for proper oil level. FS Curtis's low oil guard utilizes a magnetic float switch which is rated for 250VAC maximum and 24VDC maximum, higher voltages will require a control power transformer.

CAUTION!

A low oil guard is not a substitute for proper maintenance. Continue to perform regular oil changes at the intervals stated in this manual.

WARNING!

Never assume a compressor is safe to work on just because it is not currently operating. It could restart at any time. Follow all safety precautions outlined in the Safety Precautions section. Turn off and lockout/tag out the main power disconnect switch before attempting to perform maintenance on the unit.

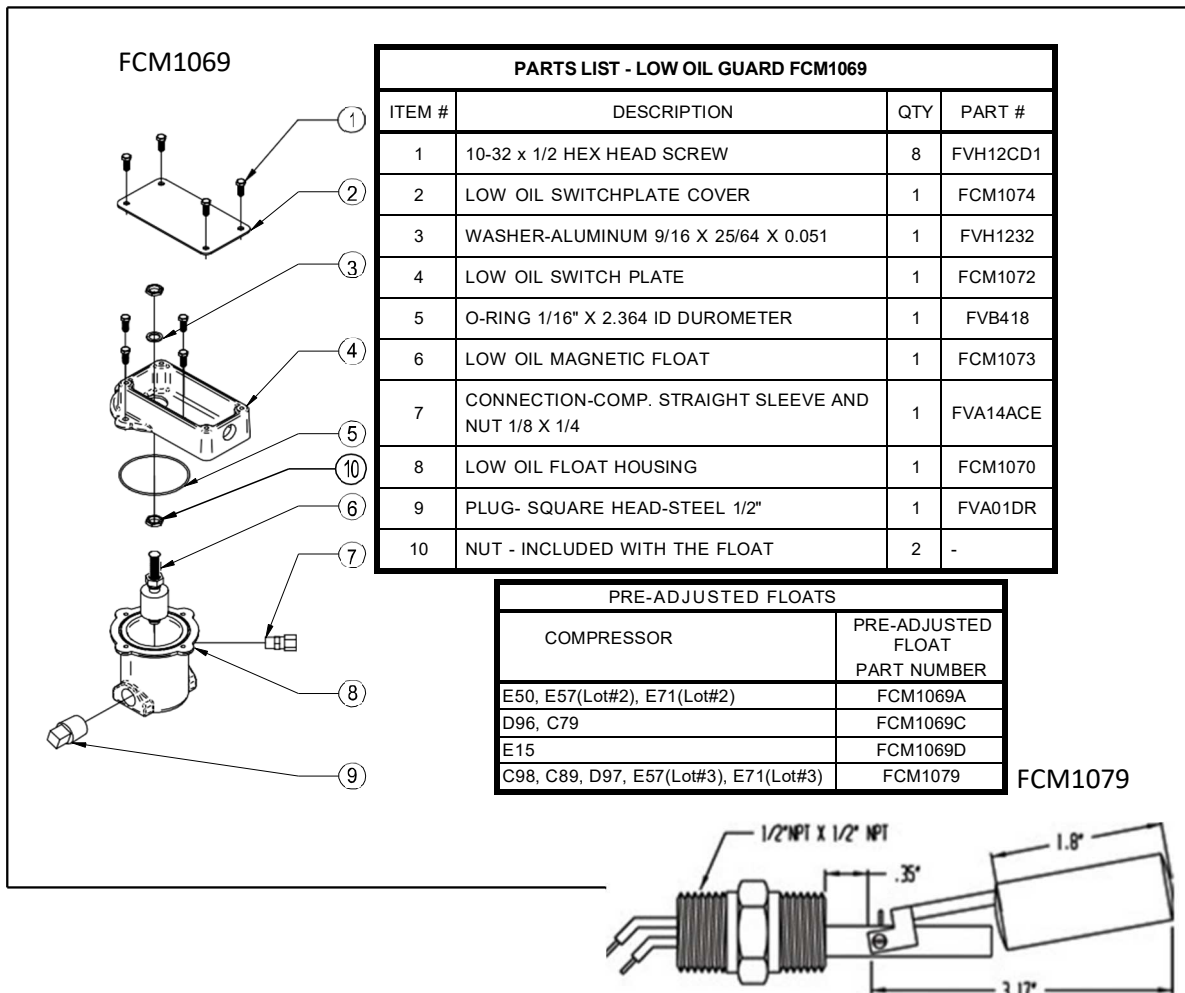

Fig (13) Low Oil Guard assembly.

BOLT TORQUES

	E50		E57		E71		E15	
	Size	Torque (CM-FT)	Size	Torque (CM-FT)	Size	Torque (CM-FT)	Size	Torque (CM-FT)
Head Bolts	M10-1.5	300-21.7	M10-1.5	320-23.1	M10-1.5	320-23.1	M10-1.5	320-23.1
Cylinder Case	M10-1.5	280-20.35	M10-1.5	280-20.25	M10-1.5	280-20.25	M10-1.75	350-25.3
Rod Bolts	M8-1.5	280-20.25	M8-1.25	280-20.25	M8-1.5	300-21.7	M10-1.5	300-23.1
Front Cover	M8-1.5	280-20.25	M10-1.5	300-21.7	M8-1.5	300-21.7	M10-1.5	320-23.1
Rear Cover	M10-1.5	280-20.25	M8-1.25	300-21.7	M10-1.5	280-20.25	M10-1.5	280-20.25
Inlet and Outlet Push Covers	M8-1.25	225-16.3			M8-1.25	225-16.3	M10-1.5 M8-1.25	320-23.1 225-16.3

Table (5) Challenge air bolt torque specifications

MODEL NO.	FLYWHEEL BOLTS		FAN BOLTS	
	TORQUE FT.-LBS.	TORQUE IN.-LBS.	TORQUE FT.-LBS.	TORQUE IN.-LBS.
E57	23	276	-	-
E50	40	480	-	-
E71	45	540	24	288
E15	50	600	24	288

Table (6) Challenge air bolt torque specifications

BELT TENSION

CAUTION!

Over tightening the v-belt(s) will result in overloading of the motor, and/or belt and pulley failure. A loose belt will result in an unstable speed, premature belt wear, “throwing” belts and a high amp draw.

To change tension, follow the instructions outlined below. Grease both the motor and compressor pulleys once a year with lithium ball bearing grease.

Proper belt tensioning requires the use of a belt tension gauge to measure belt tension. This tool is available at your local auto parts or hardware store.

1	Motor mounting bolts (x4)
2	Take-up bolt

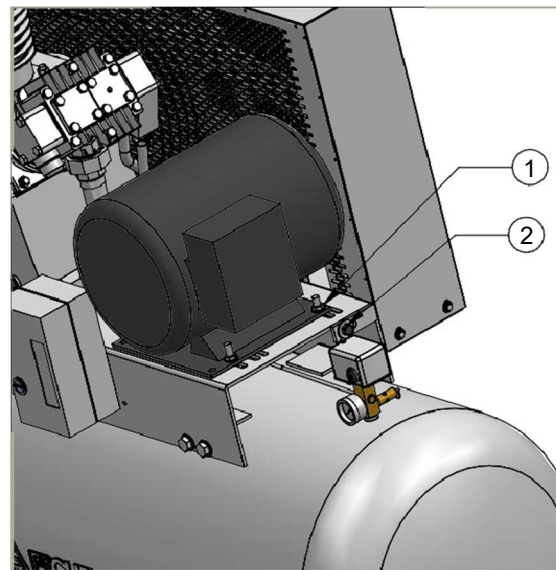

Fig (14) Motor mounting bolts and take-up bolt.

BELT TENSIONING INSTRUCTIONS

1. Loosen all 4 motor mounting bolts (1), but do NOT remove the nuts. **Do NOT attempt to adjust the take-up bolt before loosening all of the motor mounting bolts, attempting to do so will damage the unit.**
2. Consult Table (8) for the appropriate deflection and tension values for Challenge Air units.

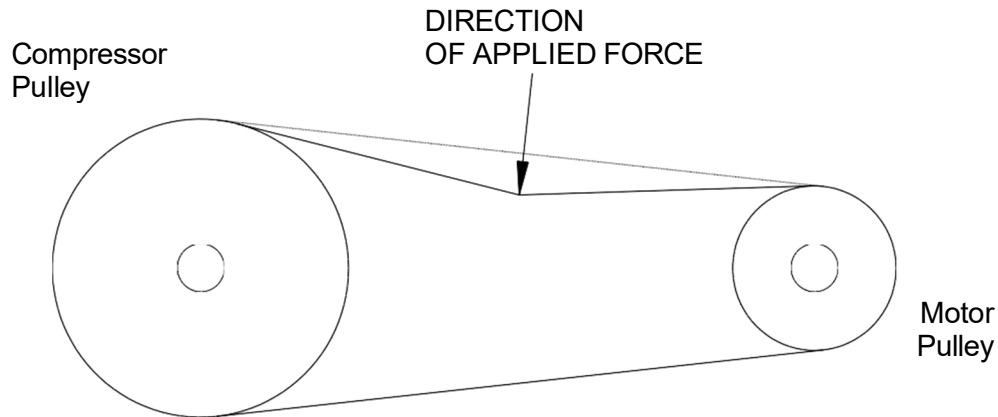

Fig (15) Proper belt tensioning

3. At the center of the span, perpendicular to the belt, apply pressure to the outer surface of the belt tension gauge as shown in figure (15). Apply force to the belt until the rubber ring on the deflection gauge is located at the original position of the belt. Record the reading on the belt tension gauge and compare to the chart. Reset the rubber ring on the belt tension gauge before taking another reading.
4. Adjust the take-up bolt to tighten or loosen the belt tension as required.
5. Finger-tighten ONE motor mounting bolt. Using a straight-edge, make sure that pulleys are aligned and adjust motor as necessary.
6. Finger-tighten the remaining motor mounting bolts.
7. Using a wrench or air tool, incrementally tighten the mounting bolts in a basic crossing pattern.
8. Re-mount the belt guard. DO NOT attempt to operate the unit without the belt guard securely in place.
9. Recheck the tension of the new belts several times in the first month of operation and adjust if necessary. Thereafter, check belt tension every three months.

BELT TENSIONING VALUES

Model	HP	Gage Deflection	Average Tension	Minimum	Maximum
CA E57	5	1/4"	10lb	9lb	12lb
CA E50	5	1/4"	10lb	9lb	12lb
CA E57	7.5	1/4"	8lb	7lb	10lb
CA E71	10	3/8"	12lb	11lb	14lb
CA E15	15	3/8"	11lb	10lb	13lb
CA Gas E57	13-14	3/8"	20lb	18lb	23lb

Table (8) Challenge Air Belt Tensioning Guide

MAINTENANCE PARTS AND REBUILD KITS

To order replacement parts for routine maintenance, please contact your local distributor.

	<i>E57 Kit Number</i>	<i>E50 Kit Number</i>	<i>E71 Kit Number</i>	<i>E15 Kit Number</i>
Oil (12 quart case)	FSC-1000-12	FSC-1000-12	FSC-1000-12	FSC-1000-12
Air Filter	2601540300	2601540410	2601540410	2601540410
Gasket Kit (all gaskets)	FSK-E57GK	FSK-E50GK	FSK-E71GK	FSK-E15GK
Breather Kit (oil breather)	FSK-E57OLBK	FSK-E50OLBK	FSK-E71OLBK	FSK-E15OLBK
Valve/Gasket Kit (wearable parts)	FSK-E57VK	FSK-E50VK	FSK-E71VK	FSK-E15VK
Piston Ring Kit (all rings)	FSK-E57RNG	FSK-E50RNG	FSK-E71RNG	FSK-E15RNG
Lower End Kit (contains Gasket Kit, Valve Kit, and Ring Kit)	FSK-E57LERK	FSK-E50LERK	FSK-E71LERK	FSK-E15LERK
1000 Hour Service Kit (Oil and element replacement)	FSK-E5710SK	FSK-E5010SK	FSK-E7110SK	FSK-E1510SK

Table (9) Routine Maintenance Parts and Rebuild Kits for Challenge Air compressors

SECTION 6: TROUBLESHOOTING

	Problem	Cause	Remedy
1	Unit won't start	<ul style="list-style-type: none"> • Power not on • Fuse blown • Low voltage supplied • Worn pressure switch contacts • Starter overload tripped • Broken / loose electrical connections 	<ul style="list-style-type: none"> • Check breaker and / or disconnect • Replace the fuse or disconnect • Contact distributor • Replace • Reset starter overload • Check electrical connections
2	Flywheel / motor rotating clockwise	<ul style="list-style-type: none"> • Incorrect lead connection 	<ul style="list-style-type: none"> • Reverse leads L1 and L2
3	Flywheel / motor rotating slowly	<ul style="list-style-type: none"> • Excessively dirty oil • Heavy lubrication oil • Oil thick due to low temperature • Belt slipping • Incorrect voltage 	<ul style="list-style-type: none"> • Change the oil • Use correct oil • Increase ambient temperature above 40°F • See 6 • Contact distributor
4	Excessive Vibrations	<ul style="list-style-type: none"> • Vibration pads not installed • Unit not leveled • Unit not securely fastened 	<ul style="list-style-type: none"> • Install vibration pads • Level unit with metal shims • Check for loose bolts on foundation, compressor, and motor
5	Compressor overheats	<ul style="list-style-type: none"> • Ambient air temperature too high • Degraded oil • Incorrect oil • Clogged Air Intake • Interior or exterior fouling of the intercooler 	<ul style="list-style-type: none"> • Ensure adequate ventilation • Change oil • Use correct oil • Replace filter and clean intake • Clean intercooler
6	Belt slipping	<ul style="list-style-type: none"> • Working pressure too high • Low belt tension • Worn belt • Incorrect belt • Worn or misaligned pulley 	<ul style="list-style-type: none"> • Lower working pressure • Adjust belt tension • Replace • Install correct belt • Replace or align pulley

	Problem	Cause	Remedy
7	Low discharge pressure	<ul style="list-style-type: none"> • Manual drain not fully closed (standard model) • Automatic drain not fully closed (if applicable) • Clogged air filter / intake • Leaks in air distribution system • Clogged air distribution system • Worn out pressure switch • Belt slipping • Worn piston rings • Worn head gasket • Worn valves 	<ul style="list-style-type: none"> • Close the drain cock • Clean or replace automatic drain • Replace the filter • Check fittings, bushings and connections for leaks • Clean air distribution system • Replace pressure switch • See 6 • Replace with ring kit • Replace with gasket kit • Replace with valve kit
8	Excessive belt wear	<ul style="list-style-type: none"> • Belt too tight or too loose • Incorrect belt • Exposure to abrasive dust • Working pressure too high • Worn or misaligned pulley 	<ul style="list-style-type: none"> • Adjust belt tension • Use correct belt • Eliminate dust or relocate unit • Lower working pressure • Replace or realign pulley
9	Lubricant appears milky	<ul style="list-style-type: none"> • Water in the crankcase • Incorrect oil • Water contaminated oil • Water leaking back through discharge valve 	<ul style="list-style-type: none"> • Compressor not running long enough to prevent condensation • Use correct oil • Replace oil • Re-pipe with drip legs and pitch piping away from the compressor
10	Excessive oil in compressed air	<ul style="list-style-type: none"> • Oil level too high • Incorrect oil • Piston ring not fully seated • Worn piston ring 	<ul style="list-style-type: none"> • Bleed excess oil • Use correct oil • Allow 100 hours to break in rings • Replace with ring kit
11	Motor overloads	<ul style="list-style-type: none"> • Working pressure too high • Incorrect voltage 	<ul style="list-style-type: none"> • Lower working pressure • Contact distributor

If your problem is not resolved after performing troubleshooting, or not listed above, please contact your local distributor for further assistance.

MAINTENANCE CHECK LIST (CONTINUED)

VALVES INSPECTED

Initials	Date Checked	Initials	Date Checked

AIR LEAK CHECK

Initials	Date Checked	Comments	Initials	Date Checked	Comments

AIR FILTER

Initials	Date Replaced	Initials	Date Replaced

INTER COOLER / AFTER COOLER CLEANING

Initials	Date Checked	Initials	Date Checked

NOTES



Curtis-Toledo, Inc.

1905 Kienlen Avenue | St. Louis, Missouri 63133

314-383-1300 or 800-925-5431

www.fscurtis.com | info@fscurtis.com