

FEATURES

- Suitable for Industrial use
- Dual bypass port
- Extremely reliable
- Easy maintenance



ZH284



ZH284K

SPECIFICATIONS

Part Number	ZH284	ZH284K
Max Volume*	10.5 GPM	
Max Operating Pressure	4060 PSI	
Max Temperature	194° F	
Port Sizes	Inlet:	(2) 3/8" NPT-F
	Outlet:	3/8" NPT-F
	Bypass:	(2) 3/8" NPT-F
Dimensions	7.01" x 3.31" x 2.05"	
Weight	2.87 lbs	
Knob	No	Yes

General Pump recommends using a pressure reducing device in conjunction with this unloader valve when installed on a positive displacement pump. General Pump is not liable and assumes no responsibility when used in a customer's high pressure system.

*NOTE: If unloader is fed through the lower connection max flow rate: 7.9 GPM / 30 l/min

PARTS LIST ZH284

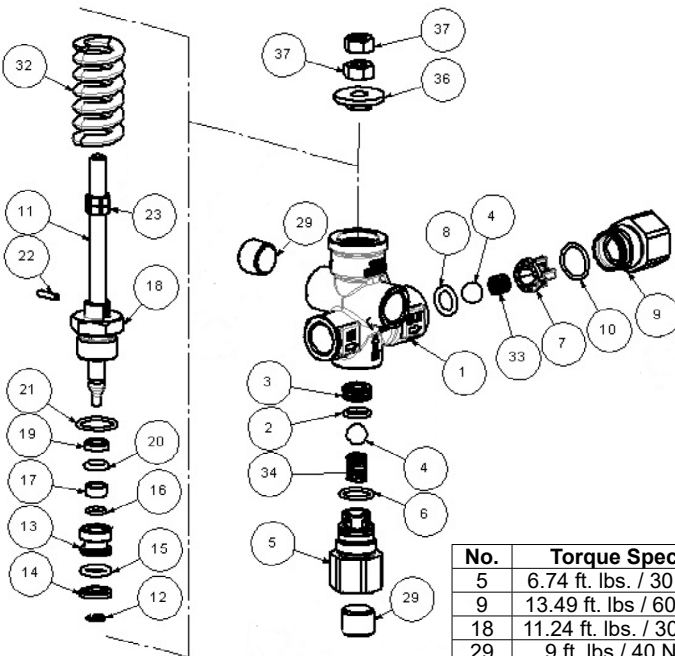

No.	Torque Specs
5	6.74 ft. lbs. / 30 Nm
9	13.49 ft. lbs. / 60 Nm
18	11.24 ft. lbs. / 30 Nm
29	9 ft. lbs. / 40 Nm

No.	Part No.	Description	Qty.
1	36359741	Housing	1
2*	90358500	O-ring, Ø 10.82 x 1.78	1
3*	36326566	Seat	1
4*	97483800	Ball, 13/32" (10.319 mm)	2
5	36359270	Inlet Nipple, 3/8" NPT-F	1
6*	90359100	O-ring, Ø 14 x 1.78	1
7*	36310451	Valve Guide	1
8*	90382300	O-ring, Ø 9.92 x 2.62	1
9	36359070	Outlet Nipple, 3/8" NPT-F	1
10*	90359300	O-ring, Ø 15.6 x 1.78	1
11	36359573	Piston Rod	1
12*	90006300	Anti-Extrusion Ring, D.8 - DF. 1.2	1
13	36326466	Piston Guide	1
14*	90507000	Anti-Extrusion Ring, Ø 11.6 x 16 x 1.5/2	1
15*	90382500	O-ring, Ø 10.78 x 2.62	1
16*	90357600	O-ring, Ø 6.75 x 1.78	1
17	36335770	Spacer	1
18	36335670	Piston Rod Bushing	1
19*	90503600	Anti-Extrusion Ring, Ø 8 x 12.4 x 2.5/3	1
20*	90381800	O-ring, Ø 7.59 x 2.62	1
21*	90359500	O-ring, Ø17.17 x 1.78	1
22	97665800	Plug, Ø 3 x 12	1
23	36358970	Nut, M08 x 4.5	2
29	98209430	Plug, 3/8" NPT x 12.7	2
32*	94750700	Spring, Ø 21 x 53	1
33	94735500	Spring, Ø 8.5 x 12	1
34	94736000	Spring, Ø 8.6 x 16.5	1
36	36359870	Spring Plate	1
37	92222300	Nut, M8-8	1
*	K421	Repair Kit	

PARTS LIST ZH284K

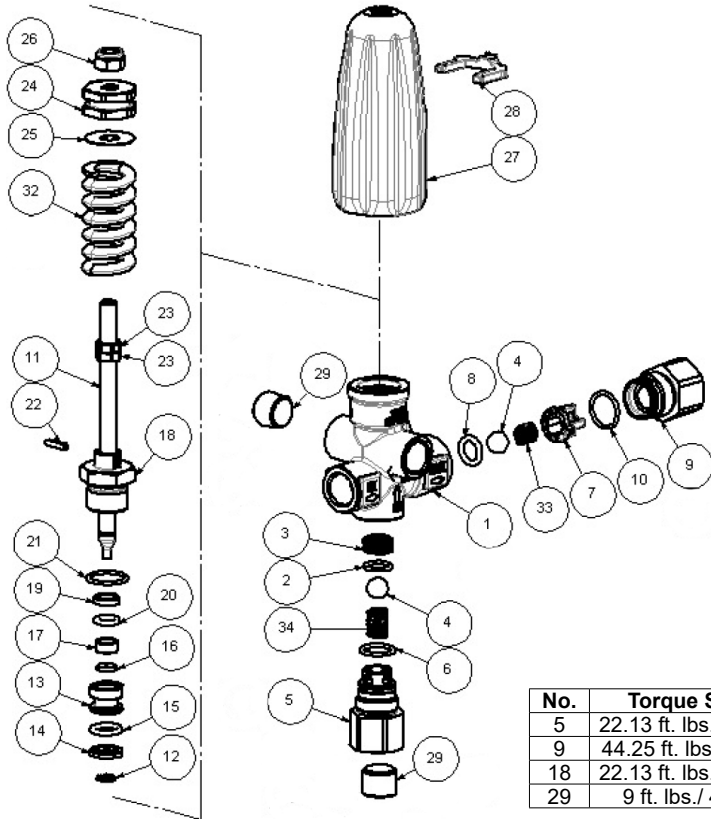

No.	Part No.	Description	Qty.
1	36359741	Housing	1
2*	90358500	O-ring, Ø 10.82 x 1.78	1
3*	36326566	Seat	1
4*	97483800	Ball, 13/32" (10.319 mm)	2
5	36359270	Inlet Nipple, 3/8" NPT-F	1
6*	90359100	O-ring, Ø 14 x 1.78	1
7*	36310451	Valve Guide	1
8*	90382300	O-ring, Ø 9.92 x 2.62	1
9	36359070	Outlet Nipple, 3/8" NPT-F	1
10*	90359300	O-ring, Ø 15.6 x 1.78	1
11	36359573	Piston Rod	1
12*	90006300	Anti-Extrusion Ring, D.8 - DF. 1.2	1
13	36326466	Piston Guide	1
14*	90507000	Anti-Extrusion Ring, Ø 11.6 x 16 x 1.5/2	1
15*	90382500	O-ring, Ø 10.78 x 2.62	1
16*	90357600	O-ring, Ø 6.75 x 1.78	1
17	36335770	Spacer	1
18	36335670	Piston Rod Bushing	1
19*	90503600	Anti-Extrusion Ring, Ø 8 x 12.4 x 2.5/3	1
20*	90381800	O-ring, Ø 7.59 x 2.62	1
21*	90359500	O-ring, Ø 17.17 x 1.78	1
22	97665800	Plug, Ø 3 x 12	1
23	36358970	Nut, M08 x 4.5	2
24	36352670	Pressure Register	1
25	36352700	Spring Holder Ring	1
26	872011054	Nut, M8	1
27	36326051	Knob	1
28	36329751	Yoke	1
29	98209430	Plug, 3/8" NPT x 12.7	1
32*	94750700	Spring, Ø 21 x 53	1
33	94735500	Spring, Ø 8.5 x 12	1
34	94736000	Spring, Ø 8.6 x 16.5	1
*	K421	Repair Kit	

DIMENSIONS ZH284

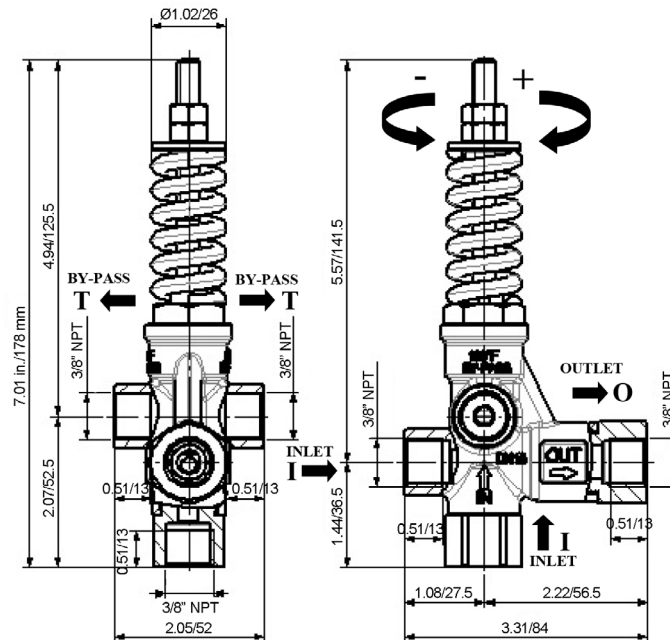

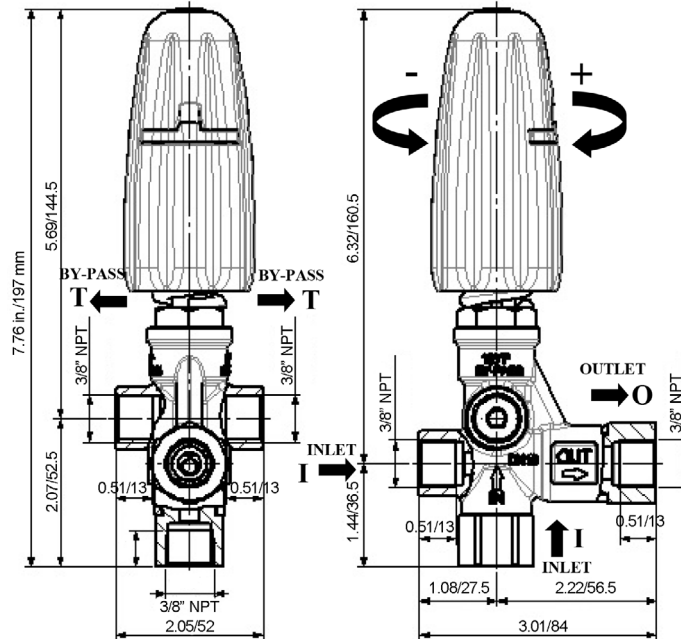
DIMENSIONS ZH284K**INSTALLATION AND INSTRUCTIONS FOR USE**

THIS DOCUMENT PROVIDES THE INSTRUCTIONS FOR THE INSTALLATION, USE AND MAINTENANCE OF THE VALVE, THEREFORE IT IS AN INTEGRAL PART OF THE VALVE ITSELF AND MUST BE READ CAREFULLY BEFORE ANY USE AND KEPT WITH CARE. STRICTLY COMPLY WITH THE INSTRUCTIONS CONTAINED IN THIS DOCUMENT IN VIEW OF A SAFE AND EFFECTIVE USE OF THE VALVE. FAILURE TO COMPLY WITH THESE INSTRUCTIONS MIGHT CAUSE EARLY FAULTS AND RESULT IN SITUATIONS OF DANGER, IN ADDITION TO VOIDING ANY WARRANTY.

1-GENERAL INFORMATION:

1.1 - The ZH284/ZH284K automatic pressure regulator is a manually-adjustable, pressure-operated device which, according to its setting, limits the pump/system pressure by conveying the excess of water to the by-pass. Moreover, when the outlet flow is blocked, this device totally releases the flow - and keeps under pressure the portion of the system following the valve, while it sets the pressure to zero in the portion of the system preceding the valve.

2-WARNINGS:

2.1 - To ensure the tightness of the fittings used to connect the valve to the system, interpose a metal washer with a rubber ring or insert an appropriate sealing on the thread and tighten them.

2.2 - Use guns or other control devices ensuring a perfect seal when closed. Leakages may compromise the correct functioning of the valve.

2.3 - **WARNING: Max. flow rate not exceeding 7.95 GPM (30 L/min) if the valve is fed through the lower INLET fitting.**

2.4 - **WARNING: The nut pos. 23 is a mechanical security stop that limits the maximum pressure. Do not remove for any reason.**

3-INSTRUCTIONS FOR CALIBRATION:

The valve is calibrated to the maximum pressure value shown in the table, **IT IS NOT ALLOWED TO EXCEED THIS VALUE**

3.1 - Connect the valve to the water system and follow these steps:

3.2 - Unloose the adjustment knob pos.27 in order to completely release the spring.

3.3 - Open the gun or the water control device and start the system. Make sure that the air contained in it is fully ejected.

3.4 - Keeping the gun or the water control device open, start adjusting the pressure by screwing down the knob pos.27. Alternate the adjusting operations with a few openings and closings of the gun or of the control device. When the desired pressure has been reached, open and close the gun/control device a few times again in order to stabilize the various components (seals, springs etc.). Check the pressure value again and correct if necessary.

3.5 - Lock the nuts pos.37. (ZH284 Only)

In case of doubts, do not hesitate to contact the General Pump Customer Service.



IMPORTANT: During use, never exceed the maximum values of pressure, flow-rate and temperature as stated in this document and/or indicated on the valve.

MAINTENANCE

STANDARD: every 400 working hours, check and lubricate the seals with water resistant grease.

SPECIAL: every 800 working hours, check the wear of the seals and internal parts and, if necessary, replace with original GP parts taking care, during installation, to lubricate with water resistant grease.

The manufacturer is not to be considered responsible for damage as a result from incorrect fitting and maintenance.

TROUBLESHOOTING

PROBLEMS	PROBABLE CAUSES	SOLUTIONS
Frequent valve recycles	<ul style="list-style-type: none"> • Damaged check valve O-ring • Leaking connections • Restricted bypass or too small diameter of the bypass hose 	<ul style="list-style-type: none"> • Replace • Check or renew • Clean or adapt passage diameter
Valve does not reach pressure	<ul style="list-style-type: none"> • Piston O-rings worn out • Debris between seat and shutter • Seat worn out • Nozzle worn out • Incorrect choice of nozzle 	<ul style="list-style-type: none"> • Replace • Clean the seat • Replace • Replace • Fit with smaller nozzle
High pressure peaks at gun closure	<ul style="list-style-type: none"> • There is not a minimum of 5% of total flow discharged in bypass • Excessive flow in bypass • Adjustment with spring totally compressed 	<ul style="list-style-type: none"> • Reset Correctly • Change type of valve or adjust passages • Loosen adjustment screw and eventually fit with smaller nozzle
Valve does not discharge at low pressure at gun closure	<ul style="list-style-type: none"> • Jammed check valve • Debris on check valve 	<ul style="list-style-type: none"> • Clean or replace • Clean

WARNING: High Pressure Systems require a primary pressure regulating device (i.e. regulator, unloader) and a secondary pressure relief device (i.e. pop-off valve, relief valve). Failure to install such relief devices properly could result in personal injury or damage to pump or property. GP does not assume any liability or responsibility for the operation of the user's high pressure system.



WARNING: This product can expose you to chemicals including lead, which is known to the state of California to cause cancer and birth defects or other reproductive harm. For more information, go to www.P65Warnings.ca.gov

