

BRAVE

Edger/Crack Cleaner Assembly Instructions

NOTE: Before assembling the Edger/Crack Cleaner be sure all necessary parts are identified and located in the box. The following components have been shipped with the unit and are necessary to complete the assembly.

Quantity	Part Number	Description
1	BR11584	Upper Engagement Rod
1	BR11862	Lower wheel height adjustment Rod (3/8")
1	BR11863	Upper wheel height adjustment Rod (3/8")
1	BR11866	Handle Assembly
1		Bag - w/loose parts - see contents

Parts Bag Contents:

Quantity	Part Number	Description
4	11815	5/16-18 X 1.00 HHCS
8	11845	.250 USS Flat Washer
4	11905	Nylon Lock Nut
3	11838	Cotter Pin
1	11366	5/16 Washer
2	11155	3/8 (.375) Washer
2	12298	# 10-24 x .6 cap screw
2	11409	# 8 Flat Washer
2	12299	10-24 Nylon Lock Nut
1		Zip Tie (used to secure throttle cable)
1		Engine Manual
1		Operators Manual

Assembly:

1) Install upper handle assembly per figure 1 using the following hardware.

Qty 4 - # 37 - 5/16" x 1" HHCS. Qty 8 - # 38 .250 USS flat washer and Qty 4 - # 23 - 5/16 nylon lock nut (not shown).

Note: Upper handle is placed on the inside of the lower handle arm and the cross over plate (#18) will be placed on the outside. Bolts are inserted through the cross over plate and secured with the appropriate hardware.

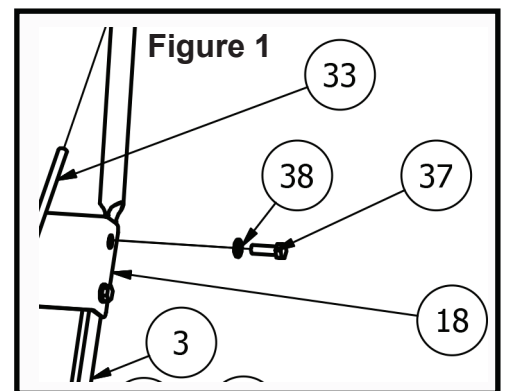

**Any Questions, Comments or Problems
Call Brave Product Support 1-880-350-8739**

WARNING!

BEFORE PERFORMING ANY OF THE FOLLOWING PROCEDURES, BE SURE THE ENGINE IS TURNED OFF, ALL MOVING PARTS HAVE STOPPED AND THE SPARK PLUG HAS BEEN DISCONNECTED.

Belt tension adjustment and replacement:

Note: Belt Tension Adjustments are best achieved by adjusting the engagement spring or by changing the position in the holes on the engagement handle.

Belt tension: The belt can be adjusted in several ways. Un-threading the coupling nut # 36 will lengthen the engagement rod assembly resulting in further movement on the engagement handle. See fig. 7. Adjusting the engagement spring #31 will also change the moving length of the engagement rod see fig. 8. Further more, placing the engagement rod in the alternate holes on the engagement handle will effect belt tension. **NOTE:** Each of these adjustments are used to compensate for belt wear. Under normal operating conditions, the belt tension should be set to a point that insures proper operation of the blade or brush.

Belt Replacement: To replace the belt, remove the belt guard #67 see fig. 9, by removing the two HHCS that secure the guard. This will give you access to the belt for removal and replacement.

With the guard off, the belt can be maneuvered around the drive pulley, the idler pulley and the spindle pulley. Replace the new belt using the reverse of this procedure.

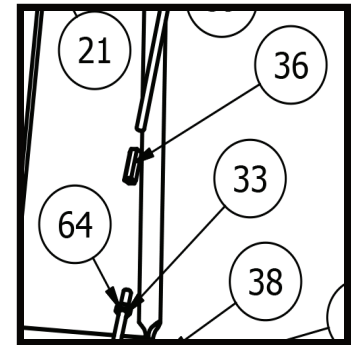

Figure 7

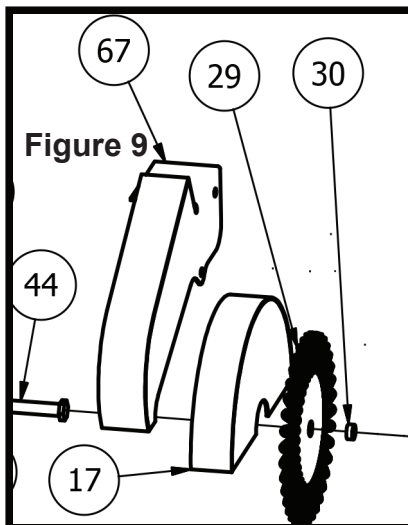

Figure 9

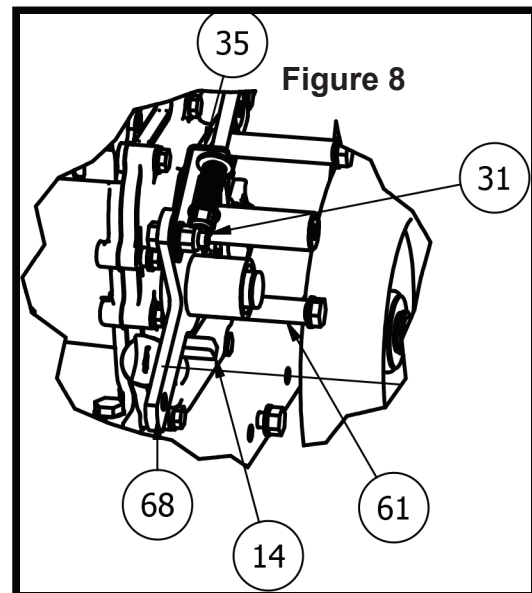
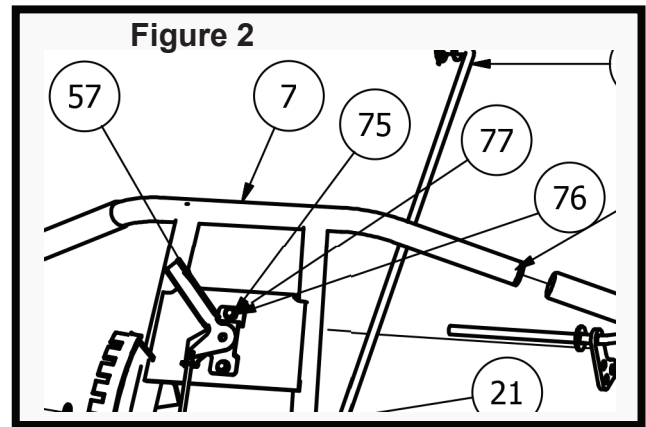

Figure 8

**Any Questions, Comments or Problems
Call Brave Product Support 1-880-350-8739**

2) Install throttle head assembly to the upper handle assembly (figure 2) using Qty 2 - #75 10-24 cap screw, Qty 2 - # 76 flat washer and Qty 2 - # 77 Nylon lock nut.



3) Connect upper engagement rod #32 to lower engagement rod using the attached coupling # 36. Screw the two rods together until completely inserted into the coupling nut. See figure 3 Tighten jam nut to prevent the rods from turning. Note: Orient the bent end of the upper rod so it will be easily inserted into the engagement handle # 19. See figure 4. Insert rod # 32 into the bottom most hole on the engagement handle #19 and secure using a 5/16 washer and cotter pin.

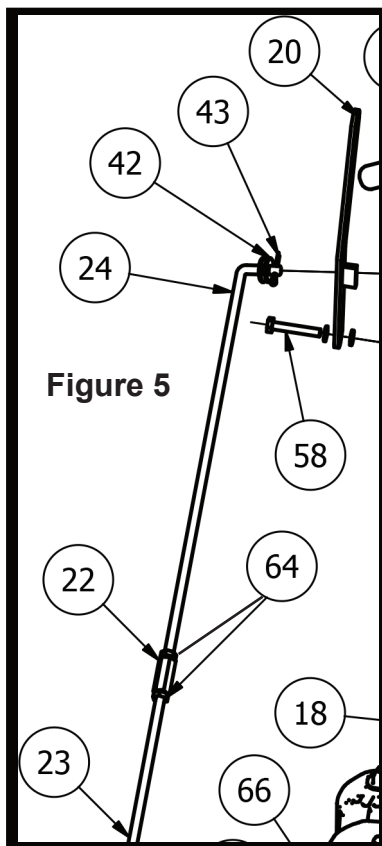
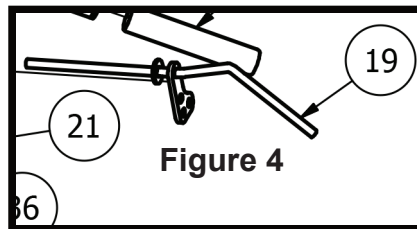
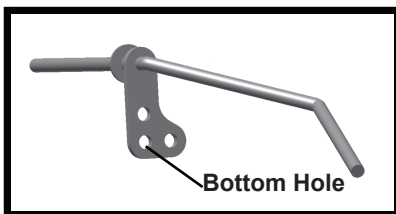
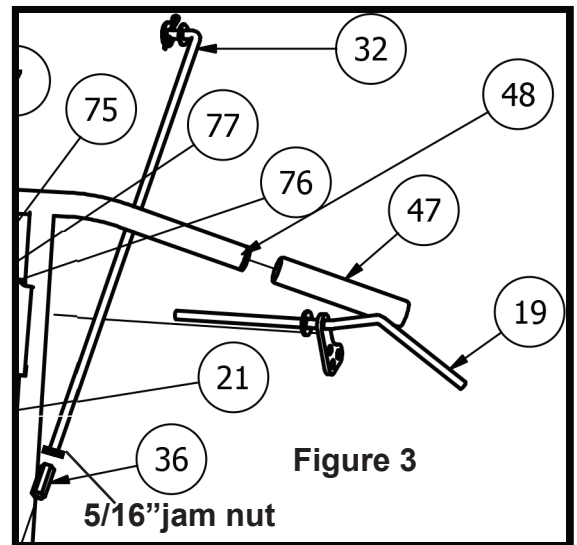

4) Assemble and connect height adjusting rods. Attach Rod # 24 to Rod # 23 using coupling nut # 22 and two jam nuts # 64. See figure 5. Assemble having equal amounts of each rod inserted into the coupling nut, orient the bent rod ends so they are facing the same direction and secure tightly with jam nuts.

Insert the lower rod into the wheel bracket arm # 6 and secure with a 3/8 washer and cotter pin. See figure 6. Now secure the upper rod # 24 into the Adjuster arm # 20 again using a 3/8 washer and cotter pin.

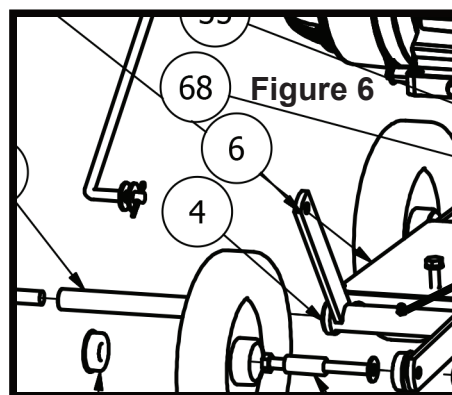

ATTENTION: The front wheel bracket pivot is NOT greased from the factory.

Be sure to grease the bracket before initial use and weekly thereafter.

**Any Questions, Comments or Problems
Call Brave Product Support 1-880-350-8739**

WARNING!

BEFORE PERFORMING ANY OF THE FOLLOWING PROCEDURES, BE SURE THE ENGINE IS TURNED OFF, ALL MOVING PARTS HAVE STOPPED AND THE SPARK PLUG HAS BEEN DISCONNECTED.

Edger Blade / Wire Wheel replacement:

Replacing the blade or wire brush requires removing the locknut that secures the blade / brush. This will allow easy removal of the blade / brush for replacement.

Be sure to re-tighten the nut properly after reassembling the components. (Torque Nut to 25 ft /lbs) This procedure is also used when converting an edger to a crack cleaner and or a crack cleaner to an edger.

See figure 10 for details.

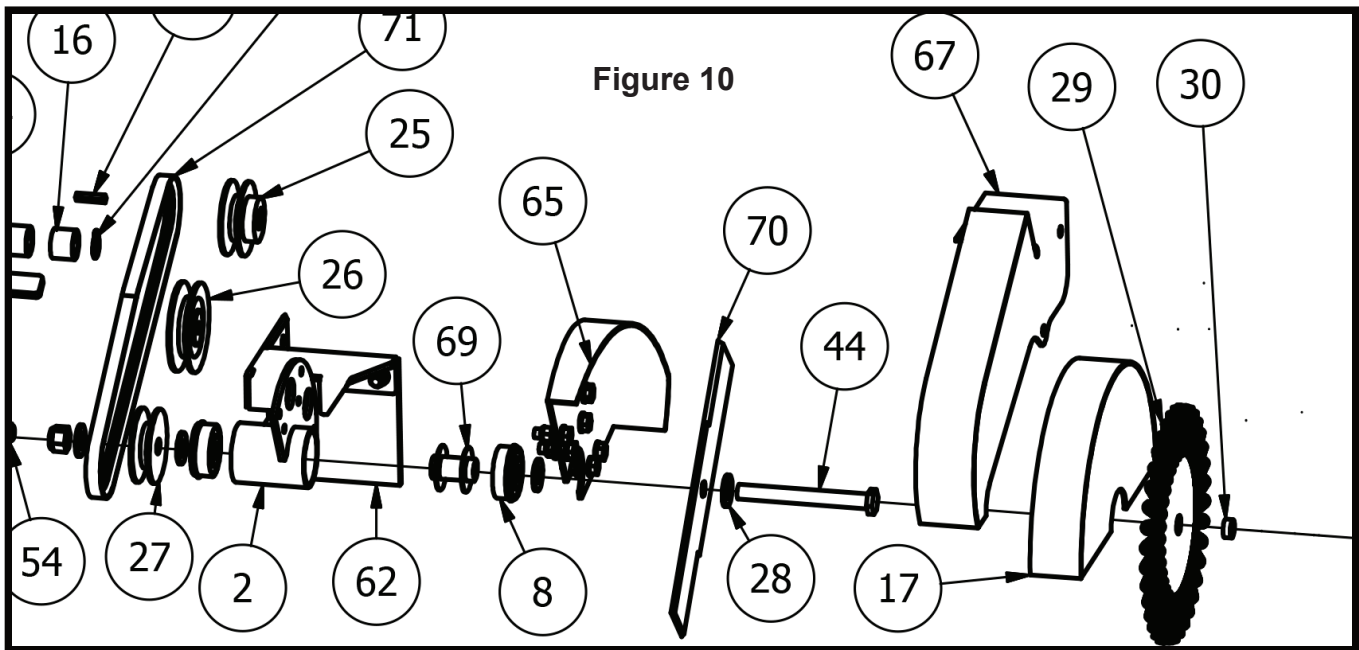

NOTE: On the height adjustment handle, there are multiple notches which determine the cutting height of the Blade or Brush. The upper 2 notches are not used on some models. It will be difficult to place the adjustment handle in this position. Do Not Force.

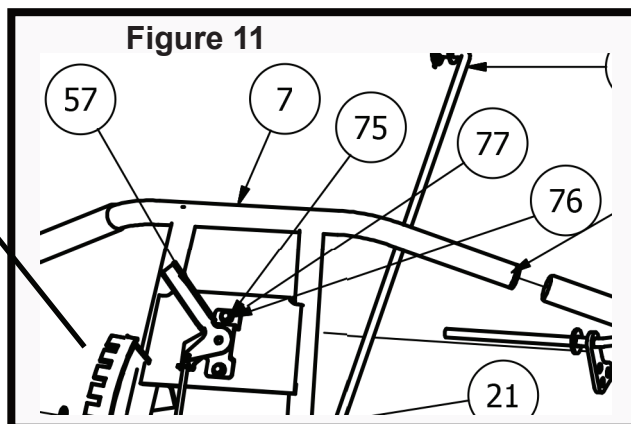

BRAVE

*Any Questions, Comments or Problems
Call Brave Product Support 1-880-350-8739*