

OWNERS MANUAL



Multiple Application Concrete Saw

MODEL:

GC55 and GC25E

FORM <<GC55-GC25E rev 7/2017



WARRANTY

Norton warrants all products manufactured by it against defects in workmanship or materials for a period of one (1) year from the date of shipment to the customer.

The responsibility of Norton under this warranty is limited to replacement or repair of defective parts at Norton's Stephenville, Texas factory, or at a point designated by it, of such part as shall appear to us upon inspection at such point, to have been defective in material or workmanship, with expense for transportation borne by the customer.

In no event shall Norton be liable for consequential or incidental damages arising out of the failure of any product to operate properly.

Integral units such as **gasoline engines, electric motors, batteries, tires, transmissions, etc.**, are excluded from this warranty and are subject to the prime manufacturer's warranty.

This warranty is in lieu of all other warranties, expressed or implied, and all such other warranties are hereby disclaimed.

Important: Before placing equipment in operation, record the following information.

MODEL: _____ **SERIAL NO.** _____

PURCHASE FROM: _____

ADDRESS: _____

CITY _____ **STATE** _____ **ZIP** _____

TELEPHONE NO. _____

Before using this equipment, make sure that person using it read and understand the instructions in this owner's manual.

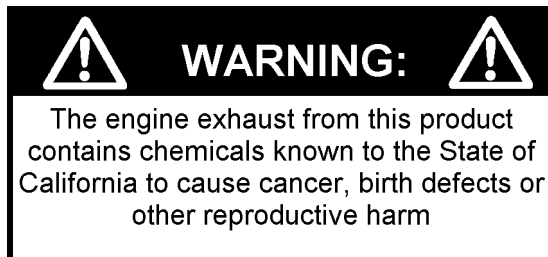

Table Of Contents

CONTENTS	PAGE
I. Preparation	
A. Safety Precautions	4-6
B. Assembly	7
C. GC55 and GC25E Series Concrete Saw Specifications	8-9
D. Engine GC55 Models	10
Pointer Alignment	10
E. Electrical Connections GC25E	11-12
Generator	11
Wiring Diagram GC25E	12
Pointer Alignment	10
II. Operation	
A. Installing The Blade	12-13
B. Starting The Engine GC55	13
C. Operating The Saw	13-15
D. Cutting Technique	15
E. Green Concrete Cutting	15-18
III. Maintenance	
A. Engine	18-20
B. Bearings	20
C. V-Belts	20-21
D. Depth Control	21
E. Dust Removal System Adjustment	21-22
IV. Parts List Section	
A. Ordering Information	23
B. Parts Drawing / Service Parts List	24-38
Blade Guard Assembly GC55 and GC25E	24
Cutting Head Assembly GC55 and GC25E	25
Blade Shaft Assembly GC55 and GC25E	26
Depth Control Assembly GC55 and GC25E	27
Engine Assembly GC55 Only	28
Motor Assembly GC25E Only	29
Frame Assembly GC55 Only	30
Frame Assembly GC25E Only	31
Front Pointer Assembly GC55 and GC25E	32
Main Assembly GC55 Only	33-35
Main Assembly GC25E	36-38



Read Owners Manual Before Use



Safety Alert Symbol: Information Following This Symbol Is Very Important.

Use Only Norton Diamond Blades

I. PREPARATION

A. Safety Precautions

Important! The following safety precautions must always be observed.

Hazard Symbols



Fuel (gasoline) is extremely flammable and its vapors can explode if ignited. Store gasoline only in approved containers, in well-ventilated, unoccupied approved areas, and away from sparks or flames. Do not fill the fuel tank while the engine is hot or running. Do not start the engine near spilled fuel. Never use the fuel as a cleaning agent.



Engine components can get extremely hot from operation. To prevent burns, do not touch the engine or related parts while the engine is running or immediately after it is turned off. Never operate the engine with any heat shields or guards removed.



Keep all guards in place when operating any piece of equipment



Keep hands, feet, hair, and clothing away from all rotating parts



Lethal Exhaust Gas use only in well ventilated areas. Engine exhaust gases contain poisonous carbon monoxide, which is odorless, colorless, and can cause death if inhaled. Avoid inhaling exhaust fumes, and never run the engine in a closed building or confined area.



Never tamper with the governor components of settings to increase the maximum speed. Severe personal injury and damage to the engine or equipment can result if operated at speed above maximum. Always obey the maximum speed rating of blade.



DO NOT LIFT THE SAW BY THE HANDLE BARS

WARNING

Dust and Silica Warning

Grinding/cutting/drilling of masonry, concrete, metal and other materials can generate dust, mists and fumes containing chemicals known to cause serious or fatal injury or illness, such as respiratory disease, cancer, birth defects or other reproductive harm. If you are unfamiliar with the risks associated with the particular process and/or material being cut or the composition of the tool being used, review the material safety data sheet and/or consult your employer, the material manufacturer/supplier, governmental agencies such as OSHA and NIOSH and other sources on hazardous materials and make certain to comply with all product warnings and instructions for the safe and effective use of the material being cut. California and some other authorities, for instance, have published lists of substances known to cause cancer, reproductive toxicity, or other harmful effects.

Control dust, mist and fumes at the source where possible. In this regard use good work practices and follow the recommendations of the manufacturer/supplier, OSHA/NIOSH, and occupational and trade associations. Water should be used for dust suppression when wet cutting is feasible. When the hazards from inhalation of dust, mists and fumes cannot be eliminated through engineering controls such as vacuum and/or water mist, the operator and any bystanders should always wear a respirator approved by NIOSH/MSHA for the material being cut.

Use Approved:



Eye Protection



Hearing Protection



Respiratory Protection



Head Protection

1. Before mounting any blade on the saw, the blade should be inspected for any damage which might have occurred during shipment, handling or previous use.
2. The blade collars and arbors should be cleaned and examined for damage before mounting the blade.
3. The blade must be properly fitted over the arbor with the drive pin on the outside collar projecting through the drive pin hole on the blade and inside collar.
4. The blade shaft nut, which is a left-hand thread nut, must be tightened securely against the outside blade shaft collar.
5. The blade must be operated within the specified maximum operating speed listed on the blade.
6. The blade guard must be in place with the nose guard down and locked when the saw is running.
7. The operator should wear safety glasses and any other appropriate safety equipment.
8. When starting the saw, the operator should stand away and to the side of the blade.
9. If for any reason the saw should stall in the cut, raise the blade out of the cut. Check the outside blade shaft collar and nut for tightness. Inspect the blade for damage before restarting the saw. Use caution when resuming a cut. Be certain that the blade is in alignment with the previous cut.
10. During cutting operations, do not exert excess side pressure on the handles as a method of steering. Do not force the blade into the cut by lowering the blade too fast or by pushing the saw too fast.



You Are Responsible For Your Safety!!!

I. PREPARATION

B. Assembly

The GC55 and GC25E compact concrete saws are shipped completely assembled and ready for use except for diamond blade, gasoline, oil, and Handle Bar position for the GC55 and diamond blade, electrical extension cord, and power supply for the GC25E. Inspect the saw for shipping damage. If any damage is found, contact the shipper immediately and file a freight claim. Saint-Gobain Abrasives, Inc. is not responsible for any freight-related damages.

Adjust the Handle Bars Position:

1. Remove the GC55/GC25E from the box.
2. Remove the Quick Release Pin P/N: 241055 out of its retaining hole
3. Loosen the Black Knob P/N: 241054.
4. Rotate the Handle Bar from the lowered storage position to the desired position.
5. Align the hole in the Handle Bar with the holes in the frame.
6. Attach the Quick Release Pin P/N: 241055 by pushing it through the hole in the Frame and then the hole in the Handle Bar. Make sure that the Quick Release Pin passes all the way through both sides of the Frame.
7. Tighten the Black Knob P/N: 241054.

Read and understand the remaining sections of this Owner's Manual. NOTE: Do not install the blade until it is time to use the saw. ANSI regulations prohibit the transportation of any concrete saw with the blade installed.

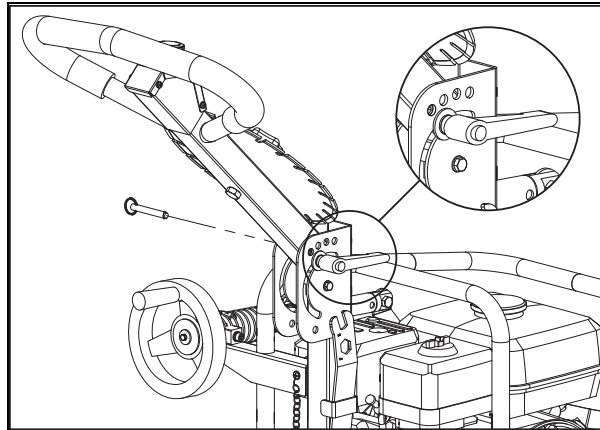

Part #	Description	QTY
241054	SCR 5/16-18 UNC X 2-1/2" CARRIAGE BOLT	1
241055	PIN QUICKRELEASE 5/16" X 2" GRIP LENGTH	1
241054	KNOB M8 X 1.25 ADJUSTABLE	1
232110	WASHER M8 DIN125 FLAT	1
241055	WASHER 3/8 WAVE	1

C. GC55 and GC25E Series Concrete Saw Specifications

Dimensions/Weight	GC55	GC25E
Length (Working)	42-23/32" (1,090mm)	42-23/32" (1,090mm)
Length (Transport)	32" (813mm)	32" (813mm)
Width	18-1/8" (460mm)	18-1/8" (460mm)
Height	42-23/32" (1,090mm)	42-23/32" (1,090mm)
Frame Width	18-1/8" (460mm)	18-1/8" (460mm)
Pointer Length	8-7/32" (209mm)	8-7/32" (209mm)
Blade To Wall	7-1/2" (190mm)	7-1/2" (190mm)
Wheel Base Length	19" (483mm)	19" (483mm)
Blade Shaft Maximum Height	9-41/64" (245mm)	9-41/64" (245mm)
Weight Created	135 lbs (61 kg)	155 lbs (71 kg)
Weight Uncreated	115 lbs (52 kg)	135 lbs (61 kg)
Power Source		
Engine/Motor Mfg.	Honda	Gangfon Motor
Spec No.	GX160K1QXC	Totally Enclosed Air Cooled Thermal Protection
Power Source	Single Cylinder 4 Cycle Gasoline	Electric
Maximum Horse Power*	5.5 HP (4.1 kW)	2-1/2 HP
Net Horse Power	4.5 HP (3.4 kW)	2-1/2 HP
Max Torque	7.6 lb-ft (10.3 Nm) @ 2500 rpm	-NA-
Power Source RPM	3,600 RPM	3450 RPM
Model	GX160	Dual Voltage
Cooling System	Forced Air	Forced Air
Oil Capacity	0.6 liter (0.63 US qt)	-NA-
Fuel Capacity	3.1 liter (3.28 US qt)	-NA-
Fuel Type	Unleaded Gasoline (86 pump octane)	-NA-
Low Oil Sensor	Yes	-NA-
Air Filtration	Four Stage Cyclone	-NA-
Voltage	-NA-	115-230 volts
Cycles/Current/Phase	-NA-	60Hz/AC/1
Full Load Amps (115/230 volts)	-NA-	15/7.5 Amps
Starting Amps (115/230 volts) ²	-NA-	45/22.5 Amps
Displacement	9.9 in ³ (0.16 l)	-NA-
Bore x Stroke	2.7" (68mm) x 1.8" (45mm)	-NA-
Starter	Manual	Capacitor
Characteristics		
Max Blade	Ø10" (254mm)	Ø10" (254mm)
Depth of Cut 10" (254 mm)	3.5" (88mm)	3.5" (88mm)
8" (203 mm)	2.5" (63mm)	2.5" (63mm)
Arbor Bore	5/8"	5/8"
Blade Shaft Flange Diameter	3-5/64" (78mm)	3-5/64" (78mm)
Blade Shaft Speed	2905 rpm	2905 rpm
Depth Control	Hand Wheel With Screw Feed	Hand Wheel With Screw Feed
Depth Lock	Standard	Standard
Depth Gauge	Standard	Standard
Number Of V-Belts	1	1
Blade Guard Type	Screwed On, All Steel Construction	Screwed On, All Steel Construction
Cutting Side	Center	Center
Lifting Bale	Built In	Built In
Handle Bars	Adjustable, Stays Level At All Times	Adjustable, Stays Level At All Times
Wheels	Non-marking	Non-marking
Wheel Size Front and Rear	3-3/8"x2-3/4"x25/32" (85x70x20mm)	3-3/8"x2-3/4"x25/32" (85x70x20mm)
Sound pressure ³	88 db (A)	-NA-
Sound power ³	105 db (A)	-NA-

1) Net Horsepower Rating provided by engine the manufacturer measured in accordance to SAE j1349 @ 3,600 RPM. The engine may vary from this value. Actual horsepower on the machine will vary due to operating speed of engine, belt tension, environmental conditions, machine maintenance, and other variables.

2) Starting Amps are instantaneous – for best results use with a 30Amp circuit.

3) The sound measures have been made following pr EN 12638, Annex A; - 2 "Floor sawing, grooving and milling machines – Safety "

The GC55 and GC25E concrete saws were designed from the ground up to be a High Performance Multiple Application saw. The GC55 and GC25E are capable of cutting Green Concrete (Early Entry), Cured Concrete, Asphalt, and Decorative Concrete. Being able to cut more than just green gives the GC55 and GC25E many advantages over the competitor's machines such as a lower investment for our customer.

Used For Cutting Multiple Applications:
Green Concrete (Early Entry)
Decorative Concrete
Cured Concrete
Asphalt

Features that make the GC55 and GC25E a High Performance Multiple Applications Saw:

- Blade in center line of saw helps to reduce tearing of concrete when cutting green concrete. The center line blade also helps the GC55 and GC25E to roll straight while cutting due to the blade being parallel to the blade.
- Reinforced all steel frame reduces bending, flexing, and vibrations which can damaged the concrete. The reinforced all steel frame is also stronger than the competitive models
- Soft Silicone Rubber wheels that are based off of a Norton Patient to absorb vibrations that can create spalling and machine movement. The wheels also feature a concave profile that helps the machine to roll over small objects with out upsetting the blade.
- 10" maximum blade capacity with standard 5/8" arbor. The GC55 and GC25E can be used with 7" to 10" diameter Norton blades.
- Hand Wheel with Depth Adjustment Screw & Depth allows precise depth adjustments up to 3-1/2" deep when used with a 10" blade.
- Fully adjustable non-scratching dust removal system helps stabilize the GC55 and GC25E by pushing debris way from wheels and undercarriage of the machine.
- Front and rear pointers for precise alignment.
- Handle Bar and Pointer folds up for compact easy transport.
- Light in weight, the GC55 weighs only 115 lbs.
- The GC55 and GC25E are very simple machines to operate.
- The GC55 and GC25E are designed for cutting multiple applications: Green Concrete (Early Entry), Cured Concrete, Asphalt, and Decorative Concrete.
- Includes a free 10" GMAX blade. The GMAX blade is specifically designed with the following features for improved Green Concrete cutting:
 - Anchor Slot Core Technology Reduces Chip Causing Vibrations.
 - Thicker Core Resist Flexing and Bending For Improved Cut Quality.
 - Optimize Bond And Diamond For Fast Green Concrete And Aggregate Cutting.

D. Engine GC55 Models

Prior to attempting to operate the engine, read the information contained in the engine owner's manual. An engine owner's manual is supplied with every gasoline powered concrete saw.

1. **Check Oil:** Add oil if low. Refer to the engine owner's manual for the recommended SAE viscosity grades. Capacity of oil is 0.6 liter (0.63 US qt.)
2. **Check Fuel:** Fill if low. Use only unleaded gasoline with a pump sticker octane rating of 86 or higher is recommended. **Never use an oil and gasoline mixture!**
3. **Air Cleaner:** Never run the engine without the air cleaner! Rapid engine wear will result from contaminants being drawn through the carburetor and into the engine.
4. **Engine Starting:** Refer to the engine owner's manual for proper engine starting procedure.

Pointer Alignment

1. Use a straight edge, and carefully mark a line 12 feet long on a smooth level surface.
2. Place the saw blade on the marked line, move the saw to the center of the marked line and then lower the blade until it is about 1/16" above the marked line.
3. Measure from each end of the saw frame to insure that the frame is parallel to the marked line. Adjust the saw as needed.
4. With the blade centered on the marked line and the saw frame parallel to the marked line, lower the front pointer.
5. Adjust the nylon nuts until the pointer is aligned with the marked line.

E. Electrical Connections GC25E



Important-Before connecting the motor leads to the power supply be sure that the voltage, cycles and phase shown on the nameplate of the motor correspond to the available power supply. Voltage Selection for the GC25E 3 HP motor is single phase saw motor which has a dual voltage capability. Either a 115-volt or 230 volt power supply can be used. To change voltage simply move the voltage change switch located on the front of the motor to the required voltage, no rewiring is required. Wherever possible, use 230-volt power supply for best operation.



Failure to run the motor on the proper voltage will damage the motor and is not covered under warranty. Improperly wired motors are not covered under warranty.

The GC25E models are wired for 115 Volt from the factory!!!

Power Connections

Connect the power supply to the pigtail leads of the switch. Direct wiring connection is preferred, but an extension cord with an electrical plug with 30-amp minimum capacity may be used. A 30-amp circuit breaker is recommended. Connecting wires should be as short as possible and in one piece. In no case should the connecting wires be longer than shown in the following table for use with the GC25E Single-phase motors:

Wire Gauge	Length Of Wire	
	115 Volt	230 Volt
Number 12	25 ft (7.6 m)	100 ft (30.5 m)
Number 10	50 ft (15.2 m)	150 ft (45.7 m)
Number 08	75 ft (22.9 m)	175 ft (53.3 m)

Caution-When wires that are too small gauge or too long are used, loss of power, over heating, or possible damage to the motor will result. Damage or failure of motors due to incorrect power supply cord lengths are not covered under any warranty.



Always use the proper wiring connectors that are UL/CSA approved to attach the motor to the electrical supply. Any wiring hook ups should be made by qualified personal and made to National Electrical Code and to any Local Codes.

Generators:

If a generator must be used, it must be of 8kW or larger. The generator must have a 30A circuit and capable of providing a minimum of 8kW at the required voltage. Under size generators will cause motor damage and is not covered under warranty.

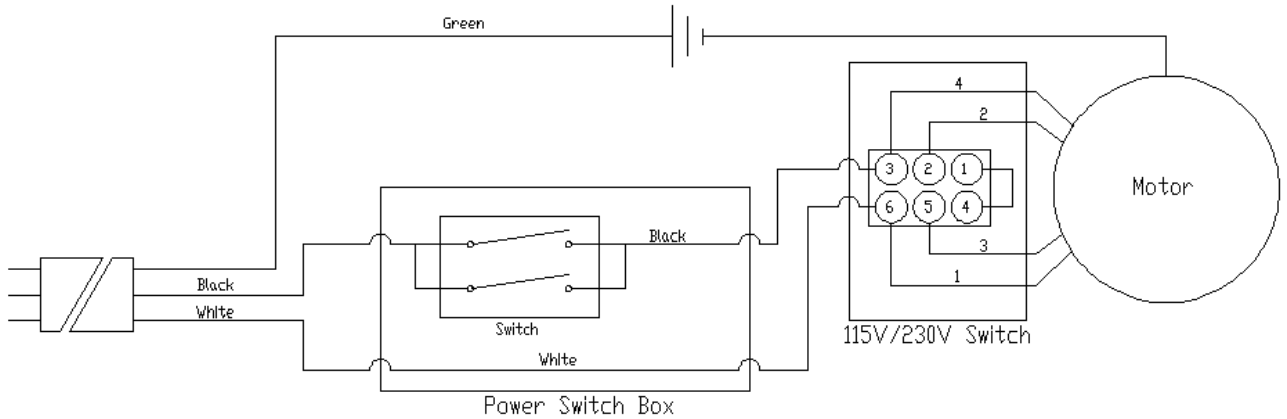

Wiring Diagram GC25E Only

Thermal Reset:

If the thermal reset engages this is a sign that the motor is over heating. Continued over heating will damage the motor. The thermal reset will reset itself once the motor is cooled. Do not force the thermal reset as it will damage the reset and motor. The causes of the thermal reset activating are:

1. Too Long or Too Thin of Extension Cord (Low Voltage). Use the correct length and gauge of Extension Cord.
2. Low Voltage Power Supply. Use a power supply with the correct voltage.
3. Incorrect Blade of Application. Contact Norton Clipper's customer service or your local sales person for the correct blade specification for your cutting application.
4. Overloading Machine. At a shallower depth. Make multiple passes (Step Cutting) at no more than 1-1/2" deep. Cut at a slower forward speed.



Damage or failure of a motor due to continued over heating as the result of incorrect extension cord length/size, incorrect power supply, incorrect application, and continued overloading is not covered under warranty.

II. OPERATION

A. Installing the Blade

1. Disconnect the spark plug (GC55 Models Only)
2. Raise the Blade Guard to its highest position.
3. Open the blade nut access door. Remove the blade shaft nut (Turn clockwise) and remove the outside collar and raise the Blade Guard.

4. Clean off any foreign particles on the clamping surfaces of both collars and on the mounting surface of the blade.
4. Position the blade beneath the cutting head and slide the blade into the blade guard (slide the blade under the blade guard at an angle will simplify the installation process). Be careful not to hit the blade shaft with the blade.
5. Locate the blade shaft then slide the blade bore hole onto the blade shaft.



Use only Norton Diamond Blades. This machine was not designed for the use with abrasive blades. For the best performance when cutting green concrete use the Norton GMAX series blade.

6. Slide the outside blade shaft collar onto the blade shaft.
7. Tighten the blade shaft nut (Turn counter-clockwise) securely against the outside collar. Close the blade nut access door.
8. Reconnect the spark plug (GC55 models only).

Use Only Norton Diamond Blades

B. Starting the Engine GC55

1. Refer to the engine owner's manual for the proper starting procedures.
2. Always cut with engine rpm in the full throttle setting.

C. Operating the Saw

1. For blade installation instructions see section ***II. Operation sub heading A. Installing the Blade.*** For the engine starting instructions (GC55), see the ***Engine manual*** and follow the instructions located in section ***II. Operation sub heading B. Starting the Engine*** and for Electrical Connections (GC25E) see section ***E. Electrical Connections GC25E***
2. Check the Engine Oil level (GC55 only).
3. Raise the saw to the full upright position. Do not let the blade come in contact with the ground.
4. Maneuver the saw to the desired starting point.
5. To start the machine

- a. GC55: Follow the instructions for starting the engine found in the Engine manual.
 - i. Verify that the emergency stop switch is in the up position
 - ii. Turn Engine On/Off Switch to the on position
 - iii. Turn the Fuel Control to the On position
 - iv. Engage Choke as necessary
 - v. Pull start rope. If the engine does not start within 3-5 pulls of the start rope, refer to the engine owner's manual for more information.
- b. GC25E: For Electrical Connections, Extension Cord Set Information, and Generator Information see section ***E. Electrical Connections GC25E***
 - i. Verify that the motor voltage change switch is set to the same voltage as the circuit.
 - ii. Verify that the circuit has a 30 Amp breaker installed.
 - iii. Verify that the extension cords are the correct gauge, length, and are properly grounded.
 - iv. Verify that the GC25E power switch is in the off position.
 - v. connect the extension cord set to the machine and power supply. Follow all local and national electrical code. If unsure of how to connect the extension cord set or of the electrical circuit have a qualified Electrician make all electrical connections.
 - vi. Move the start switch to the On position and the motor should start. If the motor does not start have a qualified Electrician inspect all electrical connections and the power supply

6. For the GC55 be sure the engine is running at full throttle!!!
7. Slowly lower the blade by rotating the hand wheel clockwise until the desired depth of cut is reached. Use a reasonable rate of feed. Do not force the blade into the cut!! If the engine starts to die slow down the rate of feed! If the machine tries to climb out of the cut, slow down the rate of feed!
8. When the end of the cut is reached, slowly raise the blade out of the cut by rotating the Hand Wheel counter-clockwise until the blade is at least one (1) inch above the ground.
9. Only move the saw in reverse with the blade in the raised position.
10. When moving the saw to a new location, be sure the blade is not touching the ground. Always pay close attention to where you are moving and where the blade is at all times.

D. Cutting Technique

Lower the blade into the concrete to the required depth by turning the hand wheel clockwise.

Push the saw steadily forward using the front pointer as a guide. Exert enough forward pressure so that the engine begins to labor, but does not slow down. If the saw begins to stall, reduce the forward movement until full rpm is restored to the blade. If the saw stalls, raise the blade out of the cut before restarting. Avoid excessive side pressure or twisting of the blade in the cut.

When cutting for best performance do not cut at more than 1-1/2" deep per pass. Making multiple shallow passes will increase blade life, speed of cut, and decrease engine/motor loads.

Additional Guide Lines For Sawing:

- Understand and follow all of the instructions in this owner's manual.
- In critically hard aggregate, be careful not to feed too quickly as it may stall the saw or ruin the cut.
- If the saw stalls in the cut, immediately stop the forward speed and raise the blade out of the cut. If this is not done the belts can fail or the blade may be damaged.
- Go slowly with a new blade until it opens up, that is, until the diamonds can be seen and felt.

E. Green Concrete Cutting

The new Norton Clipper GC55 and GC25E are much more than a green concrete saw or as it is some times called an early entry saw. The GC55 and GC25E were designed from the ground up to be a High Performance Multiple Application saw. The GC55 and GC2E models are capable of cutting Green Concrete (Early Entry), Cured Concrete, Asphalt, and Decorative Concrete. Being able to cut more than just green gives the GC55 and GC25E many advantages over the competitor's machines such as a lower investment for our customer.

Green Concrete Cutting Important Considerations

Green concrete is concrete that is still in a plastic state that is the concrete still has a lot of moisture in it, in other words it is not fully cured or dry. As the concrete starts to hydrate (Dry or Cure), the concrete will change slightly in volume. Concrete normally shrinks about 1/16" for each 10 feet during the hydration process. This

change in size creates internal stress in the concrete which will develop into cracks. Joints also known as Crack Control Joints and or Expansion Joints are normally cut into the concrete in order to relieve the internal stress and to create an area where a controlled crack will occur. With the joint in place the concrete will normally crack in a straight line underneath the joint. The idea behind cutting the green concrete is that the sooner the stress relieving joints are made the better control over the random cracking will be obtained. For most green cutting the depth of cut is made at 25% of the overall thickness of the concrete, for example if the concrete is 6" thick, the cutting depth would be set to 1-1/2" deep. One important fact to remember is that Green Concrete is any concrete that has set up but not hardened. For concrete to become fully hardened it may take 5 to 7 days.

There are a few factors that affect green concrete cutting quality, and time that the cutting can begin. The following list is extremely important to follow and to understand in order to create a good quality cut with no spalling or chipping of the cut line.

1. The concrete must set up long enough to hold the aggregate in place. If not the aggregate will tumble and move when the Diamond Blade contacts it, causing internal damage to the concrete and possible tearing or spalling of the concrete surface. The aggregate along with the concrete must be cut for proper crack control. Without proper set up the aggregate will roll or move within the concrete creating voids and spalling or chipping of the cut line will occur. Concrete set up is the MOST important issue to obtaining a quality cut line when green concrete cutting. Factors that affect the concrete set up are:
 - a) Concrete Mixture – PSI, concrete type, sand type and amount, and other materials.
 - b) Water to Cement Ratio – more water the longer the set up
 - c) Aggregate Size and Type
 - d) Concrete Additives – some speed up while others slow down the set up time.
 - e) Environmental Factors – Sun, Wind, Rain, Temperature
 - f) Concrete Temperature – cooler the concrete the longer the set up time.
2. Flat surface. Flat surfaces help to insure that the blade is perpendicular to the concrete which reduces the chances of damaging the concrete surface. When the blade meets the concrete surface at a 90° angle (perpendicular) less side drag is created on the blade. When the blade is not perpendicular side drag is create that will cause the concrete to chip or spall.
3. Blade that is designed for green concrete cutting. The GMAX blade has some unique features that make it an outstanding blade for green concrete cutting such as:

- a) Anchor Slot Core Technology that reduces vibrations in the blade. Excessive vibrations will cause the blade to flutter or bend from side to side which will damage the concrete surface and cause the blade to wear out prematurely.
- b) Thicker core that resist flexing and bending. Thin core blades bend due to excessive pressure during cutting and from over heating. When blade bends and flexes the concrete and blade will be damaged.
- c) Optimized bond and diamond for fast green concrete cutting. The improper bond will not cut green concrete properly.

When to Start Green Concrete Cutting

Timing is the most important aspect of cutting green concrete. The time that the operator can start cutting will vary depending on the key factors listed above. For example if the concrete has a high water to cement ratio or the day is cooler then more time is required for the concrete to properly set up and hold the aggregate in place. Typically we are finding that starting around 5 to 6 hours after finishing good results can be obtain. We find in our testing that at 16 hours in gives the best results. These times to start are assuming that the concrete has set up long enough to hold the aggregate in place.

Green Concrete Cutting Trouble Shooting

Spalling or Chipping On Both Sides of Cut:

1. **Wait** at least 1 to 2 more hours before cutting. The very good cut appearance is achieved at 5 to 6 hours after finishing complete. The best cut appearance occurs when the concrete has set up enough for the aggregate to be held in place which may take up to 16 hours. The actual time to begin cutting will depend on many factors such as: concrete mixture (PSI, concrete type, sand type and amount, and other materials, water to cement ratio – more water the longer the set up), aggregate size and type, concrete additives – some speed up while others slow down the set up time, environmental factors (Sun, wind, rain, temperature), concrete temperature (Cooler the concrete the longer the set up time).
2. **Check** blade specification. The improper blade specification will create additional spalling or chipping of the concrete. For best results use a Norton GMAX series Blade. The Norton GMAX series have unique features to improve the green concrete cut quality and the overall efficiency of the blade while cutting green concrete. The GMAX blade provided with the GC55 was designed exclusively for use on this product to provide maximum performance and a precision cut appearance!
3. **Check** blade for wear. As the blade loses width the cut appearance will get worse. Blades with segments that look like a knife blade need to be replaced immediately as a blade in this condition will create a poor quality cut line.

4. **Check** concrete surface for flatness.
5. **Replace** the blade with a new blade of the same specification.
6. **Replace** blade with the correct specification.

Cut Appearance Previously Fine But Now Constantly Spalling or Chipping On One Side Of The Cut:

1. **Check** for warped blade. A warped or out of tension blade will create a cut that has spalling and chipping. Replace blade if necessary.
2. **Check** the tracking on saw.
3. **Check** that the machine is being pushed in a straight line.

Thin Shell Chipping of Concrete:

1. **Wait** 1 to 2 hours for the concrete cure depth to increase. Shell chipping is caused when the top layer of concrete is curing at a faster rate than the concrete below. The concrete needs to cure to a deeper depth in order to prevent the shell chipping.

III. MAINTENANCE

A. Engine GC55

Follow the below schedule for engine maintenance. NOTE: Check the Honda Engine manual that came with the engine for any changes to the maintenance schedule. If the charts have any differences, follow the chart in the Honda Engine Manual. The Norton Clipper does not warranty the engine. If any warranty or service of the engine is required contact your nearest Honda service center, or from the Internet: <http://www.honda-engines.com/home.htm>

Honda engine (Refer to owner's manual for complete maintenance.)

MAINTENANCE SCHEDULE

REGULAR SERVICE PERIOD Perform at every indicated operating hour interval.		EACH USE	FIRST 20HRS	EVERY 50HRS	EVERY 100HRS	EVERY 300HRS	Refer to page	
Engine oil	Check level	○					3-2	
	Change		○		○			
Reduction gear oil	Check level	○					3-2	
	Change		○			○		
Air cleaner	Check	○					3-3	
	Clean			○ (1)				
Fuel strainer cup	Clean				○		3-7	
Spark plug	Check-Clean				○		3-6	
Valve clearance	Check-Adjust					○	3-5	
Combustion chamber and valves	Clean-Lap					○	9-3,4	
Fuel line	Check (Replace if necessary)	Every 2 years						3-8

NOTE: (1) Service more frequently when used in dusty areas.

Check the engine oil level before each use when the engine is cool and the engine is level. Add oil if the level is low. The oil level should be within the operating range (See the engine owner's manual for details).

Only use a high-detergent, premium quality motor oil certified to meet or exceed U.S. automobile manufacturer's requirements for Service Classification SG, SF/CC, CD. Motor oils will show the classification on the container. A SAE viscosity of 10W-30 is recommend by Honda for general, all temperature use. Please consult the below chart or contact your local Honda service center for the proper viscosity for your temperature range.

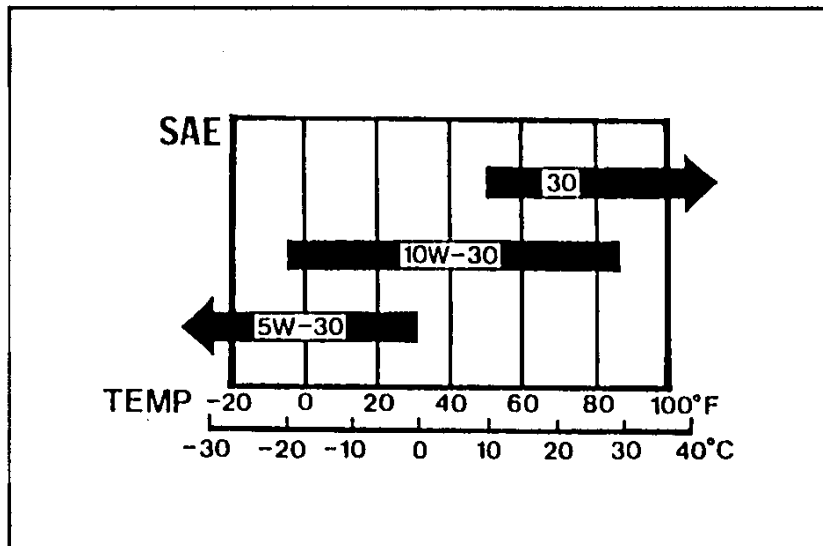

Always refer to the engine manual for more detailed information on checking the oil, changing oil, and oil capacity, air filter changes, and fuel type to use.

Use only Honda air filters. Do not clean the air filter with gasoline or other flammable solvents. A fire or explosion could result. To clean, follow the instructions found in the Honda engine manual.

Dry Cutting Engine Maintenance

- When operating the engine in dry cutting or dusty environments the following is required:
- Engine oil changed more often.
- Every 50 hours (or more often if conditions require) clean all of the engine cooling fins.
- Every 25 hours (or more often if conditions require) clean the engine pre-cleaner.
- Every 100 hours (or more often if conditions require) replace the air filter. If the engine is equipped with a reusable air cleaner, clean and re-oil it.
- Check and clean the air filter after each use. Replace as needed.

B. Bearings

The GC55 and GC25E are equipped with permanently sealed blade shaft and wheel bearings that will never need any lubrication. These types of bearings are designed for long life and minimum maintenance. If any problem occurs with the blade shaft, or wheel bearings replace the bearing.

The only the Raise Screw and Cutting Head pivot point will need periodic re-lubrication. Both of these points require just a squirt of a good quality NLGI #2, aluminum complex type grease is recommended one time a month. Check the function of the Hand Wheel and Cutting Head before each use. Lubricate the Raise Screw and Cutting Head pivot point once a month or when the it becomes hard to turn the Hand Wheel.

C. V-Belts

Warning: Never make adjustments to belts or pulleys while engine is running!

1. The best tension for a belt drive is the lowest tension at which the belts will not slip under full load.
2. Simply take up the drive until the belts are snug in the grooves. Run the drive for about 15 minutes to "seat" the belts. Then impose the peak load. If the belts slip, tighten them until they no longer slip at peak load.
3. **Remember, too much tension shortens belt and bearing life!**
4. Check the belt tension frequently during the first day of operation. Check the belt tension periodically thereafter and make any necessary adjustments.

5. The two most common causes of misalignment are shown in the Figure 1 and Figure 2 to the right.

- a). The engine drive shaft and the blade shaft are not parallel.
- b). The pulleys are not located properly on the shafts.

6. To check alignment, all you need is a steel straight edge.

7. Line up the straight edge along the outside face of both pulleys as shown in the drawing.

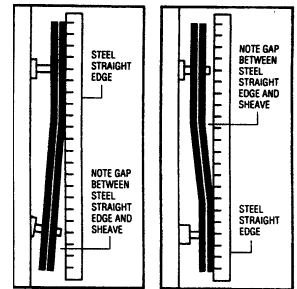

FIGURE 1 FIGURE 2

8. Misalignment will show up as a gap between the pulley face and the straight edge.

9. Make sure that the width of the outside land (Area between the belt and the edge of the pulley) is equal on both pulleys.

D. Depth Control

The cutting depth is controlled by a chrome turn handle. It is located next to the push handle base, easily accessible from the rear of the saw. The handle must first be unlocked before it can be turned. It is locked by a black knob located on the operator's left side of the hand wheel near the base of the handle. This knob must be turned counter-clockwise to unlock the handle. Once unlocked rotating the handle clockwise will lower the cutting blade. Rotating it counter-clockwise will raise the cutting blade. When the proper cutting depth is achieved by reading the depth gauge, relock the turn handle to ensure a constant cutting depth throughout the cut.

The depth gauge can be found further down the shaft of the turn handle. This gauge will already be preset for an Ø10" blade, but it still must be calibrated by the user since blade diameters may vary. When using an Ø8" blade, the gauge must be readjusted from an Ø10" blade to an Ø8" blade. Simply loosen the black knob found near the collar of the gauge and slide it accordingly to achieve the proper reading.

The collar used to support the turn handle's screw should be checked after each use to make sure it is lubricated and turning freely. If more lubricant must be added, NLGI #2, aluminum complex type grease is recommended.

E. Dust Removal System Adjustment

The GC55 and GC2E are equipped with a fully adjustable non-scratching Dust removal system which helps stabilize the machine by pushing debris way from wheels and undercarriage of the machine. Depending on the surface and wear the Dust Removal System may need adjustments from time to time. The Dust removal

system consist of two Brushes located in front of the Front Wheels and a large Squeegee Assembly located under the machine and in front of the rear wheels. When this system is properly adjusted the front wheel Brushes, and the Rear Wheel Squeegee System will barely touch the work surface.

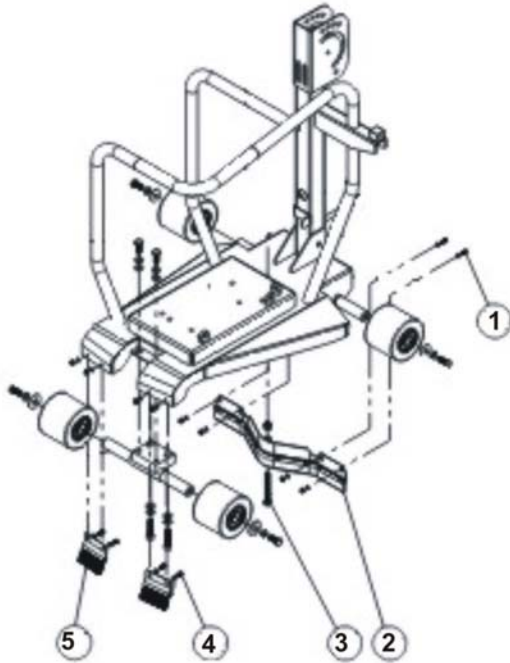

Before making any adjustments turn off the machine and disconnect the spark plug.

To adjust the Rear Wheel Squeegee Assembly:

1. Loose the Squeegee Assembly mounting hardware items 1 & 3
2. Position the Squeegee Assembly to the required position
3. Tighten the Squeegee Assembly mounting hardware items 1 & 3

To adjust the Front Wheel Brush:

1. Loose the Front Wheel Brush mounting hardware
2. Position the Front Wheel Brush to the required position
3. Tighten the Front Wheel Brush mounting hardware

NOTE: The Left and Right Side Front Wheel Brushes Are Different Parts

IV. PARTS LIST SECTION

A. Ordering Information

1. List model number and serial number of machine.
2. Provide the **UPC number**, part number, and description of part.
3. Wherever alternate parts are shown due to product improvement, inspect the part you have and provide additional description as necessary.
4. Specify mode of shipping desired, such as, parcel post, truck, U.P.S., best way, etc.

For the nearest Clipper distributor call 1-800-554-8003

Common Replacement Parts

Part No	UPC No.	Description	Type
233041	70184680905	WRENCH UNIVERSAL	S
241081	70184644460	LOOSE COLLAR GC55/GC25E	S
241082	70184644461	TIGHT COLLAR GC55/GC25E	S
241083	70184645330	NUT 5/8-11 UNC HEX LEFT HAND THREAD	S
241001	70184644991	GUARD BLADE GC55/GC25E	S
241016	70184640688	BLADE SHAFT GC55/GC25E	S
212142	70184650408	BEARING RADIAL 6204-RS	W
241023	70184644463	HAND WHEEL GC55/GC25E	S
241026	70184643282	BELLOWS GC55/GC25E	W
241029	70184642615	KNOB W/THREADED STUD M6 X 40 1.0	S
241032	70184642616	KNOB W/THREADED HOLE M6 X 15 1.0	S
241037	70184645000	CUTTING HEAD FLANGE GC55	S
241085	70184640686	POINTER WELDMENT GC55/GC25E	S
241059	70184640275	SWITCH EMERGENCY STOP GC55	S
241061	70184643194	KNOB W/THREADED HOLE M10 X 1.5 X 50mm DIA	S
241044	70184645698	WHEEL W/BEARING GC55/GC25E	W
241035	70184693631	OIL DRAIN HOSE ASSY 5.5HP HONDA GC55	S

NOTE: All Parts Are Sold As Individual (each) Unless Noted Otherwise

All parts are designated as either Service Parts (S) or Wear Parts (W) in the Type column in the parts listing. Wear parts are worn out through normal use of the machine. The wear period depends on the intensity of use of the machine, handling, and maintenance of the machine. Wear parts must be serviced and eventually changed following the indications of the manufacturer. Any wear due to normal use of the machine will not be considered as a case of warranty for items designated as Wear Parts (W). For best performance and life Genuine Norton Clipper replacement parts should always be used. Changes to part specifications, are subject to change without notice.

Blades Use Only Norton Diamond Blades. Contact your local Norton Clipper Distributor or Norton Clipper at 1-800-554-8003 for the best blade for the application.

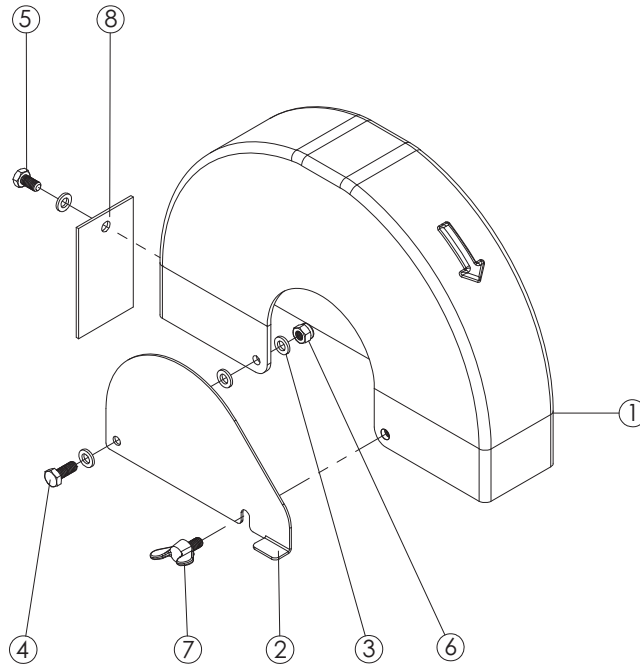

Blade Guard Assembly GC55 and GC25E

Item	Part No	UPC No.	Description	Qty	Type	Notes
1	241001	70184644991	GUARD BLADE GC55/GC25E	1	S	
2	241002	70184644990	BLADE SHAFT VENT COVER	1	S	
3	27539	70184600585	WASHER M6 DIN125 FLAT	4	S	
4	235048	70184646030	SCR M6 X 16 1.0 DIN933	1	S	
5	300566	70184624394	SCR M6 X 12 1.0 DIN933	1	S	
6	235136	70184600850	NUT M6 DIN985 LOCK	1	S	
7	241003	70184645236	SCR THUMB M6 X 12 1.0	1	S	
8	241004	70184695005	SPLASH GUARD GC55/GC25E	1	W	

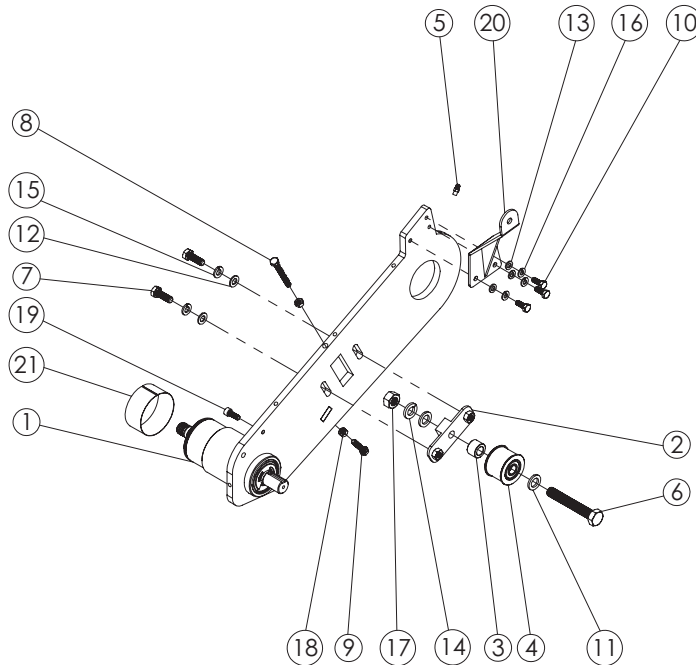

Cutting Head Assembly GC55 and GC25E

Item	Part No	UPC No.	Description	Qty	Type	Notes
1	241005	70184644256	BEARING CUTTING HEAD SUB ASSY – SEE PAGE 23 FOR PARTS	1	W	
2	241006	70184644849	PULLEY IDLER TENSION ADJUSTER	1	S	
3	241007	70184644850	SPACER INDLER GC55/GC25E	1	S	
4	241008	70184644851	PULLEY IDLER ASSEMBLY GC55/GC25E	1	S	
5	241009	70184647183	ZERK FITTING M6	1	S	
6	241010	70184642787	SCR M12 X 80 1.75 DIN933	1	S	
7	300323	70184624388	SCR M8 X 25 1.25 DIN933 FULL THD	2	S	
8	241011	70184645514	SCR M6 X 55 1.0 DIN933 DIN933 or DIN931?	1	S	
9	241012	70184647169	SCR M6 X 30 1.0 DIN933	1	S	
10	235048	70184646030	SCR M6 X 16 1.0 DIN933	3	S	
11	27505	70184681616	WASHER M12 DIN125 FLAT	2	S	
12	232110	70184600562	WASHER M8 DIN125 FLAT	2	S	
13	27539	70184600585	WASHER M6 DIN125 FLAT	3	S	
14	27017	70184681604	NUT LOCK M12 1.75 DIN985	1	S	
15	300245	70184625604	WASHER LOCK M8 DIN127	2	S	
16	300279	70184600756	WASHER LOCK M6 DIN127B	3	S	
17	27007	70184681603	NUT M12 1.75 DIN934 HEX	1	S	
18	300833	70184625661	NUT M6 1.0 DIN934 HEX	2	S	
19	232113	70184600567	SCR M6 X 16 1.0 DIN912 SHCS	1	S	
20	241013	70184646253	BRACKET DEPTH CONTROL MOUNT GC55	1	S	
	241100		BRACKET DEPTH CONTROL MOUNT GC25E	1	S	Call Customer Service
21	241014		BUSHING BLADE GUARD GC55/GC25E	1	S	Call Customer Service

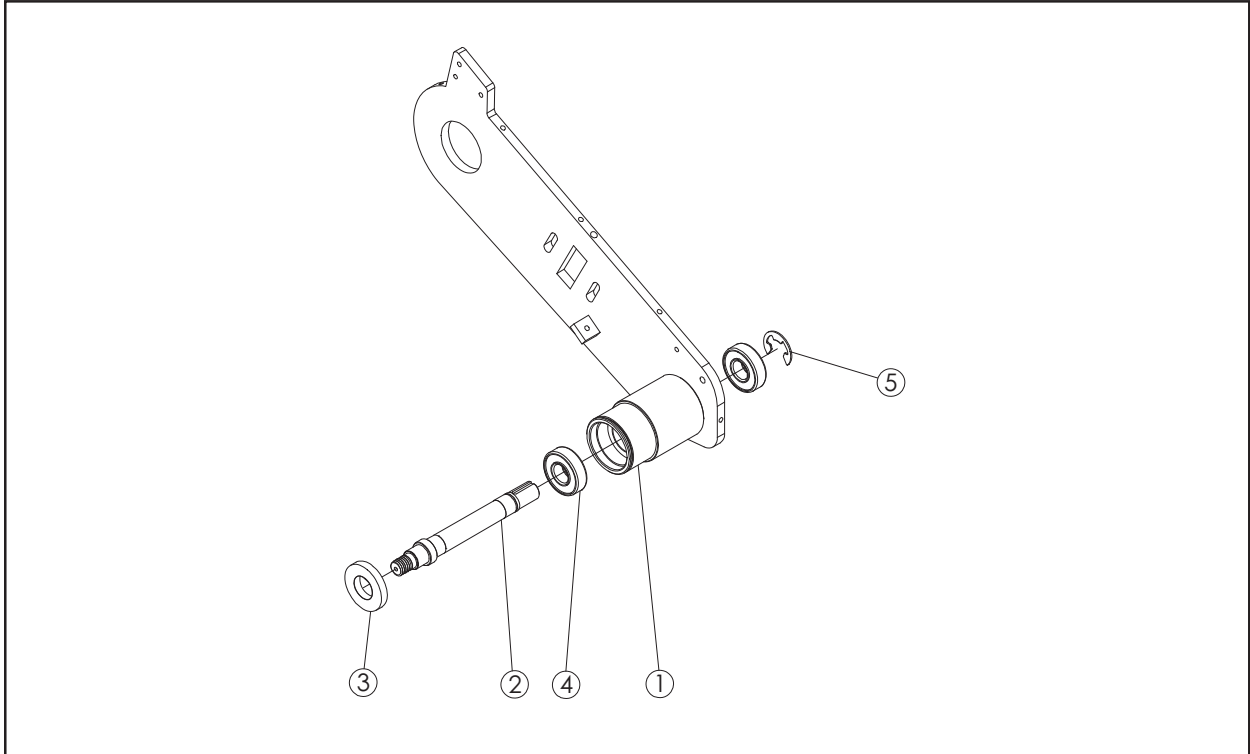

Blade Shaft Assembly GC55 and GC25E

Item	Part No	UPC No.	Description	Qty	Type	Notes
1	241015	70184647053	CUTTING HEAD ASSEMBLY GC55/GC25E	1	S	
2	241016	70184640688	BLADE SHAFT GC55/GC25E	1	W	
3	241017	70184643671	BEARING COVER BLADE SHAFT GC55/GC25E	1	S	
4	212142	70184650408	BEARING RADIAL 6204-RS	2	W	
5	241018	70184642838	RETAINING RING E-STYLE 19mm X 1.8mm DIN6799	1	S	

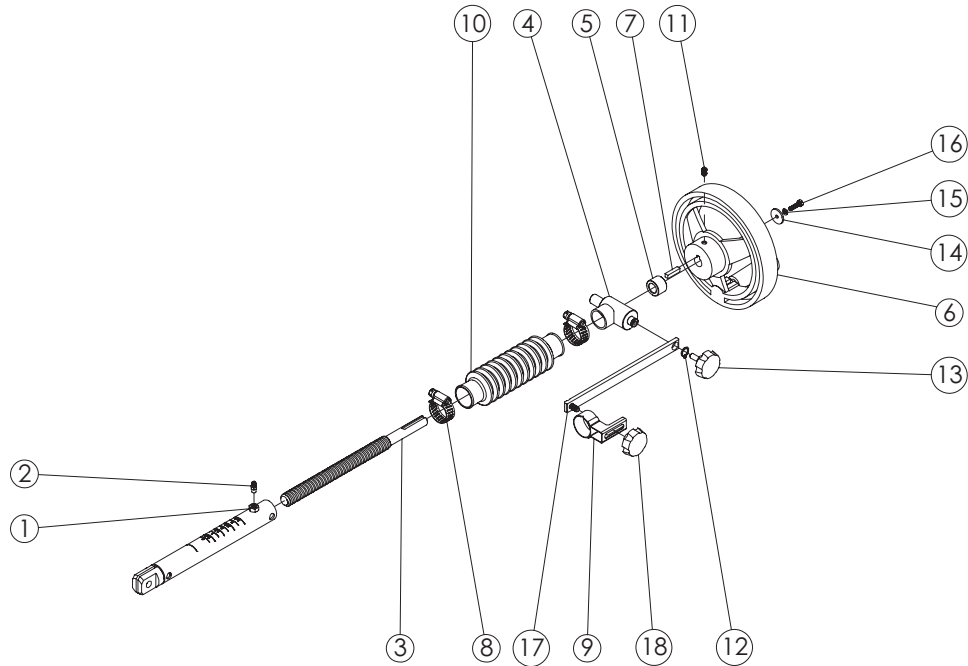

Depth Control Assembly GC55 and GC25E

Item	Part No	UPC No.	Description	Qty	Type	Notes
1	241090	70184644977	DEPTH TUBE GC55/GC25E	1	S	
2	241019		FIT GREASE ZERK M6 X 1.0	1	S	Call Customer Service
3	241020	70184644464	SCR DEPTH CONTROL GC55/GC25E	1	S	
4	241021	70184644978	DEPTH CONTROL MOUNT GC55/GC25E	1	S	
5	241022	70184644466	SPACER HAND WHEEL GC55/GC25E	1	S	
6	241023	70184644463	HAND WHEEL GC55/GC25E	1	S	
7	9201074	70184660346	KEY 3/16X3/4	1	S	
8	241024	70184693623	CLAMP HOSE 13/16" TO 1-3/4" X 1/2"W WORM	2	S	
9	241025	70184644980	DEPTH GAUGE POINTER GC55/GC25E	1	S	
10	241026	70184643282	BELLOWS GC55/GC25E	1	W	
11	241027	70184640684	SCR M5 X 10 0.8 DIN916 SET CUP POINT	1	S	
12	241028	70184645237	RETAINING RING C-STYLE 10mm X 1.0mm DIN471	1	S	
13	241029	70184642615	KNOB W/THREADED STUD M6 X 40 1.0	1	S	
14	241089	70184644465	WASHER M4 X 19mm X 2mm	1	S	
15	241030	70184647175	WASHER LOCK M4 DIN127	1	S	
16	235057	70184600786	SCR M4 X 16 0.7 DIN933	1	S	
17	241031	70184644979	DEPTH CONTROL POINTER BAR GC55/GC25E	1	S	
18	241032	70184642616	KNOB W/THREADED HOLE M6 X 15 1.0	1	S	

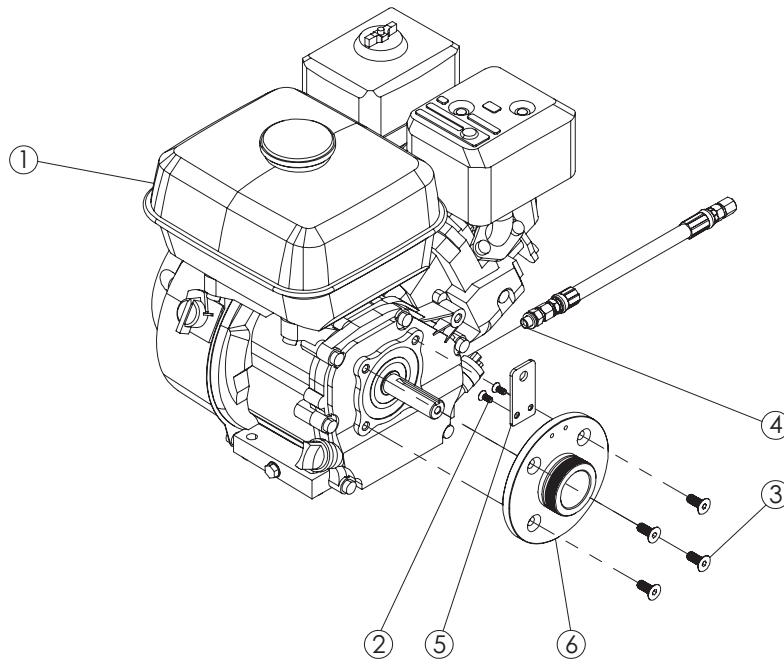

Engine Assembly GC55 Only

Item	Part No	UPC No.	Description	Qty	Type	Notes
1	216264	70184649829	ENG 5.5HP HONDA	1	S	GX160UT2QC9
2	241033		SCR M5 X 12 0.8 FLAT HEAD SOCKET CAP	2	S	Call Customer Service
3	231034	70184641374	SCR 5/16"-24 UNF X 3/4" C'SINK SOCKET HEAD	4	S	
4	241035	70184693631	OIL DRAIN HOSE ASSY 5.5HP HONDA	1	S	
5	241036	70184644999	BRACKET SELF LEVELING MOUNT GC55	1	S	
6	241037	70184645000	CUTTING HEAD FLANGE GC55	1	S	

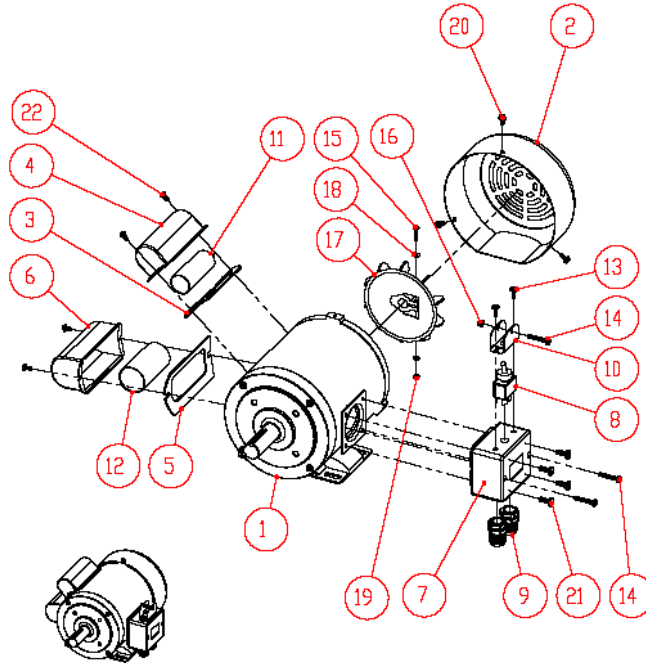

Motor Assembly GC25E

Item	Part No	UPC No.	Description	Qty	Type	Notes
1	241112	70184647149	MOT 2.5HP 115-230v/60/1 GC25E COMPLETE MOTOR (ITEMS 2 to 21)	1	S	
2	241113		COVER FAN GC25E	1	S	Call Customer Service
3	241114		GASKET RUN CAPACITOR COVER GC25E	1	W	Call Customer Service
4	241115		COVER RUN CAPACITOR GC25E	1	S	Call Customer Service
5	241116		GASKET START CAPACITOR COVER GC25E	1	W	Call Customer Service
6	241117		COVER START CAPACITOR GC25E	1	S	Call Customer Service
7	241118		BOX VOLTAGE CHANGE SWITCH BOX	1	S	Call Customer Service
8	241119		TOGGLE SWITCH GC25E	1	W	Call Customer Service
9	241120		CABLE GLAND PG-11	2	S	Call Customer Service
10	241121		GUARD SWITCH GC25E	1	S	Call Customer Service
11	241122		CAPACITOR RUN GC25E	1	W	Call Customer Service
12	241123		CAPACITOR START GC25E	1	W	Call Customer Service
13	241124		SCR 10-24 X 3/8 PHILLIPS ROUND HEAD	2	S	Call Customer Service
14	241125		SCR M5 X 40 0.8 DIN7985 PH PHILLIPS	3	S	Call Customer Service
15	241126		SCR M5 X 40 0.8 DIN7985 PH PHILLIPS	1	S	Call Customer Service
16	241127		NUT M5 0.8 LOCK DIN985	1	S	Call Customer Service
17	241128		FAN GC25E	1	S	Call Customer Service
18	235104	70184600873	WASHER M4 DIN125 FLAT	2	S	
19	241129		NUT M4 0.7 DIN934	1	S	Call Customer Service
20	241124		SCR 10-24 X 3/8 PHILLIPS ROUND HEAD	3	S	Call Customer Service
21	241125		SCR M6 X 16 1.0 DIN7985 PH PHILLIPS	4	S	Call Customer Service
22	241125		SCR 10-24 X 1/4 PHILLIPS ROUND HEAD	4	S	Call Customer Service

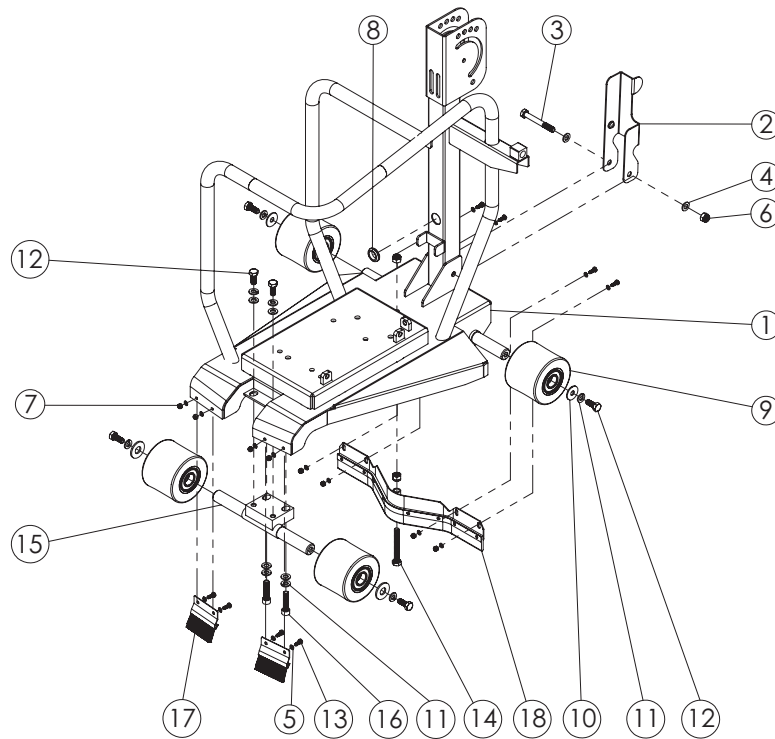

Frame Assembly GC55 Only

Item	Part No	UPC No.	Description	Qty	Type	Notes
1	241038	70184602100	FRAME GC55	1	S	Call Customer Service
2	241039	70184644992	REAR POINTER GC55/GC25E	1	S	
3	241040		SCR M8 X 65 1.25 DIN931 HEX HEAD CAP	1	S	Call Customer Service
4	232110	70184600562	WASHER M8 DIN125 FLAT	6	S	
5	235104	70184600873	WASHER M4 DIN125 FLAT	16	S	
6	241041	70184640778	NUT M8 1.25 LOCK DIN985	3	S	
7	241042		NUT M4 0.7 LOCK DIN985	8	S	Call Customer Service
8	241043		GROMMET GC55	1	S	Call Customer Service
9	241044	70184645698	WHEEL W/BEARING GC55/GC25E	4	W	
10	241045	70184625604	WASHER M8 X 24MM OD DIN9021B	4	S	
11	300245	70184625604	WASHER LOCK M8 DIN127	8	S	
12	235013	70184600735	SCR M8 X 20 1.25 DIN933 HEX HEAD CAP	6	S	
13	235103	70184600872	SCR M4 X 12 0.7 DIN933 HEX HEAD CAP	8	S	
14	232108	70184600560	SCR M8 X 65 1.25 DIN931 HEX HEAD CAP	1	S	
15	241046	70184644994	FRONT AXLE GC55/GC25E	1	S	
16	241047		SCR M8 X 35 1.25 SOCKET HEAD CAP DIN912	2	S	Call Customer Service
17	241048	70184641217	BRUSH WHEEL OPERATOR'S RIGHT GC55/GC25E	1	W	
18	241049	70184641218	BRUSH WHEEL OPERATOR'S LEFT GC55/GC25E	1	W	
19	241050	70184640818	SQUEEGEE ASSEMBLY ONLY GC55/GC25E	1	W	

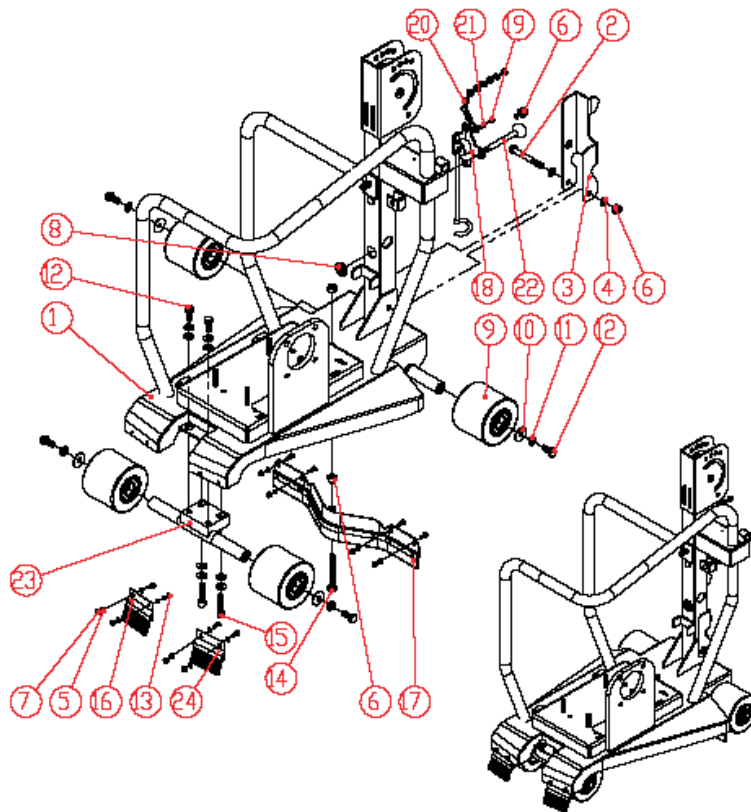

Frame Assembly GC25E Only

Item	Part No	UPC No.	Description	Qty	Type	Notes
1	241101		FRAME GC25E	1	S	Call Customer Service
2	232108	70184600560	SCR M8 X 65 1.25 DIN931 HEX HEAD CAP	1	S	
3	241039	70184644992	REAR POINTER GC55	1	S	
4	232110	70184600562	WASHER M8 DIN125 FLAT	7	S	
5	235104	70184600873	WASHER M4 DIN125 FLAT	17	S	
6	241041	70184640778	NUT M8 1.25 LOCK DIN985	4	S	
7	241042		NUT M4 0.7 LOCK DIN985	8	S	Call Customer Service
8	241058		GROMMET GC55	1	S	Call Customer Service
9	241044	70184645698	WHEEL W/BEARING GC55	4	W	
10	241045		WASHER M8 X 24MM OD DIN9021B	4	S	Call Customer Service
11	300245	70184625604	WASHER LOCK M8 DIN127	8	S	
12	235013	70184600735	SCR M8 X 20 1.25 DIN933 HEX HEAD CAP	6	S	
13	235103	70184600872	SCR M4 X 12 0.7 DIN933 HEX HEAD CAP	8	S	
14	241040		SCR M8 X 65 1.25 DIN931 HEX HEAD CAP	1	S	Call Customer Service
15	241047		SCR M8 X 35 1.25 SOCKET HEAD CAP DIN912	2	S	Call Customer Service
16	241048	70184641217	BRUSH WHEEL OPERATOR'S RIGHT GC55	1	W	
17	241050	70184640818	SQUEEGEE ASSEMBLY ONLY GC55	1	W	
18	241102		POWER CABLE SUSPENSION ARM GC25E	1	S	Call Customer Service
19	235099	70184600898	SCR M4 X 8 0.7 DIN966 PHILIPS	1	S	Call Customer Service
20	241056		CHAIN FOR QUICKRELEASE PIN 9" LONG GC55	1	S	
21	241030	70184647175	WASHER LOCK M4 DIN127	1	S	
22	241092	70184645614	PIN QUICKRELEASE 5/16" X 2" GRIP LENGTH	1	S	
23	241046	70184644994	FRONT AXLE GC55	1	S	
24	241049	70184641218	BRUSH WHEEL OPERATOR'S LEFT GC55	1	W	

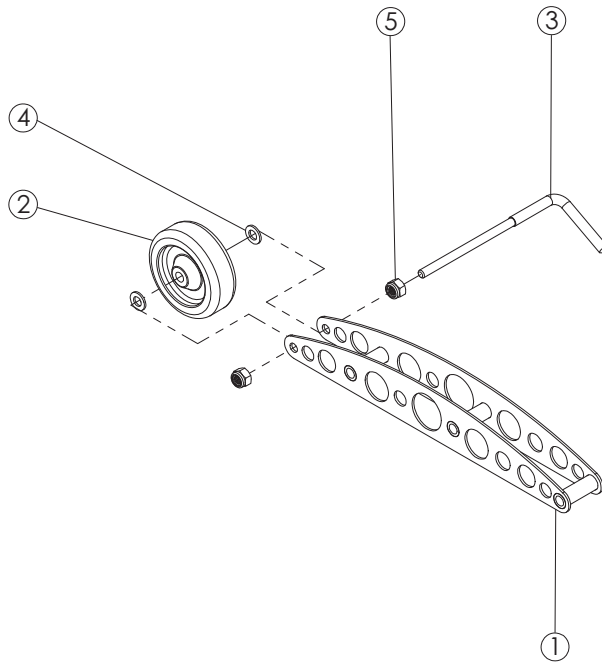

Front Pointer Assembly GC55 and GC25E

Item	Part No	UPC No.	Description	Qty	Type	Notes
1	241085	70184640686	POINTER WELDMENT GC55/GC25E	1	S	
2	241086	70184640776	WHEEL 75X28X8mm	1	W	
3	241087	70184640777	FRONT POINTER ROD GC55/GC25E	1	S	
4	232110	70184600562	WASHER M8 DIN125 FLAT	2	S	
5	241041	70184640778	NUT M8 1.25 LOCK DIN985	2	S	

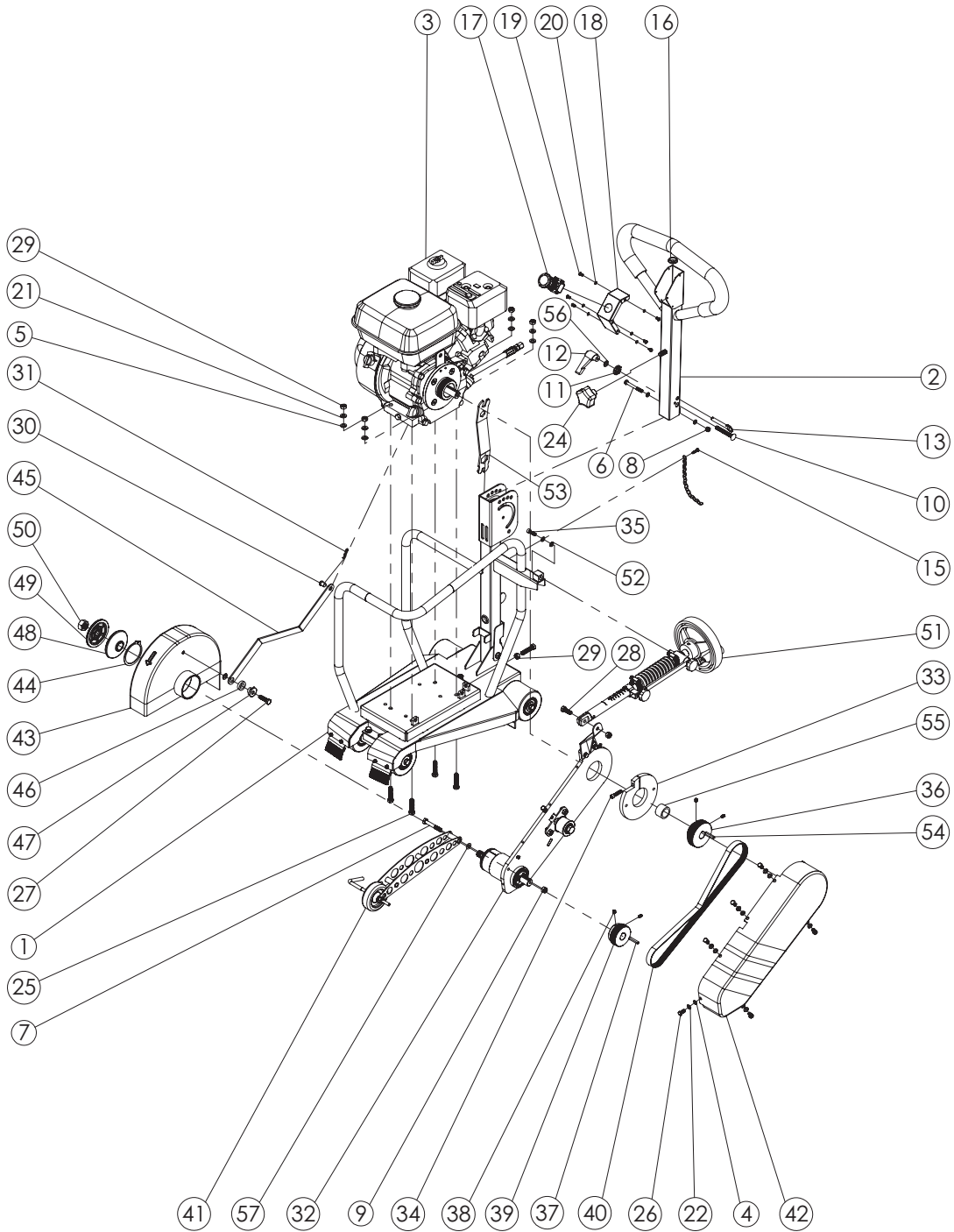

Main Assembly GC55 Only

Main Assembly GC55 Only

Item	Part No	UPC No.	Description	Qty	Type	Notes
1	-NA-		SEE FRAME ASSY GC55 PAGE 30	1		Call Customer Service
2	241052	70184640274	HANDLE BAR GC55	1	S	
3	-NA-		ENGINE ASSEMBLY GC55 SEE PAGE 28	1		Call Customer Service
4	27539	70184600585	WASHER M6 DIN125 FLAT	8	S	
5	232110	70184600562	WASHER M8 DIN125 FLAT	6	S	
6	241011	70184600563	SCR M6 X 55 1.0 DIN933 HEX HEAD CAP	1	S	
7	360146	70184626008	SCR M8 X 60 1.25 DIN933 HHC FULL THD	1	S	
8	235136	70184600850	NUT M6 DIN985 LOCK	1	S	
9	241041	70184640778	NUT M8 1.25 LOCK DIN985	2	S	
10	241054	70184645612	SCR 5/16-18 UNC X 2-1/2" CARRIAGE BOLT	1	S	
11	241055	70184645613	WASHER 3/8 WAVE	1	S	
12	241091	70184644996	KNOB M8 X 1.25 ADJUSTABLE	1	S	
13	241092	70184645614	PIN QUICKRELEASE 5/16" X 2" GRIP LENGTH	1	S	
14	241056		CHAIN FOR QUICKRELEASE PIN 9" LONG	1	S	
15	241057		SCR NO18-18 X 3/4" SELF DRILLING ROUND HD	1	S	Call Customer Service
16	241058		GROMMENT GC55	1	S	Call Customer Service
17	241059	70184640275	SWITCH EMERGENCY STOP GC55	1	W	
18	241060		SWITCH PANEL GC55	1	S	
19	235099	70184600898	SCR M4 X 8 0.7 DIN966 PHILIPS	6	S	
20	241030		WASHER LOCK M4 DIN127	6	S	Call Customer Service
21	300245	70184625604	WASHER LOCK M8 DIN127	4	S	
22	300279	70184600756	WASHER LOCK M6 DIN127B	7	S	
23	EE10110	70184684508	DIAMOND BLADE 10"x0.110x1-7/8-5/8 For Green Concrete	1	W	
24	241061	70184643194	KNOB W/THREADED HOLE M10 X 1.5 X 50mm	1	S	
25	235009	70184600732	SCR M8 X 40 1.25 DIN933	5	S	
26	241062	70184640687	SCR M6 X 14 1.0 DIN933	6	S	
27	241063	70184647177	SCR M8 X 30 1.25 DIN933	1	S	
28	300323	70184625643	SCR M8 X 25 1.25 DIN933 HHC FULL THD	1	S	
29	300273	70184625643	NUT M8 1.25 DIN934 HEX	5	S	
30	241064	70184647171	PIN CLEVIS 9.5MM D X 11L - 6.9MM USABLE LG	1	S	
31	241065	70184647172	HAIR PIN COTTER 1/4 TO 1/2 DIA X 0.062 X 1-5/16L	1	S	
32	-NA-		SEE CUTTING HEAD ASSEMBLY PAGE 25	1	S	Call Customer Service
33	241067	70184644997	COLLAR LOCK GC55	1	S	
34	241068	70184647174	SCR M6 X 30 1.0 DIN912 SOCKET HEAD HEX	1	S	
35	241069	70184647173	SCR M6 X 20 1.0 DIN912 SOCKET HEAD HEX	1	S	
36	241070	70184643672	PULLEY 70MM D X 3/4B 6G J SECTION	1	W	
37	9201074	70184660346	KEY 3/16X3/4	1	S	

Main Assembly GC55 Only

Item	Part No	UPC No.	Description	Qty	Type	Notes
38	241027	70184640684	SCR M5 X 10 0.8 DIN916 CUP POINT SET	4	S	
39	241071	70184640683	PULLEY 56.5MM D X 3/4B 6G J SECTION	1	W	
40	241072	70184640685	BELT 350J6 - J SECTION 6 GROOVE	1	W	
41	-NA-		SEE FRONT POINT ASSEMBLY PAGE 32	1	S	Call Customer Service
42	241074	70184644976	BELT GUARD GC55	1	S	
43	-NA-		SEE BLADE GUARD ASSEMBLY PAGE 24	1	S	Call Customer Service
44	241076	70184647178	RETAINING RING C-STYLE 60mm X 2.0mm DIN471	1	S	
45	241078	70184640682	ARM STAY LEVEL GC55/GC25E	1	S	
46	241079	70184645238	SPACER M14	1	S	
47	241080	70184645239	CAM STAY LEVEL GC55/GC25E	1	S	
48	241082	70184644461	TIGHT COLLAR GC55/GC25E	1	W	
49	241081	70184644460	LOOSE COLLAR GC55/GC25E	1	W	
50	241083	70184645330	NUT 5/8-11 UNC HEX LEFT HAND THREAD	1	S	
51	-NA-		SEE DEPTH CONTROL ASSEMBLY PAGE 27	1	S	Call Customer Service
52	27539	70184600585	WASHER M6 DIN 125 FLAT	1	S	
53	233041	70184680905	WRENCH UNIVERSAL	1	W	
54	9201080	70184662750	KEY 3/16X1 ¼	1	S	
55	241088		SPACER SHAFT GC55/GC25E	1	S	Call Customer Service
56	232110	70184600562	WASHER M8 DIN125 FLAT	1	S	
57	232110	70184600563	WASHER M8 DIN125 FLAT	1	S	

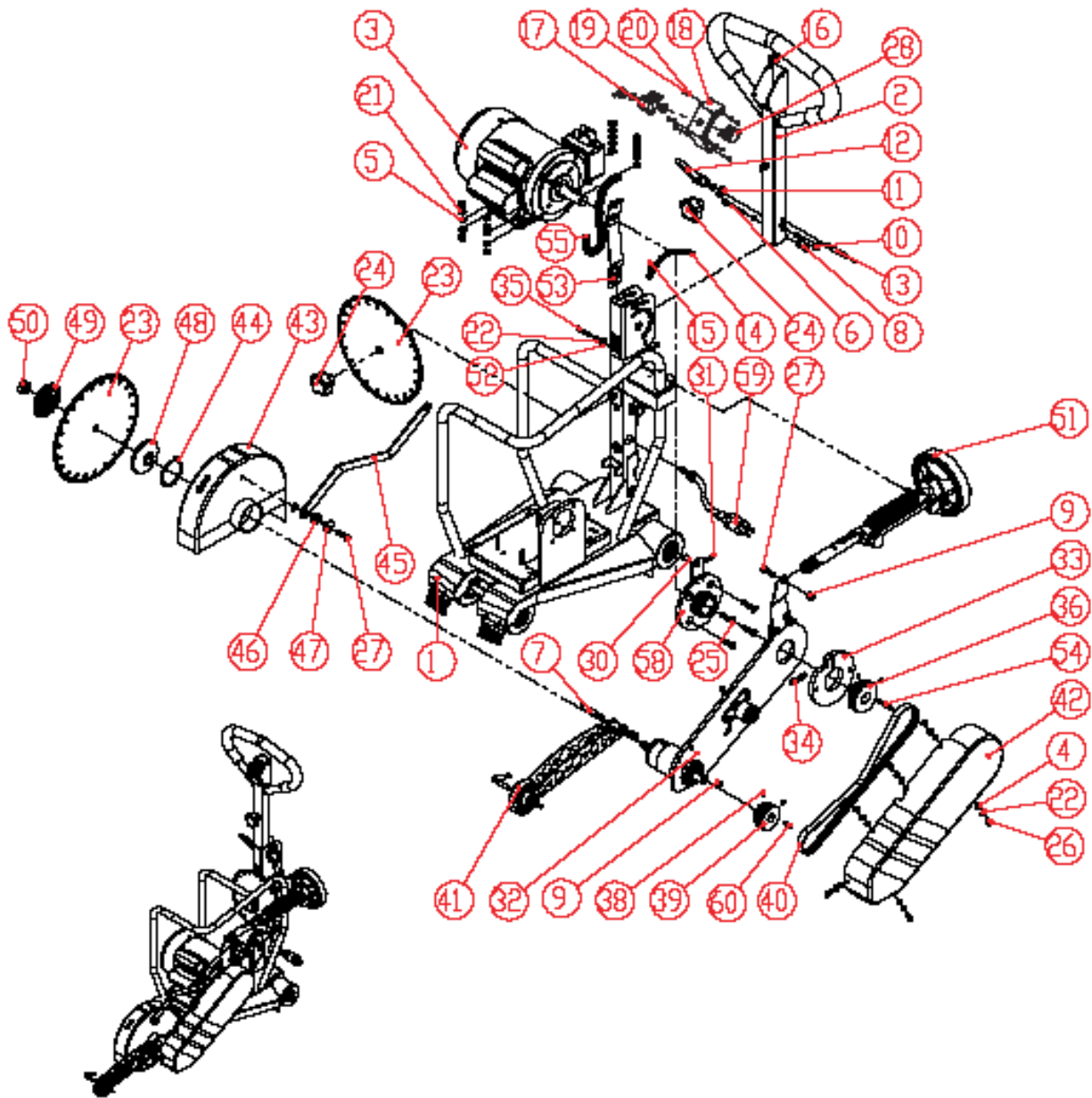

Main Assembly GC25E Only

Item	Part No	UPC No.	Description	Qty	Type	Notes
1	-NA-		SEE FRAME ASSEMBLY GC25E PAGE 31	1	S	Call Customer Service
2	241052	70184640274	HANDLE BAR GC55	1	S	
3	-NA-		SEE MOTOR ASSEMBLY GC25E PAGE 29	1	S	Call Customer Service
4	27539	70184600585	WASHER M6 DIN125 FLAT	8	S	
5	232110	70184600562	WASHER M8 DIN125 FLAT	12	S	
6	27030B	70184681621	SCR M10 X 60 1.5 DIN931	1	S	
7	360146	70184626008	SCR M8 X 60 1.25 DIN933 HHC FULL THD	1	S	

Item	Part No	UPC No.	Description	Qty	Type	Notes
8	235136	70184600850	NUT M6 DIN985 LOCK	1	S	
9	241041	70184640778	NUT M8 1.25 LOCK DIN985	2	S	
10	241054	70184650399	SCR 5/16-18 UNC X 2-1/2" CARR BOLT	1	S	
11	241055	70184650400	WASHER 3/8 WAVE	1	S	
12	241091	70184644996	KNOB M8 X 1.25 ADJUSTABLE	1	S	
13	241092	70184645614	PIN QUICKRELEASE 5/16" X 2" L	1	S	
14	241056		CHAIN FOR QUICKRELEASE PIN 9" L	1	S	
15	241057		SCR NO18-18 X 3/4" SELF DRILLING ROUND HEAD	1	S	
16	241058		GROMMET GC55	1	S	
17	241104		SHIELD POWER SWITCH GC25E	1	S	
18	241105		PANEL POWER SWITCH GC25E	1	S	
19	235099	70184600898	SCR M4 X 8 0.7 DIN966 PHILIPS	6	S	
20	241030	70184625604	WASHER LOCK M4 DIN127	6	S	
21	300245	70184625604	WASHER LOCK M8 DIN127	4	S	
22	300279	70184600756	WASHER LOCK M6 DIN127B	7	S	
23	EE10110	70184684508	DIAMOND BLADE 10"x0.110x1-7/8-5/8 For Green Concrete	1	W	
24	241061	70184643194	KNOB W/THREADED HOLE M10 X 1.5 X 50mm DIA	2	S	
25	241106	70184643566	SCR M8 X 35 1.25 SHCS DIN7991	4	S	
26	241062	70184640687	SCR M6 X 14 1.0 DIN933	6	S	
27	241063	70184647177	SCR M8 X 30 1.25 DIN933	2	S	
28	235165	70184623912	SWITCH TOGGLE (POWER) 20A	1	W	
30	241064	70184647171	PIN CLEVIS 9.5MM D X 11L - 6.9MM USABLE LENGTH	1	S	
31	241065	70184647172	HAIR PIN COTTER 1/4 TO 1/2 DIA x 0.062 x 1-5/16L	1	S	
32	-NA-		SEE CUTTING HEAD ASSEMBLY GC25E PAGE 25	1	S	Call Customer Service
33	241067	70184644997	COLLAR LOCK GC55	1	S	
34	241068	70184647174	SCR M6 X 30 1.0 DIN912 SCK HD HEX	1	S	
35	241069	70184647173	SCR M6 X 20 1.0 DIN912 SCKT HD HEX	1	S	
36	241070	70184643672	PULLEY 70MM D X 3/4B 6G J SECTION	1	W	
38	241027	70184640684	SCR M5 X 10 0.8 DIN916 SET CUP POINT	4	S	
39	241071	70184640683	PULLEY 56.5MM D X 3/4B 6G J SECTION	1	W	
40	241072	70184640685	BELT 350J6 - J SECTION 6 GROOVE	1	W	
41	241073	70184694075	SEE FRONT POINT ASSEMBLY PAGE 27	1	S	
42	241074	70184644976	BELT GUARD GC55	1	S	
43	241075		BLADE GUARD ASSEMBLY GC55	1	S	
44	241076	70184647178	RETAINING RING C-STYLE 60mm X 2.0mm DIN471	1	S	

Item	Part No	UPC No.	Description	Qty	Type	Notes
45	241078	70184640682	ARM STAY LEVEL GC55	1	S	
46	241079	70184645238	SPACER M14	1	S	
47	241080	70184645239	CAM STAY LEVEL GC55	1	S	
48	241081	70184644460	TIGHT COLLAR GC55/GC25E	1	W	
49	241082	70184644461	LOOSE COLLAR GC55/GC25E	1	W	
50	241083	70184645330	NUT 5/8-11 UNC HEX LEFT HAND THREAD	1	S	
51	241084	70184694074	DEPTH CONTROL ASSEMBLY GC55	1	S	
52	27539	70184600585	WASHER M6 DIN 125 FLAT	1	S	
53	233041	70184680905	WRENCH UNIVERSAL	1	W	
54	241108		KEY 5 X 5 X 45mm	1	S	
55	241109		CONDUIT 14.5mm D x 10mm ID FLEXIBLE	1	S	
58	241110		CUTTING HEAD FLANGE GC25E	1	S	
59	241111	70184647170	CABLE POWER W/FM TWIST LOCK GC25E	1	S	
60	9201074	70184660346	KEY 3/16X3/4	1	S	
61	241041	70184640778	NUT M8 1.25 LOCK DIN985	8	S	

NOTES

Saint-Gobain Abrasives
2770 West Washington
Stephenville, TX 76401
Phone: 800-554-8003
Fax: 800-443-1092



elipper®

WARNING

Some dust created by power sanding, sawing, grinding, drilling, and other construction activities contains chemicals known to cause cancer, birth defects or other reproductive harm. Some examples of these chemicals are:

- Lead from lead-based paints,
- Crystalline silica from bricks and cement and other masonry products, and
- Arsenic and chromium from chemically-treated lumber.

Your risk from these exposures varies, depending on how often you do this type of work. To reduce your exposure to these chemicals: work in a well ventilated area, and work with approved safety equipment, such as those dust masks that are specially designed to filter out microscopic particles.