

TILTING DRUM RING - TDR-30

APPROX WEIGHT: 18.34 lbs.
 DOES NOT INCLUDE WEIGHT OF POWER OR PACKAGING!!!

*** ANY ADDITIONS, DELETIONS, OR OMISSIONS MUST BE CORRECTED ON THIS DRAWING AS THIS DRAWING WILL BE CONSIDERED ALL INCLUSIVE ***
 ALL GRAPHICS PROVIDED ARE FOR REFERENCE ONLY. IF CERTAIN DIMENSIONS ARE CRITICAL PLEASE VERIFY THOSE DIMENSIONS WITH YOUR SALESPERSON

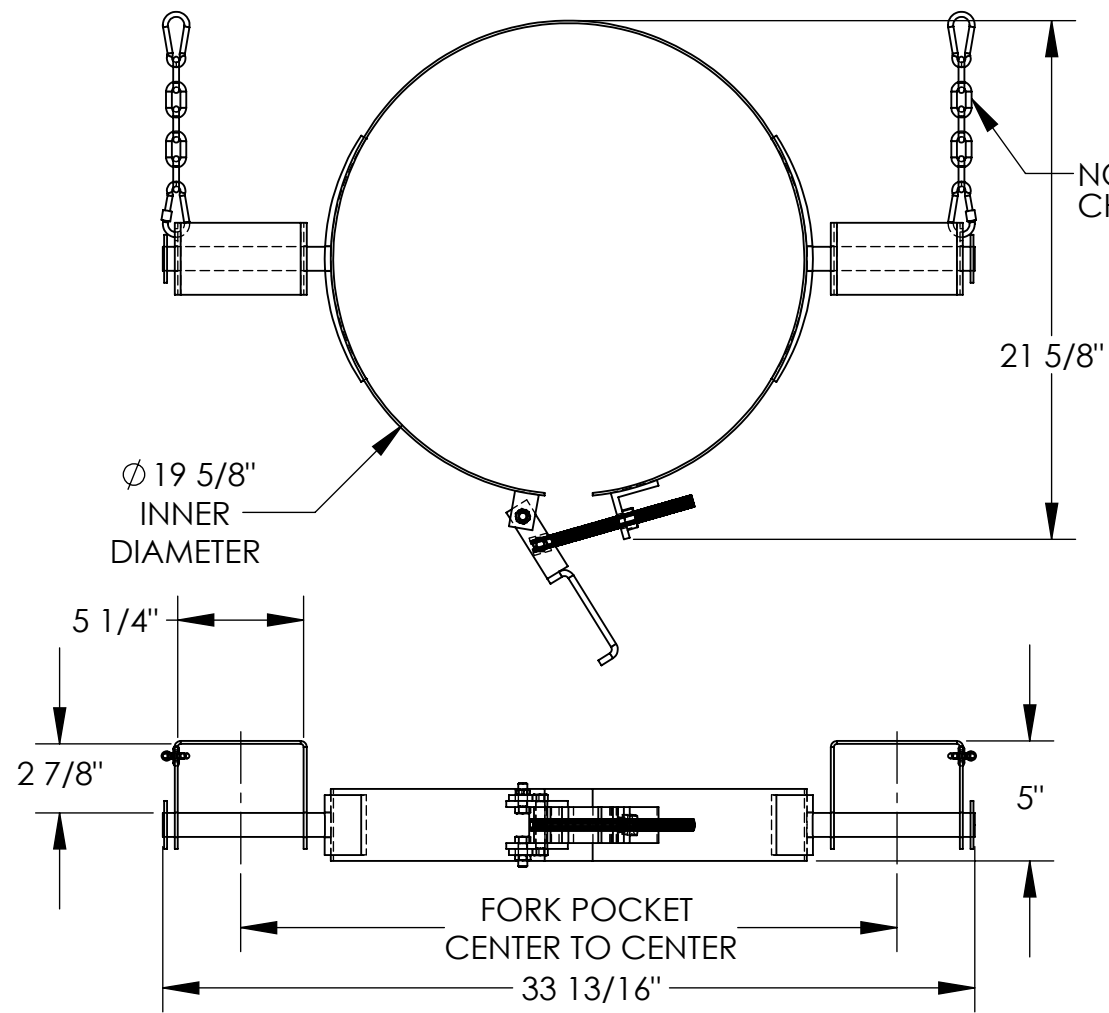

NOTE: FULL LENGTH OF CHAINS NOT SHOWN

ADJUSTABLE LATCH

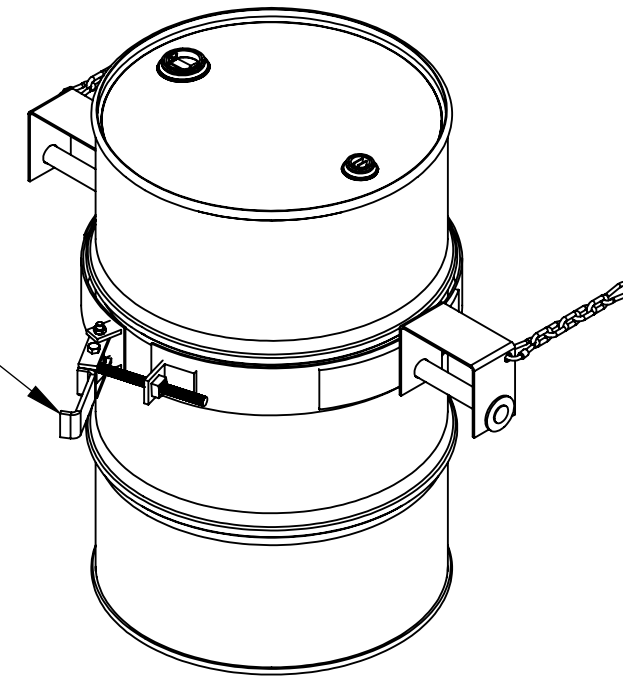

DRUM SHOWN FOR REFERENCE ONLY
 DRUM CAN BE PURCHASED SEPARATELY

DIMENSION TOLERANCE $\pm 1/4"$

STANDARD FEATURES

- MODEL NUMBER: TDR-30
- CAPACITY: 1,200 LBS.
- OVERALL WIDTH: 33 13/16"
- INNER DIAMETER: $\varnothing 19 5/8"$
- OVERALL HEIGHT: 5"
- FORK OPENING: 5 1/4"W x 2 7/8"H
- FORK POCKET CENTER MIN 25 1/2" MAX 26 7/8"
- INCLUDES (2) 42"L CHAINS
- FOR USE WITH 30 GALLON DRUMS
- DURABLE BAKED IN POWDERCOAT BLUE FINISH

SPECIAL FEATURES

NONE

APPROVAL	I, THE UNDERSIGNED, AGREE THAT THE PRODUCT AS REPRESENTED SATISFIES DESIGN AND DIMENSION REQUIREMENTS. I ALSO ACKNOWLEDGE MY DUTY TO CONFIRM PRODUCT AND INSTALLATION COMPLIANCE WITH ALL APPLICABLE FEDERAL, STATE AND LOCAL REGULATIONS AND STANDARDS.	
	UNITS REQUIRING APPROVAL DRAWINGS OR MODIFIED ARE NON-RETURNABLE	
	<input type="checkbox"/> As drawn	<input type="checkbox"/> As marked
	Signed: _____	Date: _____
Printed Name: _____		
LEAD TIME WILL START UPON RECEIPT OF SIGNED APPROVAL DRAWING		

DISTRIBUTOR'S NAME:		P.O.#
VESTIL MANUFACTURING		X
DRAWN BY: ND		W.O.#
DATE: 01/20/06		X
REFERENCE: X	SCALE: 1:8	SALES: X
QUOTED LEAD TIME: X	QUOTE #	FILE NAME:
	X	09-007-096