

# HEAVY DUTY WORK BENCH - FWT-P-025-3072

APPROX WEIGHT: 467.98 lbs.  
 DOES NOT INCLUDE WEIGHT OF POWER OR PACKAGING!!!

\*\*\* ANY ADDITIONS, DELETIONS, OR OMISSIONS MUST BE CORRECTED ON THIS DRAWING AS THIS DRAWING WILL BE CONSIDERED ALL INCLUSIVE \*\*\*

ALL GRAPHICS PROVIDED ARE FOR REFERENCE ONLY. IF CERTAIN DIMENSIONS ARE CRITICAL PLEASE VERIFY THOSE DIMENSIONS WITH YOUR SALESPERSON

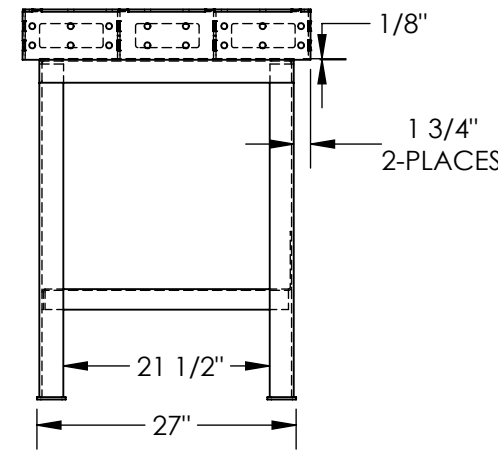
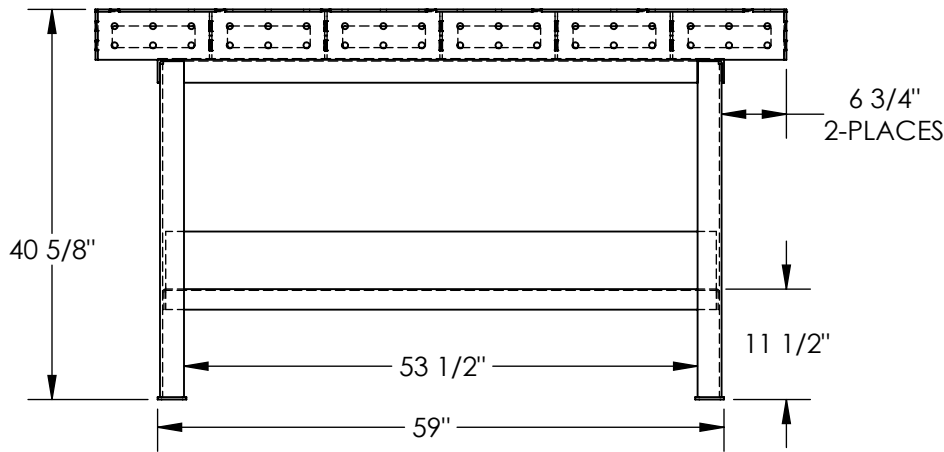
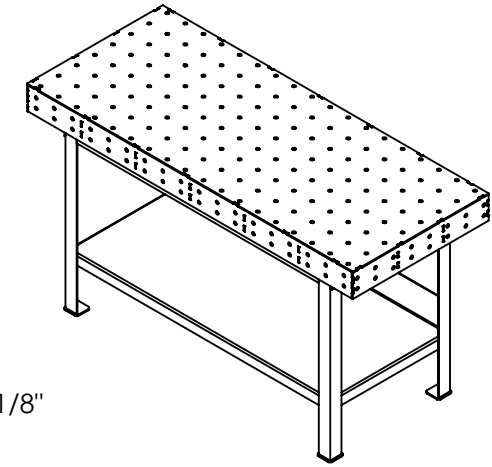
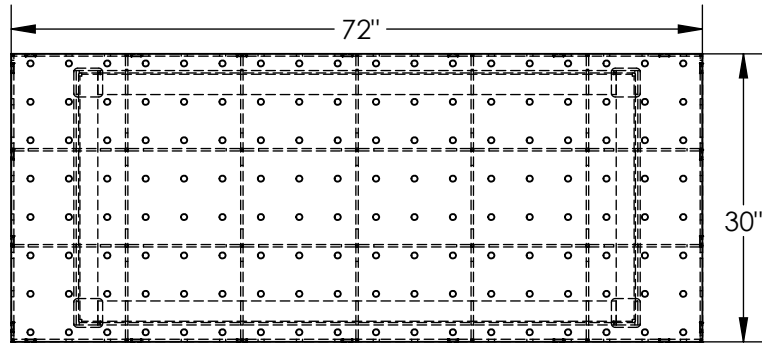

DIMENSION TOLERANCE  $\pm 1/4$ "

## STANDARD FEATURES

- MODEL NUMBER IS FWT-P-025-3072
- OVERALL WIDTH IS 30"
- OVERALL LENGTH IS 72"
- OVERALL HEIGHT IS 40 5/8"
- MAX CAPACITY IS 8,000 LBS
- HOLES FOR USE WITH  $\phi 5/8$ " AND  $\phi 16$ mm TOOLS
- DECK THICKNESS IS 1/4"
- TABLE TOP HOLE SPACING IS 4" X 4"
- TABLE SIDE HOLE SPACING IS 2" X 4"
- UNPAINTED STEEL CONSTRUCTION

## SPECIAL FEATURES

NONE

APPROVAL

I, THE UNDERSIGNED, AGREE THAT THE PRODUCT AS REPRESENTED SATISFIES DESIGN AND DIMENSION REQUIREMENTS. I ALSO ACKNOWLEDGE MY DUTY TO CONFIRM PRODUCT AND INSTALLATION COMPLIANCE WITH ALL APPLICABLE FEDERAL, STATE AND LOCAL REGULATIONS AND STANDARDS.

**UNITS REQUIRING APPROVAL DRAWINGS OR MODIFIED ARE NON-RETURNABLE**

As drawn       As marked

Signed: \_\_\_\_\_ Date: \_\_\_\_\_

Printed Name: \_\_\_\_\_

LEAD TIME WILL START UPON RECEIPT OF SIGNED APPROVAL DRAWING

DISTRIBUTOR'S NAME:		P.O.#
VESTIL MANUFACTURING		X
DRAWN BY: NBE		W.O.#
DATE: 11/12/2020		X
REFERENCE: X	SCALE: 1:20	SALES: X
QUOTED LEAD TIME: X	QUOTE #	FILE NAME:
	X	43-007-022