

MULTI PURPOSE LIFTING ATTACHMENT - MPLA-58-3000

APPROX WEIGHT: 294.96 lbs.
 DOES NOT INCLUDE WEIGHT OF POWER OR PACKAGING!!!

*** ANY ADDITIONS, DELETIONS, OR OMISSIONS MUST BE CORRECTED ON THIS DRAWING AS THIS DRAWING WILL BE CONSIDERED ALL INCLUSIVE ***

ALL GRAPHICS PROVIDED ARE FOR REFERENCE ONLY. IF CERTAIN DIMENSIONS ARE CRITICAL PLEASE VERIFY THOSE DIMENSIONS WITH YOUR SALESPERSON

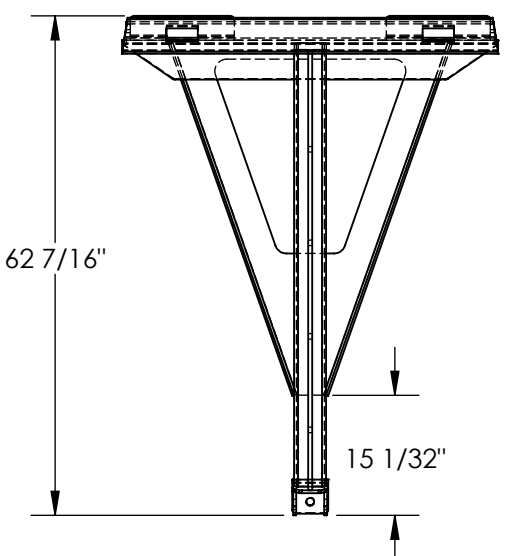
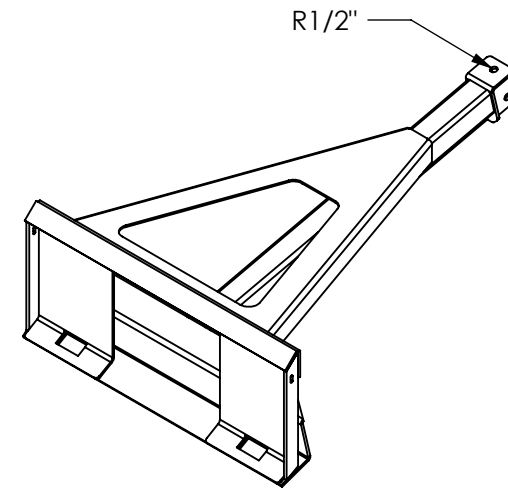
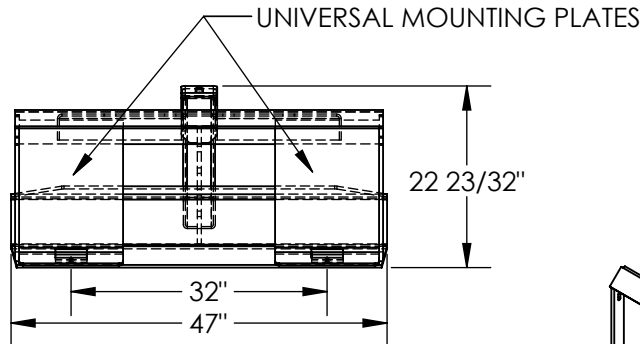
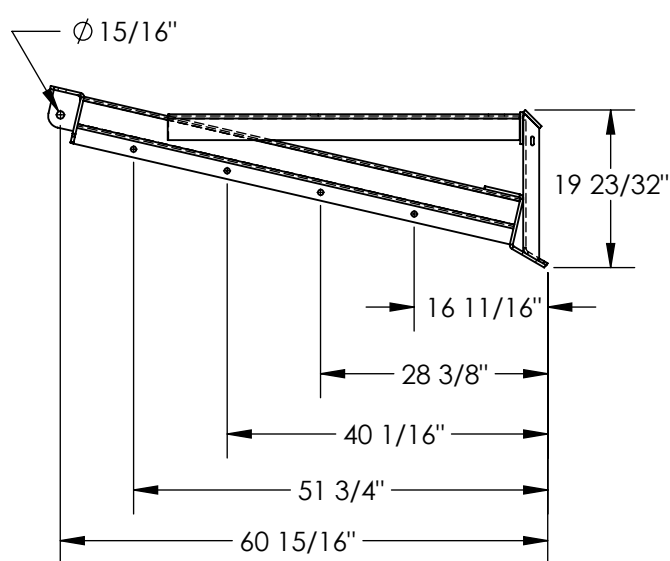

STANDARD FEATURES

- MODEL NUMBER IS MPLA-58-3000
- OVERALL WIDTH IS 47"
- OVERALL LENGTH IS 62 7/16"
- OVERALL HEIGHT IS 22 23/32"
- UNIVERSAL MOUNTING PLATE ON 32" CENTER
- MAX CAPACITY IS 3000 LBS
- TOUGH BAKED IN POWDER COAT BLUE FINISH

SPECIAL FEATURES

NONE

CAN BE USED WITH:

- HOOK-R-4
- HOOK-S-4
- BALL-178
- BALL-200
- BALL-2516

DIMENSION TOLERANCE ± 1/4"

| | | |
|---|--|-------------|
| APPROVAL | I, THE UNDERSIGNED, AGREE THAT THE PRODUCT AS REPRESENTED SATISFIES DESIGN AND DIMENSION REQUIREMENTS. I ALSO ACKNOWLEDGE MY DUTY TO CONFIRM PRODUCT AND INSTALLATION COMPLIANCE WITH ALL APPLICABLE FEDERAL, STATE AND LOCAL REGULATIONS AND STANDARDS. | |
| | UNITS REQUIRING APPROVAL DRAWINGS OR MODIFIED ARE NON-RETURNABLE | |
| | [] As drawn [] As marked | |
| | Signed: _____ | Date: _____ |
| Printed Name: _____ | | |
| LEAD TIME WILL START UPON RECEIPT OF SIGNED APPROVAL DRAWING | | |

| | | |
|----------------------|-------------|------------|
| DISTRIBUTOR'S NAME: | | P.O.# |
| VESTIL MANUFACTURING | | X |
| DRAWN BY: C.CLEMENS | | W.O.# |
| DATE: 4/21/2020 | | X |
| REFERENCE: X | SCALE: 1:24 | SALES: X |
| QUOTED LEAD TIME: X | QUOTE # | FILE NAME: |
| | X | 50-007-032 |