

HIGH STRENGTH 90° SELF DUMPING HOPPER - H-100-HS

APPROX WEIGHT: 366.58 lbs.
 DOES NOT INCLUDE WEIGHT OF POWER OR PACKAGING!!!

*** ANY ADDITIONS, DELETIONS, OR OMISSIONS MUST BE CORRECTED ON THIS DRAWING AS THIS DRAWING WILL BE CONSIDERED ALL INCLUSIVE ***
 ALL GRAPHICS PROVIDED ARE FOR REFERENCE ONLY. IF CERTAIN DIMENSIONS ARE CRITICAL PLEASE VERIFY THOSE DIMENSIONS WITH YOUR SALESPERSON

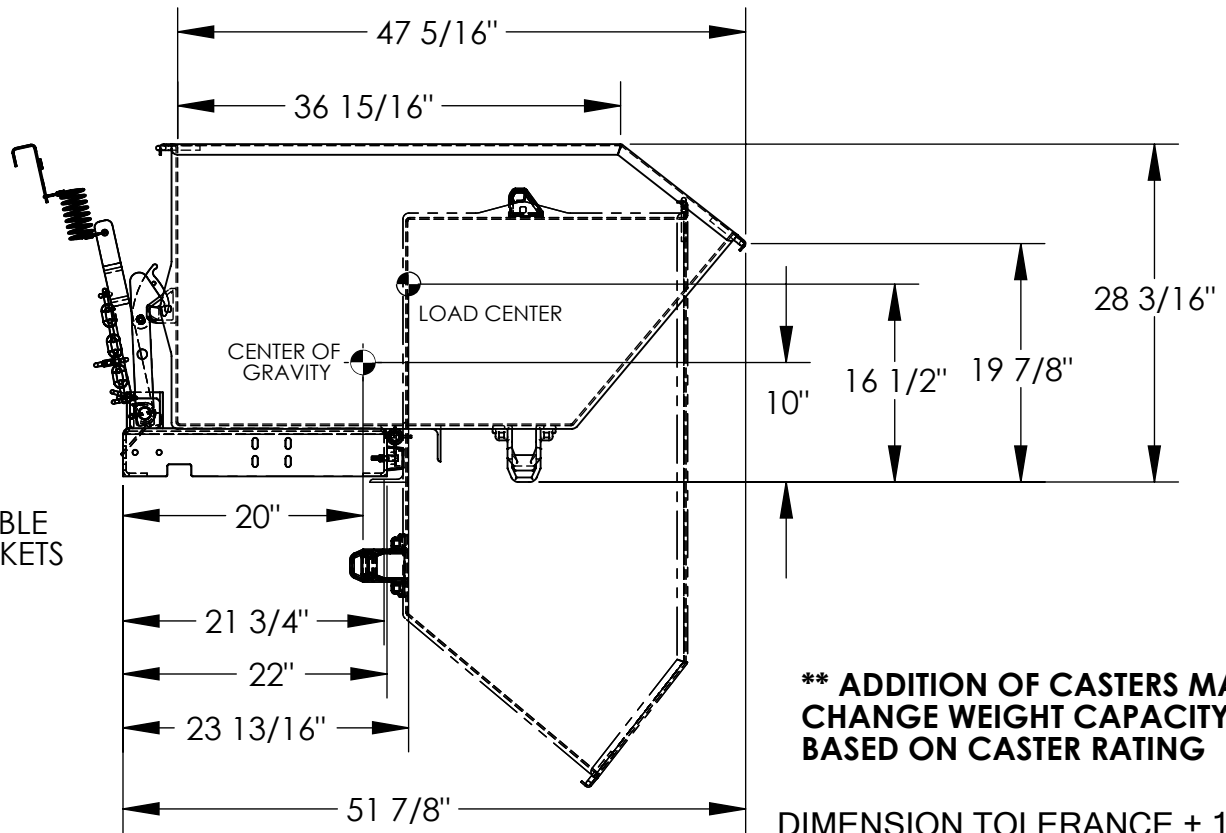
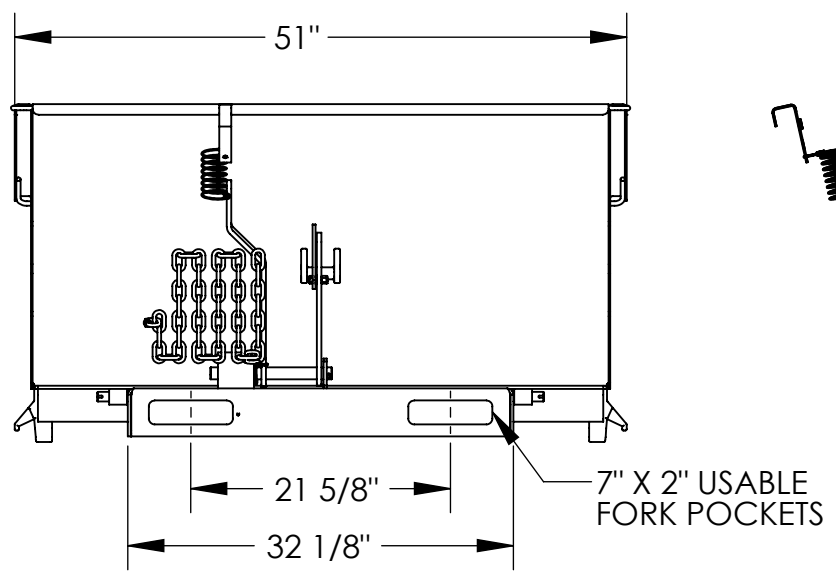

STANDARD FEATURES

- MODEL NUMBER: H-100-HS
- OVERALL WIDTH: 51"
- OVERALL LENGTH: 51 7/8"
- OVERALL HEIGHT: 28 3/16"
- CAPACITY: 6,000 LBS.
- VOLUME: 1 CU. YRD.
- DURABLE BAKED IN POWDER COATED BLUE FINISH
- APPROX. WEIGHT / LOST LOAD = 366.58
- MINIMUM EFFECTIVE THICKNESS = FORK LENGTH - 21 3/4"
- VERTICAL CENTER OF GRAVITY = 10"
- HORIZONTAL CENTER OF GRAVITY = 20"

NEVER EXCEED LOAD CENTER RATING PER FORKTRUCK MANUFACTURERS GUIDELINES.
 DO NOT USE THIS FORK TRUCK ATTACHMENT IF LOAD WILL EXCEED FORK TRUCK MANUFACTURER'S LOAD CENTER RATING

SPECIAL FEATURES
 NONE

**** ADDITION OF CASTERS MAY CHANGE WEIGHT CAPACITY BASED ON CASTER RATING**

DIMENSION TOLERANCE ± 1/4"

APPROVAL

I, THE UNDERSIGNED, AGREE THAT THE PRODUCT AS REPRESENTED SATISFIES DESIGN AND DIMENSION REQUIREMENTS. I ALSO ACKNOWLEDGE MY DUTY TO CONFIRM PRODUCT AND INSTALLATION COMPLIANCE WITH ALL APPLICABLE FEDERAL, STATE AND LOCAL REGULATIONS AND STANDARDS.
UNITS REQUIRING APPROVAL DRAWINGS OR MODIFIED ARE NON-RETURNABLE
 As drawn As marked

Signed: _____ Date: _____
 Printed Name: _____

LEAD TIME WILL START UPON RECEIPT OF SIGNED APPROVAL DRAWING

DISTRIBUTOR'S NAME:		P.O.#
VESTIL MANUFACTURING		X
DRAWN BY: JWW	DATE: 12/14/2020	W.O.#
REFERENCE: X	SCALE: 1:16	X
QUOTED LEAD TIME: X	QUOTE #	SALES: X
	X	FILE NAME:
		37-007-158