



FLAIL MOWER

BE-EFGCXXXF
BE-EFGCXXXH



OPERATIONS & PARTS MANUAL

FOR MODELS:

- BE-EFGC105F
- BE-EFGC125F
- BE-EFGC145F
- BE-EFGC155F
- BE-EFGC165F
- BE-EFGC175F
- BE-EFGC200F
- BE-EFGC125H
- BE-EFGC145H
- BE-EFGC155H
- BE-EFGC165H
- BE-EFGC175H
- BE-EFGC200H

PURCHASE DATE	MODEL NO.	SERIAL NUMBER
DEALER		

TABLE OF CONTENTS

3	SAFETY
9	PRODUCT SPECIFICATIONS
10	OPERATION
13	SERVICE & MAINTENANCE
15	STORAGE
16	TROUBLESHOOTING
17	EXPLODED VIEWS & PARTS LISTS

SAFETY PRECAUTIONS



Before operating the Flail Mower read the following safety instructions. Failure to comply with these warnings may result in serious injury or death.

Congratulations On the purchase of your new BE Flail Mower.

This information is to assist you in preparing, operating and maintaining your Flail Mower.

Please read and understand the information completely before operating your mower, paying special attention to all the safety details. Keep this manual handy for a ready reference.

SAFETY FIRST

YOU are responsible for the SAFE operation and maintenance of your flail mower. YOU must ensure that you and anyone else who is going to operate, maintain or work around the Flail Mower is familiar with the operating and maintenance procedures and related SAFETY information contained in this manual.

This manual will take you step-by-step through your working day and alert you to a good safety practices that should be adhered to while operating the Flail Mower.

Remember, YOU are the key to safety. Good safety practices not only protect you but also the people around you.

Make these practices a working part of your safety program. Be certain that EVERYONE operating this equipment is familiar with the recommended operating and maintenance procedures and follows all the safety precautions.

Most accidents can be prevented. Do not risk injury or death by ignoring safety practices.

Flail mower owner must give operating instructions to operators or employees before allowing them to operate the machine.

The most important safety feature on this equipment is a SAFE operator. It is the operator's responsibility to read and understand ALL Safety and Operating Instructions in the manual and follow these.

All accidents can be avoided.

A person who has not read and understood all operating and safety instructions is not qualified to operate the machine. An untrained operator jeopardizes himself and bystanders to possible serious injury or death.

Do not modify the equipment in any way. Unauthorized modification may weaken the function and/or safety and could affect the life of the equipment.

Think SAFETY! Work SAFELY!

GENERAL SAFETY

Read the operator's manual and all safety signs carefully before operating, maintaining, adjusting or removing the Flail Mower.

Do not allow passengers to ride on the Flail Mower.

Operate only at a safe distance from bystanders. Clear the area of people, especially children, before starting.

Stop PTO before dismounting tractor.

Keep hands and feet from under Flail Mower at all times.

Keep all shields in place. If shield removal becomes necessary for repairs, replace the shield prior to use.

Do not stay between the tractor and the Flail Mower.

Do not approach the Flail Mower until all motion has stopped.

All rotary blades have the ability to discharge objects at high speeds, which could result in serious injury to bystanders or passers-by, use extreme caution.

Place all controls in neutral, stop tractor engine, set park brake, remove ignition key and wait for all moving parts to stop before servicing, adjusting, repairing, attaching or removing.

Review safety related times annually with all personnel who will operate or maintain the Flail Mower.

Do not operate machine if you feel unwell or physically unfit, in which case you should stop working.

This machine was designed with safety very much in mind. However, there is no real substitute for caution and attention in preventing accidents. Once an accident has happened, it is too late to think about what you should have done.

Use a tractor equipped with a Roll Over Protective Structure (ROPS). Always wear your seatbelt.

Serious injury or even death could result from falling off the tractor - particularly during a turnover when the operator could be pinned under the ROPS or the tractor.

Never exceed the limits of a piece of machinery. If its ability to do a job, or to do so safely, is in question **DON'T TRY IT.**

Clear working area of stones, branches or hidden obstacles that might be hooked or snagged, causing injury or damage.

OPERATING SAFETY

Read and understand the Operator's Manual and all safety signs before operating, servicing, adjusting, repairing or removing.

Do not allow riders.

Install and secure all guards and shields before starting or operating.

Keep hands, feet, hair and clothing away from moving parts.

Place all controls in neutral, stop tractor engine, set park brake, remove ignition key and wait for all moving parts to stop before servicing, adjusting, repairing, attaching or removing.

Place tractor and machine controls in neutral before starting.

Never start or operate machine unless sitting on tractor's seat.

Clear the area of bystanders, especially small children, before starting.

Stay away from PTO shaft and machine when engaging PTO. Keep others away.

Use warning lights in tractor when transporting.

Do not put hands or feet under machine while tractor engine or machine is running.

Do not operate Flail Mower in the raised position.

Objects can be thrown out from under the machine with sufficient force to severely injure people.

Stay away from machine when it is running. Keeps others away.

Always know what you are cutting. Never operate Flail Mower in an area that has hidden obstacles.

Remove sticks, stones, wire or other objects from working area before starting.

Review safety instructions with all operators annually.

STORAGE SAFETY

Store the machine in an area away from human activity.

Do not permit children to play on or around the stored machine

Store the machine in a dry, level area.

Clean grease and oil as required and protect it from the elements.

MAINTENANCE SAFETY

Good maintenance is your responsibility. Poor maintenance is an invitation to trouble.

Follow good shop practices.

Keep service area clean and dry.

Be sure electrical outlets and tools are properly grounded.

Use adequate light for the job at hand.

Make sure there is plenty of ventilation. Never operate the engine of the tractor in a closed building.

The exhaust fumes may cause asphyxiation.

Before working on this machine, shut off the engine, set the brakes and remove the ignition key.

Never work under equipment unless it is secured by a mechanical stand.

Use personal protection devices such as eye, hand and hearing protectors, when performing any service or maintenance work. Use heavy gloves when handling blades.

Only use genuine parts for service and maintenance.

A fire extinguisher and first aid kit should be kept readily accessible while performing maintenance on this equipment.

Periodically tighten all bolts, nuts and screws and check that all pins are properly installed to ensure unit is in a safe condition.

When completing a maintenance or service function, make sure all safety shields and devices are installed before placing machine in service.

SAFETY PRECAUTIONS

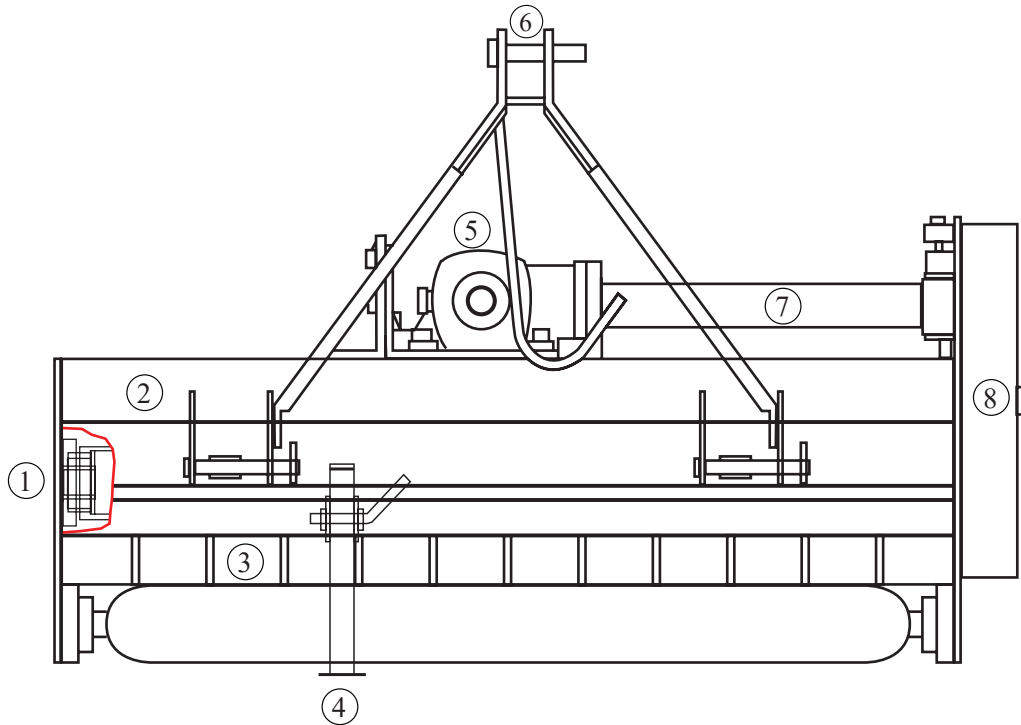

1. Blade axle	2. Blade axle cover	3. Combined fender
4. Stand	5. Gear box	6. Top Link Bracket
7. Transmission shaft		8. Belt & Pulley Cover

PTO Shaft



SAFETY & MODEL DECALS

The position of safety decals is shown in the illustration below. Good safety requires that you familiarize yourself with the various safety signs and increase your SAFETY AWARENESS.

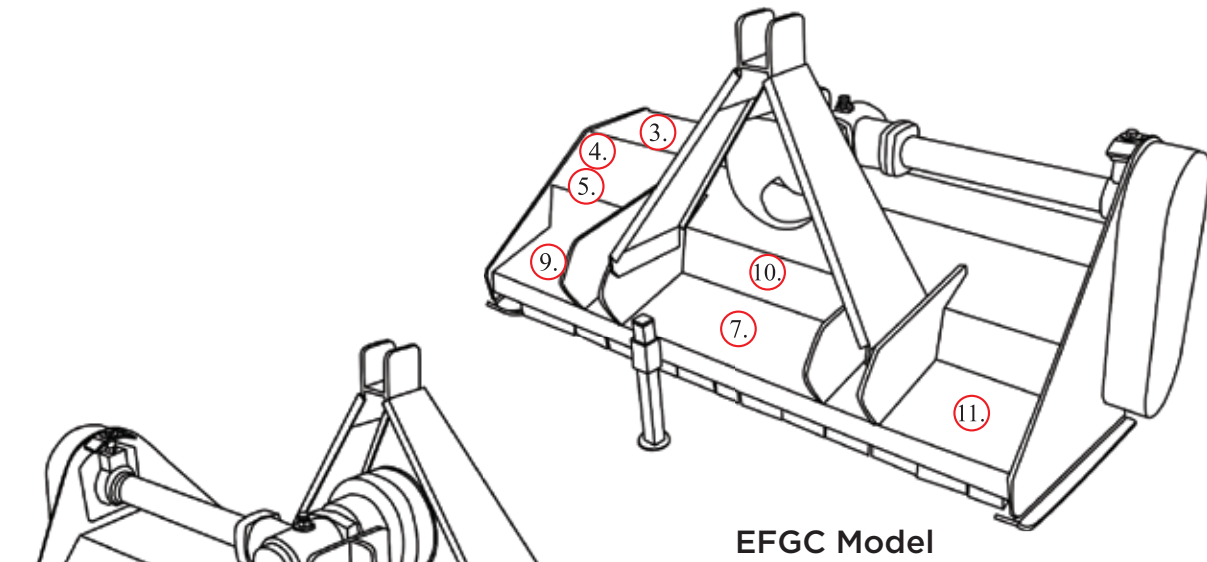

EFGC Model

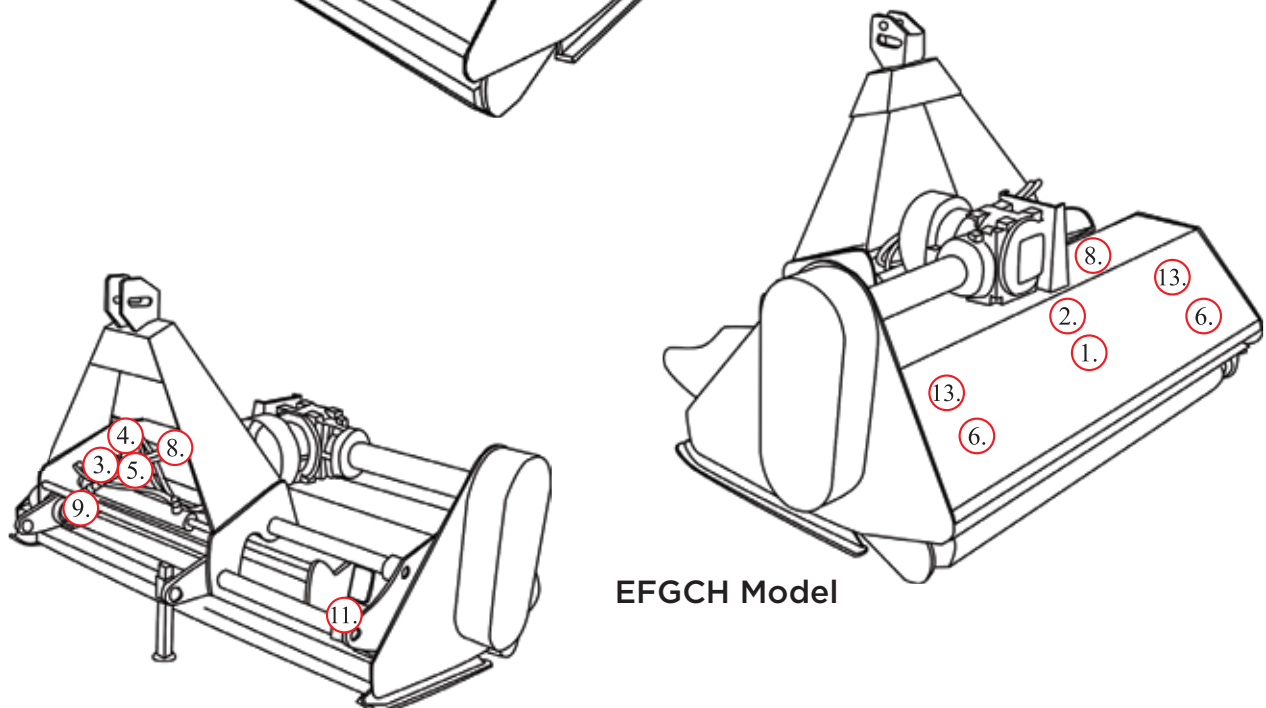

EFGCH Model

1.



2.

EFG-125

3.

		<input type="text"/>
Description/ Information		Model No.
Date	Country of Origin	
<input type="text"/>		
Serial No.		

4.

ST:

5.



6.



7.



8.



9.



10.



11.



12.



13.





PRODUCT SPECIFICATIONS



FLAIL MOWER MODELS:

EFGC - Flail Mower, Medium Duty

EFGCH - Hydraulic Side Shift Flail, Medium Duty

IMPLEMENT SPECIFICATIONS

MODELS	EFGC-105	EFGC-115	EFGC-125	EFGC-135	EFGC-145	EFGC-155	EFGC-165	EFGC-175
Tractor HP	18 - 25	18 - 25	25 - 30	25 - 30	25 - 30	30 - 40	30 - 40	30 - 40
3.P.L.	Cat 1	Cat 1	Cat 1	Cat 1	Cat 1	Cat 1	Cat 1	Cat 1
Length	1165	1265	1365	1485	1585	1685	1785	1885
Width	790	790	790	790	790	790	790	790
Height	845	845	845	845	845	845	845	845
Weight	170 kg	185 kg	200 kg	215 kg	230 kg	245 kg	260 kg	275 kg
Cutting Width	1015	1115	1215	1315	1415	1515	1615	1715
PTO	540 r/min	540 r/min	540 r/min	540 r/min	540 r/min	540 r/min	540 r/min	540 r/min
Gearbox HP	50 HP	50 HP	50 HP	50 HP	50 HP	50 HP	50 HP	50 HP
	16	20	20	24	24	24	28	28
	32	40	40	48	48	48	56	56

MODELS	EFGCH-105	EFGCH-115	EFGCH-125	EFGCH-135	EFGCH-145	EFGCH-155	EFGCH-165	EFGCH-175
Tractor HP	18 - 25	18 - 25	25 - 30	25 - 30	25 - 30	30 - 40	30 - 40	30 - 40
3.P.L.	Cat 1	Cat 1	Cat 1	Cat 1	Cat 1	Cat 1	Cat 1	Cat 1
Length	1165	1265	1365	1485	1585	1685	1785	1885
Width	1020	1020	1020	1020	1020	1020	1020	1020
Height	960	960	960	960	960	960	960	960
Weight	210 kg	225 kg	240 kg	255 kg	270 kg	285 kg	300 kg	315 kg
Cutting Width	1015	1115	1215	1315	1415	1515	1615	1715
PTO	540 r/min	540 r/min	540 r/min	540 r/min	540 r/min	540 r/min	540 r/min	540 r/min
Gearbox HP	50 HP	50 HP	50 HP	50 HP	50 HP	50 HP	50 HP	50 HP
	16	20	20	24	24	24	28	28
	32	40	40	48	48	48	56	56

Uses:

- Perfect for use after storms when debris is scattered throughout areas usually maintained with normal mowers
- Multi-purpose machines for mulching foliage and sticks
- Ideal for thick grass, sticks, undergrowth and light vine mulching
- Vegetable & pasture topping
- Roadside maintenance

Features:

- Cutting height controlled by adjustable skids
- High strength mulching blades
- Belt driven
- Safety flaps to prevent debris being thrown
- Extra strong and designed with safety in mind
- Support leg for storage
- Solid hitch

IDENTIFICATION OF THE IMPLEMENT

An identification plate is affixed to the frame of each implement. It contains the “CE” Certification brand and information about the Manufacturer, Model, Serial Number, Year of Manufacture and Weight.

CE Identification Plate



	<input type="text"/>
	Model No.
Description/ Information	
Date	Country of Origin
<input type="text"/>	
Serial No.	

CHECKING BEFORE OPERATING

Before operating the machine, the following areas should be checked off:

1. Before starting up the machine, check and lubricate all grease points on the machine and drive shaft.
2. Use only an agricultural tractor with horsepower within limits of the implement.
3. Check that the machine is properly attached to the tractor. Be sure retainers are used on the mounting pins.
4. Be sure extra weights are mounted on the front of the tractor, if required.
5. Check the oil level in the gearbox. Add as required.
6. Check that the tractor PTO shaft turns freely and that the machine driving shaft can telescope easily.
7. Check the blades. Be sure they are not damaged or broken and swing freely in their mount. Repair or replace as required
8. Check and tighten the blade bolts.
9. Check for entangled material in all rotating parts. Remove this material.
10. Install and secure all guards, doors and covers before starting.
11. Before installing the PTO, ensure the engine is stopped and the PTO shaft is in safe working order.

12. All other people shall leave the area before connecting the driving power from the tractor. Keep the output of the tractor at 540 RPM.
13. Before cleaning, repairing and lubricating the machine, stop the motor and take the key away with you.
14. When the PTO shaft is not connected with the tractor, support it through the frame to protect it from lying in the dirt.
15. Don't approach the machine when it is operating.

ADJUSTING THE HEIGHT

To get the most out of your flail mower, it should be set within the recommended height.

To save fuel, power and reduce the wear and tear, the cutting height must be regulated correctly.

When adjusting the working height, loosen screw (1), remove screw (2) on both sides;

The roller height (see following drawing) can be adjusted by aligning the selected hole in the roller support bracket at position 2. The lowest hole is the highest working height; put the screw (2) into the selected hole; tighten screw (1) and screw (2).

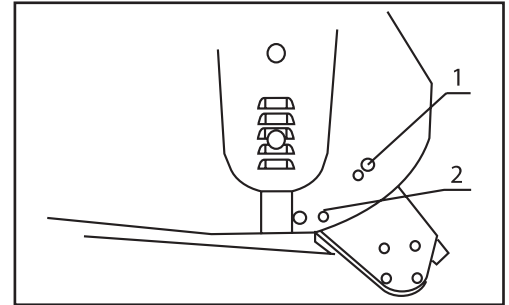

FLAIL MOWER ADJUSTMENT

1. On a flat piece of ground, attached the Flail Mower to the Tractor using the three point linkage.
 2. Use a solid adjustable top link.
 3. Lower three point linkage to its lowest position.
 4. With the roller at the rear in contact with the ground, adjust the length of the top link so that the lower edge at the side of the flail mower is parallel with the ground.
 5. Rotate the blade drum by hand so that a row of blades hang vertically towards the ground.
 6. Measure the clearance between the bottom of the extended blades and the ground:
 - Minimum 50mm
 - Note in rough or lumpy paddocks the clearance needs to be increased to ensure that the blades don't impact the ground in operation.
 7. Adjust the roller height to increase or decrease the blade clearance as required.
 8. Go through steps 4 to 7 until the required clearance is achieved.
- When the Flail Mower has been set up with the required tolerances:
Operate the Flail Mower with tractor in low range and the PTO delivering 540 RPM.

DRIVE BELT ADJUSTMENT

Loosen screw (A) and (B) that locks the support shaft and loosen the counter nut (C).

Loosen the screws that lock the gearbox on the mounting plate (D).

Adjust the drive belt tension. The correct belt tension is achieved when the belt can be deflected by the belt thickness about 10mm at the center point between the pulleys.

Align the gearbox so the drive shaft is parallel with the body.

Use a straight edge to make sure the belt pulleys are in-line and running true.

If mis-angled, call your dealer or service agent for technical support.

Fit safety covers and tighten the mounting bolts before operating.

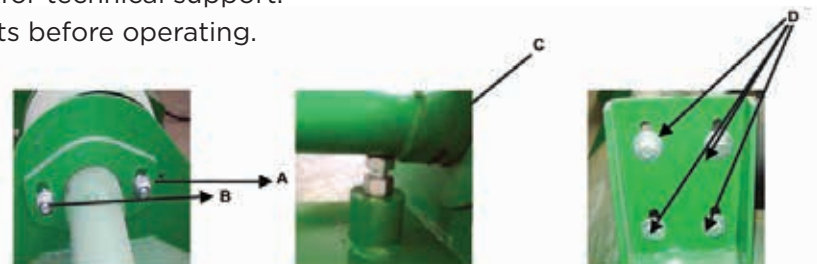



Approx.10mm deflection



Align with a Straight Edge

Before starting the machine, check and adjust the following items:

- Drive belt tension
- Gearbox oil level
- Grease nipples on bearing and PTO shaft
- All bolts, nuts and screws

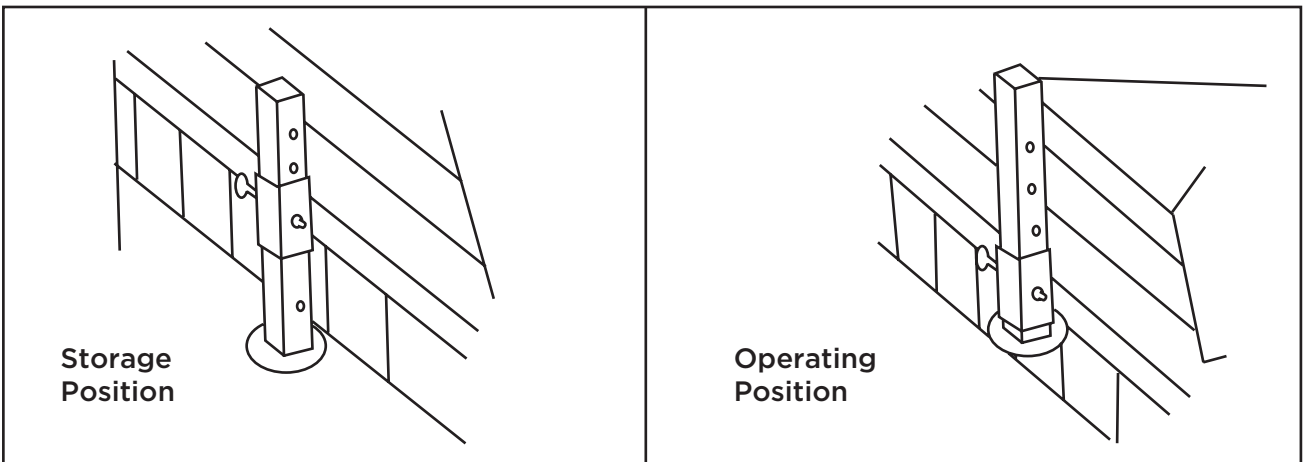

In order to keep the machine stable, lower the adjustment stand when the machine is stopped (see drawing above).

Follow all safety precaution detailed in this manual.

The machine is equipped with a standard category one, three point linkage.

Back the tractor into position in front of the flail mower. Lower the tractor hydraulic lift arms.

Turn the tractor off. Maneuver the implement by hand and attach the lower link arms to the lower link pin.

Ensure they are secured with lynch pin. Attach the top link to the top link bracket.

Adjust the lower link sway chains to allow minimal lateral movement. Attach the PTO shaft to the tractor PTO ensuring it has been cut to the required length.

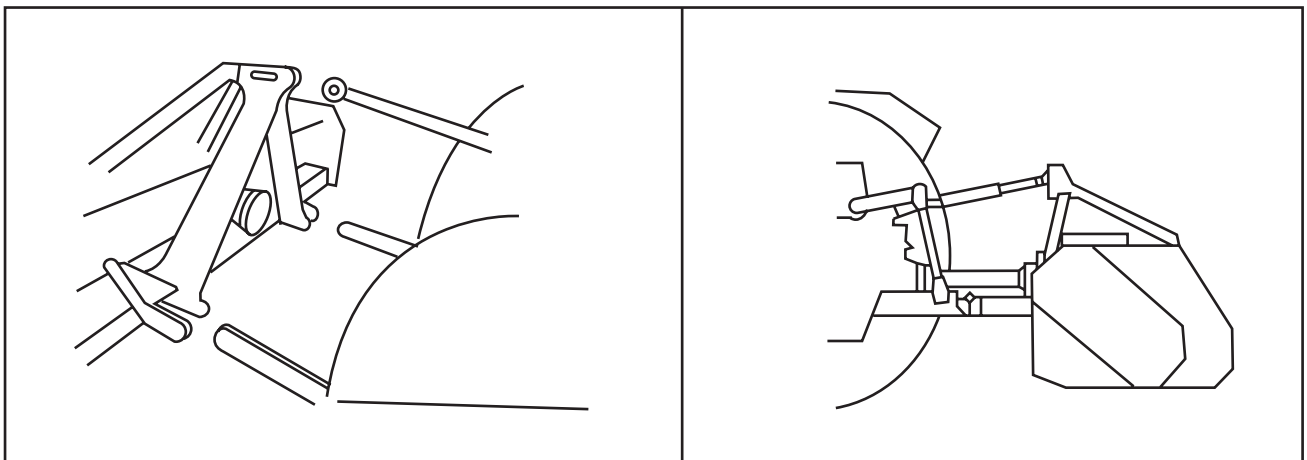

HYDRAULIC CONNECTION

In order to keep the machine stable, lower the adjustment stand when the machine is stopped (see drawing above).

Follow all safety precaution detailed in this manual.

The machine is equipped with a standard category one, three point linkage.

Back the tractor into position in front of the flail mower. Lower the tractor hydraulic lift arms.

Turn the tractor off. Maneuver the implement by hand and attach the lower link arms to the lower link pin.

Ensure they are secured with lynch pin. Attach the top link to the top link bracket.

Adjust the lower link sway chains to allow minimal lateral movement. Attach the PTO shaft to the tractor PTO ensuring it has been cut to the required length.

GREASING AND LUBRICATION

Each 4 hours of work:

- Check and tighten nuts and bolts
- Grease with lithium based grease when it is indicated by the symbol GREASE.

After 50 hr of work, check and fill the gearbox to the required level, using oil type SAE 90 EP API GL4 Oil.

Each 100 hr of work, check the gearbox oil level. Replace as required.



SERVICE & MAINTENANCE

Fluids and Lubricants

Grease:

- Use a multi-purpose lithium based grease.

Gearbox:

- Use SAE 90 gear oil.

Storing Lubricants:

Your machine can operate at top efficiency only if clean lubricants are used.

Use clean containers to handle all lubricants.

Store them in an area protected from dust, moisture and other contaminants.

Greasing

- Use a hand-held grease gun for all greasing.
- Wipe grease nipple with a clean cloth before greasing, to avoid injecting dirt and grit.
- Replace broken nipples immediately.

- If nipples will not take grease, remove and clean thoroughly. Also, clean lubricant passageway. Replace nipple if necessary.

MAINTENANCE

The period recommended is based on normal operating conditions. Severe or unusual conditions may require more frequent maintenance.

Hours or Daily Maintenance

- Check all nuts and bolts, tighten as required.
- Check the blade and blade bolts every day and replace the damaged parts.
Don't install damaged, worn and unbalanced blades. Replace sleeves as they become worn.

Note: The operator should put on gloves and use suitable tools before changing blade.

- Check the oil in gearbox. Fill up to line if necessary.
- Pump grease into each grease nipple three to five times.
- Clean the implement; remove grass and mud.

Season Maintenance

- Check the machine as in the terms of daily maintenance.
- Check the oil in gearbox; replace if it is contaminated.
- Check the blade spindles for wear and tear. If worn, disassemble, clean them and replace them, if necessary, grease as required.

Annual Maintenance

- Thoroughly clean mud and grass off the machine.
- Check and clean blade axles. Replace seals and grease as required.
- Check all blades, replace them if they are worn or damaged.
- Repair or replace the side skirts back to their original size and shape.
Replace damaged or broken protective devices.

The oil should be drained out and replaced after the first 50 hours of operation, then the oil should be changed every 250 hours, or at least once a year.

Drain oil from the gearbox thoroughly. Check and clean it. Fill with new gear oil up to the dedicated oil level.

The draining procedure is as follows:

Remove the draining bolt under the gearbox, so that the oil drains off.

After the oil is drained out, put the plug back and fill with gear oil up to the dedicated oil level.

	8hrs/ Daily			50hrs/Weekly			/Annually		
Lubricate PTO Shaft	✓			✓			✓		
Lubricate Caster Wheels	✓			✓			✓		
Lubricate Blade Spindle	✓			✓			✓		
Check Gear Box Oil Level				✓			✓		
Clean Machine							✓		
Lubricate and Clean PTO Shaft Cover							✓		

PTO SHAFT MAINTENANCE

The PTO shaft is designed to telescope to allow for dimensional changes as the machine goes through its operating range.

A Tubular guard encloses the driving components and is designed to turn relative to the driving components.

The shaft should telescope easily and the guard turn freely on the shaft at all times. Annual disassembly, cleaning and lubrication is recommended to ensure that all components function as intended.

To maintain the shaft, follow this procedure:

1. Remove the front of the machine
2. Pull shaft apart.
3. Use a screwdriver to pry the tabs out of the sleeves on each end.
4. Pull the shaft out of the plastic tubular guard.
5. Use a solvent to clean the male and female portions of the telescoping ends.
6. Apply a light coat of grease to each end.
7. Clean the grooves on each end where the tabs are located. Clean each tab also.
8. Apply a light coat of grease to each groove.
9. Insert the shaft into its respective guard and align the slots with the groove.
10. Insert the tabs through the slots and seat in the groove.
11. Check that each guard turns freely on the shaft.
12. Assemble the shaft.
13. Check that the shaft telescopes easily.
14. Replace any components that are damaged or worn.
15. Install the shaft on the machine.

GEARBOX MAINTENANCE

The gearbox used on the Flail Mower will give many years of trouble-free service with minimal maintenance requirements. Maintain the gearbox by following this procedure:

Oil Level:

- Remove the level plug from the rear or side of the gearbox.
- Add oil through the filler plug located on top of gearbox until oil comes out of the level plug.
- Add through the level plug if required.
- If gearbox has a dipstick on filler plug, then fill to indicator mark.

IMPORTANT: Check the oil level only when the unit is cold and the machine is on the level.

STORAGE

- Clean the machine inside and out, so as to avoid corrosion.
- Don't spray water on the rolling bearing if you clean the machine with high pressure sprayer.
- Check and clean the universal joint, driving belt press roller or replace them if they are not in good condition.
- Spread oil on all parts required.
- Re-coat the parts rubbed and damaged for anti corrosion.
- Store the machine in a dry, level area.

OPERATION & AFTER STORAGE

Before the machine is started back up, check the following items regularly:

- Check oil level and add if required.
- Check and tighten all screws and nuts.
- Check the blade condition. Replace as required.
- Check the air hole on the gearbox. If it is blocked, clean or open the hole with compressed air.
- Don't spread oil or grease on the driving belts. IF there is oil or grease on the belts, wipe the belts, to avoid slippage and premature wear.
- Check all moving parts and replace them if necessary.
- Check the protective cover are complete and operate correctly.

TROUBLESHOOTING GUIDE

PROBLEM	POSSIBLE CAUSE	POSSIBLE REMEDY
Excessive vibration of the machine.	Broken flails. Broken rotor support. Broken driving support shaft Bent rotor.	Replace Broken flail. Flails can be replaced by a competent operator. In other cases, replacement must be done by specialized staff. Replace rotor support with original parts. Replace shaft support with original parts. Replace rotor with original parts.
The grass is not cut.	Broken flails. Broken belts. Pulleys slipping on shafts. Broken gearbox.	Replace flails. For replacement of flails, adjustment or replacement belts and fixing lock joints, see paragraph relating to maintenance. Replace Belts. Fix pulley lock joints. Repair or replace gearbox.
Clogging of hammers/knives.	Rotor speed is too low.	Increase rotor speed.
Excessive wear of hammers/knives.	Rotor speed is too high.	Decrease rotor speed.
Flail mower vibrates during work.	Foreign matter stuck in between blades. Hammer/knives broken. Bolts of the rotor shaft support have come loose.	Remove foreign matter. Secure flail mower on a mechanical stand before maintaining blades or rotor. Replace hammer/knives. Lock bolts.

EXPLODED VIEW & PARTS LIST

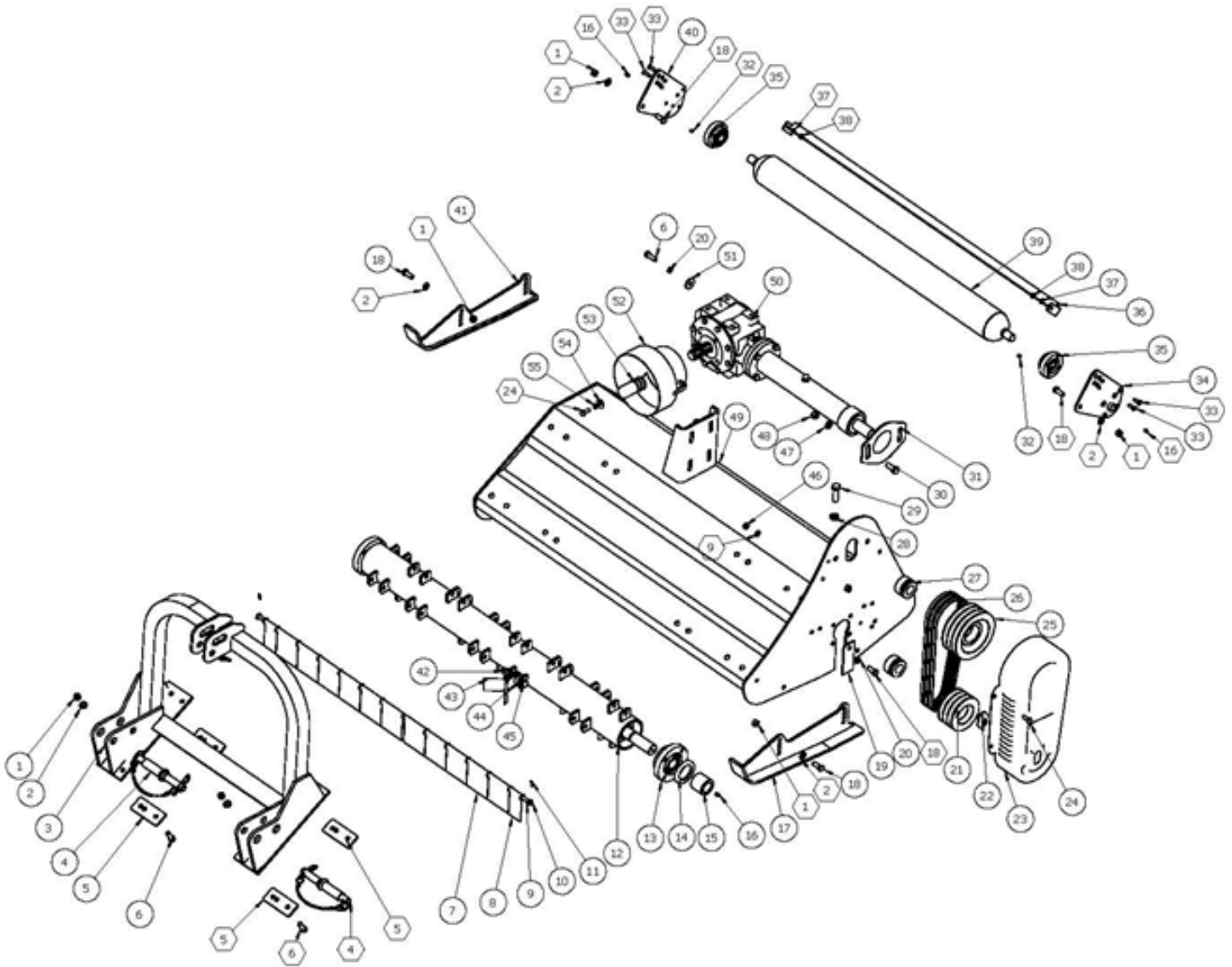

REF	PART NUM	DESCRIPTION	SPECIFICATION	QTY	
1	503010763	Nut	DIN985-M12	16	
2	506010057	Washer	GB971-12	25	
3-1	801680014	Suspension bracket EFGCM105-175	EFGCHM120.014B	1	105-175
3-2	801740006	Suspension bracket EFGCM200-220	EFGCHM200.014	1	200-220
4	802480066	(140-180Model) pin shaft	EFAG140.014	2	
5	701680001	Small plate	EFGCHM120.101	4	
6	501011127	Bolt	GB5783-M12X35	12	
7	700920107	Fender	EF100.00.121	1	
8	700920108	Fender	EF100.00.122	13	
9	506010056	Washer	GB971-10	22	
10-1	700940005	(105Model) fender shaft EFGCM105	EF100.00.123	1	
10-2	700950005	(115Model) fender shaft EFGCM115	EF110.00.123	1	
10-3	700960009	(125Model) fender shaft EFGCM125	EF120.00.123	1	
10-4	700970005	(135Model)fender shaft EFGCM135	EF130.00.123	1	
10-5	700980005	(145Model) fender shaft EFGCM145	EF140.00.123	1	
10-6	700990019	(155Model) fender shaft EFGCM155	EF150.00.123	1	
10-7	701000005	(165Model) fender shaft EFGCM165	EF160.00.123	1	
10-8	701010005	(175Model) fender shaft EFGCM175	EF170.00.123	1	

REF	PART NUM	DESCRIPTION	SPECIFICATION	QTY	
10-9	701010006	(200Model) fender shaft EFGCM200	EF200.00.123	1	
10-10	701010007	(220Model) fender shaft EFGCM220	EF220.00.123	1	
11	508011473	Pin shaft	GB879.1-4X25	2	
12-1	801140010	(105Model)(L=1003)blade axle EFGCM105	EFG100.013A	1	
12-2	801150010	(115Model)(L=1103) blade axle EFGCM115	EFG110.013A	1	
12-3	801160038	(125Model)(L=1203) blade axle EFGCM125	EFG120.013A	1	
12-4	801170010	(135Model)(L=1303) blade axle EFGCM135	EFG130.013A	1	
12-5	801180010	(145Model)(L=1403) blade axle EFGCM145	EFG140.013A	1	
12-6	801190010	(155Model)(L=1503) blade axle EFGCM155	EFG150.013A	1	
12-7	801200010	(165Model)(L=1603) blade axle EFGCM165	EFG160.013A	1	
12-8	801210010	(175Model)(L=1703) blade axle EFGCM175	EFG170.013A	1	
12-9	802080080	(200 Model) blade axle EFGCM200	EFG200.013A-G2	1	
12-10	802080085	(220Model) blade axle EFGCM220	EFG220.013A-G2	1	
13-1	511040032	Bearing	UC207	2	105-175
13-2	511040009	Bearing	UC208	2	200-220
14-1	510020417	Oil seal	GB13871-FB-55X80X8	1	105-175
14-2	510020397	Oil seal	CFW-60X85X8	1	200-220
15-1	705380014	(EFG105-175)(L=48) sleeve	RK120.109A	1	105-175
15-2	702080005	(EFG200-220)sleeve	G2-150.105	1	200-220
16	509010008	Oil cup	GB1152-M8X1	4	
17	801240022	Base plate	EFGC120.014	1	
18	501011126	Bolt	GB5783-M12X30	17	
19	701160033	Small plate	EFG120.103	1	
20	506030037	Washer	GB93-12	12	
21-1	701160006	Small pulley	EFG120.105A	1	
21-2	701160034	(EFGCM200 EFGCM220) small pulley	EFG120.105B	1	
22	701240046	U cover	EFGC120.138	1	105-175
23-1	701250006	(H=100) belt cover	EFGC120.111	1	200-220
23-2	706160004	(H=120) belt cover	EFGC200.111	1	
24	501011112	Bolt	GB5783-M10X25	4	
25-1	701160007	Big pulley	EFG120.106A	1	105-175
25-2	701160040	(EFGCM200) big pulley	EFG120.106B	1	200-220
26	514010001	Belt	17X991	3	
27-1	515010001	Sleeve	REACH04-35X60	2	105-175
27-2	515010007	Sleeve	REACH04-40X65	2	200-220
28	503010137	Nut	GB6173-M16X1.5	1	
29	501011905	Bolt	GB5786-M16X1.5X50	1	
30	501011141	Bolt	GB5783-M14X35	2	
31-1	701240007	Lath	EFGC120.102A	1	105-175
31-2	706160003	Lath	EFGC200.102	1	200-220
32	509010007	Oil cup	GB1152-M6	2	
33	501030185	Bolt	GB70.3-M8X25	10	
34	801160004	Roller supporting	EFG120.018	1	
35	511040007	UC205 bearing	EF100.00.012	2	
36-1	801140008	(105Model)(L=1040) mud shield	EFG100.024	1	
36-2	801150008	(115Model)(L=1140) mud shield	EFG110.024	1	
36-3	801160030	(125Model)(L=1240) mud shield	EFG120.024	1	
36-4	801170008	(135Model)(L=1340) mud shield	EFG130.024	1	

REF	PART NUM	DESCRIPTION	SPECIFICATION	QTY
36-5	801180008	(145Model)(L=1440) mud shield	EFG140.024	1
36-6	801190008	(155Model)(L=1540) mud shield	EFG150.024	1
36-7	801200008	(165Model)(L=1640) mud shield	EFG160.024	1
36-8	801210008	(175Model)(L=1740) mud shield	EFG170.024	1
36-9	801130012	(200Model)(L=1990) mud shield	EFG200.024	1
36-10	801130013	(220Model)(L=2190) mud shield	EFG220.024	1
37	506010055	Washer	GB97.1-8	2
38	503010761	Nut	DIN985-M8	2
39-1	801140004	(105Model)(L=1027) roller	EFG100.012	1
39-2	801150004	(115Model)(L=1127) roller	EFG110.012	1
39-3	801160017	(125Model)(L=1227) roller	EFG120.012	1
39-4	801170004	(135Model)(L=1327) roller	EFG130.012	1
39-5	801180004	(145Model)(L=1427) roller	EFG140.012	1
39-6	801190004	(155Model)(L=1527) roller	EFG150.012	1
39-7	801200004	(165Model)(L=1627) roller	EFG160.012	1
39-8	801210004	(175Model)(L=1727) roller	EFG170.012	1
39-9	801160036	(200Model)(L=1977) roller	EFG200.012	1
39-10	801160041	(220Model)(L=2177)roller	EFG220.012	1
40	801160001	Roller supporting	EFG120.017	1
41	801240019	Left base	EFGC120.013	1
42	503010740	Nut	DIN985-M16X1.5	20
43	701240009	(Y) blade	EFGC120.104	20
44	701240008	Sleeve	EFGC120.103	20
45	501014730	Bolt	ZDLS-M16X1.5X85	20
46	503010762	Nut	DIN985-M10	2
47	506010058	Washer	GB97.1-14	2
48	503010764	Nut	DIN985-M14	2
49-1	801680030	(105Model) hood	EFGCHM100.011B	1
49-2	801680031	(115Model) hood	EFGCHM110.011B	1
49-3	801680024	(125Model) hood	EFGCHM120.011B	1
49-4	801690024	(135Model) hood	EFGCHM130.011B	1
49-5	801700024	(145Model) hood	EFGCHM140.011B	1
49-6	801710024	(155Model) hood	EFGCHM150.011B	1
49-7	801720024	(165Model) hood	EFGCHM160.011B	1
49-8	801730024	(175Model) hood	EFGCHM170.011B	1
49-9	801740001	(200Model) hood	EFGCHM200.011A	1
49-10	801750001	(220Model) hood	EFGCHM220.011A	1
50-1	801240026	(105Model) gearbox with shaft	EFGC100.015	1
50-2	801240023	(125Model) gearbox with shaft	EFGC120.015	1
50-3	801240027	(135Model) gearbox with shaft	EFGC130.015	1
50-4	802520119	(200/220/250Model) gearbox with shaft	EFGCH200.021A	1
51	506010037	Washer	GB96.1-12	4
52	703400008	PTO cover	FM120.00.199	1
53	702420030	Shaft cover	EF100.00.177	1
54	506010036	Washer	GB96.1-10	4
55	506030036	Spring washer	GB93-10	4

GEARBOX ASSEMBLY

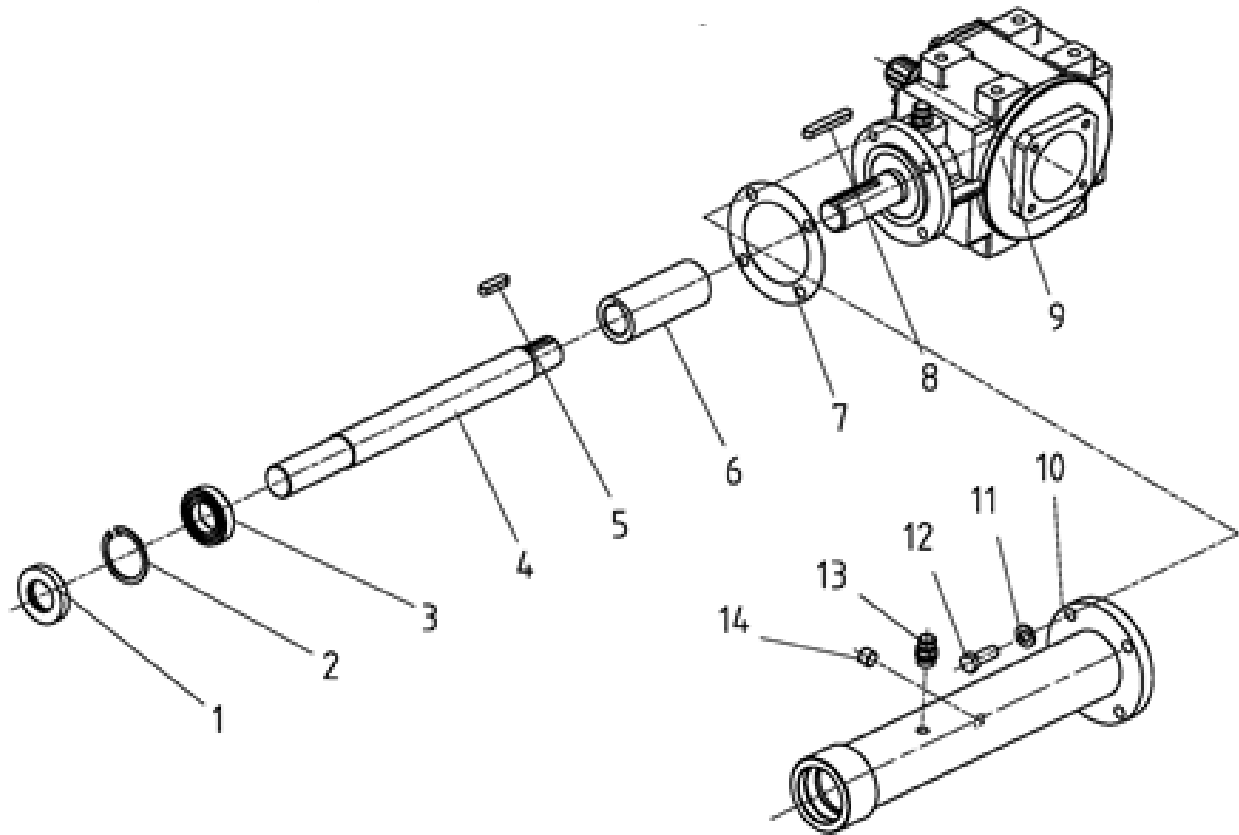

REF	PART NUM	DESCRIPTION	SPECIFICATION	QTY
1-1	510020640	GB13871-FB-35X72X12	FB35X72X12 oil seal	1
1-2	510020405	GB13871-FB-40X80X10	FB40X80X10 oil seal (200,220)	1
2-1	506060188	GB893.1-72	72 cir clip	1
2-2	506060191	GB893.1-80	80 cir clip (200,220)	1
3-1	511021666	GB276-6207-2Z	6207 bearing	1
3-2	511021529	GB276-6208-2Z	6208 bearing (200,220)	1
4-1	701220003	EFGC100.133A	(EFGC105-115Model) shaft	1
4-2	701240003	EFGC120.133A	(EFGC125Model) shaft	1
4-3	701250003	EFGC130.133A	(EFGC135-175Model) shaft	1
4-4	701600034	EFGCH200.166B	(EFGCHZ/M/H-200)(L=638) shaft	1
5	507010086	GB1096-A-10X8X40	A10X40 key	1
6	701240025	EFGC120.132	Sleeve	1
7	701240024	EFGC120.131	Gasket	1
8	507010091	GB1096-A-10X8X70	A10X70 key	1
9-1	801240040	XH50.300Z.02	Gearbox	1
9-2	801380003	XH50.300Z.02-200	(EFGCM200) gear box	1
10-1	801220004	EFGC100.018A	(EFGC100-110) shaft cover	1
10-2	801240004	EFGC120.018A	(EFGC120-170) shaft cover	1
10-3	801600032	EFGCH200.026A	(EFGCHZ/M/H-200)(L=640) shaft cover	1
11	506030037	GB93-12	12 washer	4
12	505011445	GB70.1-M12X35	M12X35 bolt	4
13	705290211	CBW-00-011B	Breath plug	1
14	516010003	ZBT32001.3-ZG3/8-19"	ZG3/8"-19 tapered plug	1

BLADE AXLE SUBASSEMBLY (EFGC105-175)

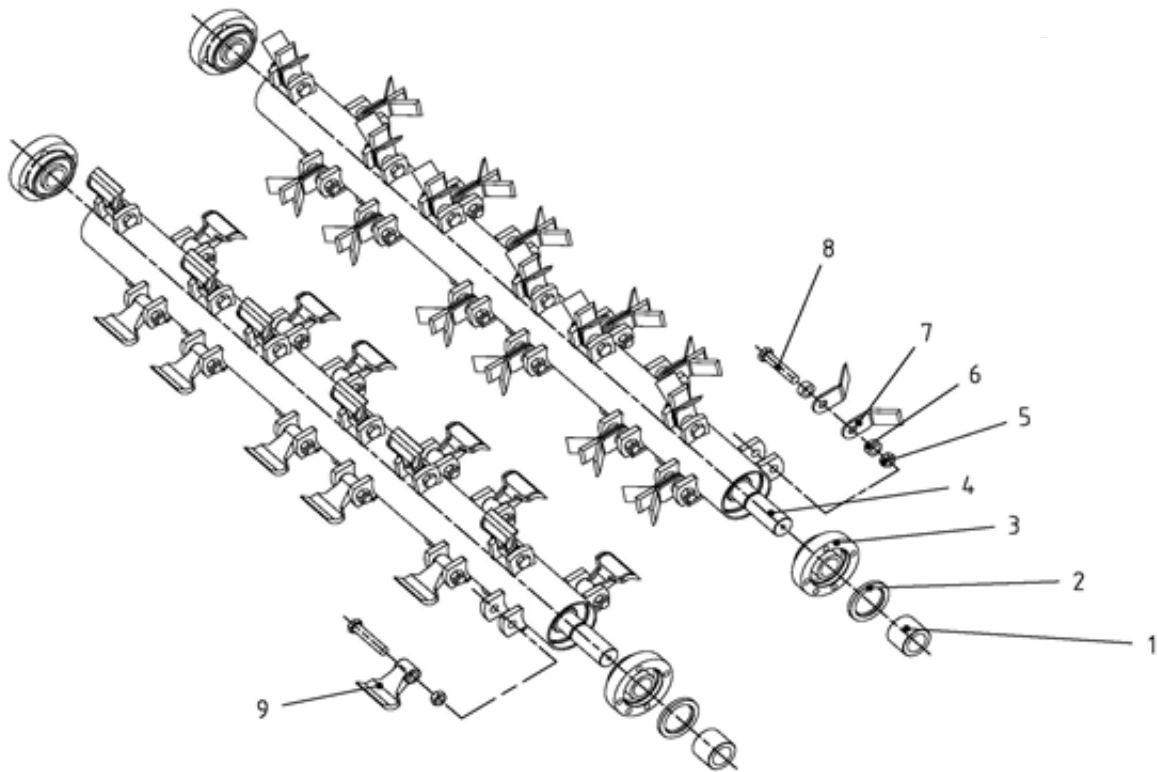

REF	PART NUM	DESCRIPTION	SPECIFICATION	QTY
1	705380014	RK120.109A	Oil seal cover	1
2	510020417	GB13871-FB-55X80X8	FB55X80X8 oil seal	1
3	511040032	UC207	Bearing seat 90207	2
4-1	801140010	EFG100.013A	Blade shaft 100	1
4-2	801150010	EFG110.013A	Blade shaft 110	1
4-3	801160038	EFG120.013A	Blade shaft 120	1
4-4	801170010	EFG130.013A	Blade shaft 130	1
4-5	801180010	EFG140.013A	Blade shaft 140	1
4-6	801190010	EFG150.013A	Blade shaft 150	1
4-7	801200010	EFG160.013A	Blade shaft 160	1
4-8	801210010	EFG170.013A	Blade shaft 170	1
5	503010740	DIN985-M16X1.5	M16X1.5 lock nut	20
6	701240008	EFGC120.103	Spacer bush	40
7	701240009	EFGC120.104	Y blade	40
8	501014730	EFGC120.200A	M16X1.5X85 bolt	20
9	701240010	EFGC120.104A	Hammer	20

BLADE AXLE SUBASSEMBLY (EFGC200-220)

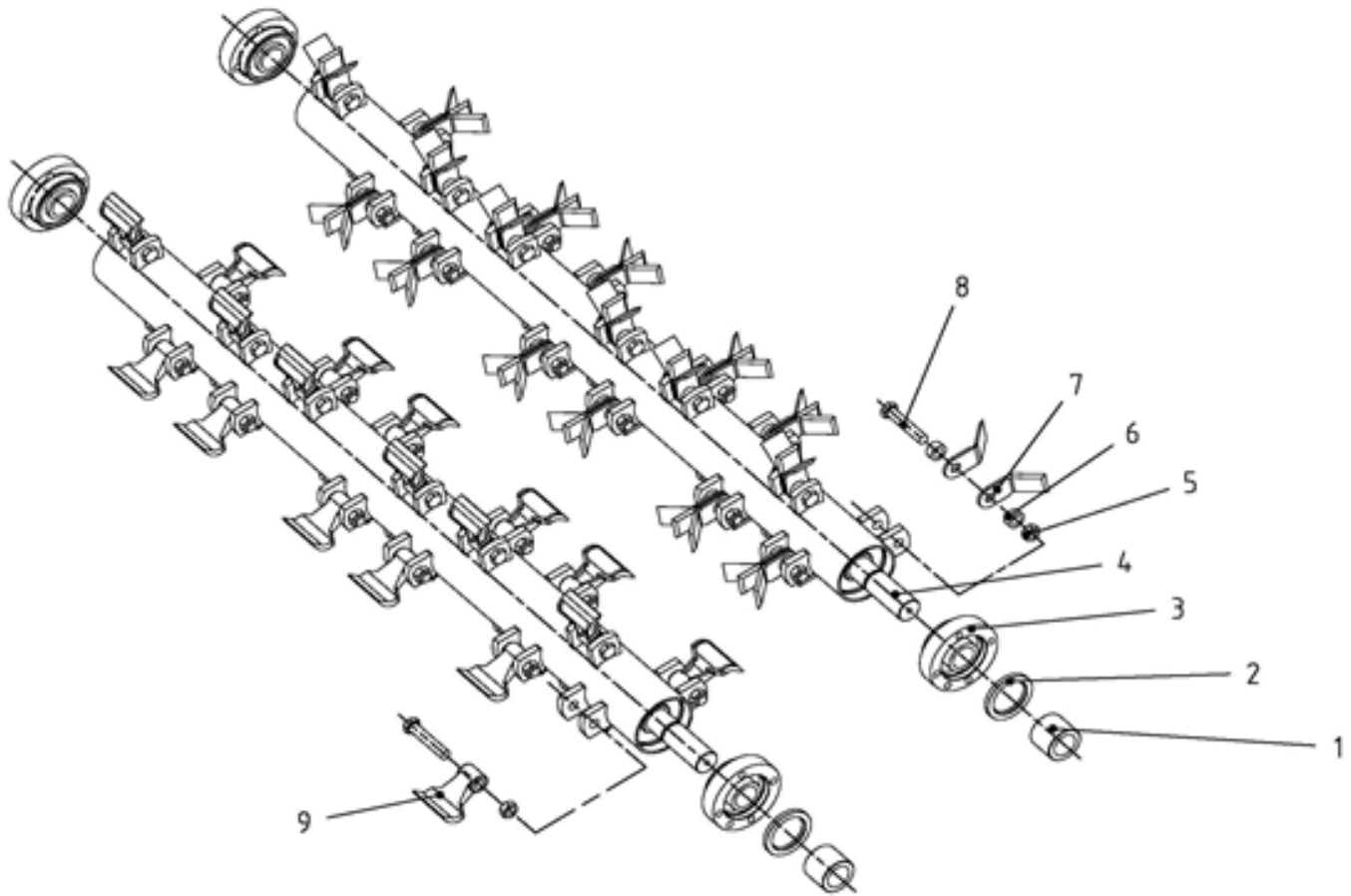

REF	PART NUM	DESCRIPTION	SPECIFICATION	QTY
1	702080005	G2-150.105	oil seal cover	1
2	510020397	CFW-60X85X8	FB60X85X8 oil seal	1
3	511040009	UC208	Bearing seat 90208	2
4-1	802080080	EFG200.013A-G2	Blade shaft 200	1
4-2	802080085	EFG220.013A-G2	Blade shaft 220	1
5	503010740	DIN985-M16X1.5	M16X1.5 Lock Nut	20
6	701240008	EFGC120.103	Spacer bush	40
7	701240009	EFGC120.104	Y blade	40
8	501014730	EFGC120.200A	M16X1.5X85 Bolt	20
9	701240010	EFGC120.104A	Hammer	20

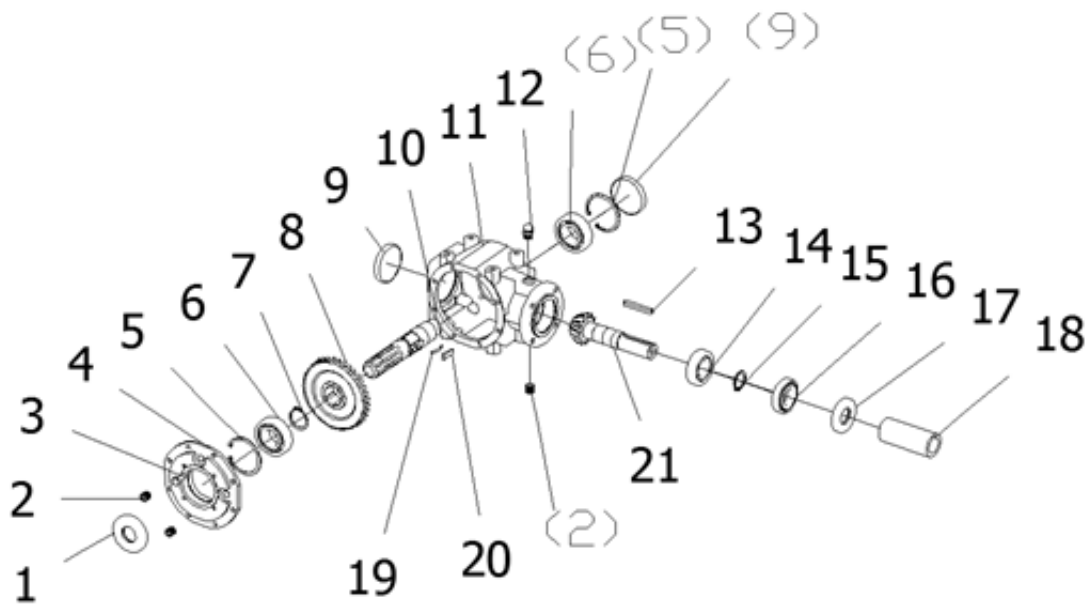

REF	PART NUM	DESCRIPTION	SPECIFICATION	QTY	
1	510020638	GB13871-FB-35x80x10	FB oil seal	1	
2	516010003	ZBT32001.3-ZG3/8-19"	hexagon socket tapered plug	3	
3	501011112	GB5783-M10x25	Screw bolt	8	
4	702480003	AG14.01.C03	311 shell cap	1	
5	506060191	GB893.1-80	A check ring	2	
6	511022654	GB276-6307	Deep groove ball bearing	2	
7	506060322	GB894.1-42	A shaft check ring	1	
8	702480005	AG14.01.C05	driving gear	1	EFGCMZ105-175
8(1)	702080002	AG14.01.C05-G2	driving gear	1	EFGCMZ200-220
9	703340013	NFG-RCA-80X10	80X10 blanking cap	2	
10	701240041	GC175.01.C04A	input shaft	1	
11	702480003	AG14.01.C03	311 shell cap	1	
12	705290211	CBW-00-011B	ZG3/8 Air plug screw	1	
13	507010091	GB1096-A-10X8X70	A flat key	1	
14	511016440	GB297-32207	Tapered roller bearing	1	
15	506060515	JB4342-35	Check ring	1	
16	511016411	GB297-30207	Tapered roller bearing	1	
17	510020398	CFW-35X72X10	FB oil seal	1	
18	701240025	EFGC120.132	Connecting sleeve	1	
19	702480007	AG14.01.C07	leaf spring	1	
20	702480006	AG14.01.C06	key	3	
	702480001	AG14.01.C01	output shaft gear	1	EFGCMZ105-175
21(1)	702080001	AG14.01.C01-G2	output shaft gear	1	EFGCMZ200-220



BRABEREQ.COM
WGSALES@BRABEREQ.COM

PHONE: 604-850-7770
FAX: 604-850-7774
TOLL FREE PHONE: 1-877-588-3311
TOLL FREE FAX: 1-800-665-7334