



1" Air-Operated Double Diaphragm Pump

24 GPM

Owner's Manual



⚠ WARNING: Read carefully and understand all ASSEMBLY AND OPERATION INSTRUCTIONS before operating. Failure to follow the safety rules and other basic safety precautions may result in serious personal injury.

Item #70636

READ & SAVE THESE INSTRUCTIONS

Thank you very much for choosing a Roughneck™ product!

For future reference, please complete the owner's record below:

Serial Number/Lot Date Code: _____

Purchase Date: _____

Save the receipt, warranty, and this manual. It is important that you read the entire manual to become familiar with this product before you begin using it.

This pump is designed for certain applications only. Northern Tool and Equipment is not responsible for issues arising from modification or improper use of this product such as an application for which it was not designed. We strongly recommend that this product not be modified and/or used for any application other than that for which it was designed.

For technical questions, please call **1-800-222-5381**.

Table of Contents

Intended Use.....	4
Packaging Contents.....	4
Technical Specifications	4
Important Safety Information	4
Specific Operation Warnings	6
Main Parts of Pump.....	8
Assembly Instructions.....	9
Before Each Use.....	13
Operating Instructions.....	13
Maintenance	16
Troubleshooting	17
Parts Diagram	18
Parts List	19
Replacement Parts	20
Limited Warranty	21

Intended Use

The Roughneck 1" Air-Operated Double Diaphragm Pump offers high volume delivery even at low air pressure. The air-operated double diaphragm pump uses a pressure differential in the air chambers to alternately create suction and positive fluid pressure in the fluid chambers. The ball check insures a positive flow of fluid.

Packaging Contents

- Hex- Bolt M8*65 (8)
- Discharge Manifold (2)
- Valve Cover (2)
- Valve Ball (4)
- Valve Seat (4)
- O-ring 1.49" * 0.1" (4)
- Hex Bolt M8 * 25 (16)
- Hex Bolt M12*25 (2)
- O-ring 0.68" *0.07" (2)
- Liquid Chamber Plate (2)
- Diaphragm (2)
- Air Chamber Plate (2)
- Screw M8 *16 (12)
- Air Chamber (2)
- Brackets (2)
- M4*6 Screw
- Air Motor Assembly (1)
- Nut (16)
- O-ring 3.74" *0.1" (2)
- Plug (2)
- Pump Cover (2)

Technical Specifications

Property	Specification
Inlet/Outlet	1"
Air Inlet	1/4"
Flow Rate	24 GPM
Max. Air Inlet Pressure	115 PSI
Max. Outlet Pressure	115 PSI
Max. Diameter Solid	1/8"
Membrane	Nitrile
Compatibility	Oil, Diesel, Grease, and Kerosene

Important Safety Information

⚠WARNING

- Read and understand all instructions. Failure to follow all instructions may result in serious injury or property damage.
- The warnings, cautions, and instructions in this manual cannot cover all possible conditions or situations that could occur. Exercise common sense and caution when using this tool. Always be aware of the environment and ensure that the tool is used in a safe and responsible manner.
- Do not allow persons to operate or assemble the product until they have read this manual and have developed a thorough understanding of how it works.

- Do not modify this product in any way. Unauthorized modification may impair the function and/or safety and could affect the life of the product. There are specific applications for which the product was designed.
- Use the right tool for the job. DO NOT attempt to force small equipment to do the work of larger industrial equipment. There are certain applications for which this equipment was designed. This product will be safer and do a better job at the capacity for which it was intended. DO NOT use this equipment for a purpose for which it was not intended.
- Industrial or commercial applications must follow OSHA requirements.

⚠WARNING

WORK AREA SAFETY

- Inspect the work area before each use. Keep work area clean, dry, free of clutter, and well-lit. Cluttered, wet, or dark work areas can result in injury. Using the product in confined work areas may put you dangerously close to cutting tools and rotating parts.
- Do not use the product where there is a risk of causing a fire or an explosion; e.g., in the presence of flammable liquids, gases, or dust. The product can create sparks, which may ignite the flammable liquids, gases, or dust.
- Do not allow the product to come into contact with an electrical source. The tool is not insulated and contact will cause electrical shock.
- Keep children and bystanders away from the work area while operating the tool. Do not allow children to handle the product.
- Be aware of all power lines, electrical circuits, water pipes, and other mechanical hazards in your work area. Some of these hazards may be hidden from your view and may cause personal injury and/or property damage if contacted.

⚠WARNING

PERSONAL SAFETY

- Stay alert, watch what you are doing, and use common sense when operating the tool. Do not use the tool while you are tired or under the influence of drugs, alcohol, or medication. A moment of inattention while operating the tool may result in serious personal injury.
- Dress properly. Do not wear loose clothing, dangling objects, or jewelry. Keep your hair, clothing and gloves away from moving parts. Loose clothes, jewelry, or long hair can be caught in moving parts. Air vents on the tool often cover moving parts and should be avoided.
- Wear the proper personal protective equipment when necessary. Use ANSI Z87.1 compliant safety goggles (not safety glasses) with side shields, or when needed, a face shield. Use a dust mask in dusty work conditions. Also use non-skid safety shoes, hardhat, gloves, dust collection systems, and hearing protection when appropriate. This applies to all persons in the work area.
- Do not overreach. Keep proper footing and balance at all times.
- Remove keys or wrenches before connecting the tool to an air supply, power supply, or turning on the tool. A wrench or key that is left attached to a rotating part of the tool may cause personal injury.

⚠CAUTION

PUMP USE AND CARE

- Do not force the pump. Products are safer and do a better job when used in the manner for which they are designed. Plan your work, and use the correct product for the job.
- Check for damaged parts before each use. Carefully check that the product will operate properly and perform its intended function. Replace damaged or worn parts immediately. Never operate the product with a damaged part.
- Do not use a product with a malfunctioning switch. Any power tool that cannot be controlled with the power switch is dangerous and must be repaired by an authorized service representative before using.
- Disconnect the power/air supply from the product and place the switch in the locked or off position before making any adjustments, changing accessories, or storing the tool. Such preventive safety measures reduce the risk of starting the tool accidentally.
- Store the product when it is not in use. Store it in a dry, secure place out of the reach of children. Inspect the tool for good working condition prior to storage and before re-use.
- Use only accessories that are recommended by the manufacturer for use with your product. Accessories that may be suitable for one product may create a risk of injury when used with another tool. Never use an accessory that has a lower operating speed or operating pressure than the tool itself.
- Keep guards in place and in working order. Never operate the product without the guards in place.
- Do not leave the tool running unattended.

Specific Operation Warnings

⚠WARNING

- Do not exceed the maximum inlet air pressure of 115 PSI.
- Be sure material hoses and other components are able to withstand fluid pressures developed by this pump. Check all hoses for damage or wear. Be certain dispensing device is clean and in proper working condition.
- Static Spark Hazard. Sparks from static electricity can ignite flammable materials and vapors, causing explosion resulting in severe injury or death. Ground pump and pumping system.
- The pumping system and object being sprayed must be grounded when it is pumping, flushing, recirculating or spraying flammable materials such as paints, solvents, lacquers etc. or used in a location where surrounding atmosphere is conducive to spontaneous combustion. Ground the dispensing valve or device, containers, hoses and any object to which material is being pumped.
- Use the pump grounding screw terminal provided. Connect a suitable ground wire to a good earth ground source.
- EXPLOSION HAZARD. Models containing aluminum wetted parts cannot be used with III.- Trichloroethane, Methylene Chloride or other Halogenated Hydrocarbon solvents which may react and explode.

- Consult local building codes and electrical codes for specific grounding requirements.
- After grounding, periodically verify continuity of electrical path to ground. Test with an ohmmeter from each component (e.g., hoses, pump, clamps, container, spray gun) to ground to insure continuity. Ohmmeter should show 100 ohms or less.
- Pump exhaust may contain contaminants which can cause severe injury. Pipe exhaust away from work area and personnel.
- In the event of a diaphragm rupture material can be forced out of the air exhaust muffler.
- Pipe the exhaust to a safe remote location when pumping hazardous or inflammable materials.
- Do not use a chemical that is not compatible with this pump.
- Inspect before each use. Before switching the air supply on, check hoses for any sign of wear, leaks, or loose fittings. Replace as necessary.
- Secure pump, connections and all contact points to avoid vibration and generation of contact or static spark.
- Do not use the pump for the structural support of the piping system. Be certain the system components are properly supported to prevent stress on the pump parts.
- Prevent unnecessary damage to the pump. Do not allow pump to operate when out of material for long periods of time.
- Disconnect air line from pump when system sits idle for long periods of time.
- Use proper ventilation.
- Keep flammables away from heat, open flames and sparks.
- Keep containers closed when not in use.

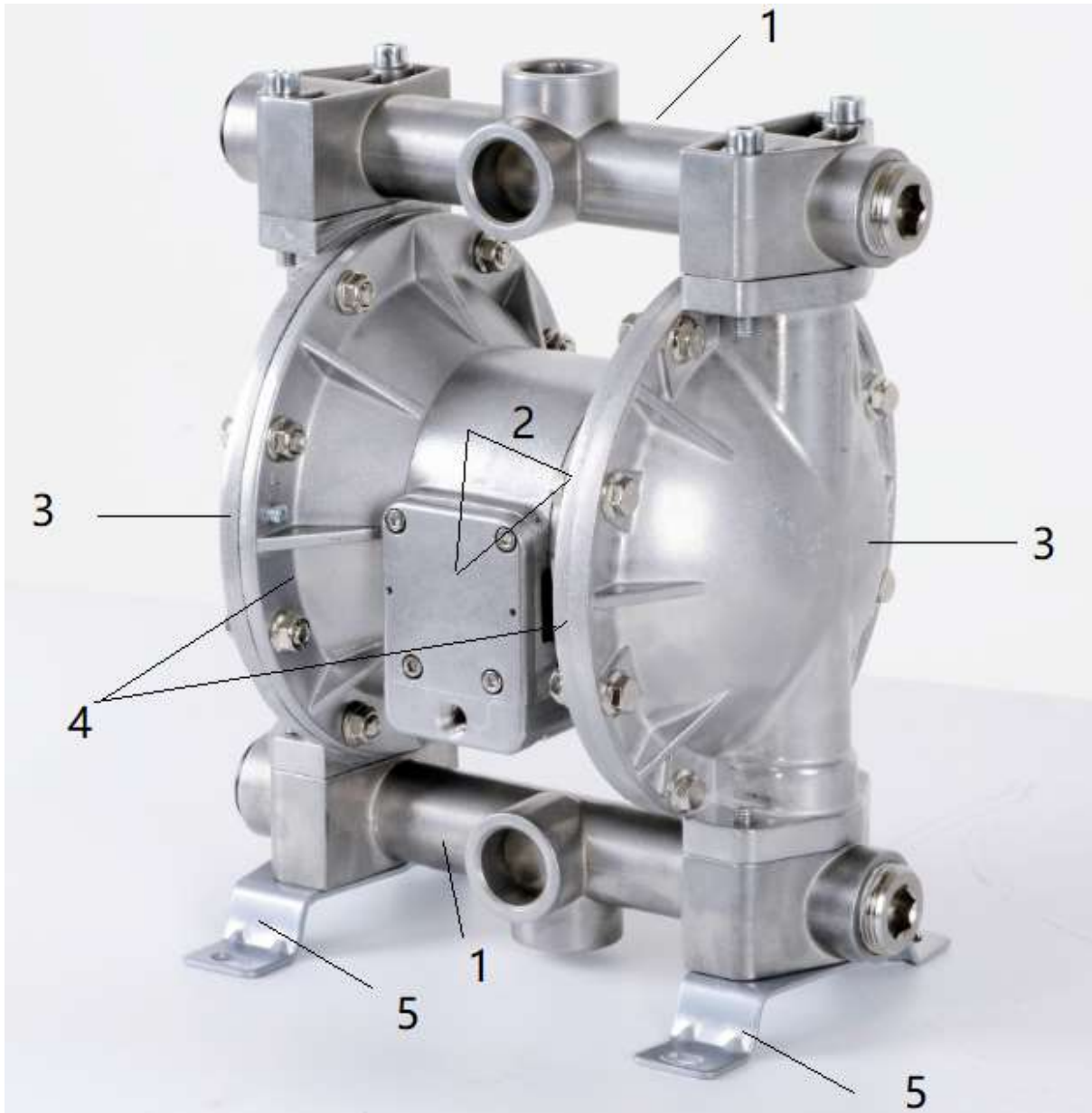

Main Parts of Pump

Part Number	Part Description	Quantity
1	Discharge Manifold	2
2	Air Motor Assembly	1
3	Pump Cover	2
4	Air Chamber	2
5	Bracket	2

Assembly Instructions

The Air Motor Assembly (#17) should only be disassembled by a technician. The following image is of the pump fully assembled.



1. Use six of the M8 *16 Screws (#13) to attach the Air Chamber (#14) to the Air Motor Assembly (#17).





2. Assemble the Diaphragm (#11) using the Hex Bolt (#8) and O-ring (#9) to attach the Liquid Chamber Plate (#10) and Air Chamber Plate (#12).

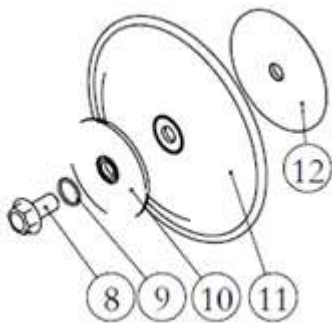



3. Tighten the Pump Cover (#21) using eight of the Hex Bolts (#7).



4. Assemble the Discharge Manifold (#2) using four of the Hex Bolts (#1).





5. Place the other #2 Discharge Manifold on the top and tighten it using 4 of the Hex Bolts (#1). Insert two of the Plugs (#20) into the left and right holes of the Discharge Manifold (#2).



6. The assembly is now complete.



Before Each Use

⚠WARNING

- Inspect before each use. Before switching the air supply on, check hoses for any sign of wear, leaks, or loose fittings. Replace as necessary.
- Secure pump, connections and all contact points to avoid vibration and generation of contact or static spark.
- Pipe the exhaust to a safe remote location when pumping hazardous or inflammable materials.
- Do not use a chemical that is not compatible with this pump.
- Prevent unnecessary damage to the pump. Do not allow pump to operate when out of material for long periods of time.

Operating Instructions

⚠WARNING

- Do not exceed the maximum inlet air pressure of 115 PSI.
- Be sure material hoses and other components are able to withstand fluid pressures developed by this pump. Check all hoses for damage or wear. Be certain dispensing device is clean and in proper working condition.
- Static Spark Hazard. Sparks from static electricity can ignite flammable materials and vapors, causing explosion resulting in severe injury or death. Ground pump and pumping system.
- The pumping system and object being sprayed must be grounded when it is pumping, flushing, recirculating or spraying flammable materials such as paints, solvents, lacquers etc. or used in a location where surrounding atmosphere is conducive to spontaneous combustion. Ground the dispensing valve or device, containers, hoses and any object to which material is being pumped.
- Use the pump grounding screw terminal provided. Connect a suitable ground wire to a good earth ground source.
- EXPLOSION HAZARD. Models containing aluminum wetted parts cannot be used with III.- Trichloroethane, Methylene Chloride or other Halogenated Hydrocarbon solvents which may react and explode.
- Consult local building codes and electrical codes for specific grounding requirements.
- After grounding, periodically verify continuity of electrical path to ground. Test with an ohmmeter from each component (e.g., hoses, pump, clamps, container, spray gun, etc.) to ground to insure continuity. Ohmmeter should show 100 ohms or less.
- In the event of a diaphragm rupture material can be forced out of the air exhaust muffler.
- Do not use the pump for the structural support of the piping system. Be certain the system components are properly supported to prevent stress on the pump parts.
- Disconnect air line from pump when system sits idle for long periods of time.
- Use proper ventilation.

- Keep flammables away from heat, open flames and sparks.
- Keep containers closed when not in use.

Before Operating

- A filter capable of filtering out particles larger than 50 microns should be used on the air supply. There is no lubrication required other than the O-ring lubricant which is applied during assembly or repair.
- If lubricated air is present, make sure that it is compatible with the O-rings in the air motor section of the pump.
- If there is any remaining material in the pump, flush the remaining material with the existing solvent before pumping new material.
- Disconnect the air supply from the pump if it is to be inactive for a few hours.
- Disconnect the air supply from the pump if it is not in use.
- The material supply tubing should not be too small or restrictive. Be sure not to use hose that may collapse.
- When the diaphragm pump is used in a forced-feed (flooded inlet) situation, it is recommended that a check valve be installed at the air inlet.
- Secure the diaphragm pump legs to a suitable surface to insure against damage by vibration.

Operating the Pump

1. Connect the hose to the pump outlet port which is on top side of the pump. (The hose and hose clamp are not provided.)



2. Connect the hose to the pump inlet port which is at the bottom side of the pump.

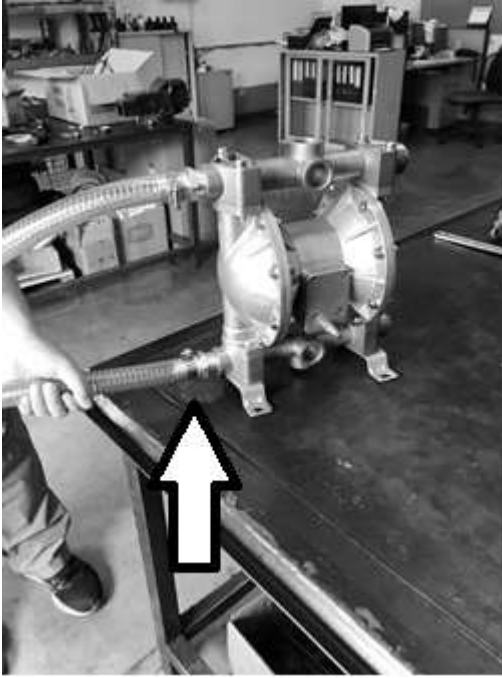

3. Connect the air inlet to the pump. The air pressure range is from 44 PSI to 115 PSI. Do not exceed.



4. Place the inlet hose into the working container and put the outlet hose into another container. The pump is now ready for operating.



Maintenance

1. Provide a clean work surface to protect sensitive internal moving parts from contamination of dirt and foreign matter during service disassembly and reassembly.
2. Keep good records of service activity and include the pump in a preventive maintenance program.
3. Before disassembling, empty captured material in the outlet manifold by turning the pump upside down to drain material from the pump.

Troubleshooting

Possible Cause	Corrective Action
Product discharged from exhaust outlet.	Check for diaphragm rupture.
	Check tightness of diaphragm.
Air bubbles in product discharge.	Check suction plumbing connections.
	Check O-rings between intake manifold and fluid caps.
	Check tightness of the diaphragm nut.
Low output volume, erratic flow, or no flow.	Check air supply.
	Check for plugged outlet hose.
	Check for kinked (restrictive) or collapsed inlet material hose.
	Check for leakage in the connection. Connections must be air tight.
	Inspect the pump for solid objects lodged in the diaphragm chamber or the seat area.

Parts Diagram

1. MAIN PARTS DIAGRAM

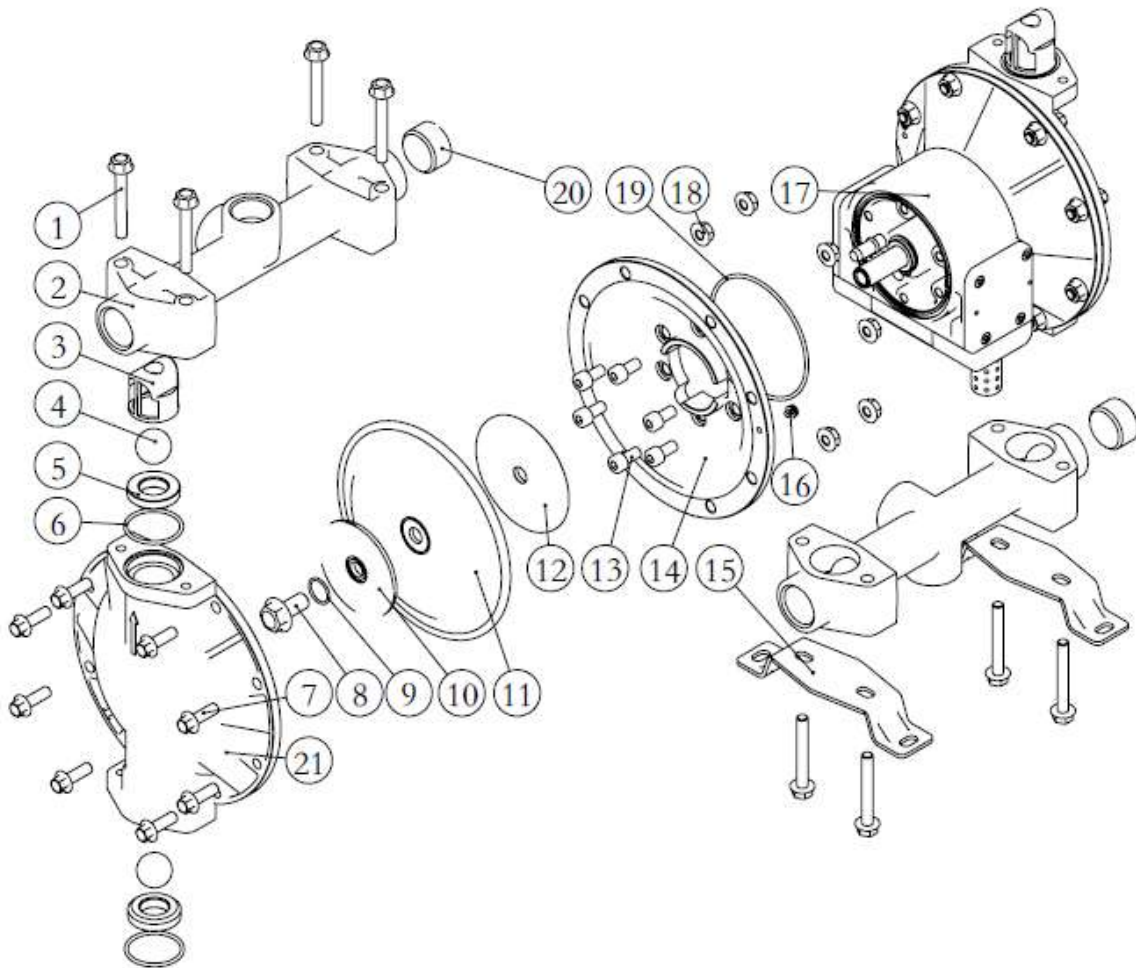

2. AIR MOTOR SECTION PARTS DIAGRAM:

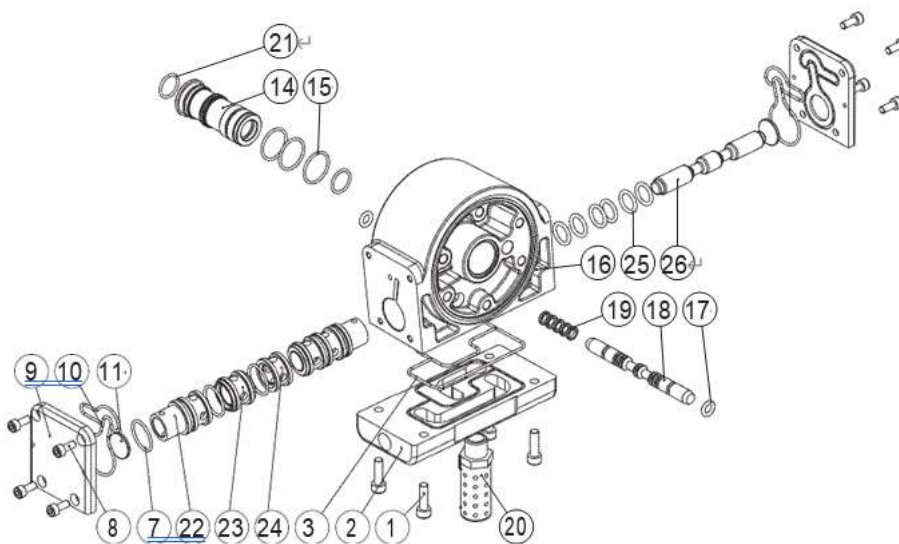

Parts List

1. MAIN PARTS LIST:

Part Number	Description	Qty.	Part Number	Description	Qty.
1	Hex Bolt M8*65	8	11	Diaphragm	2
2	Discharge Manifold	2	12	Air Chamber Plate	2
3	Valve Cover	2	13	Screw (M8 *16)	12
4	Valve Ball	4	14	Air Chamber	2
5	Valve Seat	4	15	Bracket	2
6	O-ring (1.49" * 0.1")	4	16	M4 * 6 Screw	1
7	Hex Bolt M8 * 25	16	17	Air Motor Assembly	1
8	Hex Bolt M12*25	2	18	Nut	16
9	O-ring (0.68" * 0.07")	2	19	O-ring (3.74" *0.1")	2
10	Liquid Chamber Plate	2	20	Plug	2
			21	Pump Cover	2

2. AIR MOTOR SECTION PARTS LIST:

Part	Description	Q'ty	Part	Description	Q'ty
1	Hex-bolt M6X20	4	*17	O-ring 7.1X2.65	2
2	Press board	1	18	Pilot Valve	1
3	Seal for press board	1	*19	O-ring 6.86X1.78	5
*7	O-ring 13.94x2.62	6	20	Muffler 3/8"	1
8	Hex bolt M5X12	8	*21	O-ring 15.60X1.78	2
9	Gasket	2	22	Spacer	2
*10	Seal for gasket	2	23	Spacer	2
*11	Washer	2	24	Spacer	1
14	Sleeve	1	25	O-ring 13.94X2.62	6
*15	O-ring 20.35X1.78	3	26	Major Valve	1
16	Retaining Ring 25	1			

Note: The Part No. with "*"are the wearing parts.

Replacement Parts

- For replacement parts and technical questions, please call Customer Service at **1-800-222-5381**.
- Not all product components are available for replacement. The illustrations provided are a convenient reference to the location and position of parts in the assembly sequence.
- When ordering parts, the following information will be required: item description, item model number, item serial number/item lot date code, and the replacement part reference number.
- The distributor reserves the rights to make design changes and improvements to product lines and manuals without notice.

Limited Warranty

Northern Tool and Equipment Company, Inc. ("We" or "Us") warrants to the original purchaser only ("You" or "Your") that the Roughneck product purchased will be free from material defects in both materials and workmanship, normal wear and tear excepted, for a period of **one year** from date of purchase. The foregoing warranty is valid only if the installation and use of the product is strictly in accordance with product instructions. There are no other warranties, express or implied, including the warranty of merchantability or fitness for a particular purpose. If the product does not comply with this limited warranty, Your sole and exclusive remedy is that We will, at our sole option and within a commercially reasonable time, either replace the product or product component without charge to You or refund the purchase price (less shipping). This limited warranty is not transferable.

Limitations on the Warranty

This limited warranty does not cover: (a) normal wear and tear; (b) damage through abuse, neglect, misuse, or as a result of any accident or in any other manner; (c) damage from misapplication, overloading, or improper installation; (d) improper maintenance and repair; and (e) product alteration in any manner by anyone other than Us, with the sole exception of alterations made pursuant to product instructions and in a workmanlike manner.

Obligations of Purchaser

You must retain Your product purchase receipt to verify date of purchase and that You are the original purchaser. To make a warranty claim, contact Us at 1-800-222-5381, identify the product by make and model number, and follow the claim instructions that will be provided. The product and the purchase receipt must be provided to Us in order to process Your warranty claim. Any returned product that is replaced or refunded by Us becomes our property. You will be responsible for return shipping costs or costs related to Your return visit to a retail store.

Remedy Limits

Product replacement or a refund of the purchase price is Your sole remedy under this limited warranty or any other warranty related to the product. We shall not be liable for: service or labor charges or damage to Your property incurred in removing or replacing the product; any damages, including, without limitation, damages to tangible personal property or personal injury, related to Your improper use, installation, or maintenance of the product or product component; or any indirect, incidental or consequential damages of any kind for any reason.

Assumption of Risk

You acknowledge and agree that any use of the product for any purpose other than the specified use(s) stated in the product instructions is at Your own risk.

Governing Law

This limited warranty gives You specific legal rights, and You also may have other rights which vary from state to state. Some states do not allow limitations or exclusions on implied warranties or incidental or consequential damages, so the above limitations may not apply to You. This limited warranty is governed by the laws of the State of Minnesota, without regard to rules pertaining to conflicts of law. The state courts located in Dakota County, Minnesota shall have exclusive jurisdiction for any disputes relating to this warranty.



Distributed by:

Northern Tool & Equipment Company, Inc.

Burnsville, Minnesota 55306

www.northerntool.com

Made in China