

PERFORMANCE CURVES

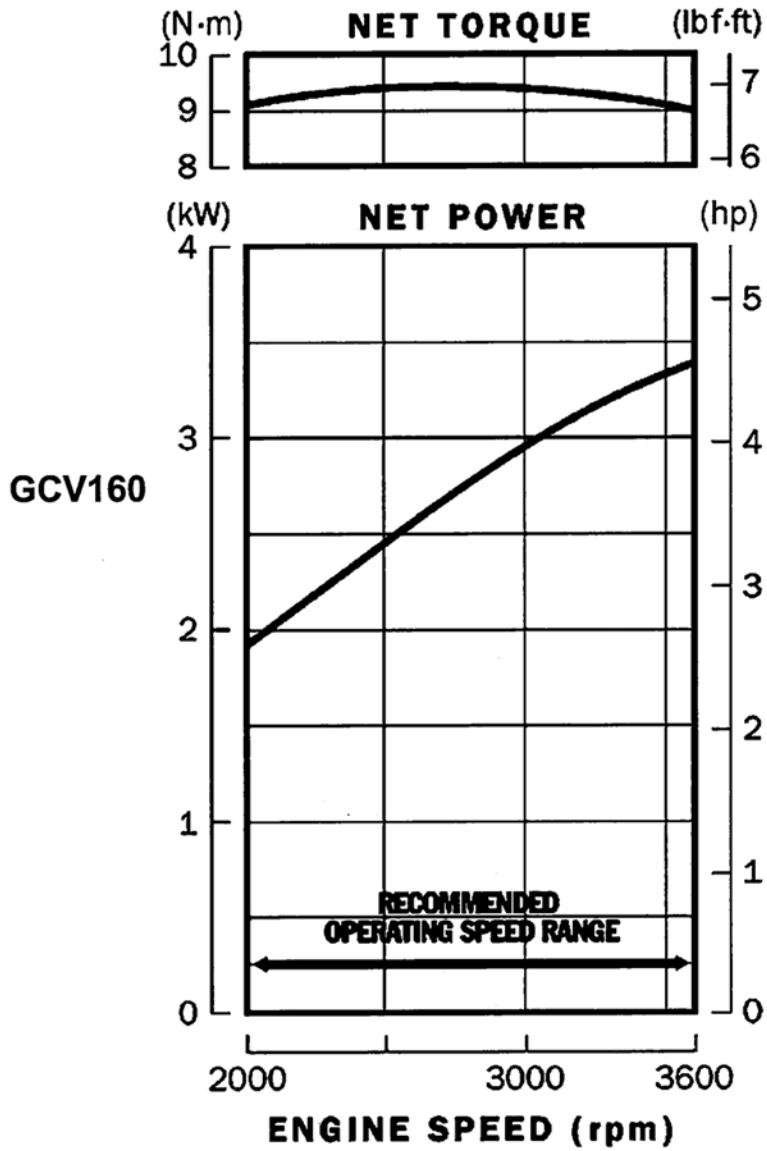

DIMENSIONAL DRAWINGS

Unit: mm (in)

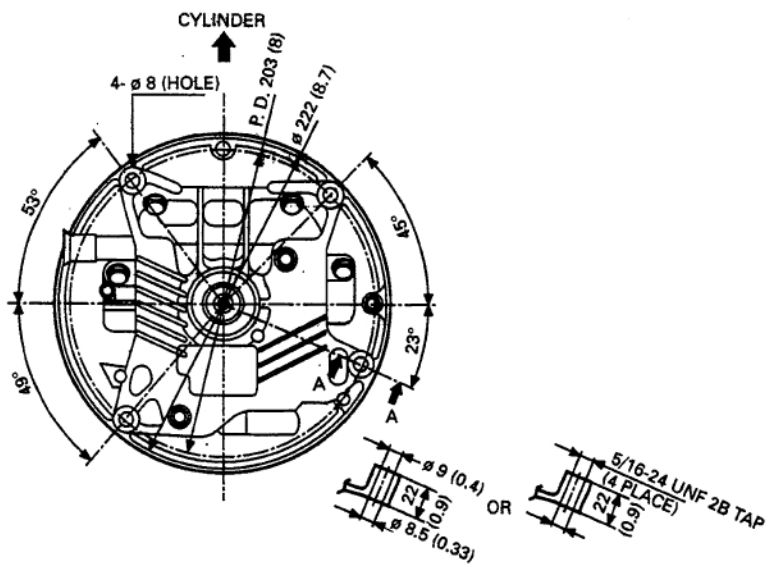
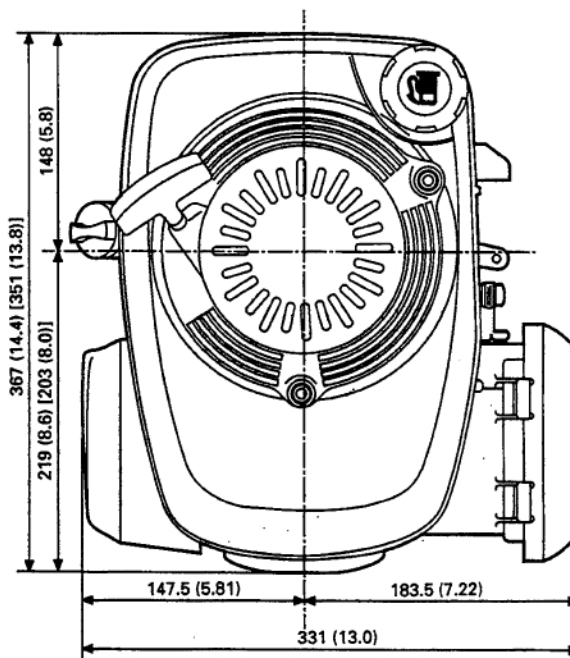
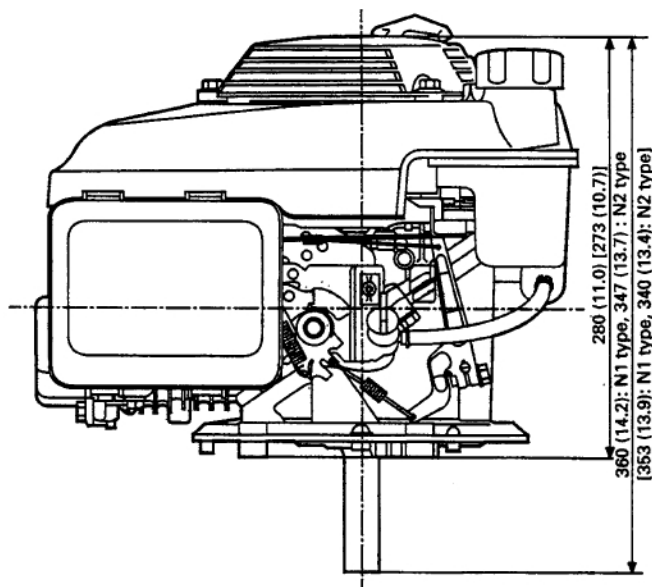

SECTION A-A

**GCV160LA TYPE
(SEPARATE FUEL TANK/EVAPORATIVE CANISTER GAS CAP)**

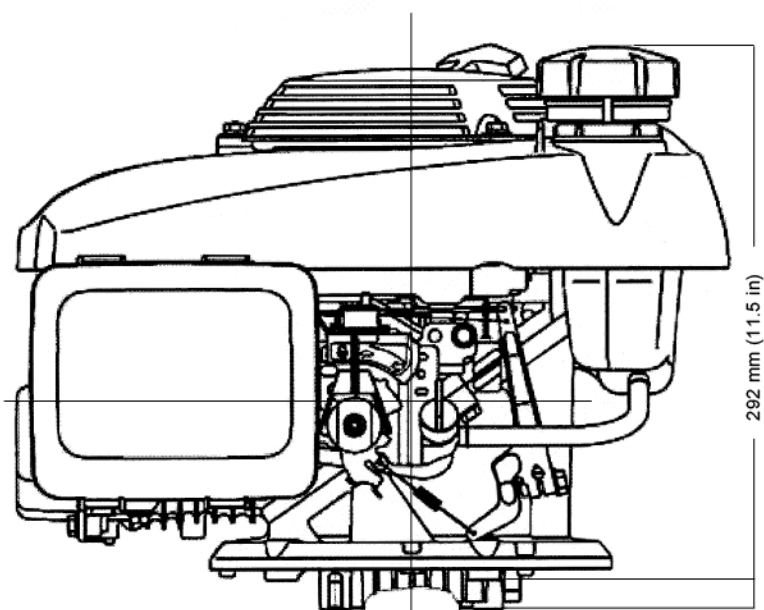
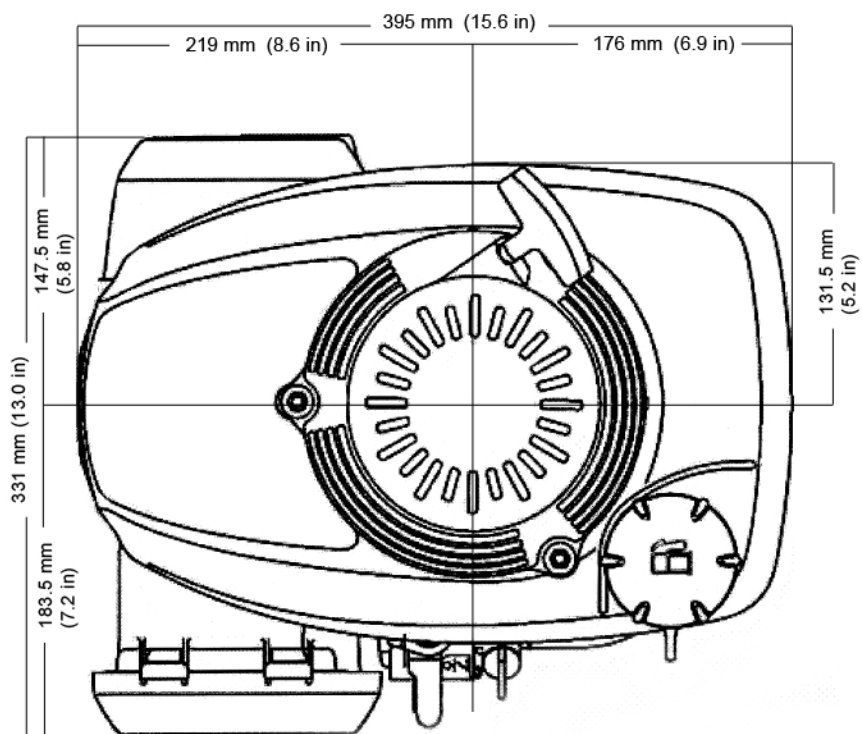

16 mm
(0.6 in)

GCV160

ELECTRIC START TYPES GCV160

Units: mm (in)

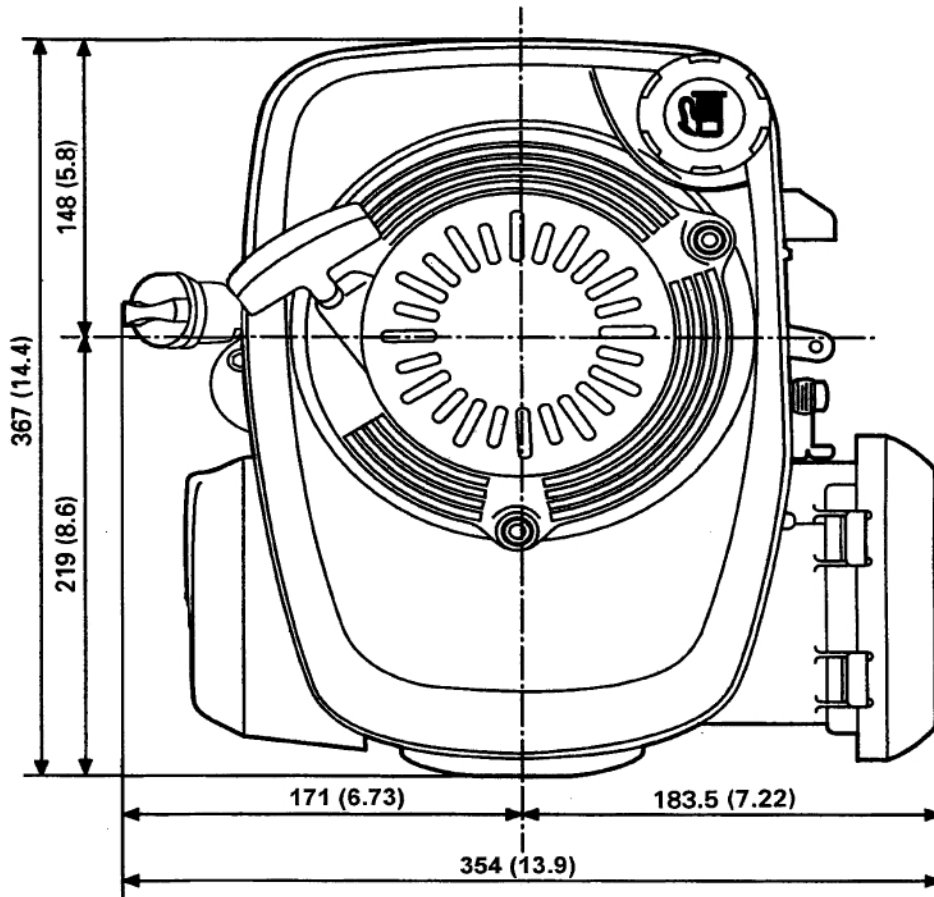

PTO DIMENSIONAL DRAWINGS

S3A-TYPE

Unit: mm (in)

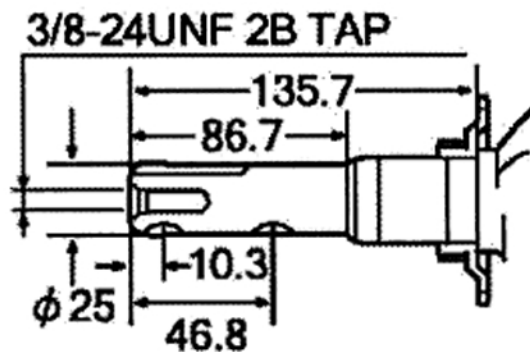

N1 type

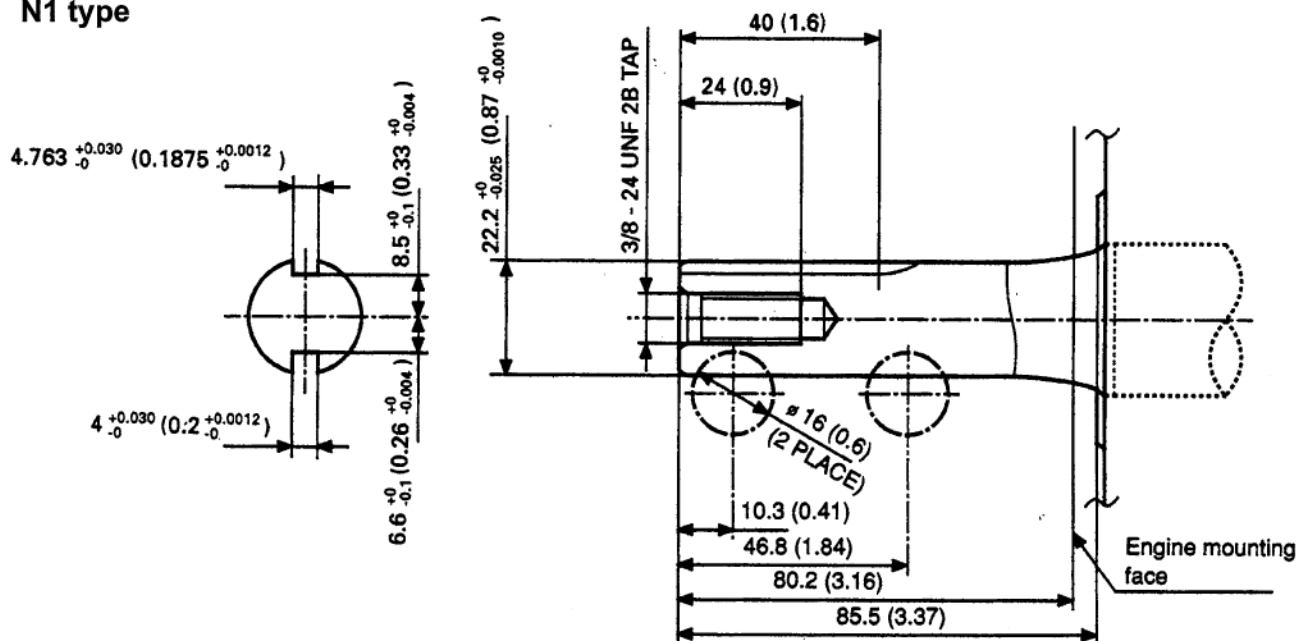

N5 type

