

PERFORMANCE CURVE

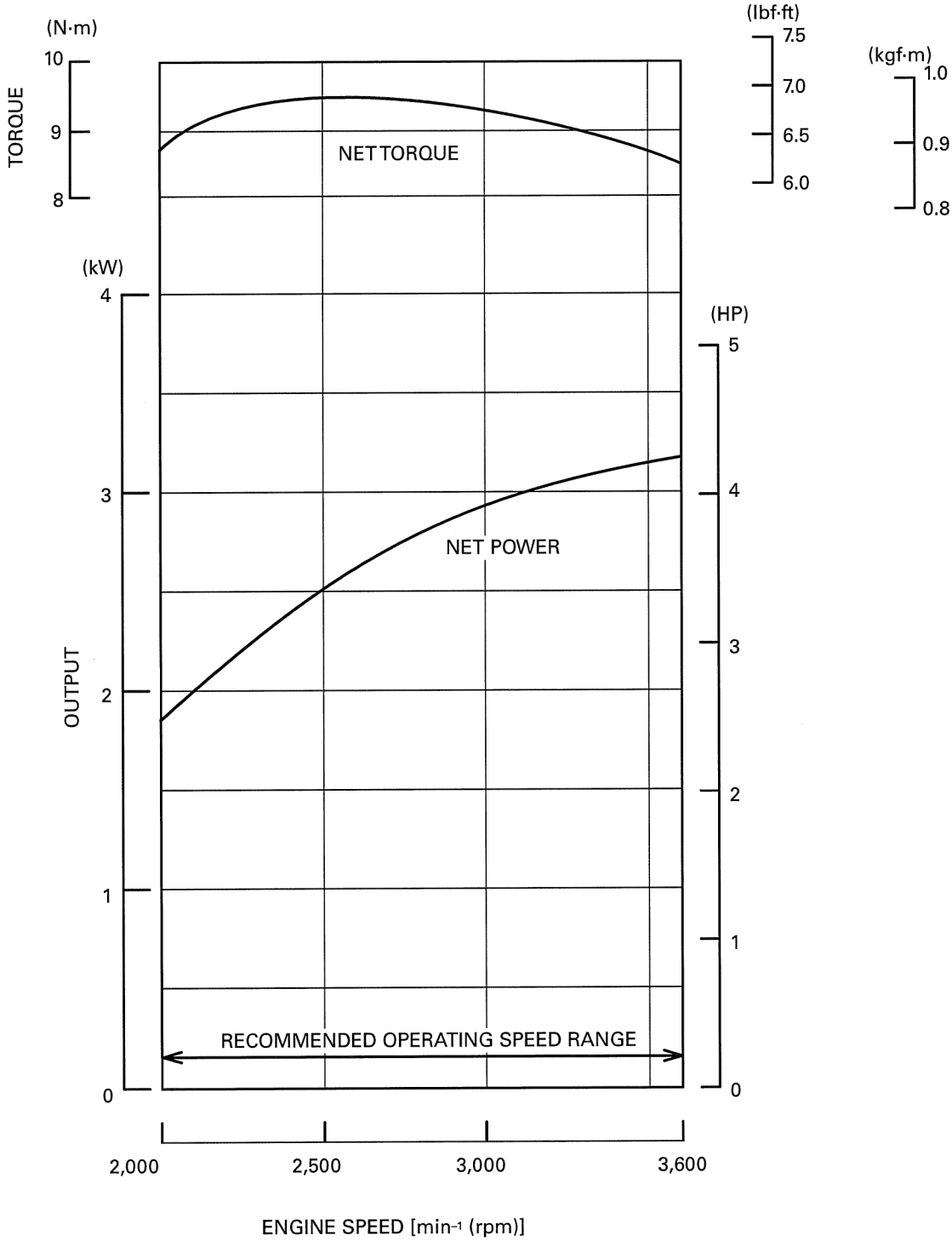

DIMENSIONAL DRAWINGS

GXV160UH2 model
*1: N5 type only
*2: N1 type only

Unit: mm (in)

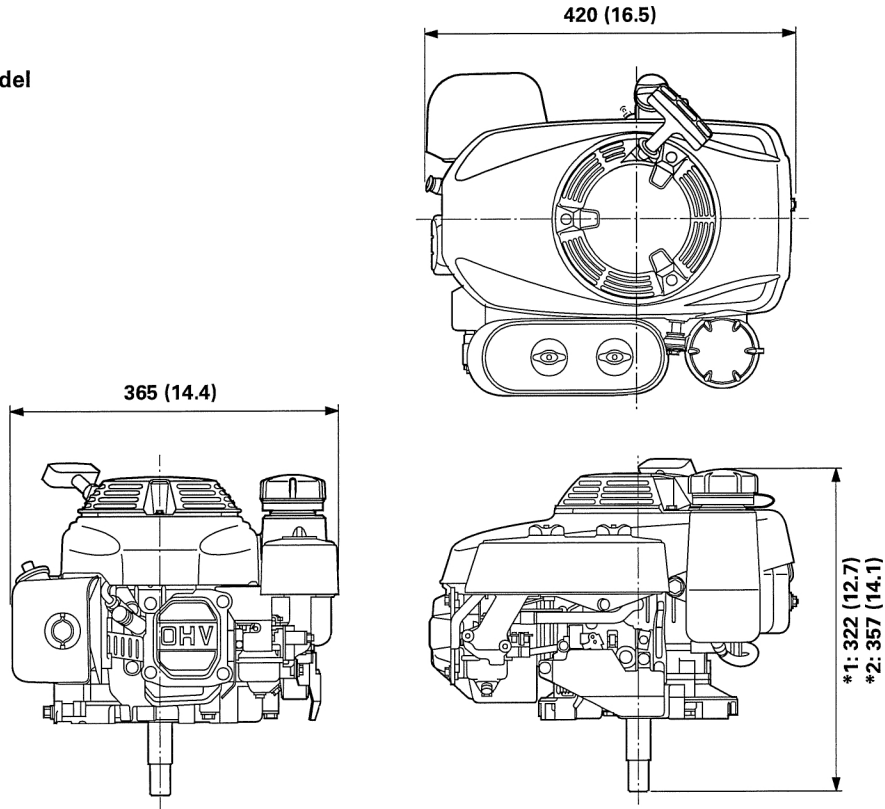

•Without drive shaft type

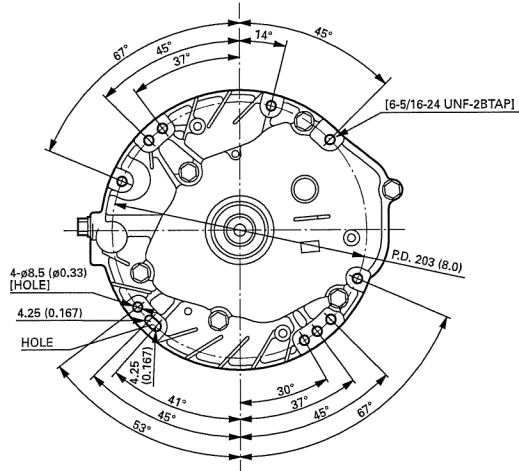

GXV160UH

PTO DIMENSIONAL DRAWINGS

N5 shaft type

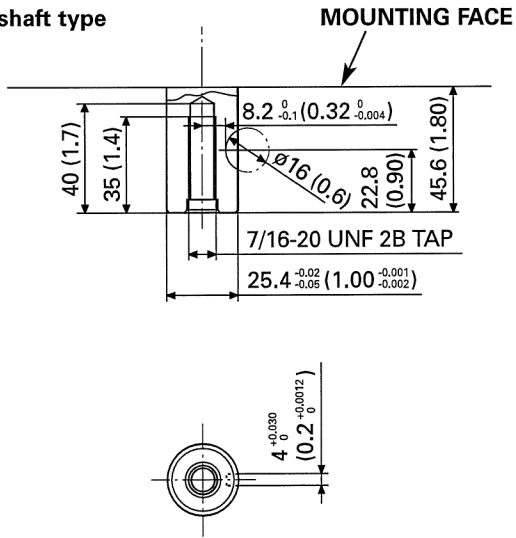

N1 shaft type

